

## Class-AB Speaker Amplifiers

## 1.9W+1.9W

## Stereo Speaker Amplifier



BD7836EFV

No.10077EAT07

**●Description**

BD7836EFV is a Class-AB stereo speaker amplifier, developed for note-book PC, desktop PC, portable devices and others. Class-AB amplifier has no EMI noise. Power package HTSSOP-B20 can realize high output power. Low circuit current at active mode reduce consumption of battery. Shutdown current is 0.1μA typically, and pop noise level when shutdown turns on and off is very small. This device is suitable for the application that often changes mode between “shutdown state” and “active state”.

**●Features**

- 1) High power 1.9W typ. (VDD=5V, RL=4Ω, THD+N=1%, stereo input)  
High power 1.2W typ. (VDD=5V, RL=8Ω, THD+N=1%, stereo input)
- 2) Gain selectable by the external control (6,10,15.6,21.6dB)
- 3) Pop noise suppression circuitry
- 4) Shutdown function (also Mute function) [I<sub>sd</sub>=0.1μA(typ.)]
- 5) Protection circuitry (Thermal shutdown, Under voltage lockout)
- 6) Power Package with thermal pad HTSSOP-B20

**●Applications**

Note-book PC, Desktop PC, etc.

**●Absolute maximum ratings (Ta=+25°C)**

| Parameter                               | Symbol | Ratings      | Unit |
|---|--------|--------------|------|
| Power Supply Voltage                    | VDDmax | 7.0          | V    |
| Power Dissipation                       | Pd     | 1 *1         | W    |
|   |        | 3.2 *2       | W    |
| Storage Temperature                     | Tstg   | -55 ~ +150   | °C   |
| Input Terminal Input Voltage Range *3   | Vin    | -0.3~VDD+0.3 | V    |
| Control Terminal Input Voltage Range *4 | Vctl   | -0.3~VDD+0.3 | V    |

\*1 70mm×70mm×1.6mm FR4 1-layer glass epoxy board(Copper on top layer 0%)

Derating in done at 8mW/°C for operating above Ta=25°C. There are thermal via on the board.

\*2 70mm×70mm×1.6mm FR4 4-layer glass epoxy board (Copper on bottom 2 and 3 layer 100%)

Derating in done at 25.6mW/°C for operating above Ta=25°C. There are thermal via on the board.

\*3 Input Terminal (LIN+, LIN-, RIN+, RIN-)

\*4 Control Terminal ( SHUTDOWN , GAIN0, GAIN1)

**●Operating conditions**

| Parameter            | Symbol | Range       | Unit |
|----------------------|--------|-------------|------|
| Power Supply Voltage | VDD    | +4.5 ~ +5.5 | V    |
| Temperature          | Topr   | -40 ~ +85   | °C   |

\* These products aren't designed for protection against radioactive rays.

●Electric characteristic (Unless otherwise specified, Ta=+25°C, VDD=+5.0V, R<sub>L</sub>=8Ω, AC stereo input)

| Parameter                                   | Symbol             | Limits          |      |      | Unit  | Condition   |
|---|--------------------|-----------------|------|------|-------|---|
|   |                    | Min.            | Typ. | Max. |       |   |
| Circuit current (Active)                    | I <sub>cc</sub>    | —               | 5    | 10   | mA    | IC active, No load<br>SHUTDOWN =Hi                                    |
| Circuit current (Shutdown)                  | I <sub>sd</sub>    | —               | 0.1  | 2.0  | μA    | IC Shutdown<br>SHUTDOWN =Lo   |
| <Speaker amplifier>                         |                    |                 |      |      |       |   |
| Output power 1                              | P <sub>O1</sub>    | 0.7             | 1.2  | —    | W     | RL=8Ω, BTL, f=1kHz, THD+N=1% *1                                       |
| Output power 2                              | P <sub>O2</sub>    | —               | 1.9  | —    | W     | RL=4Ω, BTL, f=1kHz, THD+N=1% *1                                       |
| Gain  | G <sub>V</sub>     | 5.5             | 6.0  | 6.5  | dB    | BTL, GAIN0=GAIN1=L  |
|   |                    | 9.5             | 10   | 10.5 | dB    | BTL, GAIN0=L, GAIN1=H   |
|   |                    | 14.6            | 15.6 | 16.5 | dB    | BTL, GAIN0=H, GAIN1=L   |
|   |                    | 20.6            | 21.6 | 22.6 | dB    | BTL, GAIN0=GAIN1=H  |
| Input resistance                            | R <sub>IN</sub>    | 63              | 90   | 117  | kΩ    | GAIN0=GAIN1=L   |
|   |                    | 49              | 70   | 91   | kΩ    | GAIN0=L, GAIN1=H  |
|   |                    | 31              | 45   | 59   | kΩ    | GAIN0=H, GAIN1=L  |
|   |                    | 17              | 25   | 33   | kΩ    | GAIN0=GAIN1=H   |
| Supply ripple rejection ratio               | PSRR               | 62              | 68   | —    | dB    | V <sub>ripple</sub> =0.2Vp-p, C <sub>BYP</sub> =0.47μF<br>f=1kHz, BTL |
| Output noise                                | V <sub>noise</sub> | —               | 16   | 80   | μVrms | BTL, f=1kHz, 20-20kHz   |
| S/N   | S <sub>N</sub>     | —               | 105  | —    | dB    | BTL, P <sub>o</sub> =1W, BTL, f=1kHz, 20-20kHz                        |
| Output DC offset voltage                    | ΔV <sub>o</sub>    | —               | 0    | ±25  | mV    |   |
| <Control terminal ( SHUTDOWN ,GAIN0,GAIN1)> |                    |                 |      |      |       |   |
| Control terminal                            | Hi level           | V <sub>IH</sub> | 2.0  | —    | VDD   | V   |
| Input voltage                               | Lo level           | V <sub>IL</sub> | 0    | —    | 0.8   | V   |

\*1: B.W.=400~30kHz. BTL : The voltage between 4pin and 8pin, 14pin and 18pin.

●Control terminal's settings

| SHUTDOWN | IC condition |
|----------|--------------|
| Hi       | Active       |
| Lo       | Shutdown     |

| GAIN0 | GAIN1 | Gain   | Input resistance |
|-------|-------|--------|------------------|
| Lo    | Lo    | 6dB    | 90kΩ (TYP.)      |
| Lo    | Hi    | 10dB   | 70kΩ (TYP.)      |
| Hi    | Lo    | 15.6dB | 45kΩ (TYP.)      |
| Hi    | Hi    | 21.6dB | 25kΩ (TYP.)      |

●Package outlines

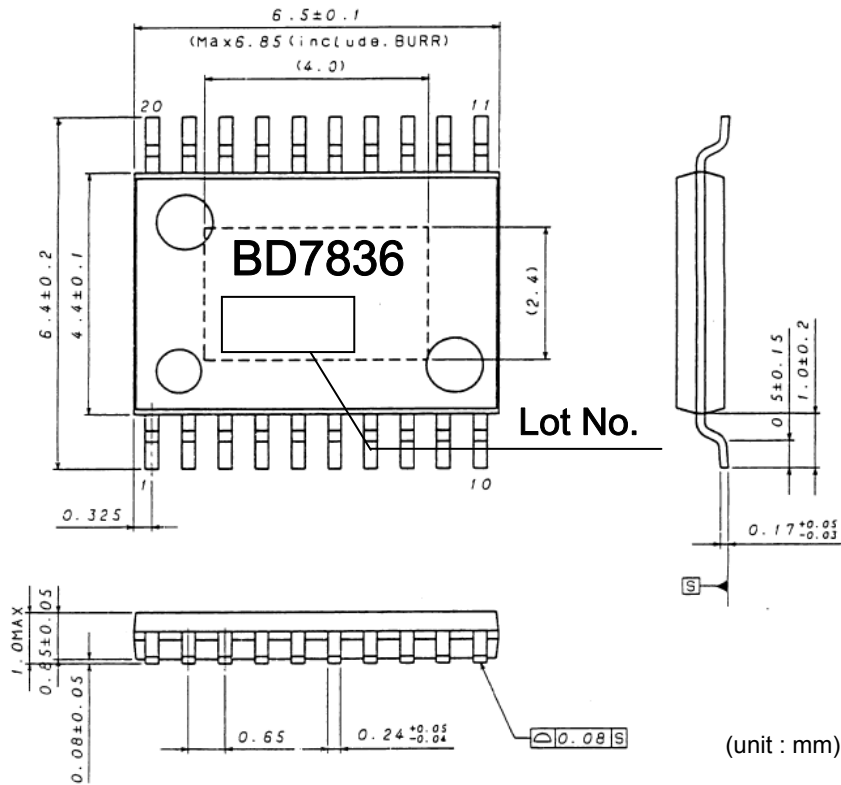

Fig.1 HTSSOP-B20

●Block diagram

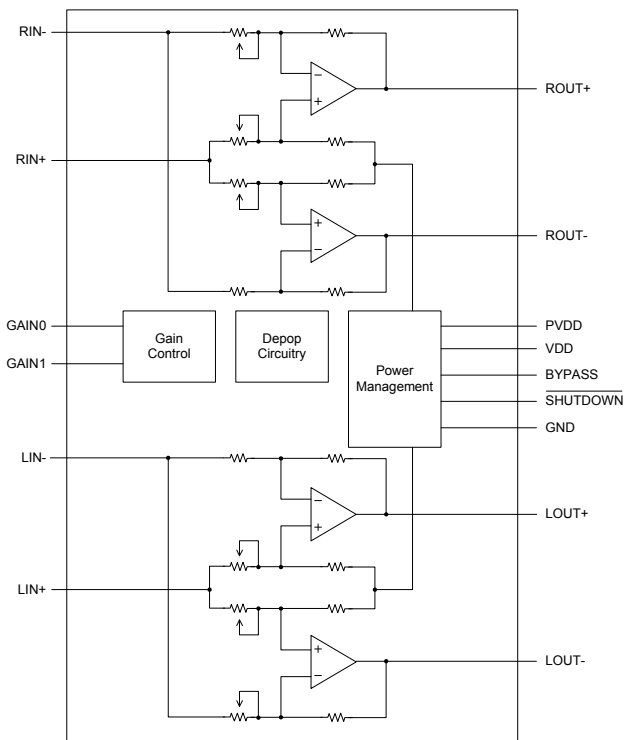

Fig.2

●Pin assignment table

| Pin No. | Terminal name   | Function   |
|---------|-----------------|--|
| 1       | GND             | Ground   |
| 2       | GAIN0           | Bit 0 of gain select   |
| 3       | GAIN1           | Bit 1 of gain select   |
| 4       | LOUT+           | Left channel positive output                                 |
| 5       | LIN-            | Left channel negative differential input                     |
| 6       | PVDD            | Supply voltage terminal                                      |
| 7       | RIN+            | Right channel negative differential input                    |
| 8       | LOUT-           | Left channel negative output                                 |
| 9       | LIN+            | Left channel positive differential input                     |
| 10      | BYPASS          | Tap to voltage divider for internal midsupply bias generator |
| 11      | GND             | Ground   |
| 12      | NC              | No connection  |
| 13      | GND             | Ground   |
| 14      | ROUT-           | Right channel negative output                                |
| 15      | PVDD            | Supply voltage terminal                                      |
| 16      | VDD             | Supply voltage terminal                                      |
| 17      | RIN-            | Right channel negative differential input                    |
| 18      | ROUT+           | Right channel positive output                                |
| 19      | <u>SHUTDOWN</u> | Places IC in shutdown mode when held low                     |
| 20      | GND             | Ground   |

● Measurement circuit diagram

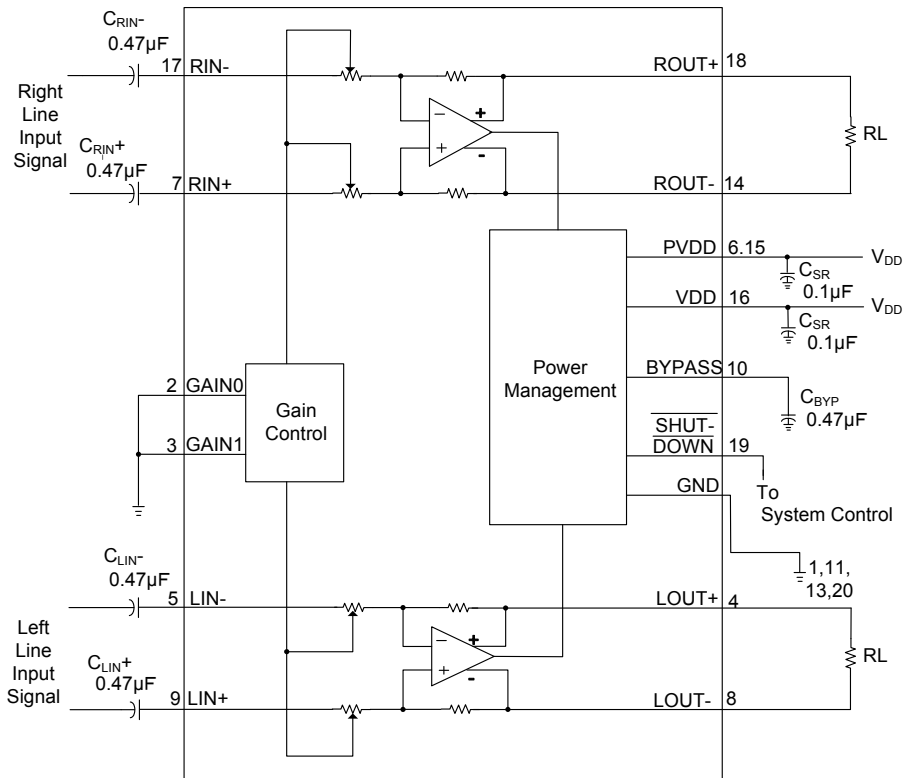

Fig.3

●Application circuit example

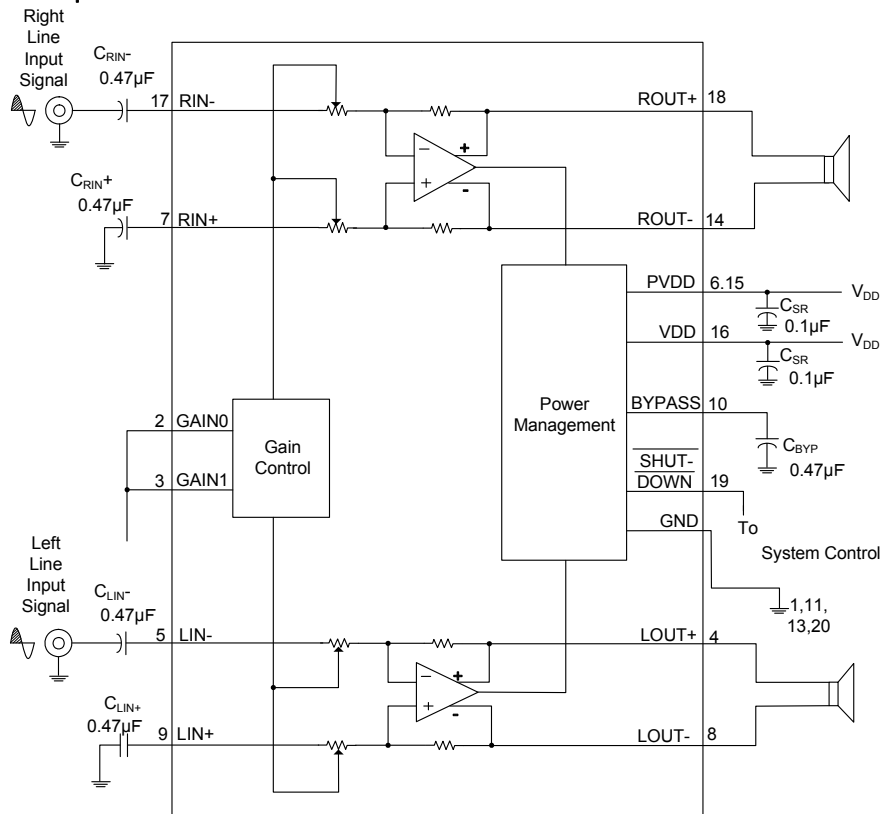

Fig.4 Single Ended inputs

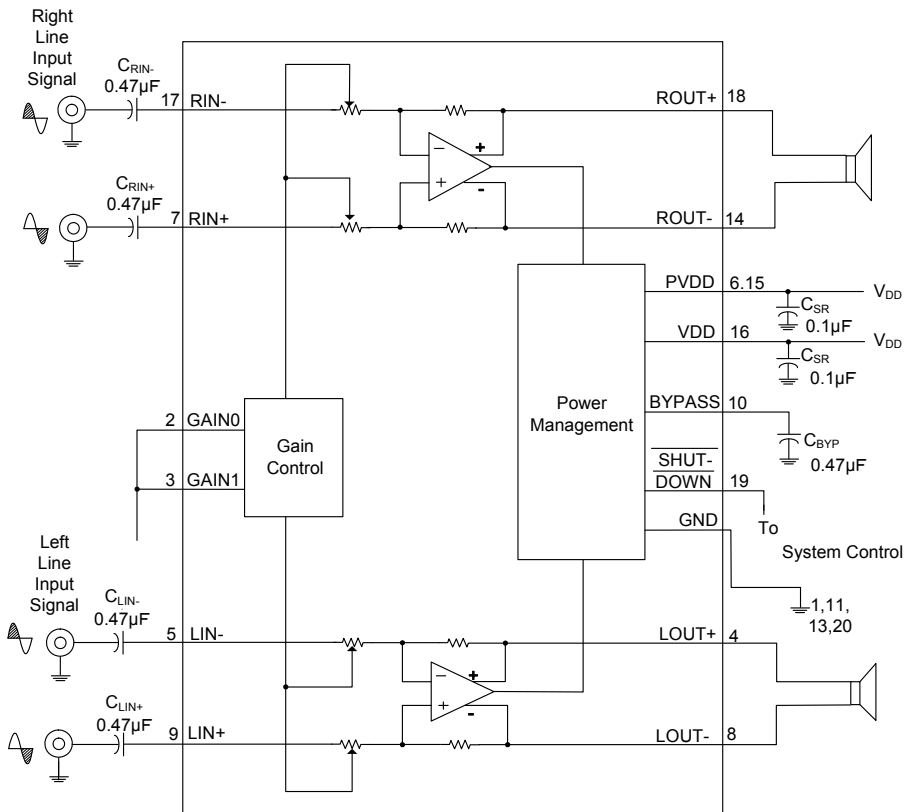
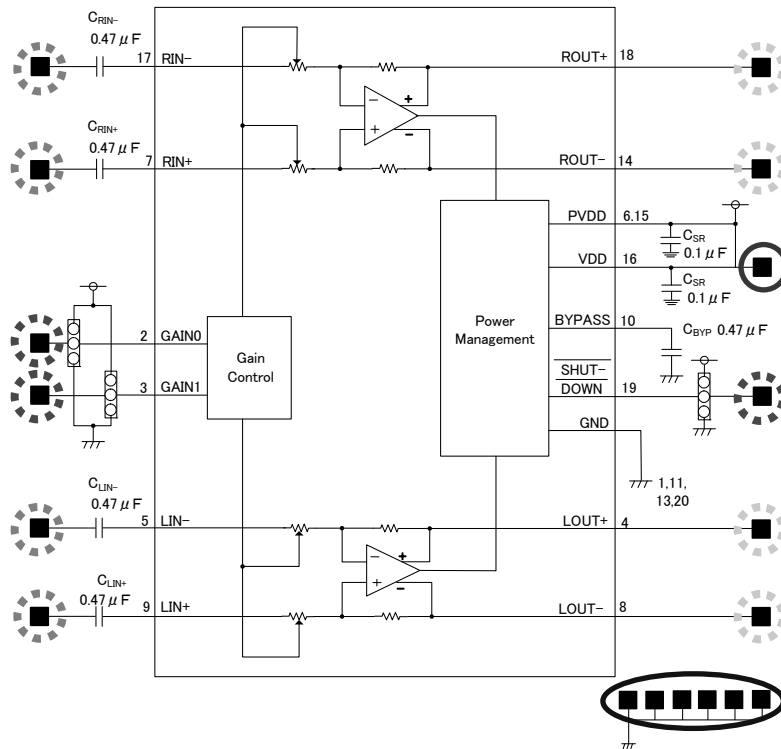

Fig.5 Differential inputs

● Evaluation board circuit diagram



Please connect speaker.

Please connect to GND.

Please connect to Power Supply (VDD=+4.5~5.5V) line.

Use these solder jumper for connecting the control terminal to GND.

Use these solder jumper for connecting the control terminal to VDD.

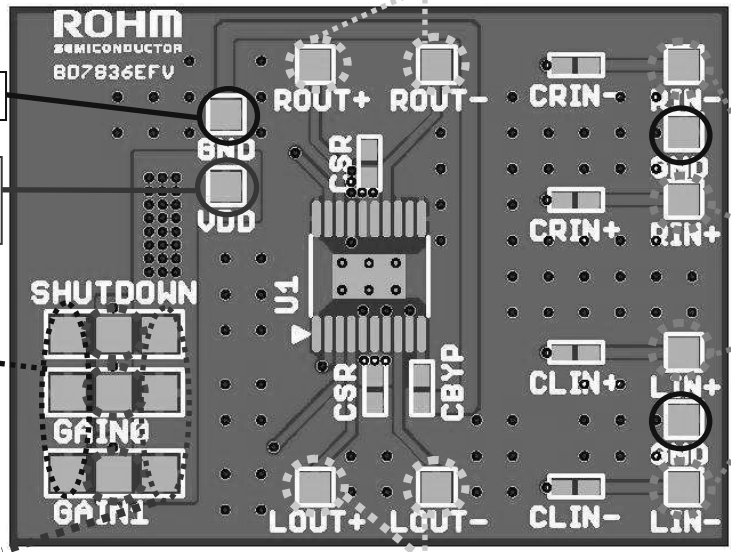

Please connect ito input signal line.

Please connect speaker.

Fig. 6

● Evaluation board parts list

| Number | Part name        | Type, Value                                      | SMD size       | Manufacturer/ Part number    |
|--------|------------------|--|----------------|------------------------------|
| 4      | CLIN+/-, CRIN+/- | Capacitor, 0.47μF                                | 1608           | Murata<br>GRM188R71C474KA01D |
| 2      | CSR              | Capacitor, 0.1μF                                 | 1608           | Murata<br>GRM188R71C104KA01D |
| 1      | CBYP             | Capacitor, 0.47μF                                | 1608           | Murata<br>GRM188R71C474KA01D |
| 1      | U1               | IC, BD7836EFV, Class-AB stereo speaker Amplifier | PKG:HTSSOP-B20 | ROHM<br>BD7836EFV-E2         |
| 1      | PCB1             | Printed-circuit board BD7836EFV                  | —              | —                            |

## ●Description of external parts

### ①Input coupling capacitors $C_i$ (CLIN+/-,CRIN+/-)

It sets cutoff frequency  $f_c$  by the following formula by input coupling capacitors  $C_i$ (CLIN+/-,CRIN+/-) and input impedance  $Z_i$ .

$$f_c = \frac{1}{2\pi \times Z_i \times C_i} [\text{Hz}]$$

It makes an input coupling capacitors of evaluation board 0.47 $\mu$ F on evaluation board..  
Input impedance  $Z_i$  and cutoff frequency  $f_c$  in each gain settings are given in Table1.

Table1. The relations in the gain settings and cutoff frequency  $f_c$ .

| GAIN0 | GAIN1 | Gain [dB] | Ri $\Omega$ | Zi [ $\Omega$ ] | $f_c$ [Hz] |
|-------|-------|-----------|-------------|-----------------|------------|
| Lo    | Lo    | 6         | 90k         | 45k             | 7.5        |
| Lo    | Hi    | 12        | 70k         | 35k             | 9.7        |
| Hi    | Lo    | 18        | 45k         | 22.5k           | 15         |
| Hi    | Hi    | 24        | 25k         | 12.5k           | 27         |

### ②The power decoupling capacitors ( $C_{SR}$ )

It makes a power decoupling capacitors 0.1 $\mu$ F. Because power decoupling capacitors influences total harmonic distortion (THD) and some audio characteristics, please place a good low equivalent-series-resistance (ESR) capacitors as close as possible to IC.

### ③BYPASS capacitor ( $C_{BYP}$ )

Because BYPASS capacitor influences THD, PSRR and some audio characteristics, please place good low equivalent-series-resistance (ESR) capacitor as close as possible to IC.

The value of BYPASS capacitor determines the turn on time and turn off time.

Refer to the following section of "Turn ON and Turn OFF".

It makes BYPASS capacitor of evaluation board 0.47 $\mu$ F.

### ④Control terminal

Each control terminal ( SHUTDOWN , GAIN0, GAIN1) don't have pull-down resistance internal circuit.

Connect to GND line or VDD line or input Low or high level voltage to terminals in order to avoid the terminals made high Impedance.

Using IC under the control terminal let high impedance, operation fault may occur.

●Evaluation board PCB layer

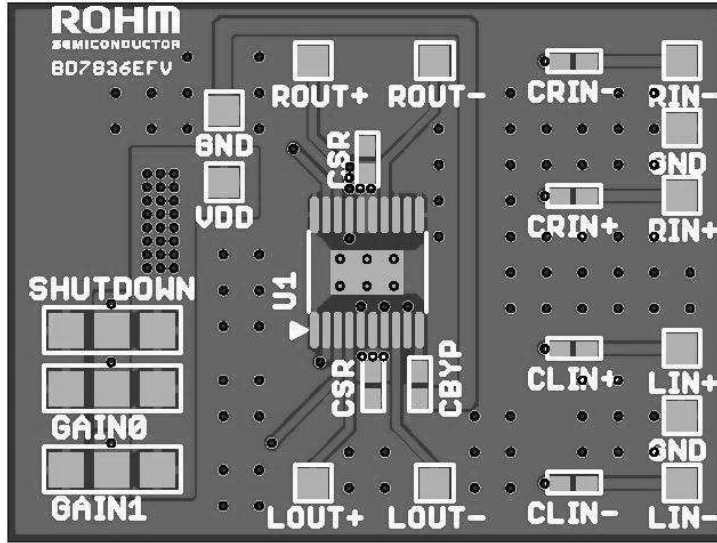

Fig.7 Top layer

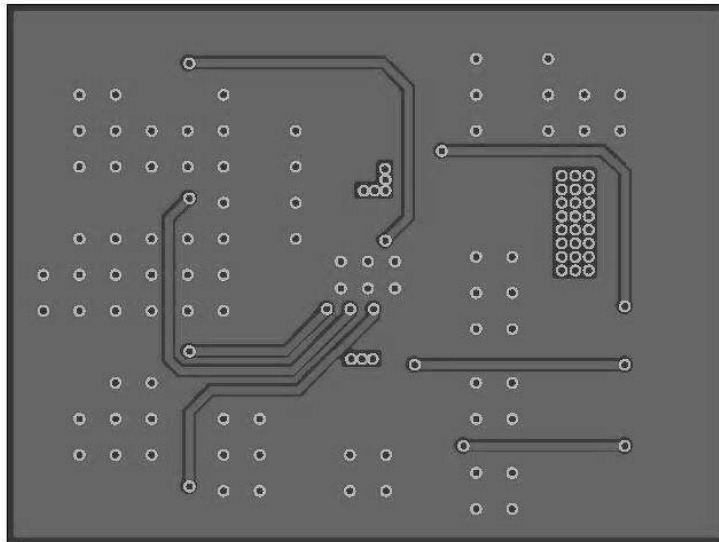

Fig.8 Bottom Layer



● Turn on and Turn off

This IC has the circuit that reduces pop noise at “turn on” and “turn off”.  
Reducing pop noise is realized in controlling to adjust the turn on and turn off time.

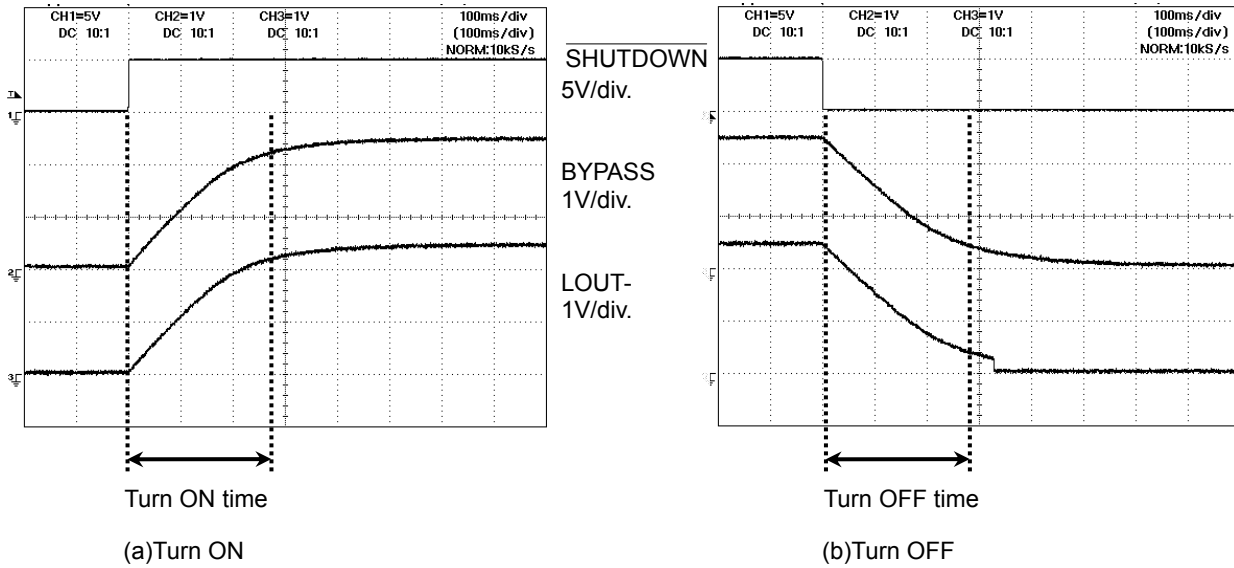

Fig. 9

The following table show the Turn ON time and Turn OFF time when It makes the Bypass capacitor 0.47uF.

| CBYP   | Turn ON | Turn OFF |
|--------|---------|----------|
| 0.47uF | 280ms   | 340ms    |

Turn ON time is defined as the time until Bypass terminal voltage reaches the 90% of VDD/2 after SHUTDOWN L→H.  
Turn OFF time is defined as the time until Bypass terminal voltage reaches the 10% of VDD/2 after SHUTDOWN H→L.

The values of above table are typical characteristics. These values will shift by 30% at some conditions.

● Input terminal

This IC can be inputted signal by differential inputs or single ended inputs.  
When using the single ended inputs, connect the terminal of not signal inputted line to AC GND with input coupling capacitors.  
Please make the value of all input capacitors same because of preventing pop noise.  
If they are not same value, for example, LOUT+=0.47μF, LOUT-=0.33μF, it caused pop noise increase and characteristics become worse.

●About the thermal design by the IC

Characteristics of an IC have a great deal to do with the temperature at which it is used, and exceeding absolute maximum ratings may degrade and destroy elements. Careful consideration must be given to the heat of the IC from the two standpoints of immediate damage and long-term reliability of operation. Pay attention to points such as the following.

Since an maximum junction temperature ( $T_{jMAX}$ .)or operating temperature range ( $T_{opr}$ ) is shown in the absolute maximum ratings of the IC, to reference the value, find it using the Pd-Ta characteristic (temperature derating curve).

If an input signal is too great when there is insufficient radiation, TSD (thermal shutdown) may operate.

TSD, which operates at a chip temperature of approximately  $+180^{\circ}C$ , is canceled when this goes below approximately  $+100^{\circ}C$ .

Since TSD operates persistently with the purpose of preventing chip damage, be aware that long-term use in the vicinity that TSD affects decrease IC reliability.

Temperature Derating Curve

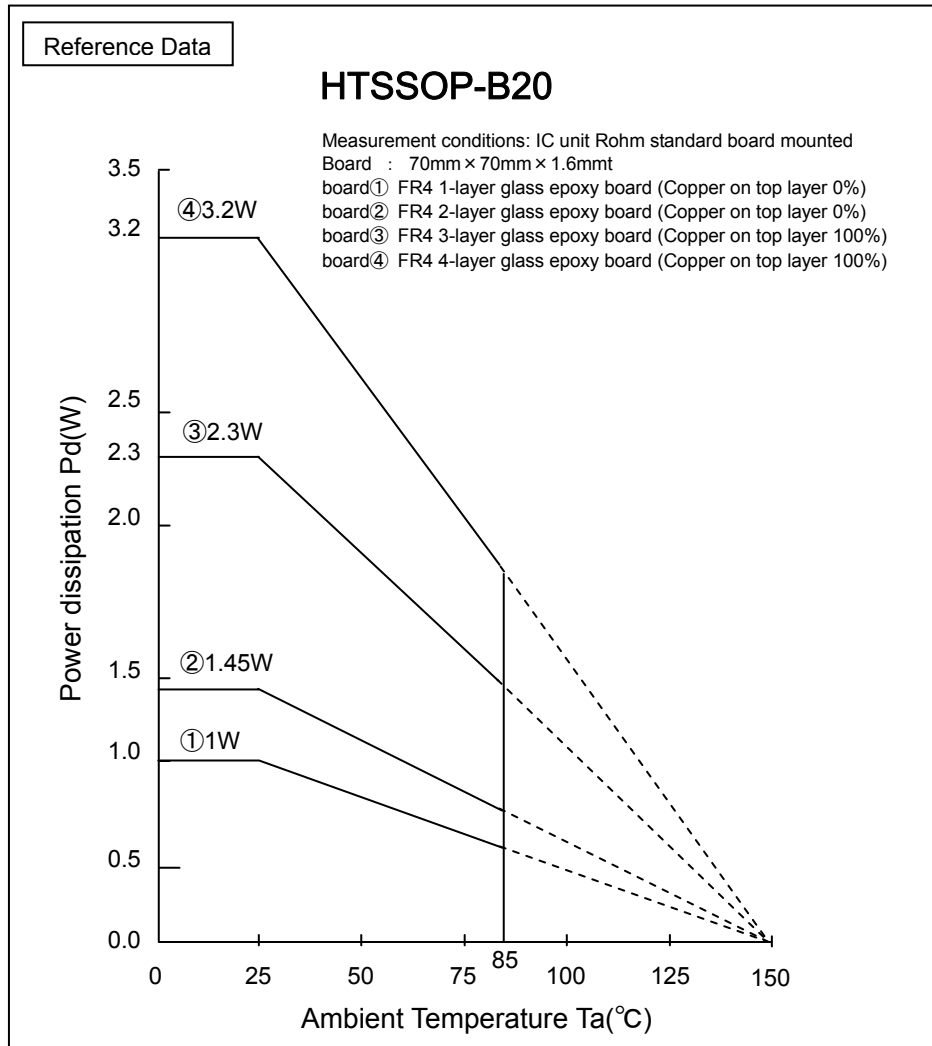

Note) Values are actual measurements and are not guaranteed.

Fig.10 Power dissipation vs. Ambient temperature

Power dissipation values vary according to the board on which the IC is mounted. The Power dissipation of this IC when mounted on a multilayer board designed to radiate is greater than the values in the graph above.

● Typical Characteristics

TABLE OF GRAPHS

| Items  | Parameter           | Figure number                  |
|--|---------------------|--------------------------------|
| Total harmonic distortion plus noise (THD+N) | vs. Frequency       | 11, 12, 17, 18                 |
|  | vs. Output power    | 13, 14, 15, 16, 19, 20, 21, 22 |
| Supply current (I <sub>cc</sub> )            | vs. Supply voltage  | 23                             |
| Shutdown current (I <sub>sd</sub> )          | vs. Supply voltage  | 24                             |
| Gain   | vs. Frequency       | 25                             |
| Crosstalk                                    | vs. Frequency       | 26                             |
| Supply ripple rejection ratio                | vs. Frequency       | 27                             |
| Shutdown attenuation                         | vs. Frequency       | 28                             |
| Power dissipation                            | vs. Output power    | 29                             |
| Efficiency                                   | vs. Output power    | 30                             |
| Output power                                 | vs. Load resistance | 31                             |

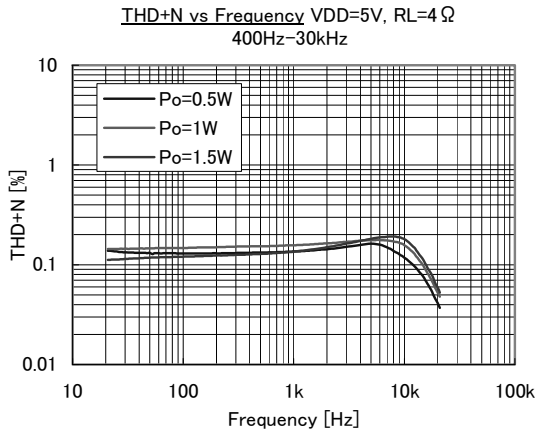

Fig.11

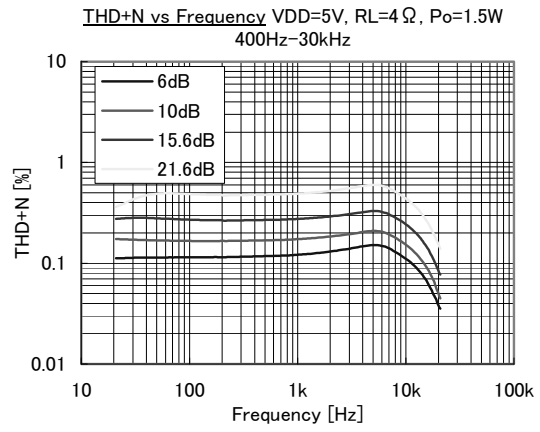

Fig.12

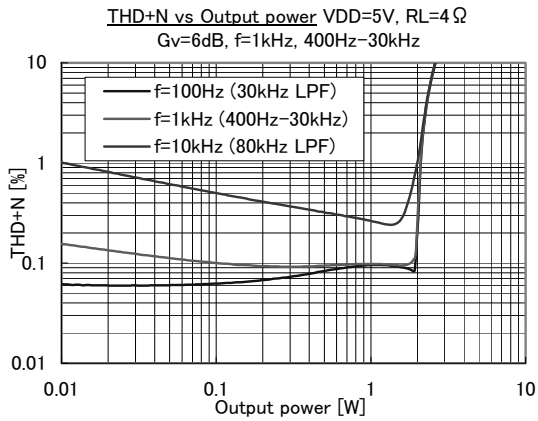

Fig.13

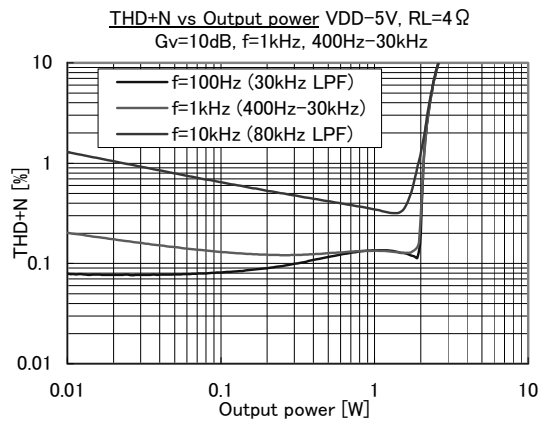

Fig.14

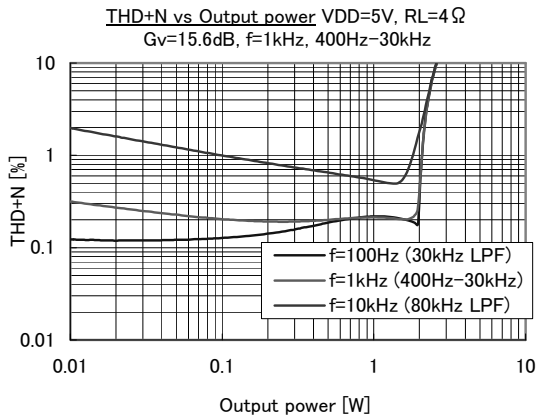

Fig.15

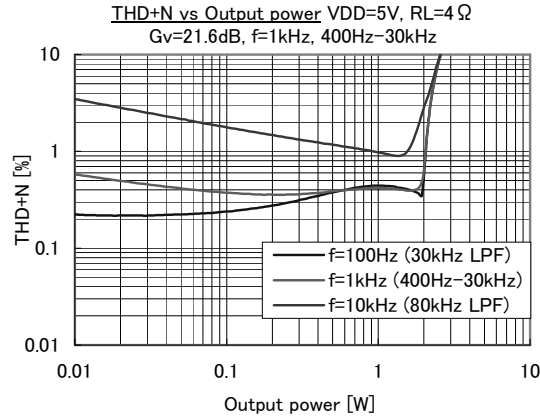

Fig.16

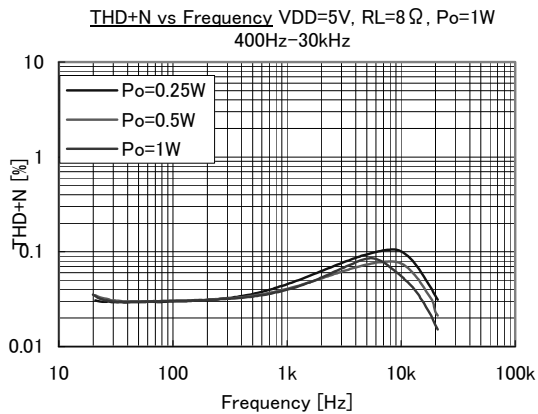

Fig.17

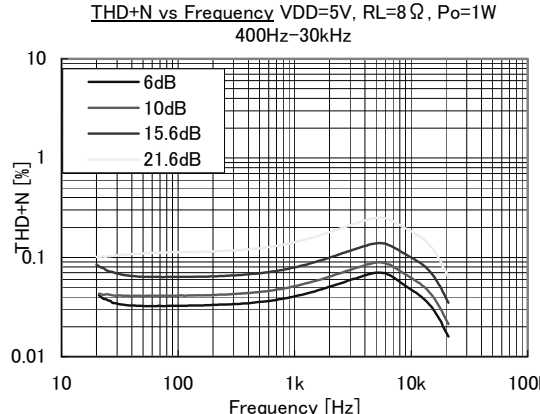

Fig.18

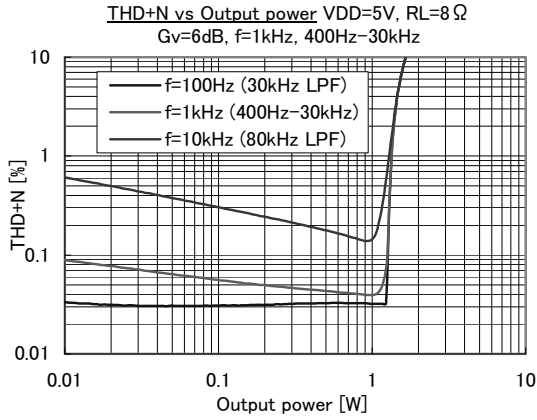

Fig.19

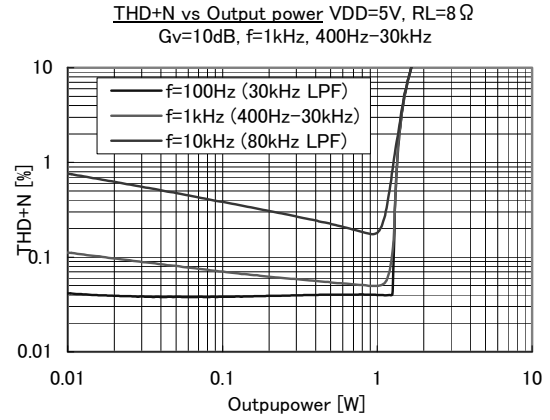

Fig.20

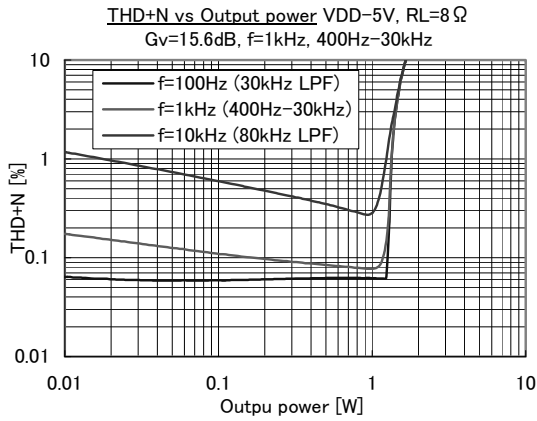

Fig.21

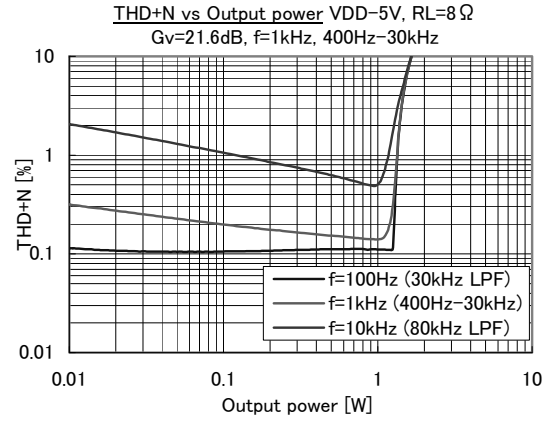

Fig.22

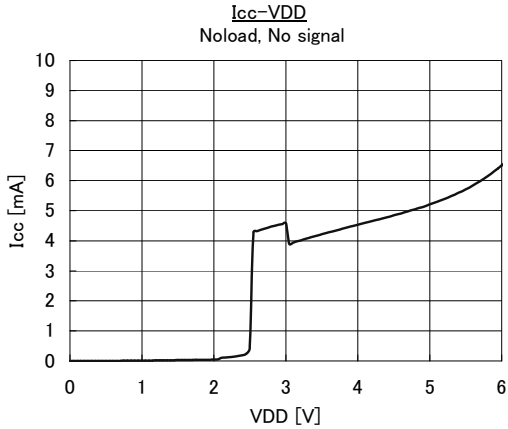

Fig.23

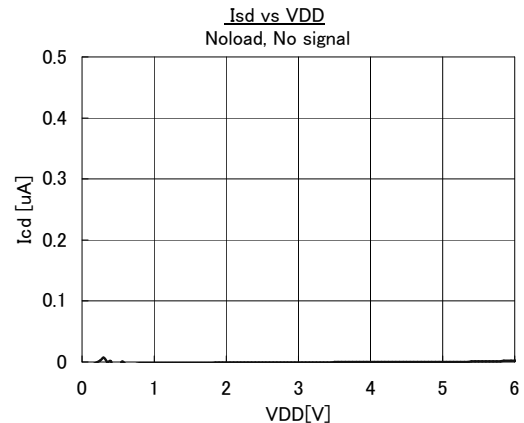

Fig.24

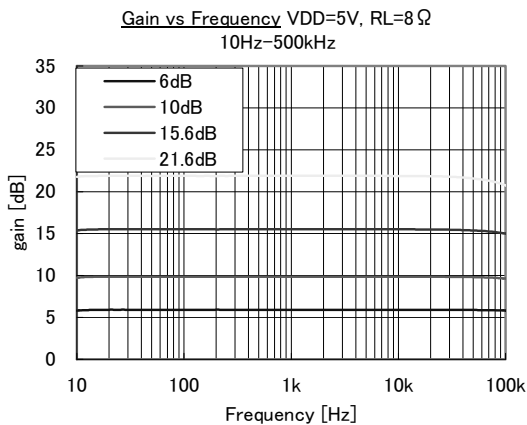

Fig.25

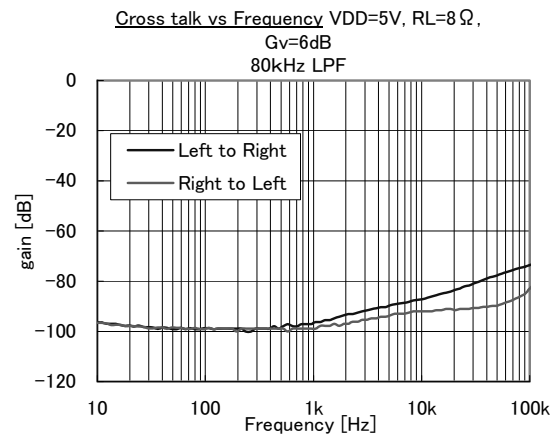

Fig.26

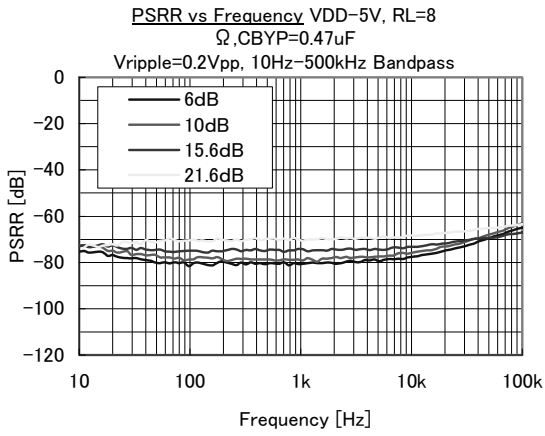

Fig.27

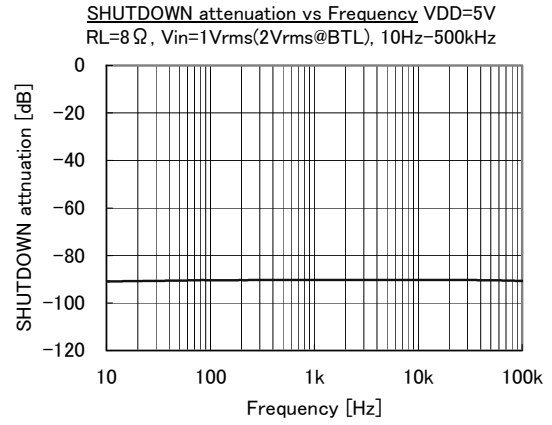

Fig.28

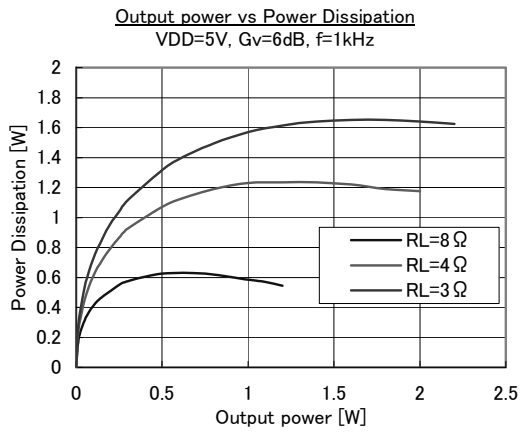

Fig.29

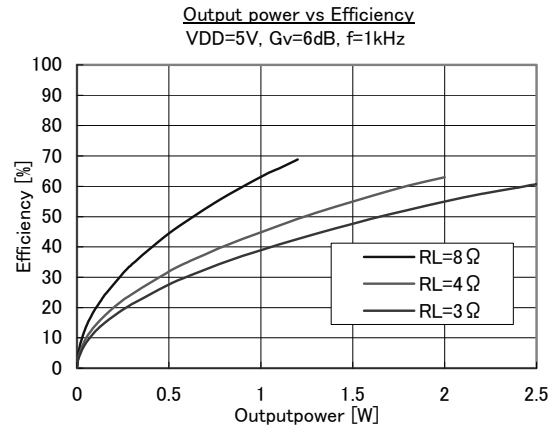

Fig.30

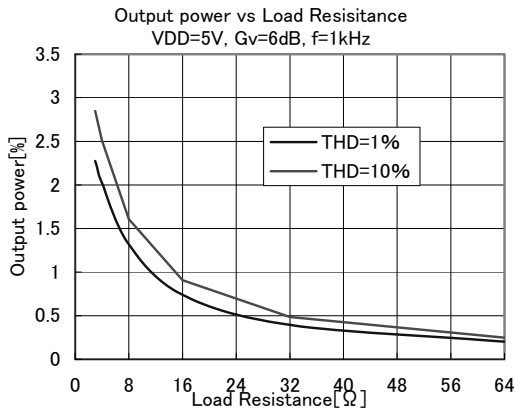
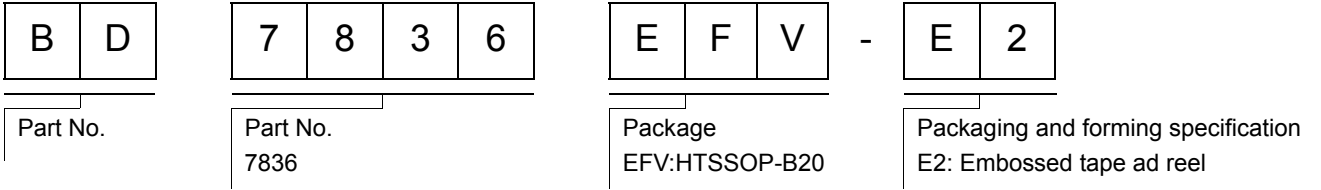

Fig.31

## ●Notes for use

- (1) Absolute maximum ratings  
This IC may be damaged if the absolute maximum ratings for the applied voltage, temperature range, or other parameters are exceeded. Therefore, avoid using a voltage or temperature that exceeds the absolute maximum ratings. If it is possible that absolute maximum ratings will be exceeded, use fuses or other physical safety measures and determine ways to avoid exceeding the IC's absolute maximum ratings.
- (2) GND terminal's potential  
Try to set the minimum voltage for GND terminal's potential, regardless of the operation mode.
- (3) Shorting between pins and mounting errors  
When mounting the IC chip on a board, be very careful to set the chip's orientation and position precisely. When the power is turned on, the IC may be damaged if it is not mounted correctly. The IC may also be damaged if a short occurs (due to a foreign object, etc.) between two pins, between a pin and the power supply, or between a pin and the GND.
- (4) Operation in strong magnetic fields  
Note with caution that operation faults may occur when this IC operates in a strong magnetic field.
- (5) Thermal design  
Ensure sufficient margins to the thermal design by taking in to account the allowable power dissipation during actual use modes, because this IC is power amp. When excessive signal inputs which the heat dissipation is insufficient condition, it is possible that thermal shutdown circuit is active
- (6) Thermal shutdown circuit  
This product is provided with a built-in thermal shutdown circuit. When the thermal shutdown circuit operates, the output transistors are placed under open status. The thermal shutdown circuit is primarily intended to shutdown the IC avoiding thermal runaway under abnormal conditions with a chip temperature exceeding  $T_{jmax} = +150^{\circ}\text{C}$ , and is not intended to protect and secure an electrical appliance
- (7) Load of the output terminal  
This IC corresponds to dynamic speaker load, and doesn't correspond to the load except for dynamic speakers.
- (8) The short protection of the output terminal  
This IC has short protection circuit. The function protects the IC from rash current on road.
- (9) Operating ranges  
The rated operating power supply voltage range ( $V_{DD}=+4.5\text{V}\sim+5.5\text{V}$ ) and the rated operating temperature range ( $T_a=-40^{\circ}\text{C}\sim+85^{\circ}\text{C}$ ) are the range by which basic circuit functions is operated. Characteristics and rated output power are not guaranteed in all power supply voltage ranges or temperature ranges.
- (10) Electrical characteristics  
Electrical characteristics show the typical performance of device and depend on board layout, parts, power supply. The standard value is in mounting device and parts on surface of ROHM's board directly.
- (11) Maximum output power  
When stereo inputs at  $R_L=4\ \Omega$ , maximum output power may not achieve up to typical value because the device heats. Ensure sufficient margins to the thermal design to get larger output power.

●Ordering part number



HTSSOP-B20

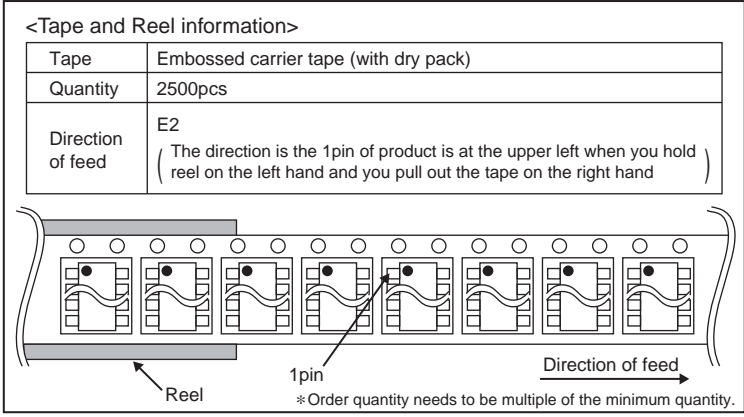
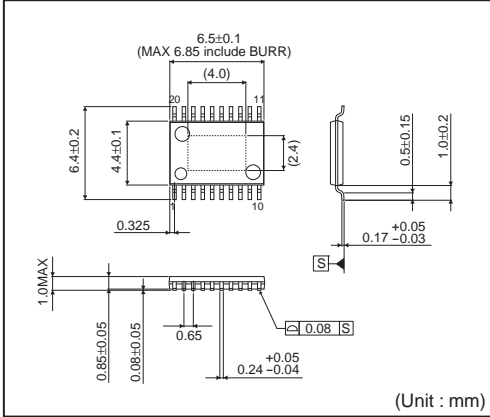



## Notes

No copying or reproduction of this document, in part or in whole, is permitted without the consent of ROHM Co.,Ltd.

The content specified herein is subject to change for improvement without notice.

The content specified herein is for the purpose of introducing ROHM's products (hereinafter "Products"). If you wish to use any such Product, please be sure to refer to the specifications, which can be obtained from ROHM upon request.

Examples of application circuits, circuit constants and any other information contained herein illustrate the standard usage and operations of the Products. The peripheral conditions must be taken into account when designing circuits for mass production.

Great care was taken in ensuring the accuracy of the information specified in this document. However, should you incur any damage arising from any inaccuracy or misprint of such information, ROHM shall bear no responsibility for such damage.

The technical information specified herein is intended only to show the typical functions of and examples of application circuits for the Products. ROHM does not grant you, explicitly or implicitly, any license to use or exercise intellectual property or other rights held by ROHM and other parties. ROHM shall bear no responsibility whatsoever for any dispute arising from the use of such technical information.

The Products specified in this document are intended to be used with general-use electronic equipment or devices (such as audio visual equipment, office-automation equipment, communication devices, electronic appliances and amusement devices).

The Products specified in this document are not designed to be radiation tolerant.

While ROHM always makes efforts to enhance the quality and reliability of its Products, a Product may fail or malfunction for a variety of reasons.

Please be sure to implement in your equipment using the Products safety measures to guard against the possibility of physical injury, fire or any other damage caused in the event of the failure of any Product, such as derating, redundancy, fire control and fail-safe designs. ROHM shall bear no responsibility whatsoever for your use of any Product outside of the prescribed scope or not in accordance with the instruction manual.

The Products are not designed or manufactured to be used with any equipment, device or system which requires an extremely high level of reliability the failure or malfunction of which may result in a direct threat to human life or create a risk of human injury (such as a medical instrument, transportation equipment, aerospace machinery, nuclear-reactor controller, fuel-controller or other safety device). ROHM shall bear no responsibility in any way for use of any of the Products for the above special purposes. If a Product is intended to be used for any such special purpose, please contact a ROHM sales representative before purchasing.

If you intend to export or ship overseas any Product or technology specified herein that may be controlled under the Foreign Exchange and the Foreign Trade Law, you will be required to obtain a license or permit under the Law.



Thank you for your accessing to ROHM product informations.  
More detail product informations and catalogs are available, please contact us.

## ROHM Customer Support System

<http://www.rohm.com/contact/>

Компания «Life Electronics» занимается поставками электронных компонентов импортного и отечественного производства от производителей и со складов крупных дистрибьюторов Европы, Америки и Азии.

С конца 2013 года компания активно расширяет линейку поставок компонентов по направлению коаксиальный кабель, кварцевые генераторы и конденсаторы (керамические, пленочные, электролитические), за счёт заключения дистрибьюторских договоров

Мы предлагаем:

- Конкурентоспособные цены и скидки постоянным клиентам.
- Специальные условия для постоянных клиентов.
- Подбор аналогов.
- Поставку компонентов в любых объемах, удовлетворяющих вашим потребностям.
- Приемлемые сроки поставки, возможна ускоренная поставка.
- Доставку товара в любую точку России и стран СНГ.
- Комплексную поставку.
- Работу по проектам и поставку образцов.
- Формирование склада под заказчика.
- Сертификаты соответствия на поставляемую продукцию (по желанию клиента).
- Тестирование поставляемой продукции.
- Поставку компонентов, требующих военную и космическую приемку.
- Входной контроль качества.
- Наличие сертификата ISO.

В составе нашей компании организован Конструкторский отдел, призванный помогать разработчикам, и инженерам.

Конструкторский отдел помогает осуществить:

- Регистрацию проекта у производителя компонентов.
- Техническую поддержку проекта.
- Защиту от снятия компонента с производства.
- Оценку стоимости проекта по компонентам.
- Изготовление тестовой платы монтаж и пусконаладочные работы.



Тел: +7 (812) 336 43 04 (многоканальный)

Email: [org@lifeelectronics.ru](mailto:org@lifeelectronics.ru)