

System Lens Drivers



# μ-step System Lens Driver for Digital Still Cameras

## BU24025MWV

● **General Description**

BU24025MWV is a system Lens Driver that uses μ-step driving to make the configuration of the sophisticated, high precision and low noise lens driver system possible. This IC has a built-in driver for both DC motor and voice coil motor and a μ-step controller that decreases CPU power. Therefore, multifunctional lens can be applied.

● **Key Specifications**

- Digital Power Supply Voltage: 2.7V to 3.6V
- Driver Power Supply Voltage: 2.7V to 5.5V
- Output Current (1ch-7ch): ±500mA(Max)
- Input Clock Frequency: 1MHz to 27.5MHz
- FET ON Resistance (1ch-5ch): 1.5Ω(Typ)
- FET ON Resistance (6ch,7ch): 1.1Ω(Typ)
- Operating Temperature Range: -10°C to +85°C

● **Features**

- Built-in 7 channels Driver block
  - 1ch-5ch: Voltage control type H-bridge  
(Adaptable to STM 2systems)
  - 6ch,7ch: Current control type H-bridge

● **Applications**

- Digital still cameras

● **Package**

UQFN044V6060 6.00mm x 6.00mm x 1.00mm

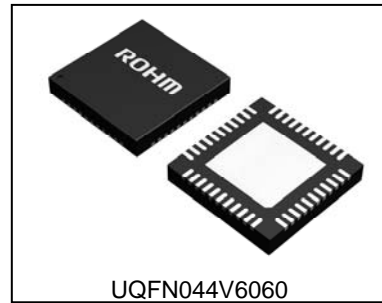

● **Typical Application Circuit**

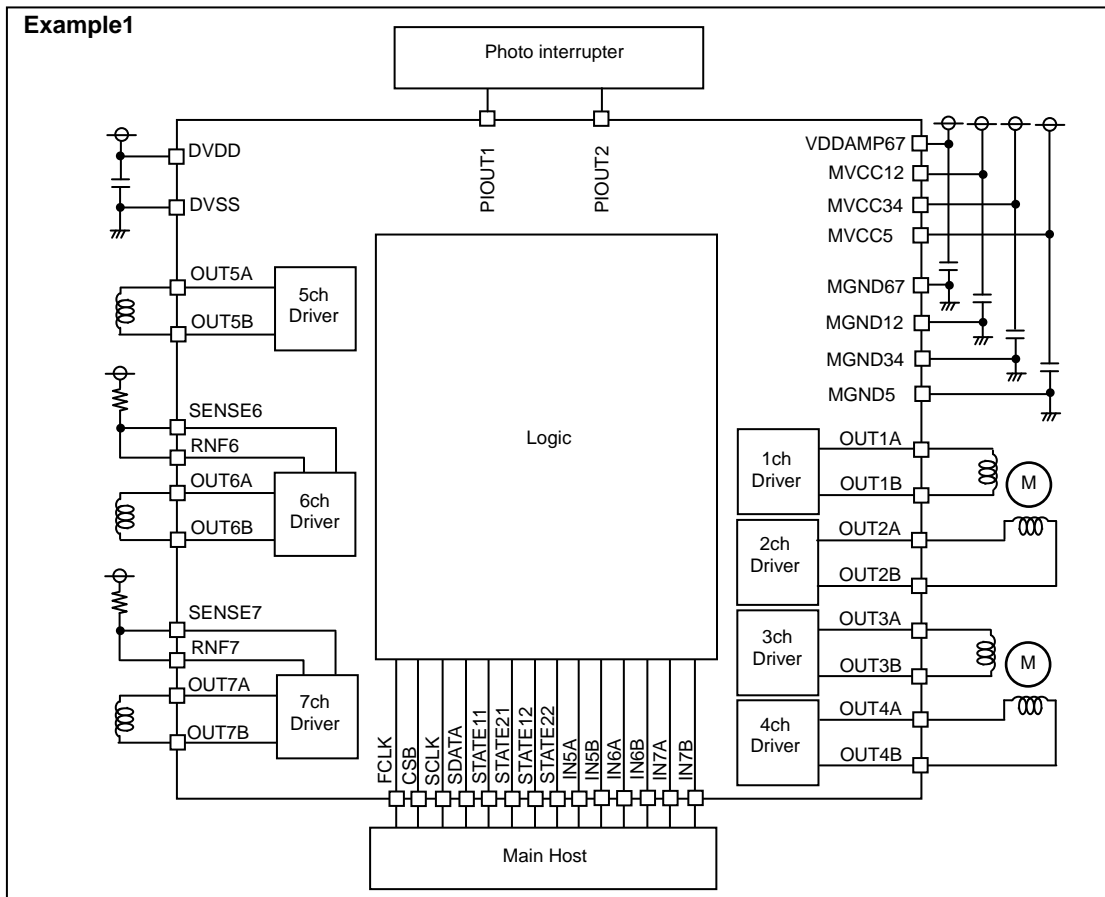

○Product structure : Silicon monolithic integrated circuit ○This product is not designed for protection against radioactive rays

### ● Pin Configuration (Top view)

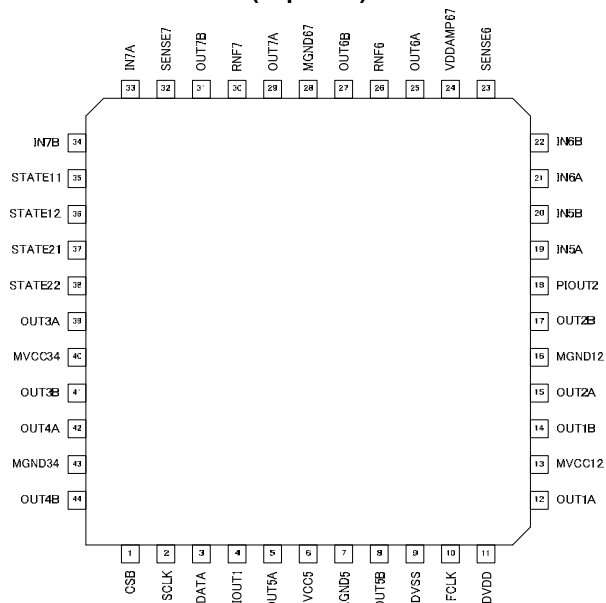

### ● Pin Description

No.	Pin Name	Power Supply	Function	No.	Pin Name	Power Supply	Function
1	CSB	DVDD	CSB logic input	23	SENSE6	VDDAMP67	Negative input for 6ch current driver
2	SCLK	DVDD	SCLK logic input	24	VDDAMP67	-	Power supply of 6-7channel current driver control
3	SDATA	DVDD	SDATA logic input	25	OUT6A	RNF6	6-channel driver A output
4	PIOUT1	DVDD	PI driving output1	26	RNF6	RNF6	6-channel driver power supply
5	OUT5A	MVCC5	5-channel driver A output	27	OUT6B	RNF6	6-channel driver B output
6	MVCC5	-	5-channel driver power supply	28	MGND67	-	6-7channel driver ground
7	MGND5	-	5-channel driver ground	29	OUT7A	RNF7	7-channel driver A output
8	OUT5B	MVCC5	5-channel driver B output	30	RNF7	RNF7	7-channel driver power supply
9	DVSS	-	Digital ground	31	OUT7B	RNF7	7-channel driver B output
10	FCLK	DVDD	FCLK logic input	32	SENSE7	VDDAMP67	Negative input for 7ch current driver
11	DVDD	-	Digital power supply	33	IN7A	DVDD	IN7A logic input
12	OUT1A	MVCC12	1-channel driver A output	34	IN7B	DVDD	IN7B logic input
13	MVCC12	-	1-2channel driver power supply	35	STATE11	DVDD	STATE11 logic output
14	OUT1B	MVCC12	1-channel driver B output	36	STATE12	DVDD	STATE12 logic output
15	OUT2A	MVCC12	2-channel driver A output	37	STATE21	DVDD	STATE21 logic output
16	MGND12	-	1-2channel driver ground	38	STATE22	DVDD	STATE22 logic output
17	OUT2B	MVCC12	2-channel driver B output	39	OUT3A	MVCC34	3-channel driver A output
18	PIOUT2	DVDD	PI driving output2	40	MVCC34	-	3-4channel driver power supply
19	IN5A	DVDD	IN5A logic input	41	OUT3B	MVCC34	3-channel driver B output
20	IN5B	DVDD	IN5B logic input	42	OUT4A	MVCC34	4-channel driver A output
21	IN6A	DVDD	IN6A logic input	43	MGND34	-	3-4channel driver ground
22	IN6B	DVDD	IN6B logic input	44	OUT4B	MVCC34	4-channel driver B output

●Block Diagram

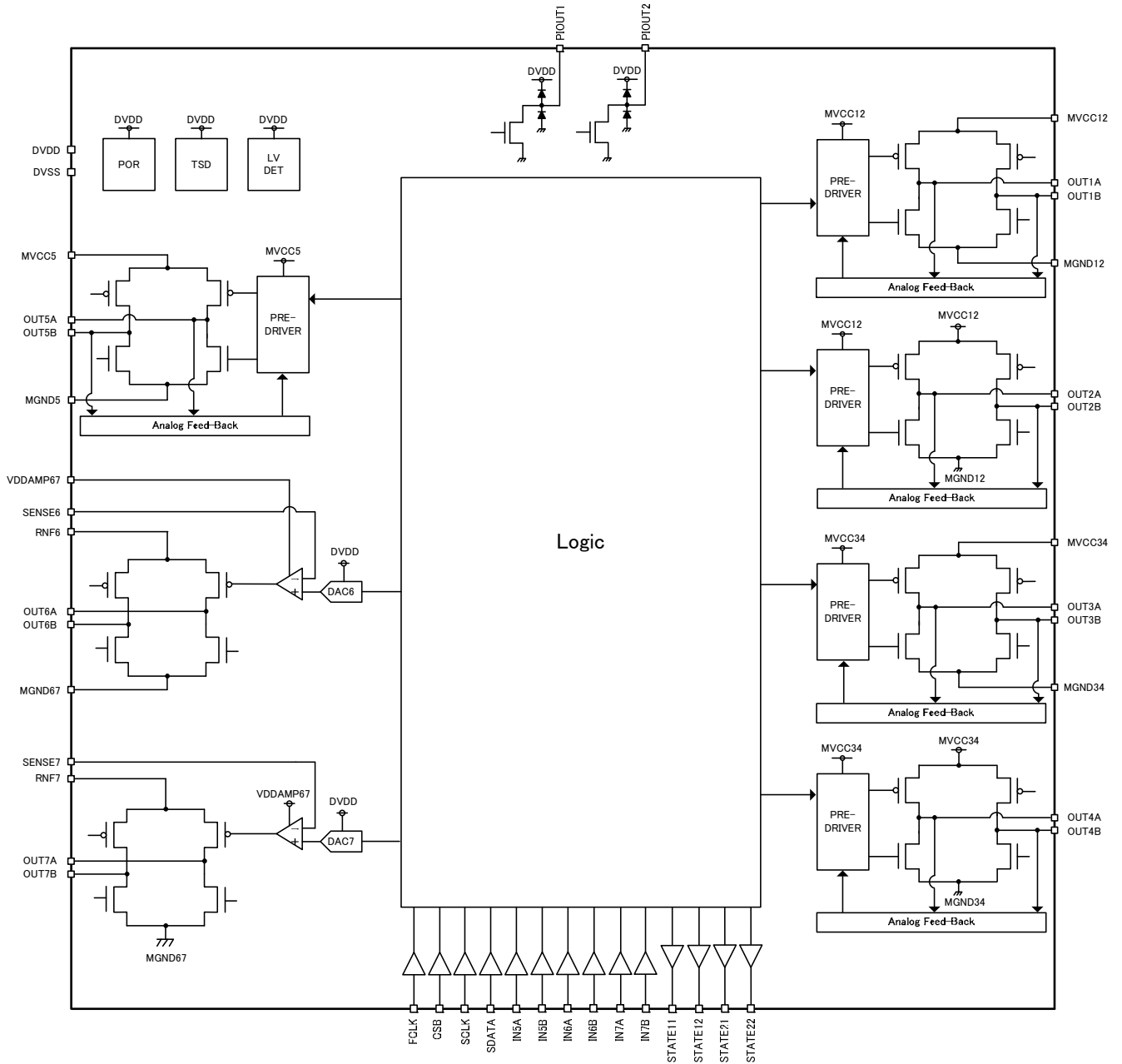

## ●Description of Blocks

### Stepping Motor Driver (1ch-4ch Driver)

Built-in stepping motor driver of PWM driving type.

Maximum 2 stepping motors can be driven independently.

Built-in voltage feedback circuit of D-class type.

3ch/4ch drivers can also drive independently for DC motor or voice coil motor.

### (1) Control

#### ( i ) Autonomous control

The stepping motor is rotated by setting the registers for the stepping motor control.

It is possible to select the mode of stepping motor control from  $\mu$ -step (1024 portion), 1-2 phase excitation and 2 phase excitation.

Built-in Cache registers.

Cache registers enable the setting of subsequent process while the motor is in operation. Through these registers, operations are done continuously.

The state of the rotation command (ACT), state of Cache registers (BUSY), motor operation position (MO) and state of excitation (MO & ACT) are synchronized with the motor rotation and can be selected to be the output of the STATE pin.

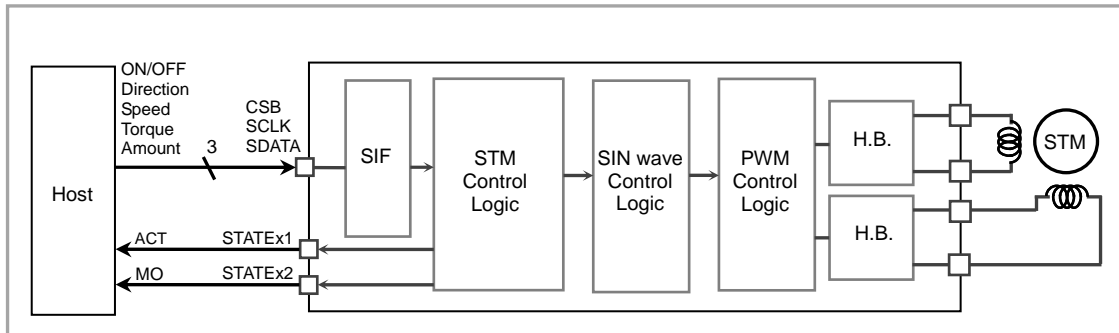

●Description of Blocks

Voltage Driver (5ch Driver)

Built-in voltage driver of PWM driving type.

(1) Control

( i )Register Control

The PWM drive is executed by the PWM duty ratio, the PWM direction and the PWM ON/OFF which are controlled by the register settings.

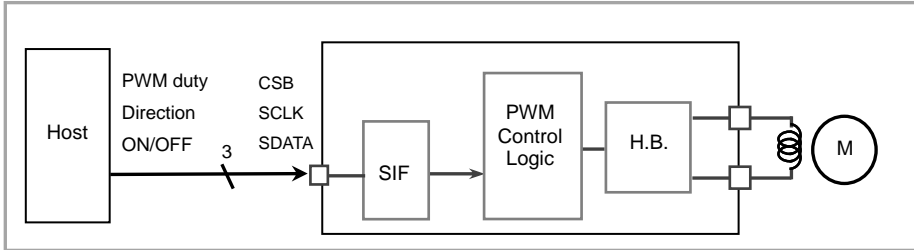

( ii )External Pin Control 1

The PWM drive is executed by the PWM duty ratio, the PWM direction and the PWM ON/OFF which are controlled by IN5A/IN5B pin.

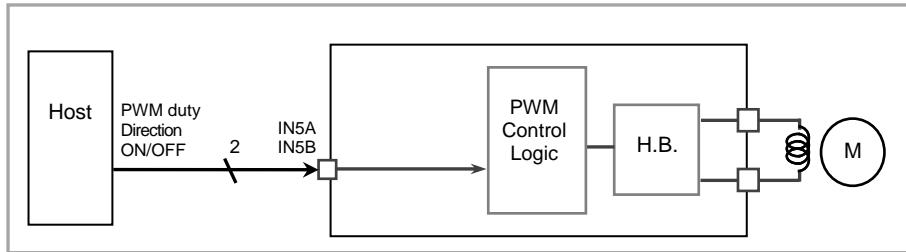

( iii )External Pin Control 2

The PWM drive is executed by the PWM duty ratio which is controlled by the register setting. The PWM direction and PWM ON/OFF are controlled by IN5A/IN5B pin.

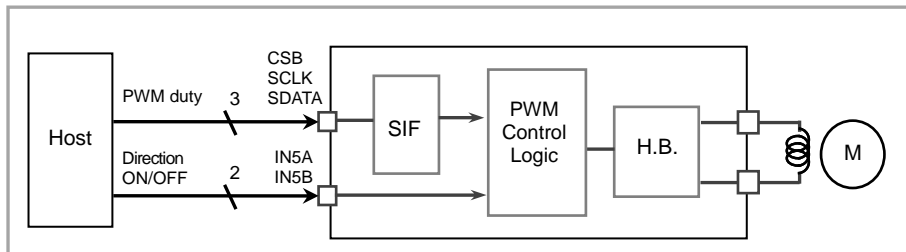

●Description of Blocks

Current Driver (6ch, 7ch Driver)

Built-in constant current driver.

The voltage of RNF pin and the external resistor (RRNF) determine the amount output current. The internal high-precision amplifier (CMOS gate input) is used for constant current control. If any resistance component exists in the wirings of RNF pin and the external resistor (RRNF), the precision can be reduced. To avoid this, pay utmost attention to the wirings.

(1) Control

( i ) Register Control

The constant current drive is executed by the output current value, the current direction and the current ON/OFF which are controlled by the register settings.

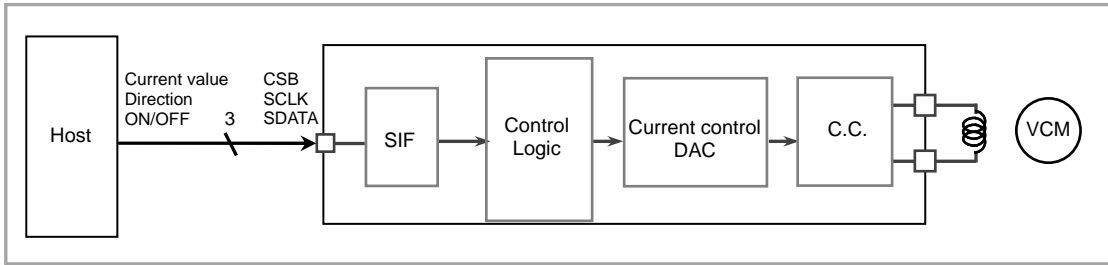

( ii ) External Pin Control

The constant current drive is executed by the output current value which is controlled by the register setting. Constant current driving direction and turning ON/OFF are controlled by INxA/INxB pin.

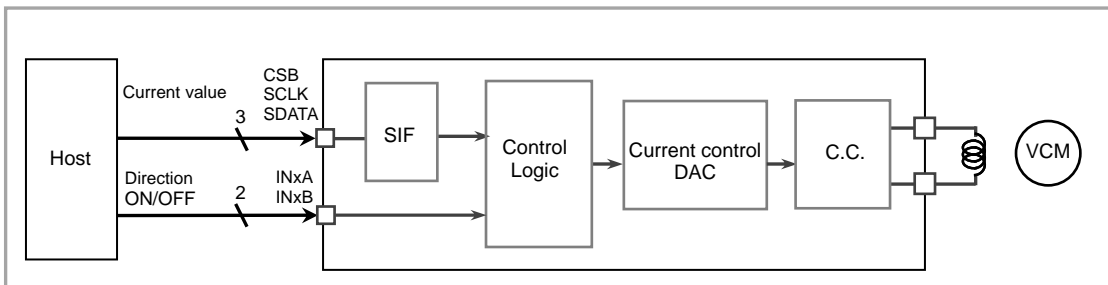

**●Absolute Maximum Ratings (Ta=25°C)**

Parameter	Symbol	Limit	Unit	Remark
Power Supply Voltage	DVDD	-0.3 to +4.5	V	
	MVCC	-0.3 to +7.0	V	
Input Voltage	VIN	-0.3 to supply voltage+0.3	V	
Input / Output Current	IIN	±500	mA	Driver block (by MVCC pin)
		+50	mA	by PIOUT pin
Storage Temperature Range	TSTG	-55 to +125	°C	
Operating Temperature Range	TOPE	-10 to +85	°C	
Permissible Dissipation <sup>*1</sup>	PD	3000	mW	

\*1 To use at a temperature higher than Ta=25 °C, derate 30mW per 1 °C  
(At mounting ROHM's standard board : 74.2mmx74.2mmx1.6mm/4 layer Board )

**●Recommended Operating Rating (Ta=25°C)**

Parameter	Symbol	Limit	Unit	Remark
Digital Power Supply Voltage	DVDD	2.7 to 3.6	V	DVDD ≤ MVCC
Driver Power Supply Voltage	MVCC	2.7 to 5.5	V	
Clock Operating Frequency	FCLK	1 to 27.5	MHz	Reference clock

### ●Electrical Characteristics

(Unless otherwise specified, Ta=25°C, DVDD=3.0V, MVCC=5.0V, DVSS=MGND=0.0V)

Parameter	Symbol	Limit			Unit	Conditions
		MIN	TYP	MAX		
<Current Consumption>						
Quiescence (DVDD)	ISSD	-	0.45	1.5	mA	CMD_RS=0
	(MVCC) ISSVM	-	50	100	μA	
Operation (DVDD)	IDDD	-	6	10	mA	
<Logic Block>						
Low-level Input Voltage	VIL	DVSS	-	0.3DVDD	V	
High-level Input Voltage	VIH	0.7DVDD	-	DVDD	V	
Low-level Input Current	IIL	0	-	10	μA	VIL=DVSS
High-level Input Current	IIH	0	-	10	μA	VIH=DVDD
Low-level Output Voltage	VOL	DVSS	-	0.2DVDD	V	IOL=1.0mA
High-level Output Voltage	VOH	0.8DVDD	-	DVDD	V	IOH=1.0mA
<PI Driving Circuit>						
Output Voltage	PIVO	-	0.16	0.50	V	IIH=30mA
<Voltage Driver Block >						
ON-resistance	Ron	-	1.5	2.0	Ω	IO=±100mA (the sum of high and low sides)
OFF-leak Current	IOZ	-10	0	+10	μA	Output Hiz setting
Average Voltage Accuracy between different Output Pins	Vdiff	-5	-	+5	%	Vdiff setting : 2Bh
<Current Driver Block >						
ON-resistance	Ron	-	1.1	1.5	Ω	IO=±100mA (the sum of high and low sides)
OFF-leak Current	IOZ	-10	0	+10	μA	Output Hiz setting
Output Current	IO	190	200	210	mA	DAC setting : 80h RRNF=1Ω



● Typical Performance Curves

(Unless otherwise specified, Ta=25°C, DVDD=3.0V, MVCC=5.0V, DVSS=MGND=0.0V)

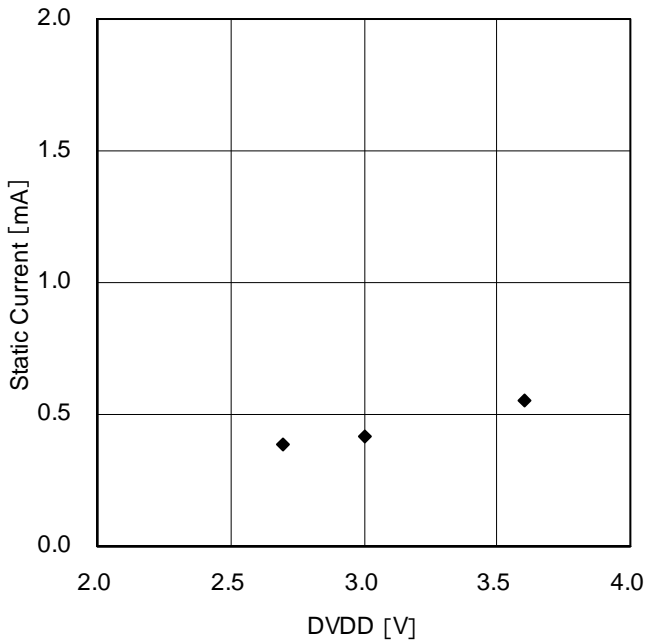

Figure 1. DVDD Static Current Voltage Dependency

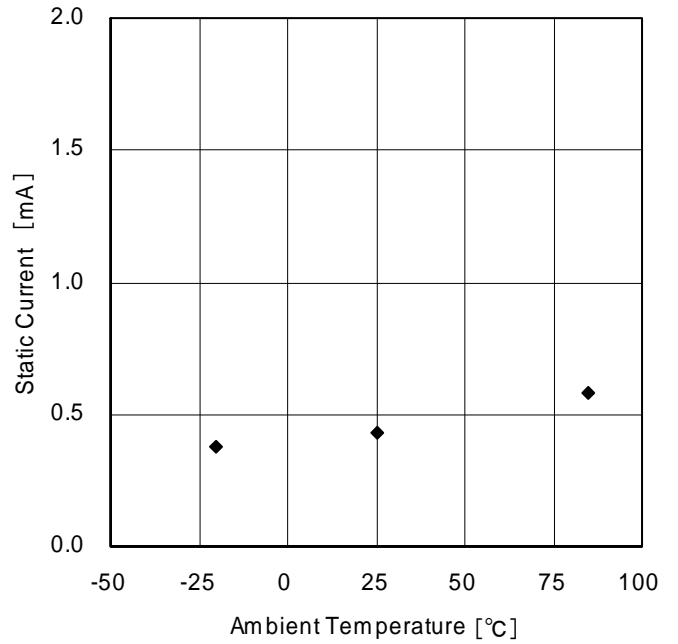

Figure 2. DVDD Static Current Temperature Dependency

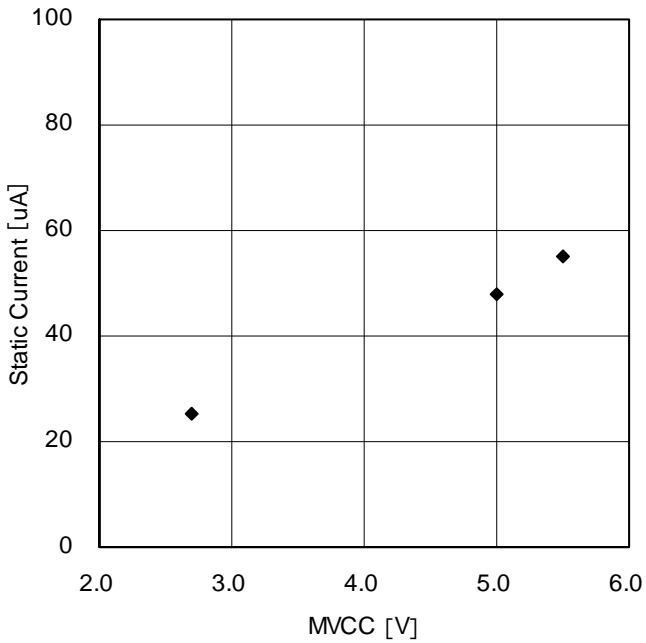

Figure 3. MVCC Static Current Voltage Dependency

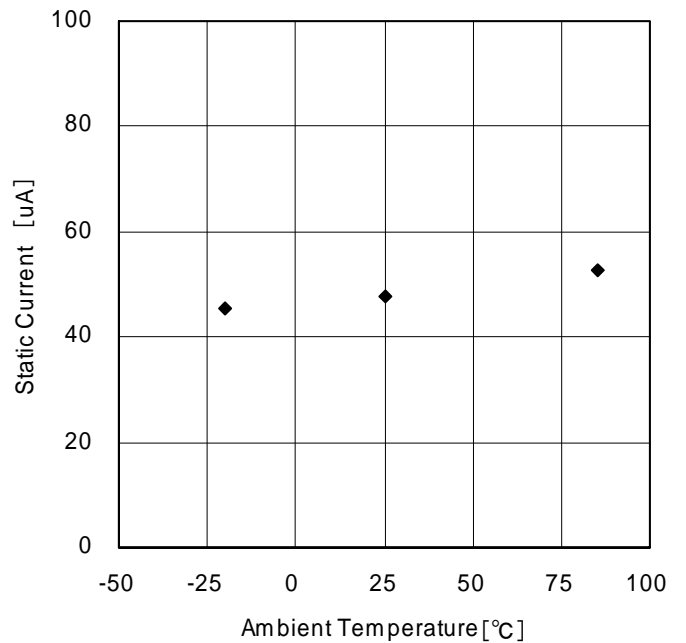

Figure 4. MVCC Static Current Temperature Dependency

● Typical Performance Curves

(Unless otherwise specified, Ta=25°C, DVDD=3.0V, MVCC=5.0V, DVSS=MGND=0.0V)

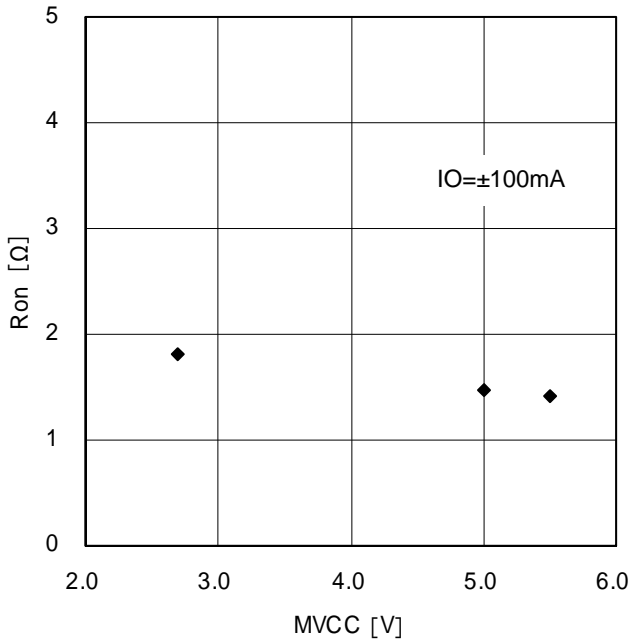

Figure 5. Output ON-Resistance  
MVCC Dependency  
(Voltage driver block)

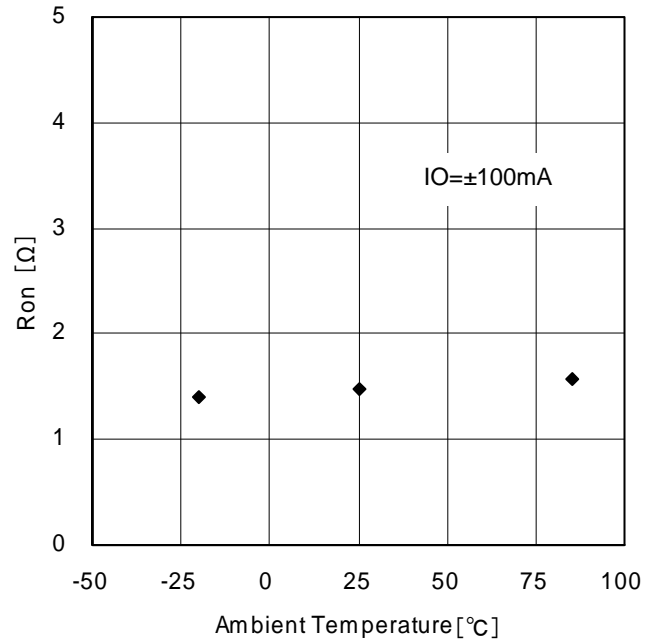

Figure 6. Output ON-Resistance  
Temperature Dependency  
(Voltage driver block)

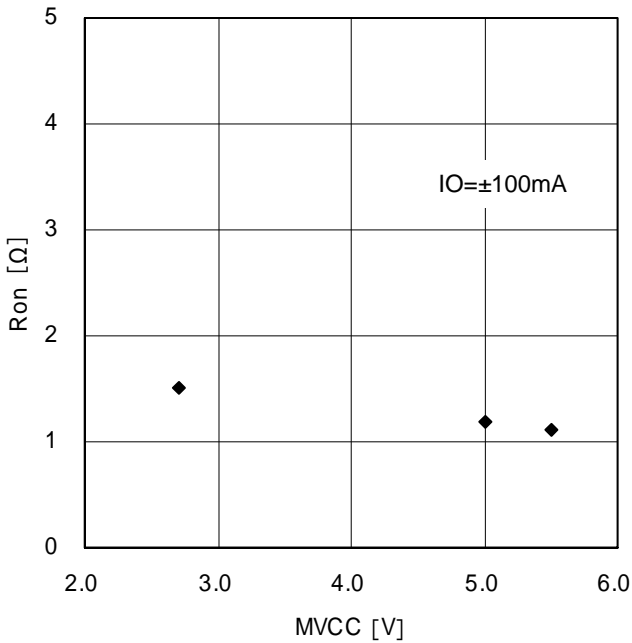

Figure 7. Output ON-Resistance  
MVCC Dependency  
(Current driver block)

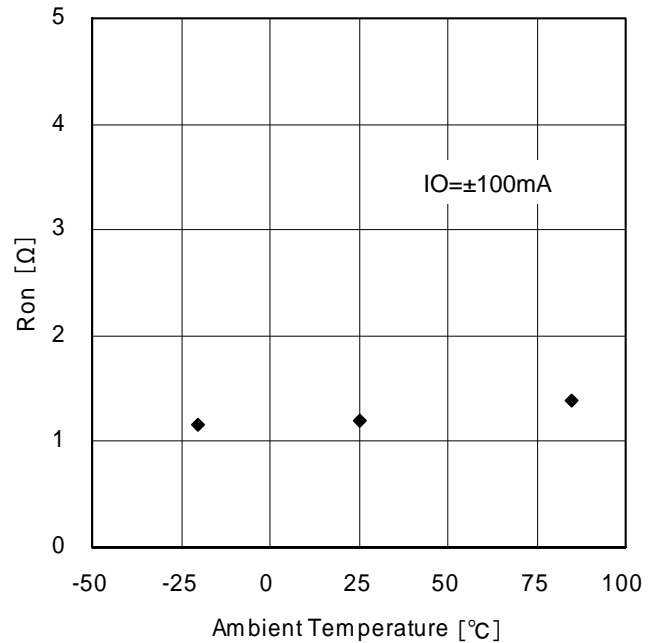

Figure 8. Output ON-Resistance  
Temperature Dependency  
(Current driver block)

● Typical Performance Curves

(Unless otherwise specified,  $T_a=25^\circ\text{C}$ ,  $DVDD=3.0\text{V}$ ,  $MVCC=5.0\text{V}$ ,  $DVSS=MGND=0.0\text{V}$ )

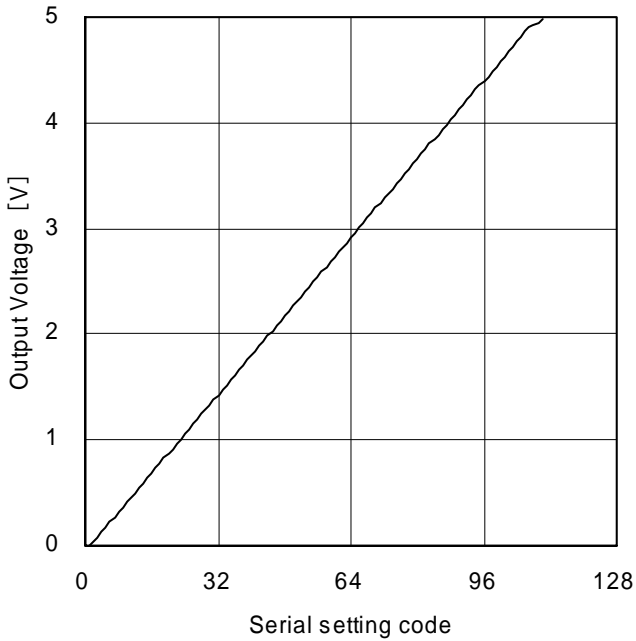

Figure 9. Average Voltage Accuracy between different output pins (Voltage driver block)

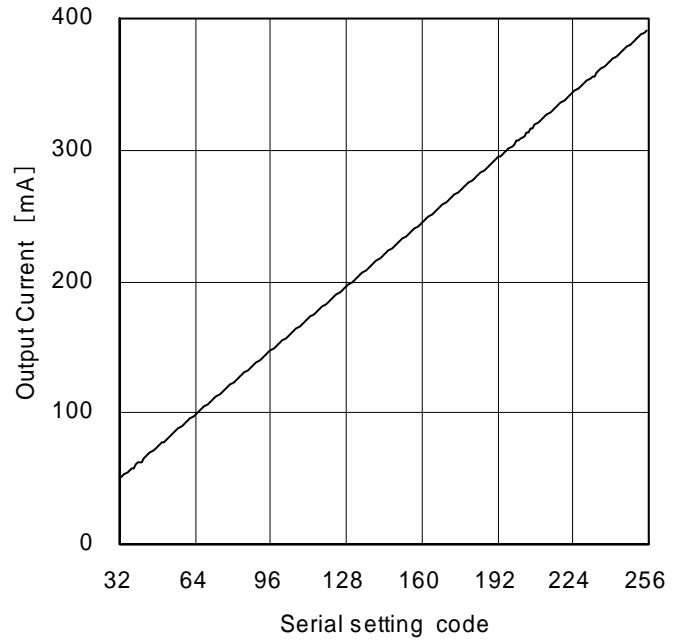

Figure 10. Output Current (Current driver block,  $RRNF = 1.0\Omega$ ,  $RL = 5.0\Omega$ )

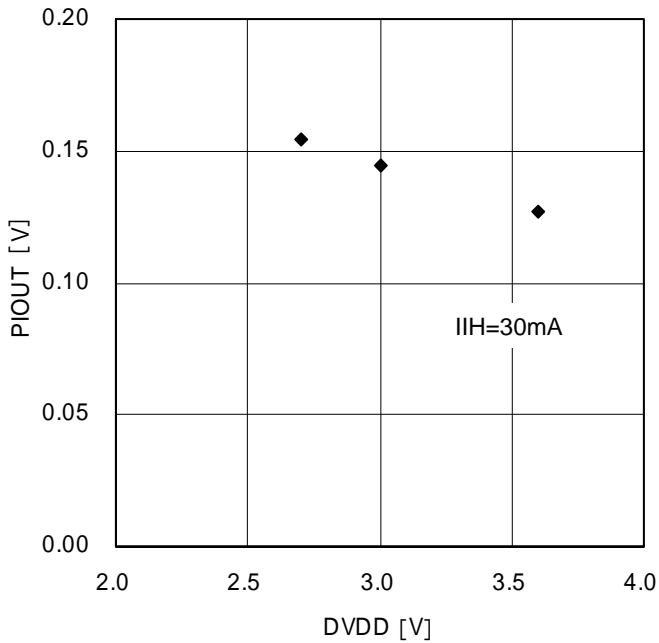

Figure 11. Output Voltage DVDD Dependency (PI driving circuit)

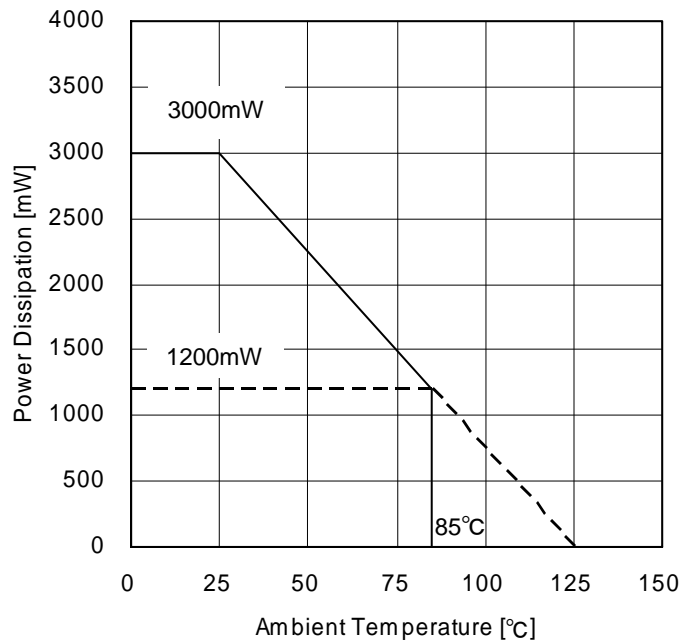
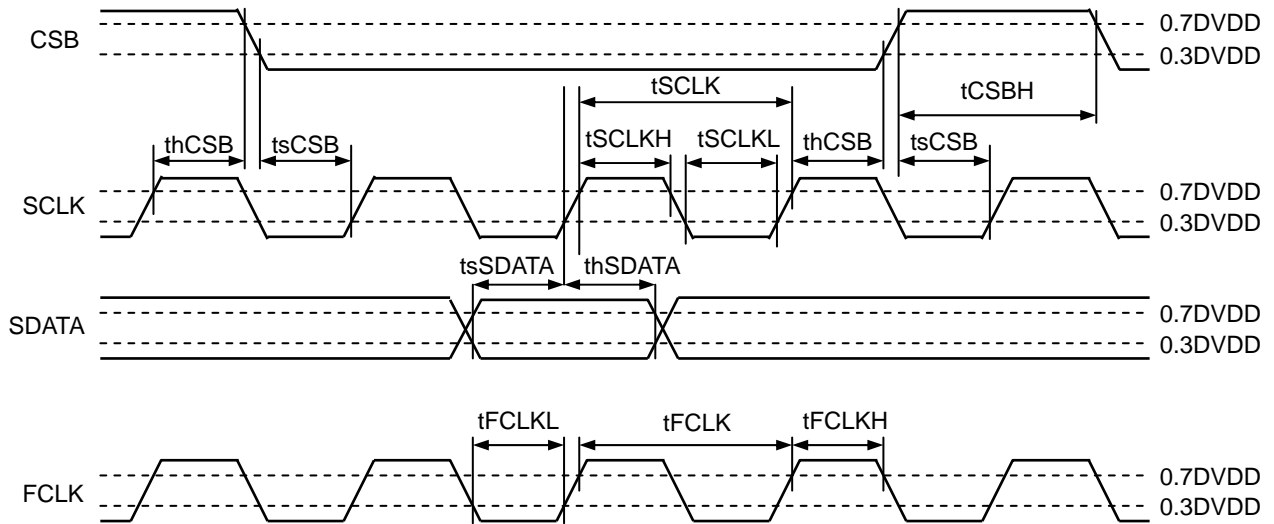

Figure 12. Power Dissipation Curve

●Timing Chart

(Unless otherwise specified, Ta=25°C, DVDD=3.0V)

Parameter	Symbol	Specification
SCLK input cycle	tSCLK	More than 125 nsec
SCLK L-level input time	tSCLKL	More than 50 nsec
SCLK H-level input time	tSCLKH	More than 50 nsec
SDATA setup time	tsSDATA	More than 50 nsec
SDATA hold time	thSDATA	More than 50 nsec
CSB H-level input time	tCSBH	More than 380 nsec
CSB setup time	tsCSB	More than 50 nsec
CSB hold time	thCSB	More than 50 nsec
FCLK input cycle	tFCLK	More than 36 nsec
FCLK L-level input time	tFCLKL	More than 18 nsec
FCLK H-level input time	tFCLKH	More than 18 nsec



(note1) FCLK is asynchronous with SCLK.  
 (note2) Duty of FCLK, SCLK are free.

●Serial interface

Control commands are framed by a 16-bit serial input (MSB first) and are sent through the CSB, SCLK, and SDATA pins. The 4 higher-order bits specify addresses, while the remaining 12 bits specify data. Data of every bit is sent through SDATA pin, which is retrieved during the rising edge of SCLK. Data becomes valid when CSB is Low. The load timing is different for resistors. (as shown in "Note4,5")

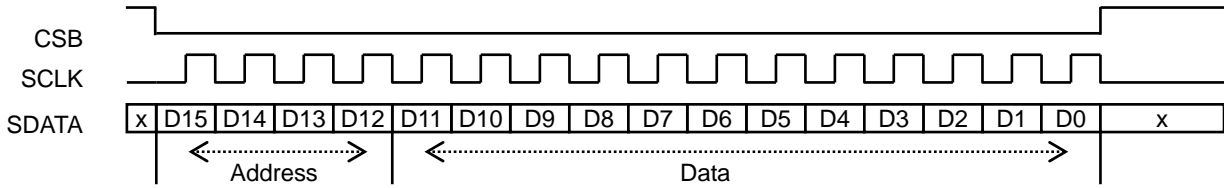

<Register map>

Address[3:0]				Data[11:0]											
15	14	13	12	11	10	9	8	7	6	5	4	3	2	1	0
0	0	0	0	ModeA[1:0]		SelA[1:0]		0	Ach_different_output_voltage[6:0]						
0	0	0	1	0	0	0	0	Ach_Cycle[7:0]							
				0	0	1	0	Ach_Cycle[15:8]							
				0	1	1	0	A_BEEXC	0	0	A_BSL	A_AEXC	0	0	A_AS_L
				1	1	1	0	0	0	APOS[1:0]	0	0	0	ASTOP	
0	0	1	0	EnA	RtA	Ach_Pulse[9:0]									
0	0	1	1	0	0	0	0	0	0	0	0	0	0	0	0
0	1	0	0	0	0	0	0	0	0	0	0	0	0	0	0
0	1	0	1	0	0	0	0	0	0	0	0	0	0	0	0
0	1	1	0	0	0	0	0	0	0	0	0	0	0	0	0
0	1	1	1	0	0	0	0	0	0	0	0	0	0	0	0
1	0	0	0	ModeB[1:0]		SelB[1:0]		0	Bch_different_output_voltage[6:0]						
1	0	0	1	0	0	0	0	Bch_Cycle[7:0]							
				0	0	1	0	Bch_Cycle[15:8]							
				0	1	1	0	B_BEEXC	0	0	B_BSL	B_AEXC	0	0	B_AS_L
				1	0	0	0	0	0	3_Chop[1:0]	0	0	4_Chop[1:0]		
				1	0	1	3_PWM_Ct[1:0]		3ch_PWM_Duty[6:0]						
				1	1	0	4_PWM_Ct[1:0]		4ch_PWM_Duty[6:0]						
				1	1	1	0	0	0	BPOS[1:0]	0	0	0	BSTOP	
1	0	1	0	EnB	RtB	Bch_Pulse[9:0]									
1	0	1	1	0	0	0	0	0	0	0	0	0	0	0	0
1	1	0	0	0	0	Chopping[1:0]		CacheM	0	0	Isel	P_CTRL	CLK_DIV[2:0]		
1	1	0	1	0	0	0	0	0	0	0	0	0	0	PI_CTRL1	PI_CTRL2
				0	0	1	0	0	0	0	0	0	5_Sel[1:0]	5_Chop[1:0]	
				0	1	0	5_PWM_Ct[1:0]		5ch_PWM_Duty[6:0]						
1	1	1	0	0	0	0	0	Current driver reference voltage adjustment6 (DAC6 output value) [7:0]							
				0	1	0	0	7ch_S	0	7_PWM_Ct[1:0]	6ch_S	0	6_PWM_Ct[1:0]		
				1	0	0	0	Current driver reference voltage adjustment7 (DAC7 output value) [7:0]							
				1	1	0	0	0	0	0	0	0	0	0	CMD_RS
Addresses other than those above				Setting prohibited											

- (Note 1) The notations A, B, in the register map correspond to Ach, Bch respectively.
- (Note 2) The Ach is defined as 1ch and 2ch driver output, the Bch as 3ch and 4ch driver output.
- (Note 3) After reset (Power ON reset, and CMD\_RS), "initial setting" is saved in all registers.
- (Note 4) For Mode, different output voltage, Cycle, En, and Rt registers, data that are written before the access to the Pulse register becomes valid, and determines the rising edge of CSB after the access to the Pulse register. (The Mode, different output voltage, Cycle, En, Rt, and Pulse registers contain Cache registers. Any registers other than those do not contain Cache registers.)
- (Note 5) For POS, STOP, chop, PWM\_Ct, and PWM\_duty registers, data are determined at the rising edge of CSB. For any registers other than those, data are determined at the rising edge of 16th SCLK.

●Application Example

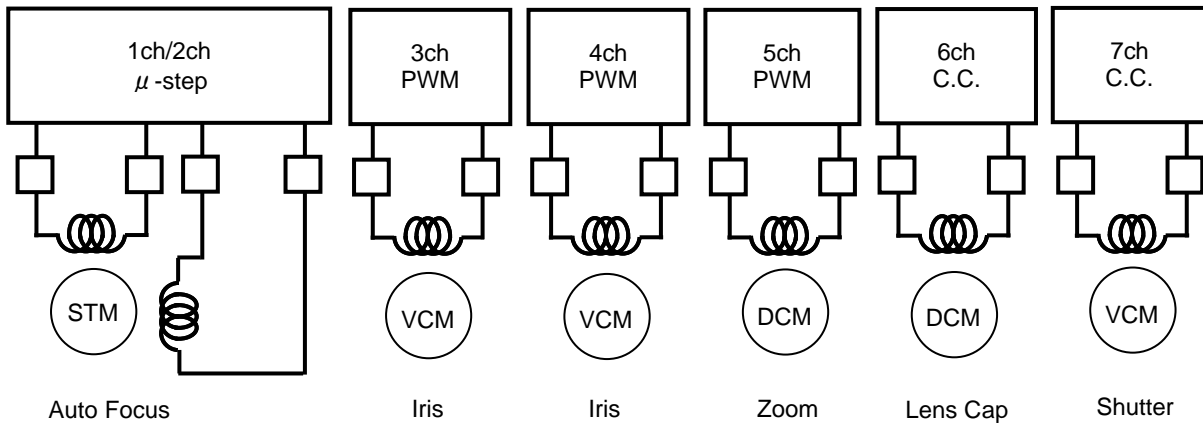
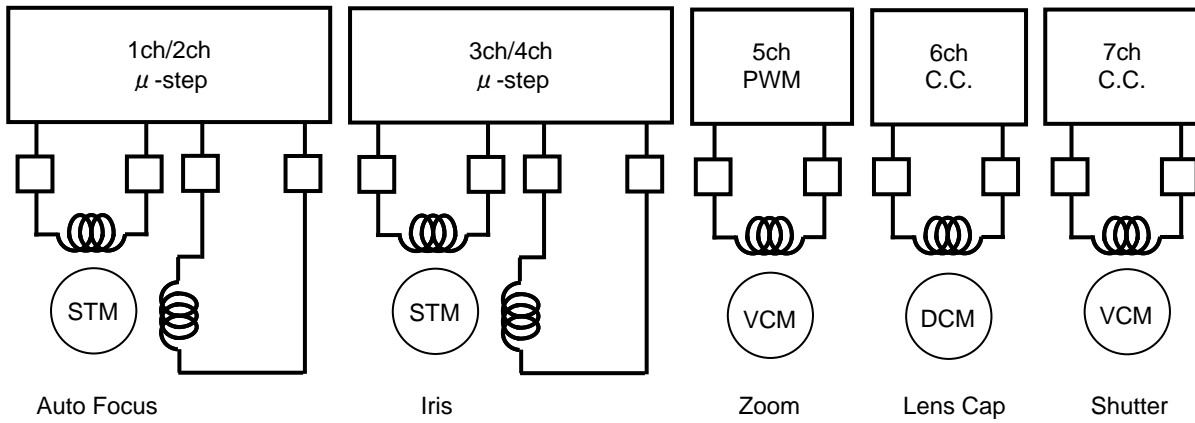

● I/O Equivalence Circuit

Pin	Equivalent Circuit Diagram	Pin	Equivalent Circuit Diagram
FCLK CSB SCLK SDATA IN5A IN5B IN6A IN6B IN7A IN7B		PIOUT1 PIOUT2	
STATE11 STATE12 STATE21 STATE22		OUT1A OUT1B OUT2A OUT2B	
OUT3A OUT3B OUT4A OUT4B		OUT5A OUT5B	
OUT6A OUT6B		OUT7A OUT7B	
SENSE6		SENSE7	

**●Operational Notes**

- 1) Absolute maximum ratings  
If applied voltage, operating temperature range, or other absolute maximum ratings are exceeded, the LSI may be damaged. Do not apply voltages or temperatures that exceed the absolute maximum ratings. If you expect that any voltage or temperature could be exceeding the absolute maximum ratings, take physical safety measures such as fuses to prevent any conditions exceeding the absolute maximum ratings from being applied to the LSI.
- 2) GND potential  
The voltage of the ground pin must be the lowest voltage of all pins of the IC at all operating conditions. Ensure that no pins are at a voltage below the ground pin at any time, even during transient condition.
- 3) Thermal design  
Use a thermal design that allows for a sufficient margin by taking into account the permissible power dissipation (PD) in actual operating conditions.
- 4) Short circuit between pins and malfunctions  
Ensure that when mounting the IC on the PCB the direction and position are correct. Incorrect mounting may result in damaging the IC. Avoid nearby pins being shorted to each other especially to ground. Inter-pin shorts could be due to many reasons such as metal particles, water droplets (in very humid environment) and unintentional solder bridge deposited in between pins during assembly to name a few.
- 5) Operation in strong magnetic field  
Operating the IC in the presence of a strong electromagnetic field may cause the IC to malfunction.
- 6) Power ON sequence  
To turn ON the DVDD, be sure to reset at CMD\_RS register.
- 7) Thermal shutdown  
The IC incorporates a built-in thermal shutdown circuit, which is designed to turn off the IC when the internal temperature of the IC reaches a specified value. It is not designed to protect the IC from damage or guarantee its operation. Do not continue to operate the IC after this function is activated. Do not use the IC in conditions where this function will always be activated.
- 8) PI drive circuit  
The output voltage of PIOOUT should not exceed the voltage of the power supply voltage DVDD.



●Ordering Information

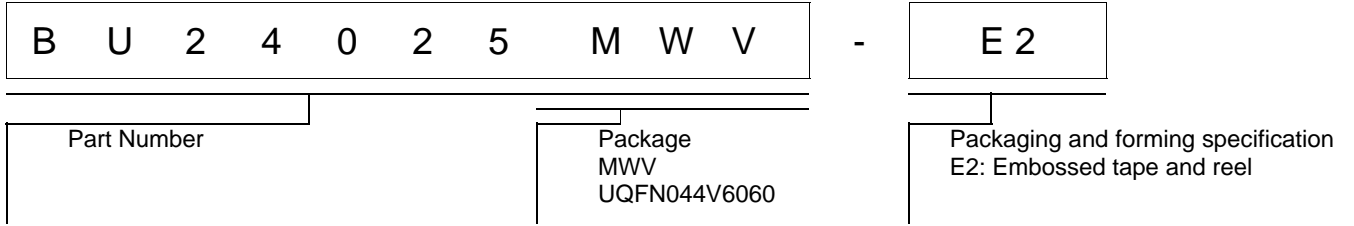

●Physical Dimension Tape and Reel Information

UQFN044V6060

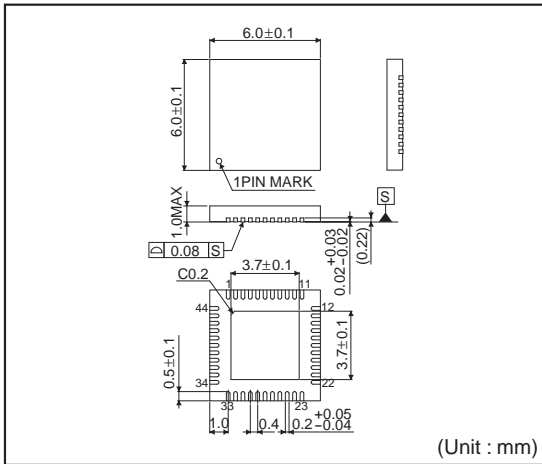

<Tape and Reel information>

Tape	Embossed carrier tape
Quantity	2000pcs
Direction of feed	E2 ( The direction is the 1pin of product is at the upper left when you hold reel on the left hand and you pull out the tape on the right hand )

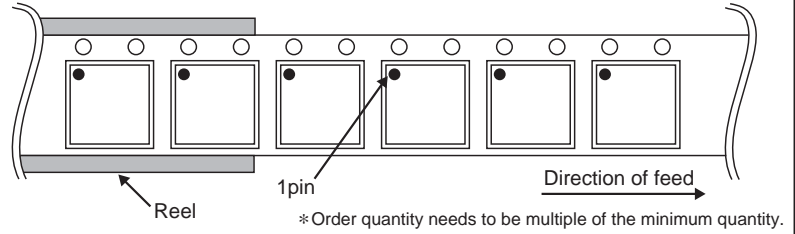

●Marking Diagram

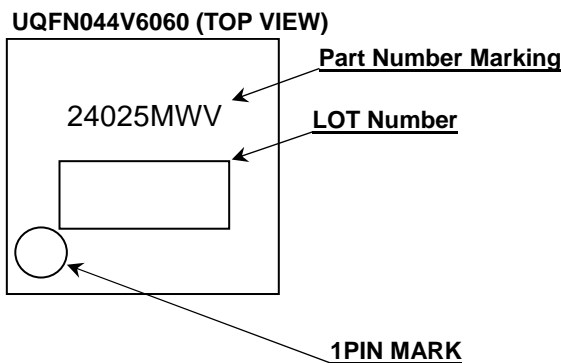

●Revision History

Date	Revision	Changes
26.Sep.2012	001	New Release
18.Apr.2013	002	Update some English words, sentences, description, grammar and formatting.

# Notice

## Precaution on using ROHM Products

- Our Products are designed and manufactured for application in ordinary electronic equipments (such as AV equipment, OA equipment, telecommunication equipment, home electronic appliances, amusement equipment, etc.). If you intend to use our Products in devices requiring extremely high reliability (such as medical equipment <sup>(Note 1)</sup>, transport equipment, traffic equipment, aircraft/spacecraft, nuclear power controllers, fuel controllers, car equipment including car accessories, safety devices, etc.) and whose malfunction or failure may cause loss of human life, bodily injury or serious damage to property ("Specific Applications"), please consult with the ROHM sales representative in advance. Unless otherwise agreed in writing by ROHM in advance, ROHM shall not be in any way responsible or liable for any damages, expenses or losses incurred by you or third parties arising from the use of any ROHM's Products for Specific Applications.

(Note1) Medical Equipment Classification of the Specific Applications

JAPAN	USA	EU	CHINA
CLASS III	CLASS III	CLASS II b	CLASS III
CLASS IV		CLASS III	

- ROHM designs and manufactures its Products subject to strict quality control system. However, semiconductor products can fail or malfunction at a certain rate. Please be sure to implement, at your own responsibilities, adequate safety measures including but not limited to fail-safe design against the physical injury, damage to any property, which a failure or malfunction of our Products may cause. The following are examples of safety measures:
  - Installation of protection circuits or other protective devices to improve system safety
  - Installation of redundant circuits to reduce the impact of single or multiple circuit failure
- Our Products are designed and manufactured for use under standard conditions and not under any special or extraordinary environments or conditions, as exemplified below. Accordingly, ROHM shall not be in any way responsible or liable for any damages, expenses or losses arising from the use of any ROHM's Products under any special or extraordinary environments or conditions. If you intend to use our Products under any special or extraordinary environments or conditions (as exemplified below), your independent verification and confirmation of product performance, reliability, etc. prior to use, must be necessary:
  - Use of our Products in any types of liquid, including water, oils, chemicals, and organic solvents
  - Use of our Products outdoors or in places where the Products are exposed to direct sunlight or dust
  - Use of our Products in places where the Products are exposed to sea wind or corrosive gases, including Cl<sub>2</sub>, H<sub>2</sub>S, NH<sub>3</sub>, SO<sub>2</sub>, and NO<sub>2</sub>
  - Use of our Products in places where the Products are exposed to static electricity or electromagnetic waves
  - Use of our Products in proximity to heat-producing components, plastic cords, or other flammable items
  - Sealing or coating our Products with resin or other coating materials
  - Use of our Products without cleaning residue of flux (even if you use no-clean type fluxes, cleaning residue of flux is recommended); or Washing our Products by using water or water-soluble cleaning agents for cleaning residue after soldering
  - Use of the Products in places subject to dew condensation
- The Products are not subject to radiation-proof design.
- Please verify and confirm characteristics of the final or mounted products in using the Products.
- In particular, if a transient load (a large amount of load applied in a short period of time, such as pulse. is applied, confirmation of performance characteristics after on-board mounting is strongly recommended. Avoid applying power exceeding normal rated power; exceeding the power rating under steady-state loading condition may negatively affect product performance and reliability.
- De-rate Power Dissipation (Pd) depending on Ambient temperature (Ta). When used in sealed area, confirm the actual ambient temperature.
- Confirm that operation temperature is within the specified range described in the product specification.
- ROHM shall not be in any way responsible or liable for failure induced under deviant condition from what is defined in this document.

## Precaution for Mounting / Circuit board design

- When a highly active halogenous (chlorine, bromine, etc.) flux is used, the residue of flux may negatively affect product performance and reliability.
- In principle, the reflow soldering method must be used; if flow soldering method is preferred, please consult with the ROHM representative in advance.

For details, please refer to ROHM Mounting specification

### Precautions Regarding Application Examples and External Circuits

1. If change is made to the constant of an external circuit, please allow a sufficient margin considering variations of the characteristics of the Products and external components, including transient characteristics, as well as static characteristics.
2. You agree that application notes, reference designs, and associated data and information contained in this document are presented only as guidance for Products use. Therefore, in case you use such information, you are solely responsible for it and you must exercise your own independent verification and judgment in the use of such information contained in this document. ROHM shall not be in any way responsible or liable for any damages, expenses or losses incurred by you or third parties arising from the use of such information.

### Precaution for Electrostatic

This Product is electrostatic sensitive product, which may be damaged due to electrostatic discharge. Please take proper caution in your manufacturing process and storage so that voltage exceeding the Products maximum rating will not be applied to Products. Please take special care under dry condition (e.g. Grounding of human body / equipment / solder iron, isolation from charged objects, setting of Ionizer, friction prevention and temperature / humidity control).

### Precaution for Storage / Transportation

1. Product performance and soldered connections may deteriorate if the Products are stored in the places where:
  - [a] the Products are exposed to sea winds or corrosive gases, including Cl<sub>2</sub>, H<sub>2</sub>S, NH<sub>3</sub>, SO<sub>2</sub>, and NO<sub>2</sub>
  - [b] the temperature or humidity exceeds those recommended by ROHM
  - [c] the Products are exposed to direct sunshine or condensation
  - [d] the Products are exposed to high Electrostatic
2. Even under ROHM recommended storage condition, solderability of products out of recommended storage time period may be degraded. It is strongly recommended to confirm solderability before using Products of which storage time is exceeding the recommended storage time period.
3. Store / transport cartons in the correct direction, which is indicated on a carton with a symbol. Otherwise bent leads may occur due to excessive stress applied when dropping of a carton.
4. Use Products within the specified time after opening a humidity barrier bag. Baking is required before using Products of which storage time is exceeding the recommended storage time period.

### Precaution for Product Label

QR code printed on ROHM Products label is for ROHM's internal use only.

### Precaution for Disposition

When disposing Products please dispose them properly using an authorized industry waste company.

### Precaution for Foreign Exchange and Foreign Trade act

Since our Products might fall under controlled goods prescribed by the applicable foreign exchange and foreign trade act, please consult with ROHM representative in case of export.

### Precaution Regarding Intellectual Property Rights

1. All information and data including but not limited to application example contained in this document is for reference only. ROHM does not warrant that foregoing information or data will not infringe any intellectual property rights or any other rights of any third party regarding such information or data. ROHM shall not be in any way responsible or liable for infringement of any intellectual property rights or other damages arising from use of such information or data.:
2. No license, expressly or implied, is granted hereby under any intellectual property rights or other rights of ROHM or any third parties with respect to the information contained in this document.

### Other Precaution

1. This document may not be reprinted or reproduced, in whole or in part, without prior written consent of ROHM.
2. The Products may not be disassembled, converted, modified, reproduced or otherwise changed without prior written consent of ROHM.
3. In no event shall you use in any way whatsoever the Products and the related technical information contained in the Products or this document for any military purposes, including but not limited to, the development of mass-destruction weapons.
4. The proper names of companies or products described in this document are trademarks or registered trademarks of ROHM, its affiliated companies or third parties.

**General Precaution**

1. Before you use our Products, you are requested to carefully read this document and fully understand its contents. ROHM shall not be in any way responsible or liable for failure, malfunction or accident arising from the use of any ROHM's Products against warning, caution or note contained in this document.
2. All information contained in this document is current as of the issuing date and subject to change without any prior notice. Before purchasing or using ROHM's Products, please confirm the latest information with a ROHM sales representative.
3. The information contained in this document is provided on an "as is" basis and ROHM does not warrant that all information contained in this document is accurate and/or error-free. ROHM shall not be in any way responsible or liable for any damages, expenses or losses incurred by you or third parties resulting from inaccuracy or errors of or concerning such information.

Компания «Life Electronics» занимается поставками электронных компонентов импортного и отечественного производства от производителей и со складов крупных дистрибьюторов Европы, Америки и Азии.

С конца 2013 года компания активно расширяет линейку поставок компонентов по направлению коаксиальный кабель, кварцевые генераторы и конденсаторы (керамические, пленочные, электролитические), за счёт заключения дистрибьюторских договоров

Мы предлагаем:

- Конкурентоспособные цены и скидки постоянным клиентам.
- Специальные условия для постоянных клиентов.
- Подбор аналогов.
- Поставку компонентов в любых объемах, удовлетворяющих вашим потребностям.
- Приемлемые сроки поставки, возможна ускоренная поставка.
- Доставку товара в любую точку России и стран СНГ.
- Комплексную поставку.
- Работу по проектам и поставку образцов.
- Формирование склада под заказчика.
- Сертификаты соответствия на поставляемую продукцию (по желанию клиента).
- Тестирование поставляемой продукции.
- Поставку компонентов, требующих военную и космическую приемку.
- Входной контроль качества.
- Наличие сертификата ISO.

В составе нашей компании организован Конструкторский отдел, призванный помогать разработчикам, и инженерам.

Конструкторский отдел помогает осуществить:

- Регистрацию проекта у производителя компонентов.
- Техническую поддержку проекта.
- Защиту от снятия компонента с производства.
- Оценку стоимости проекта по компонентам.
- Изготовление тестовой платы монтаж и пусконаладочные работы.



Тел: +7 (812) 336 43 04 (многоканальный)

Email: [org@lifeelectronics.ru](mailto:org@lifeelectronics.ru)