



**MICROCHIP**

---

**RE46C190  
Demo Board  
User's Guide**

---

**Note the following details of the code protection feature on Microchip devices:**

- Microchip products meet the specification contained in their particular Microchip Data Sheet.
- Microchip believes that its family of products is one of the most secure families of its kind on the market today, when used in the intended manner and under normal conditions.
- There are dishonest and possibly illegal methods used to breach the code protection feature. All of these methods, to our knowledge, require using the Microchip products in a manner outside the operating specifications contained in Microchip's Data Sheets. Most likely, the person doing so is engaged in theft of intellectual property.
- Microchip is willing to work with the customer who is concerned about the integrity of their code.
- Neither Microchip nor any other semiconductor manufacturer can guarantee the security of their code. Code protection does not mean that we are guaranteeing the product as "unbreakable."

Code protection is constantly evolving. We at Microchip are committed to continuously improving the code protection features of our products. Attempts to break Microchip's code protection feature may be a violation of the Digital Millennium Copyright Act. If such acts allow unauthorized access to your software or other copyrighted work, you may have a right to sue for relief under that Act.

---

Information contained in this publication regarding device applications and the like is provided only for your convenience and may be superseded by updates. It is your responsibility to ensure that your application meets with your specifications. MICROCHIP MAKES NO REPRESENTATIONS OR WARRANTIES OF ANY KIND WHETHER EXPRESS OR IMPLIED, WRITTEN OR ORAL, STATUTORY OR OTHERWISE, RELATED TO THE INFORMATION, INCLUDING BUT NOT LIMITED TO ITS CONDITION, QUALITY, PERFORMANCE, MERCHANTABILITY OR FITNESS FOR PURPOSE. Microchip disclaims all liability arising from this information and its use. Use of Microchip devices in life support and/or safety applications is entirely at the buyer's risk, and the buyer agrees to defend, indemnify and hold harmless Microchip from any and all damages, claims, suits, or expenses resulting from such use. No licenses are conveyed, implicitly or otherwise, under any Microchip intellectual property rights.

**Trademarks**

The Microchip name and logo, the Microchip logo, dsPIC, KEELOQ, KEELOQ logo, MPLAB, PIC, PICmicro, PICSTART, PIC<sup>32</sup> logo, rPIC and UNI/O are registered trademarks of Microchip Technology Incorporated in the U.S.A. and other countries.

FilterLab, Hampshire, HI-TECH C, Linear Active Thermistor, MXDEV, MXLAB, SEEVAL and The Embedded Control Solutions Company are registered trademarks of Microchip Technology Incorporated in the U.S.A.

Analog-for-the-Digital Age, Application Maestro, CodeGuard, dsPICDEM, dsPICDEM.net, dsPICworks, dsSPEAK, ECAN, ECONOMONITOR, FanSense, HI-TIDE, In-Circuit Serial Programming, ICSP, Mindi, MiWi, MPASM, MPLAB Certified logo, MPLIB, MPLINK, mTouch, Omniscient Code Generation, PICC, PICC-18, PICDEM, PICDEM.net, PICKit, PICtail, REAL ICE, rLAB, Select Mode, Total Endurance, TSHARC, UniWinDriver, WiperLock and ZENA are trademarks of Microchip Technology Incorporated in the U.S.A. and other countries.

SQTP is a service mark of Microchip Technology Incorporated in the U.S.A.

All other trademarks mentioned herein are property of their respective companies.

© 2011, Microchip Technology Incorporated, Printed in the U.S.A., All Rights Reserved.

 Printed on recycled paper.

ISBN: 978-1-61341-089-9

*Microchip received ISO/TS-16949:2002 certification for its worldwide headquarters, design and wafer fabrication facilities in Chandler and Tempe, Arizona; Gresham, Oregon and design centers in California and India. The Company's quality system processes and procedures are for its PIC<sup>®</sup> MCUs and dsPIC<sup>®</sup> DSCs, KEELOQ<sup>®</sup> code hopping devices, Serial EEPROMs, microperipherals, nonvolatile memory and analog products. In addition, Microchip's quality system for the design and manufacture of development systems is ISO 9001:2000 certified.*

**QUALITY MANAGEMENT SYSTEM  
CERTIFIED BY DNV  
== ISO/TS 16949:2002 ==**

## Table of Contents

<b>Preface</b> .....	<b>5</b>
Introduction.....	5
Document Layout .....	5
Conventions Used in this Guide .....	6
Recommended Reading.....	7
The Microchip Web Site .....	7
Customer Support .....	7
Document Revision History .....	8
 <b>Chapter 1. Product Overview</b>	
1.1 Introduction .....	9
1.2 What is the RE46C190 Demo Board? .....	9
1.3 What the RE46C190 Demo Board Kit Contains .....	10
 <b>Chapter 2. Installation and Operation</b>	
2.1 Introduction .....	11
2.2 Setup .....	12
2.3 Getting Started .....	12
2.4 Modifying the Demo Board .....	14
 <b>Appendix A. Schematic and Layouts</b>	
A.1 Introduction .....	15
A.2 Board Schematic - RE46C190 Application Circuit and Smoke Chamber Regulator .....	16
A.3 Smoke Chamber Emulation Circuit .....	17
A.4 Board - Top Silk and Pads .....	17
A.5 Board - Top Trace and Pads .....	18
A.6 Board - Bottom Trace and Pads .....	18
 <b>Appendix B. Bill of Materials (BOM)</b>	
<b>Worldwide Sales and Service</b> .....	<b>21</b>

# RE46C190 Demo Board User's Guide

---

---

---

---

## Preface

---

---

### NOTICE TO CUSTOMERS

All documentation becomes dated, and this manual is no exception. Microchip tools and documentation are constantly evolving to meet customer needs, so some actual dialogs and/or tool descriptions may differ from those in this document. Please refer to our web site ([www.microchip.com](http://www.microchip.com)) to obtain the latest documentation available.

Documents are identified with a “DS” number. This number is located on the bottom of each page, in front of the page number. The numbering convention for the DS number is “DSXXXXA”, where “XXXX” is the document number and “A” is the revision level of the document.

For the most up-to-date information on development tools, see the MPLAB® IDE on-line help. Select the Help menu, and then Topics to open a list of available on-line help files.

## INTRODUCTION

This chapter contains general information that will be useful to know before using the RE46C190 Demo Board. Items discussed in this chapter include:

- Document Layout
- Conventions Used in this Guide
- Recommended Reading
- The Microchip Web Site
- Customer Support
- Document Revision History

## DOCUMENT LAYOUT

This document describes how to use the RE46C190 Demo Board as a development tool to emulate and debug firmware on a target board. The manual layout is as follows:

- **Chapter 1. “Product Overview”** – This chapter introduces the main characteristics of the RE46C190 Demo Board.
- **Chapter 2. “Installation and Operation”** – Includes a detailed description of the board and instructions on how to get started.
- **Appendix A. “Schematic and Layouts”** – Shows the schematic and layout diagrams.
- **Appendix B. “Bill of Materials (BOM)”** – Lists the parts used to build the RE46C190 Demo Board.

# RE46C190 Demo Board User's Guide

## CONVENTIONS USED IN THIS GUIDE

This manual uses the following documentation conventions:

### DOCUMENTATION CONVENTIONS

Description	Represents	Examples
<b>Arial font:</b>		
Italic characters	Referenced books	<i>MPLAB<sup>®</sup> IDE User's Guide</i>
	Emphasized text	...is the <i>only</i> compiler...
Initial caps	A window	the Output window
	A dialog	the Settings dialog
	A menu selection	select Enable Programmer
Quotes	A field name in a window or dialog	"Save project before build"
Underlined, italic text with right angle bracket	A menu path	<u><i>File&gt;Save</i></u>
Bold characters	A dialog button	Click <b>OK</b>
	A tab	Click the <b>Power</b> tab
N'Rnnnn	A number in verilog format, where N is the total number of digits, R is the radix and n is a digit.	4'b0010, 2'hF1
Text in angle brackets < >	A key on the keyboard	Press <Enter>, <F1>
<b>Courier New font:</b>		
Plain Courier New	Sample source code	#define START
	Filenames	autoexec.bat
	File paths	c:\mcc18\h
	Keywords	_asm, _endasm, static
	Command-line options	-Opa+, -Opa-
	Bit values	0, 1
	Constants	0xFF, 'A'
Italic Courier New	A variable argument	<i>file.o</i> , where <i>file</i> can be any valid filename
Square brackets [ ]	Optional arguments	mcc18 [options] <i>file</i> [options]
Curly brackets and pipe character: {   }	Choice of mutually exclusive arguments; an OR selection	errorlevel {0 1}
Ellipses...	Replaces repeated text	var_name [, var_name...]
	Represents code supplied by user	void main (void) { ... }

## RECOMMENDED READING

This user's guide describes how to use the RE46C190 Demo Board. Other useful documents are listed below. The following Microchip documents are available and recommended as supplemental reference resources.

- **RE46C190 Data Sheet - “CMOS Low Voltage Photoelectric Smoke Detector ASIC with Interconnect and Timer Mode”, DS22271.**

## THE MICROCHIP WEB SITE

Microchip provides online support via our web site at [www.microchip.com](http://www.microchip.com). This web site is used as a means to make files and information easily available to customers. Accessible by using your favorite Internet browser, the web site contains the following information:

- **Product Support** – Data sheets and errata, application notes and sample programs, design resources, user's guides and hardware support documents, latest software releases and archived software
- **General Technical Support** – Frequently Asked Questions (FAQs), technical support requests, online discussion groups, Microchip consultant program member listing
- **Business of Microchip** – Product selector and ordering guides, latest Microchip press releases, listing of seminars and events, listings of Microchip sales offices, distributors and factory representatives

## CUSTOMER SUPPORT

Users of Microchip products can receive assistance through several channels:

- Distributor or Representative
- Local Sales Office
- Field Application Engineer (FAE)
- Technical Support

Customers should contact their distributor, representative or field application engineer (FAE) for support. Local sales offices are also available to help customers. A listing of sales offices and locations is included in the back of this document.

Technical support is available through the web site at:  
<http://www.microchip.com/support>

# RE46C190 Demo Board User's Guide

---

## DOCUMENT REVISION HISTORY

### Revision A (April 2011)

- Initial Release of this Document.



## Chapter 1. Product Overview

### 1.1 INTRODUCTION

The RE46C190 is a low voltage, programmable photo smoke detector with interconnect, local alarm indication, programmable setup, programmable calibration, programmable feature selection, boost regulator and horn driver. This device has a minimal external component count.

This chapter provides an overview of the RE46C190 Demo Board and covers the following topics:

- What is the RE46C190 Demo Board?
- What the RE46C190 Demo Board Kit Contains

### 1.2 WHAT IS THE RE46C190 DEMO BOARD?

The RE46C190 Demo Board is a complete stand-alone smoke detector application with a smoke chamber emulator. The demo board allows the evaluation of all the functions that the RE46C190 device has. Key test points of the device are available at the bottom edge of the demo board.

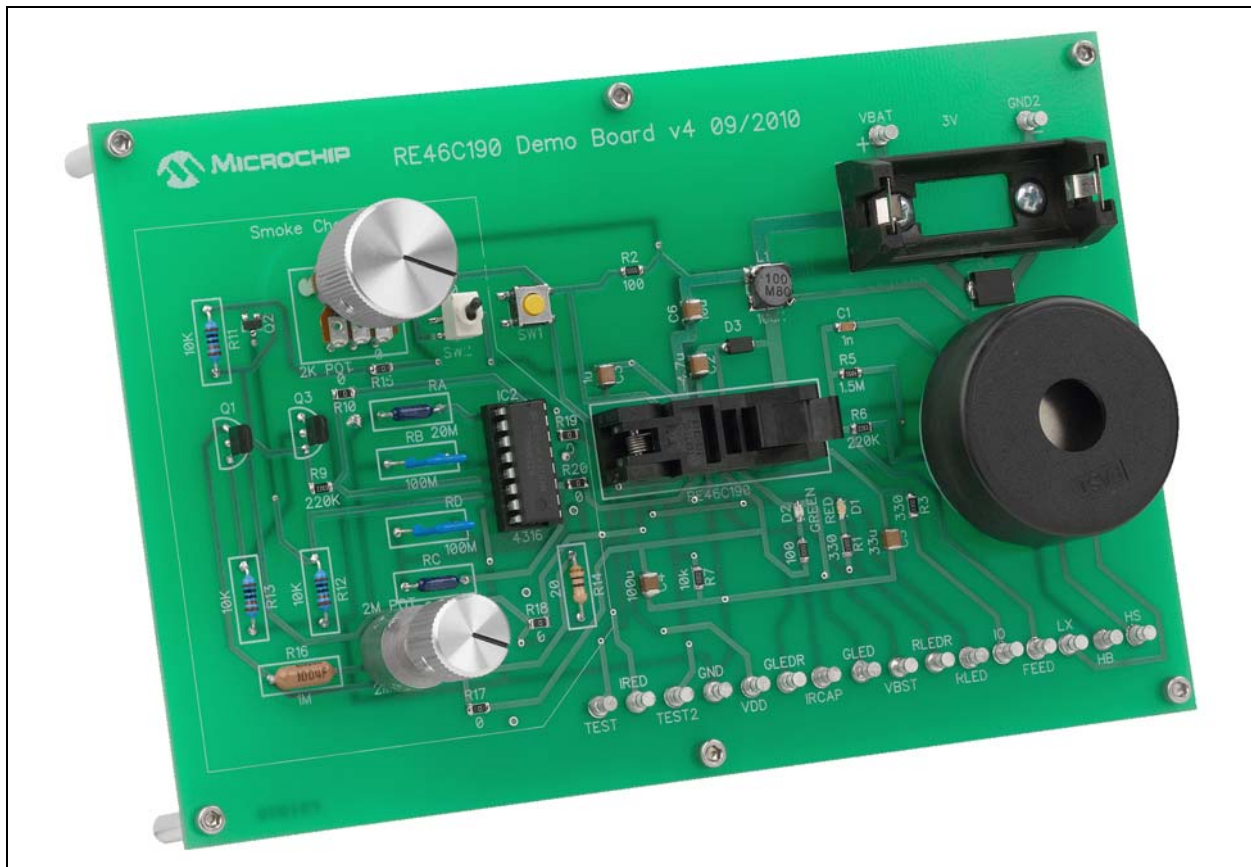

**FIGURE 1-1: RE46C190 Demo Board.**

# RE46C190 Demo Board User's Guide

---

The demo board is designed for battery operation using a CR123A battery, or can be operated using a power supply.

The RE46C190 application circuit is on the right side of the board by the battery holder and piezo horn, while the smoke chamber emulator is on the left side. The emulator can be disconnected from the application circuit and a photo smoke chamber or its components can be connected to the demo board.

## 1.3 WHAT THE RE46C190 DEMO BOARD KIT CONTAINS

The RE46C190 Demo Board kit includes:

- RE46C190 Demo Board (102-00344)
- Pre-programmed RE46C190 parts
- Knob and standoffs for final board assembly
- Important Information Sheet

## Chapter 2. Installation and Operation

### 2.1 INTRODUCTION

The RE46C190 Demo Board allows full evaluation of the RE46C190 functionality, including programmability. The demo board consists of two parts:

- RE46C190 application circuit (see Figure 2-1)
- A smoke-chamber emulation circuit (see Figure 2.2).

The smoke-chamber emulation circuit can be disconnected from the RE46C190 application circuit so the actual photo smoke chamber components can be evaluated in the RE46C190 application circuit. The board can be operated from a CR123A battery, or be powered from a 3V power supply.

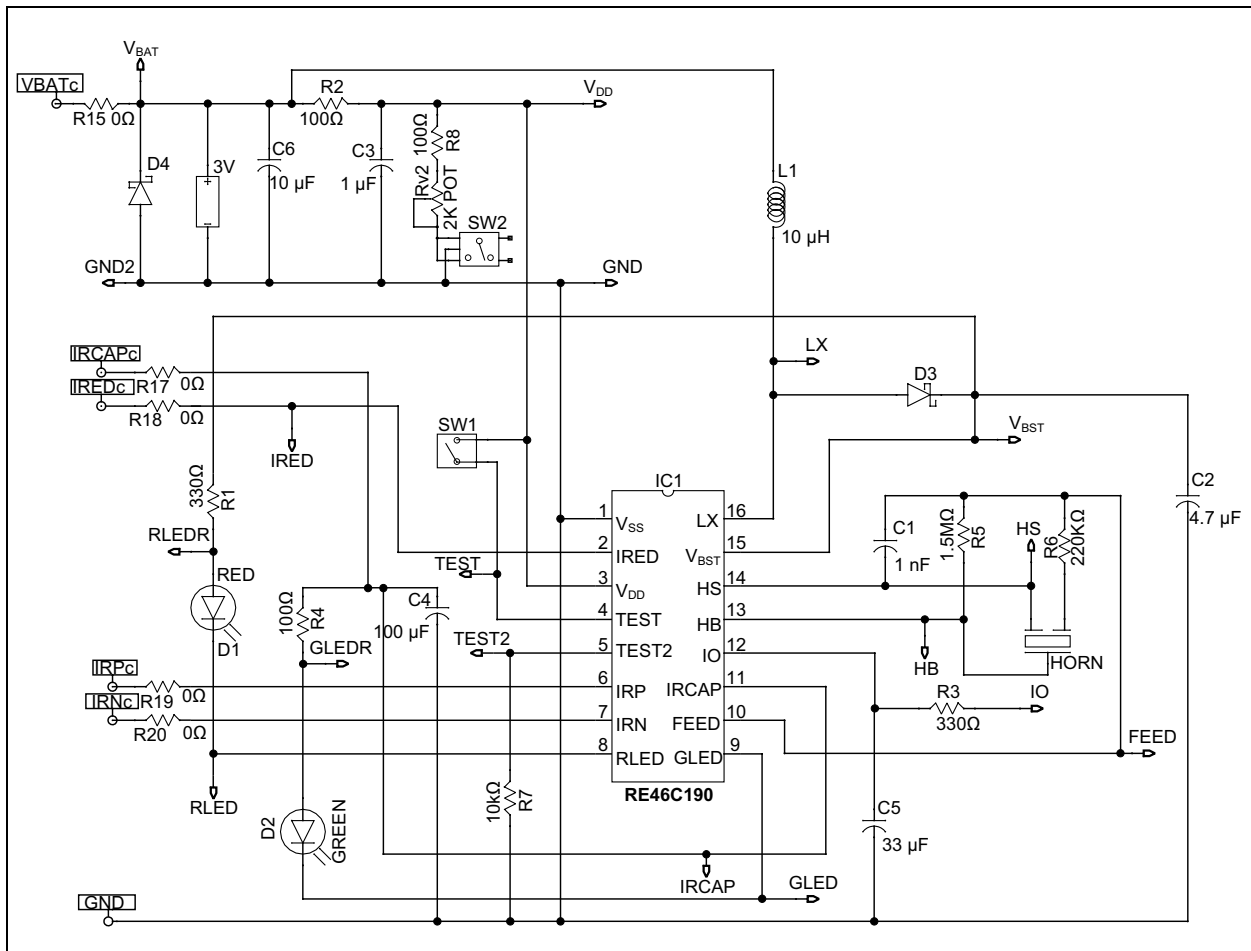

**FIGURE 2-1:** RE46C190 Application Circuit.

# RE46C190 Demo Board User's Guide

---

## 2.2 SETUP

Before powering the RE46C190 Demo Board, complete the following steps:

1. Place the potentiometer knob on the 2M POT.
2. Attach the six standoffs with screws are provided to act as legs for the demo board.
3. Start with the switch in OFF state, toggled toward the label R8, and ensure that Rv2 is turned fully clockwise, to its highest resistance value. The switch (SW2) and the potentiometer (Rv2) allow the apparent battery voltage ( $V_{DD}$ ) to be lowered so the low battery operation of the application can be evaluated.
4. Ensure that the 2M POT, used to set the current in the smoke chamber emulator, is turned fully counterclockwise to set a minimum photodiode current.
5. Ensure there is a preprogrammed RE46C190 in the ZIF socket. The socket's pin 1 designator is located near capacitor C2.
6. Insert a CR123A battery in the battery holder, or connect a 3V power supply to the terminals next to the battery holder (VBAT and GND2).

The RE46C190 Demo Board allows two adjustments when evaluating the RE46C190 device. The first adjustment uses the 2M POT to increase the current to the photodiode inputs IRN and IRP to simulate a smoke condition, by turning the potentiometer knob in a clockwise direction.

### WARNING

**The smoke emulator circuit is sensitive to the battery voltage or power supply voltage. To ensure consistent results from the smoke emulator, be sure the VBAT voltage is the same as used in the previous tests.**

When switch SW2 is toggled toward the center of the board, Rv2 is able to reduce the apparent battery voltage ( $V_{DD}$ ) supplied to the IC, when turned counterclockwise.

If a power supply is being used in place of a battery, be sure the current limit is set for a value greater than 2A. When the boost regulator is operating, it can draw peak currents greater than 1.0A. A low current limit may cause the power supply voltage to drop, and may reset the IC. This can appear as a non-specified operation.

Due to the sampling rate of the IC, the potentiometer adjustments do not have an immediate effect. Refer to the RE46C190 Data Sheet for specific information on timing.

## 2.3 GETTING STARTED

To emulate the basic smoke detect operation, slowly turn the 2M POT clockwise, until RLED flashes and the piezo horn sounds. This is the Alarm mode. A piece of tape over the hole in the piezo horn case reduces the volume of the horn during testing. Turn the 2M POT counterclockwise until the Alarm mode ends. This is the Hysteresis mode of operation. The GLED flashes to indicate a local alarm, i.e. this particular device has been in an alarm condition. Press SW1, the Push-to-Test button. The piezo horn will chirp as an audible indication that the Local Alarm Memory is set. When the button is released, the Local Alarm Memory is reset to Normal operation. Refer to the RE46C190 Data Sheet for specific details on device operation in Normal mode.

Repeat the test above, but leave the IC in Alarm mode, and press SW1 to enter the Hush mode. Continue by turning the 2M POT clockwise to re-enter the Alarm mode. Refer to the RE46C190 Data Sheet for Push-to-Test and Reduced Sensitivity operation.

# Installation and Operation

Another basic test is the low battery test. Connect a digital multimeter to the test pins  $V_{DD}$  and GND, to monitor the  $V_{DD}$ . Toggle the switch SW2 toward the center of the demo board and observe the change in  $V_{DD}$ . Turn Rv2 counterclockwise to lower the  $V_{DD}$  voltage to less than 2.4V, where the low battery threshold should be set. The piezo horn chirps once every 43 seconds. The low battery Silence mode can be entered by pressing SW1. Refer to the RE46C190 Data Sheet for details on the Supervisory mode.

The chamber test can be evaluated by first toggling the switch SW2 toward the label R8 and then turning the 2M POT fully counterclockwise. This places the demo board in a Non-Alarm state. Short the test point IRED to the test point IRCAP. This disables the smoke chamber emulator and causes the IC to fail the chamber test. Three chirps are heard after the test fails. Refer to the RE46C190 Data Sheet for details on this Supervisory mode.

Table 2-1 lists the program settings for the RE46C190 samples included with the demo board. Due to limitations of the smoke emulator, the IRED current, the photo amplifier gain and the integration time should not be changed.

**TABLE 2-1: PRE-PROGRAMMED RE46C190 SAMPLE**

Parameter	Setting
Long Term Drift Limit	0
Chamber Test Limit	2
Hush Limit	20
Hysteresis Limit	15
Normal Smoke Limit	20
Photo Amplifier Gain Factor	1
Integration Time	100 $\mu$ s
Low Battery Trip Limit	2.4V
Long Term Drift Enable	Disable
Low Battery Hush Enable	Enable
IRED Current	150 mA
Hush Option	Never Cancel
End Of Life Enable	Disabled
Tone Select	Temporal

Table 2-2 is a list of the test points easily available on the bottom of the demo board. Refer to **A.2 “Board Schematic - RE46C190 Application Circuit and Smoke Chamber Regulator”** for details of the connection of the test point. When using the test points, use an oscilloscope to observe RE46C190’s operation.

# RE46C190 Demo Board User's Guide

TABLE 2-2: RE46C190 DEMO BOARD TEST POINTS

Test Point	Description
V <sub>BAT</sub>	The battery voltage or power supply voltage
GND2	Second connection to V <sub>SS</sub>
TEST	Connection to Pin 4 of the RE46C190 device and the push-to-test button
IREDR	Connection to the smoke chamber emulator and to Pin 2 of the RE46C190 device
TEST2	Connection to Pin 5 of the RE46C190 device
GND	Connection to V <sub>SS</sub>
V <sub>DD</sub>	Connection to Pin 3 of the RE46C190 device
GLEDR	Connection to the green LED resistor and the green LED anode
IRCAP	Connection to the smoke chamber emulator and to Pin 11 of the RE46C190 device
GLED	Connection to the cathode of the green LED and to Pin 9 of the RE46C190 device
V <sub>BST</sub>	Connection to Pin 15 of the RE46C190 device
RLEDR	Connection to the red LED resistor and the red LED anode
RLED	Connection to the red LED cathode and to Pin 8 of the RE46C190 device
IO	Connection to Pin 12 of the RE46C190 device
FEED	Connection to Pin 10 of the RE46C190 device
LX	Connection to Pin 16 of the RE46C190 device
HB	Connection to Pin 13 of the RE46C190 device
HS	Connection to Pin 14 of the RE46C190 device

## 2.4 MODIFYING THE DEMO BOARD

The RE46C190 Demo Board can be modified to include a smoke chamber, or smoke chamber components. Jumpers R19 and R20 can be removed to allow a photodiode to be connected to the IRP and IRN pins of the IC, respectively. R17 and R18 can be removed to allow an infrared LED to be connected to the IRCAP and IRED pins, respectively.

The removal of jumper R15 will disconnect the smoke chamber emulator from the VBAT line. This allows the measurement of the smoke detector application average input current. It is important that the toggle switch SW2 be placed in the OFF position for this measurement.

### WARNING

The input current measurement requires an ammeter setting that can handle the large current draw of the boost regulator, while resolving microamperes of current. The effective series resistance of the ammeter can affect the operation of the boost regulator.

An alternative method for this measurement is to place a 100  $\mu$ F capacitor between the terminal VBAT and GND2, and connect one end of a 100 $\Omega$  resistor to VBAT. Connect the ammeter to the other end of the resistor and then to the positive terminal of the power supply, or battery. Connect the negative terminal of the battery or power supply to the terminal GND2. This simple RC filter will smooth out the current peaks. The capacitor should have a low ESR to minimize the voltage ripple at the VBAT terminal.

---

---

## **Appendix A. Schematic and Layouts**

---

---

### **A.1 INTRODUCTION**

This appendix contains the following schematics and layouts for the RE46C190 Demo Board.

- **A.2 “Board Schematic - RE46C190 Application Circuit and Smoke Chamber Regulator”**
- **A.3 “Smoke Chamber Emulation Circuit”**
- **A.4 “Board - Top Silk and Pads”**
- **A.5 “Board - Top Trace and Pads”**
- **A.6 “Board - Bottom Trace and Pads”**





## A.3 SMOKE CHAMBER EMULATION CIRCUIT

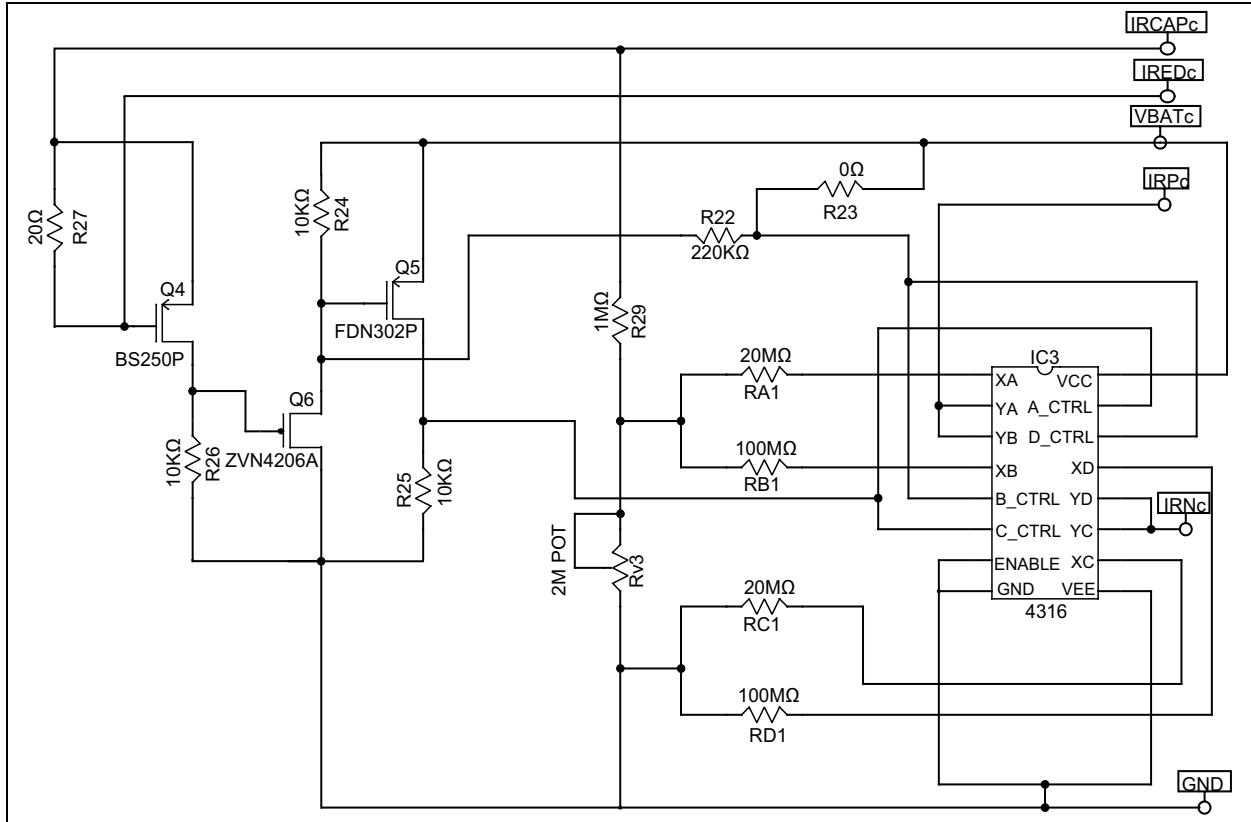

## A.4 BOARD - TOP SILK AND PADS

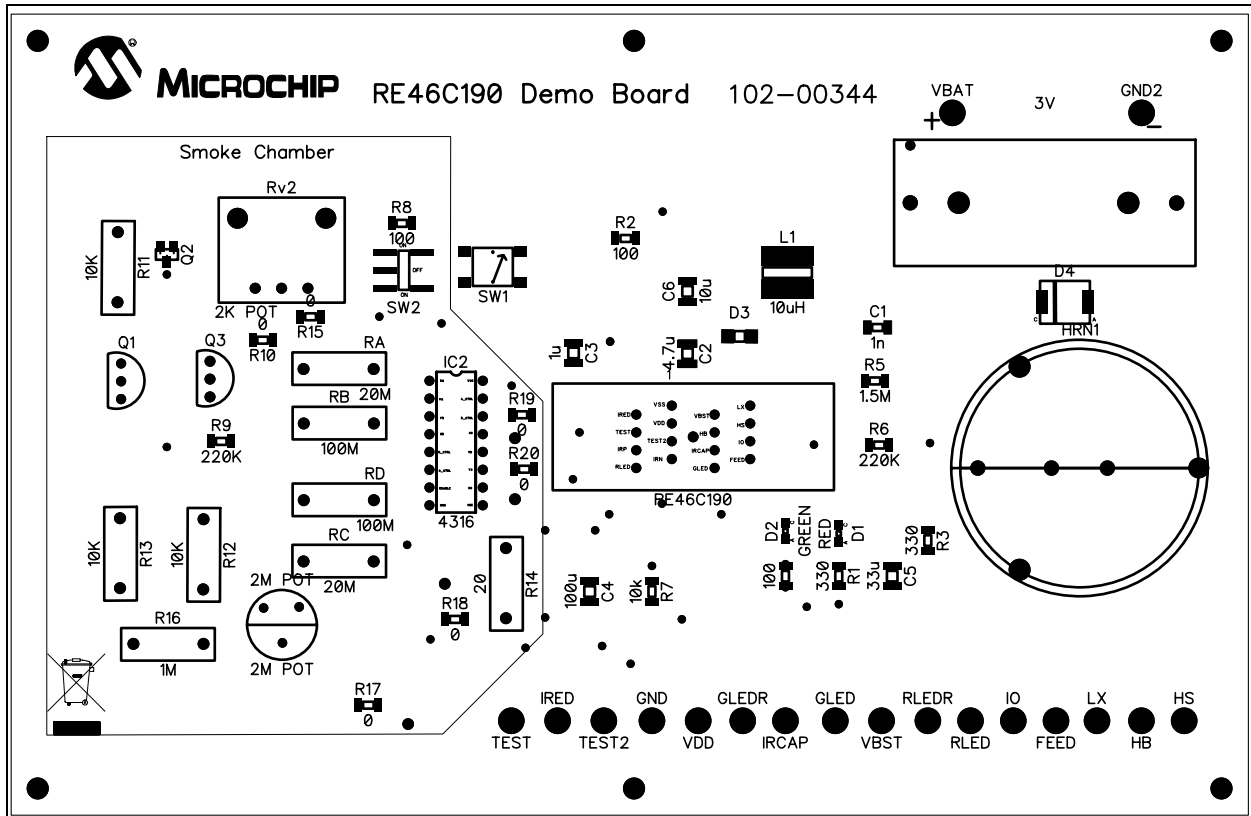

# RE46C190 Demo Board User's Guide

## A.5 BOARD - TOP TRACE AND PADS

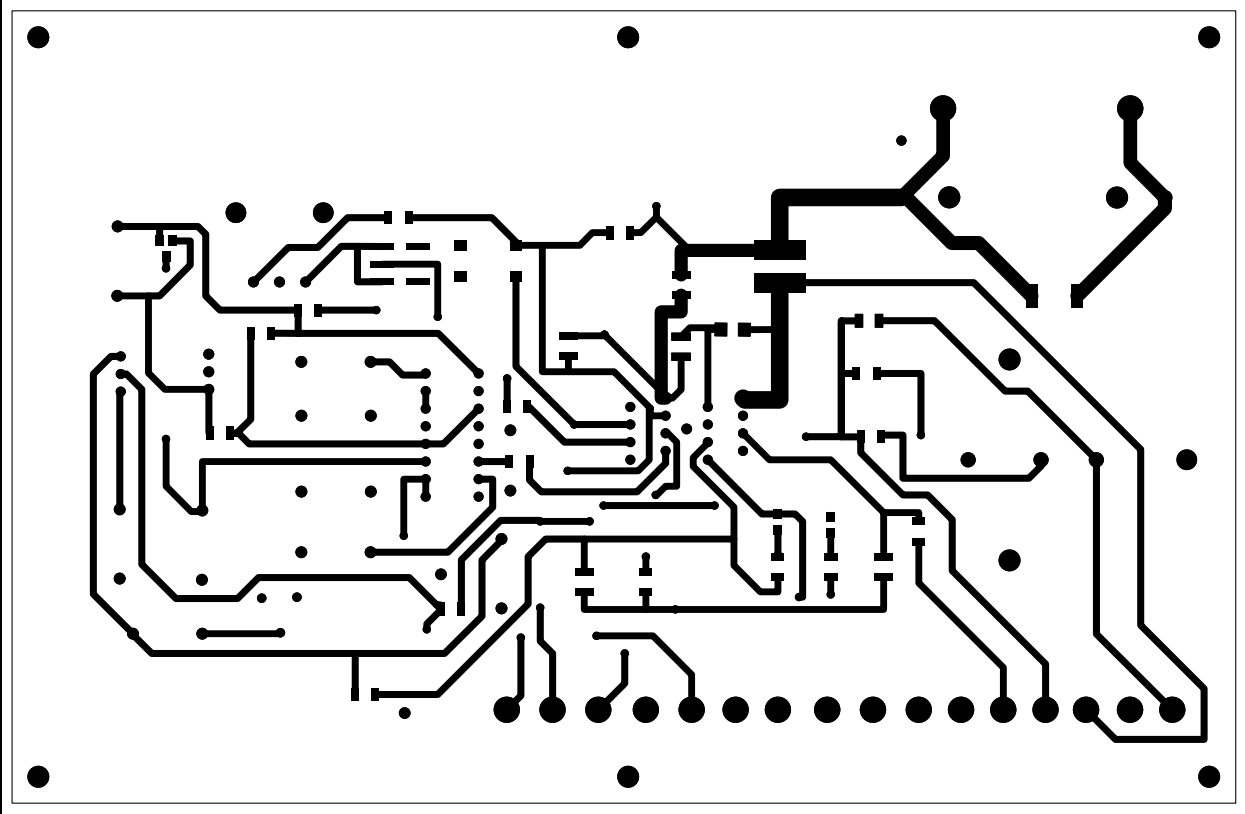

## A.6 BOARD - BOTTOM TRACE AND PADS

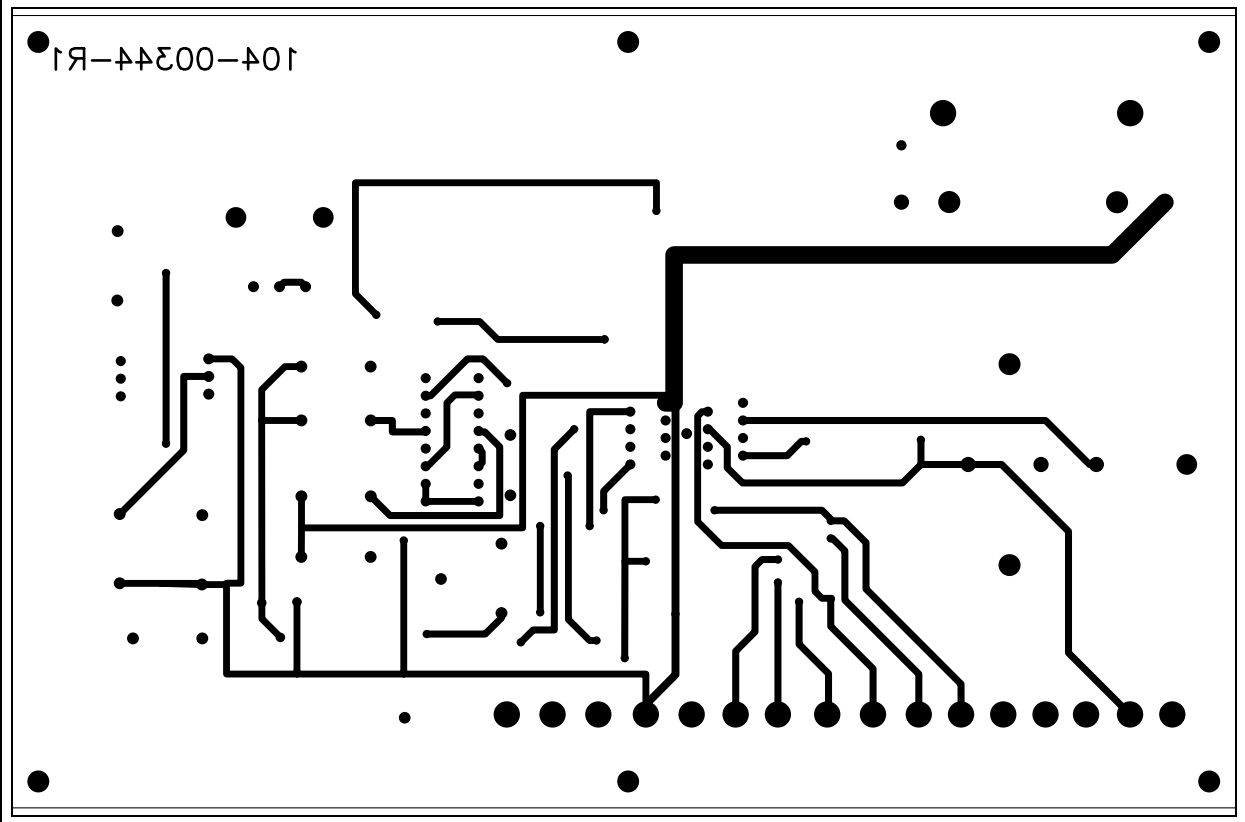

**Appendix B. Bill of Materials (BOM)**

**TABLE B-1: BILL OF MATERIALS (BOM)**

Qty	Reference	Description	Manufacturer	Part Number
3	BH1	CR123A Battery Holder for PCB mount - RoHS Compliant (BCR123A)	http://www.batteryspace.com	BCR123A
1	C1	Multilayer Ceramic Capacitor (MLCC) - 1206 100 volts 1000pF 10% X7R	Kemet® Electronics Corp.	C1206Y102K1RACTU
1	C2	Multilayer Ceramic Capacitor (MLCC) - SMD/SMT 1210 4.7uF 25volts X7R 20%	TDK® Corporation	C3225X7R1E475M
1	C3	Multilayer Ceramic Capacitor (MLCC) - 1210 100 volts 1uF 20% X7R	TDK Corporation	C3225X7R2A105M
1	C4	Multilayer Ceramic Capacitor (MLCC) - SMD/SMT 1210 100uF 6.3 volts X5R 20%	TDK Corporation	C3225X5R0J107M
1	C5	Multilayer Ceramic Capacitor (MLCC) - SMD/SMT 1210 33uF 6.3volts X5R 20%	TDK Corporation	C3225X5R0J336M
1	C6	Multilayer Ceramic Capacitor (MLCC) - SMD/SMT 1210 10uF 25volts X5R 10%	TDK Corporation	C3225X5R1E106K
1	D1	SMD Red 2.0V LEDs	Lumex® Inc.	SML-LXF0805SIC-TR
1	D2	SMD Green, 565nm 2.2V, 10mcd	Lumex Inc.	SML-LX0805GC-TR
1	D3	SCHOTTKY RECTIFIER, 1.5A, 25V, DO-214AC	Vishay® Intertechnology, Inc.	BYS10-25-E3/TR
1	D4	FAST SWITCH DIODE, 3A 600V DO-214AB	Vishay Intertechnology, Inc.	RS3J-E3/57T
1	HRN1	PCB mounting, Piezo Horn Sealed-type	MynTahl Corp.	EFM-290ED
1	IC1	SOIC SOCKET, 16POS, SMD Connector Type:SOIC Socket	3M	216-7383-55-1902
1	IC1	Microchip will Consign	Microchip Technology Inc.	<b>RE46C190S16F</b>
1	IC2	CONN IC SOCKET 16POS DIP TIN	Tyco® Electronics	2-641610-1
1	IC2 Socket	IC MUX/DEMUX QUAD 1X1 16DIP	ON Semiconductor®	MC74HC4316ANG
1	L1	Power Inductors 10uH 1.7A	Sumida Corporation	CDRH6D28NP-100NC
1	Q1	MOSFET P-CH 45V 230MA TO92-3	Diodes® Incorporated/Zetex	BS250P
1	Q2	MOSFET P-CH 20V 2.4A SSOT3	Fairchild Semiconductor®	FDN302P
1	Q3	MOSFET N-CH 60V 600MA TO92-3	Diodes Incorporated/Zetex	ZVN4206AV
1	PCB	RoHS Compliant Bare PCB, RE46C190 Demo Board	—	104-00344
6	R10, R15, R17, R18, R19, R20	Resistor 1206-SMD 0 ohm Jumper	Bourns® Inc.	CR1206-J/-000ELF
2	R1, R3	Resistors 1206-SMD 1/4 watt 330 ohms 1%	Vishay Intertechnology, Inc./Dale	CRCW1206330RFKTA

**Note 1:** The components listed in this Bill of Materials are representative of the PCB assembly. The released BOM used in manufacturing uses all RoHS-compliant components.

# RE46C190 Demo Board User's Guide

**TABLE B-1: BILL OF MATERIALS (BOM) (CONTINUED)**

Qty	Reference	Description	Manufacturer	Part Number
3	R2, R4, R8	Resistor 1206-SMD 1/4 watt 100 ohms 1%	Vishay Intertechnology, Inc./Dale	CRCW1206100RFKEA
1	R5	Resistors1206-SMD 1/4 watt 1.5 Meg ohms 1%	Vishay Intertechnology, Inc./Dale	CRCW12061M50FKEA
2	R6, R9	Resistors1206-SMD 1/4 watt 220K ohms 1%	Vishay Intertechnology, Inc./Dale	CRCW1206220KFKEA
1	R7	Resistors 1206-SMD 1/4 watt 10K ohms 1%	Vishay Intertechnology, Inc./Dale	CRCW120610K0FKEA
6	R10, R15, R17, R18, R19, R20	Resistor 1206-SMD 0 ohm Jumper	Bourns Inc.	CR1206-J-000ELF
3	R11, R12, R13	10KΩ Resistor	Vishay Intertechnology, Inc.	CCF0710K0GKE36
1	R14	RESISTOR, METAL FILM, 20OHM, 250mW, 1%	Multicomp	MCMF0W4FF200JA50
1	R16	RESISTOR, METAL FILM, 1MOHM, 500mW, 2%	Vishay Intertechnology, Inc.	CCF071M00GKE36
2	RA, RC	RESISTOR 20M OHM. 5W CARB COM	Ohmite® Mfg., Co.	OF206JE
2	RB, RD	RESISTOR, HV, 100MOHM, 800mW, 1%	Tyco Electronics	HBA100MFZRE
1	Rv1	POT 2.5MEG OHM CARBON 1/2W	Precision Electronic Components Ltd.	SPRU2551S28
1	Rv2	Potentiometer 2K LINEAR 12MM	Bourns Inc.	PDB12-H4251-202BF
1	SW1	SWITCH TACT 6MM 230GF H=4.3MM	OMRON Corporation	B3S-1002P
1	SW2	Toggle Switches SPDT ON-NONE-ON SMT	C&K Components	GT11MSCBE
18	Test Points	Circuit Board Hardware - PCB TERMINAL PIN TURRET	Harwin Plc.	H2121-01

**Note 1:** The components listed in this Bill of Materials are representative of the PCB assembly. The released BOM used in manufacturing uses all RoHS-compliant components.

**TABLE B-2: BILL OF MATERIALS - HARDWARE PARTS**

Qty	Reference	Description	Manufacturer	Part Number
2	Bat Holder Hex Nuts	NUT HEX 4-40 NYLON	B&F™ Fastener Supply	NY HN 440
2	Bat Holder Screws	SCREW MACH PHIL 4-40X3/8 NYLON	B&F Fastener Supply	NY PMS 440 0038 PH
1	POT Dials	SWITCH KNOB STRAIGHT .74" NATRL	Tyco Electronics	KLN700A1/4
1	POT Dials	SWITCH KNOB STRAIGHT .50" NATRL	Tyco Electronics	KLN500A1/8
6	Standoffs	SCREW MACH PHIL 4-40X1/4 NYLON	B&F Fastener Supply	NY PMS 440 0025 PH
6	Standoffs	STANDOFF HEX .500"L 4-40THR NYL	Keystone Electronics®	1902C

**Note 1:** The components listed in this Bill of Materials are representative of the PCB assembly. The released BOM used in manufacturing uses all RoHS-compliant components.



# MICROCHIP

## Worldwide Sales and Service

### AMERICAS

#### Corporate Office

2355 West Chandler Blvd.  
Chandler, AZ 85224-6199  
Tel: 480-792-7200  
Fax: 480-792-7277  
Technical Support:  
<http://www.microchip.com/support>  
Web Address:  
[www.microchip.com](http://www.microchip.com)

#### Atlanta

Duluth, GA  
Tel: 678-957-9614  
Fax: 678-957-1455

#### Boston

Westborough, MA  
Tel: 774-760-0087  
Fax: 774-760-0088

#### Chicago

Itasca, IL  
Tel: 630-285-0071  
Fax: 630-285-0075

#### Cleveland

Independence, OH  
Tel: 216-447-0464  
Fax: 216-447-0643

#### Dallas

Addison, TX  
Tel: 972-818-7423  
Fax: 972-818-2924

#### Detroit

Farmington Hills, MI  
Tel: 248-538-2250  
Fax: 248-538-2260

#### Indianapolis

Noblesville, IN  
Tel: 317-773-8323  
Fax: 317-773-5453

#### Los Angeles

Mission Viejo, CA  
Tel: 949-462-9523  
Fax: 949-462-9608

#### Santa Clara

Santa Clara, CA  
Tel: 408-961-6444  
Fax: 408-961-6445

#### Toronto

Mississauga, Ontario,  
Canada  
Tel: 905-673-0699  
Fax: 905-673-6509

### ASIA/PACIFIC

#### Asia Pacific Office

Suites 3707-14, 37th Floor  
Tower 6, The Gateway  
Harbour City, Kowloon  
Hong Kong  
Tel: 852-2401-1200  
Fax: 852-2401-3431

#### Australia - Sydney

Tel: 61-2-9868-6733  
Fax: 61-2-9868-6755

#### China - Beijing

Tel: 86-10-8528-2100  
Fax: 86-10-8528-2104

#### China - Chengdu

Tel: 86-28-8665-5511  
Fax: 86-28-8665-7889

#### China - Chongqing

Tel: 86-23-8980-9588  
Fax: 86-23-8980-9500

#### China - Hong Kong SAR

Tel: 852-2401-1200  
Fax: 852-2401-3431

#### China - Nanjing

Tel: 86-25-8473-2460  
Fax: 86-25-8473-2470

#### China - Qingdao

Tel: 86-532-8502-7355  
Fax: 86-532-8502-7205

#### China - Shanghai

Tel: 86-21-5407-5533  
Fax: 86-21-5407-5066

#### China - Shenyang

Tel: 86-24-2334-2829  
Fax: 86-24-2334-2393

#### China - Shenzhen

Tel: 86-755-8203-2660  
Fax: 86-755-8203-1760

#### China - Wuhan

Tel: 86-27-5980-5300  
Fax: 86-27-5980-5118

#### China - Xian

Tel: 86-29-8833-7252  
Fax: 86-29-8833-7256

#### China - Xiamen

Tel: 86-592-2388138  
Fax: 86-592-2388130

#### China - Zhuhai

Tel: 86-756-3210040  
Fax: 86-756-3210049

### ASIA/PACIFIC

#### India - Bangalore

Tel: 91-80-3090-4444  
Fax: 91-80-3090-4123

#### India - New Delhi

Tel: 91-11-4160-8631  
Fax: 91-11-4160-8632

#### India - Pune

Tel: 91-20-2566-1512  
Fax: 91-20-2566-1513

#### Japan - Yokohama

Tel: 81-45-471- 6166  
Fax: 81-45-471-6122

#### Korea - Daegu

Tel: 82-53-744-4301  
Fax: 82-53-744-4302

#### Korea - Seoul

Tel: 82-2-554-7200  
Fax: 82-2-558-5932 or  
82-2-558-5934

#### Malaysia - Kuala Lumpur

Tel: 60-3-6201-9857  
Fax: 60-3-6201-9859

#### Malaysia - Penang

Tel: 60-4-227-8870  
Fax: 60-4-227-4068

#### Philippines - Manila

Tel: 63-2-634-9065  
Fax: 63-2-634-9069

#### Singapore

Tel: 65-6334-8870  
Fax: 65-6334-8850

#### Taiwan - Hsin Chu

Tel: 886-3-6578-300  
Fax: 886-3-6578-370

#### Taiwan - Kaohsiung

Tel: 886-7-213-7830  
Fax: 886-7-330-9305

#### Taiwan - Taipei

Tel: 886-2-2500-6610  
Fax: 886-2-2508-0102

#### Thailand - Bangkok

Tel: 66-2-694-1351  
Fax: 66-2-694-1350

### EUROPE

#### Austria - Wels

Tel: 43-7242-2244-39  
Fax: 43-7242-2244-393

#### Denmark - Copenhagen

Tel: 45-4450-2828  
Fax: 45-4485-2829

#### France - Paris

Tel: 33-1-69-53-63-20  
Fax: 33-1-69-30-90-79

#### Germany - Munich

Tel: 49-89-627-144-0  
Fax: 49-89-627-144-44

#### Italy - Milan

Tel: 39-0331-742611  
Fax: 39-0331-466781

#### Netherlands - Drunen

Tel: 31-416-690399  
Fax: 31-416-690340

#### Spain - Madrid

Tel: 34-91-708-08-90  
Fax: 34-91-708-08-91

#### UK - Wokingham

Tel: 44-118-921-5869  
Fax: 44-118-921-5820

02/18/11

Компания «Life Electronics» занимается поставками электронных компонентов импортного и отечественного производства от производителей и со складов крупных дистрибьюторов Европы, Америки и Азии.

С конца 2013 года компания активно расширяет линейку поставок компонентов по направлению коаксиальный кабель, кварцевые генераторы и конденсаторы (керамические, пленочные, электролитические), за счёт заключения дистрибьюторских договоров

Мы предлагаем:

- Конкуренеспособные цены и скидки постоянным клиентам.
- Специальные условия для постоянных клиентов.
- Подбор аналогов.
- Поставку компонентов в любых объемах, удовлетворяющих вашим потребностям.
- Приемлемые сроки поставки, возможна ускоренная поставка.
- Доставку товара в любую точку России и стран СНГ.
- Комплексную поставку.
- Работу по проектам и поставку образцов.
- Формирование склада под заказчика.
- Сертификаты соответствия на поставляемую продукцию (по желанию клиента).
- Тестирование поставляемой продукции.
- Поставку компонентов, требующих военную и космическую приемку.
- Входной контроль качества.
- Наличие сертификата ISO.

В составе нашей компании организован Конструкторский отдел, призванный помогать разработчикам, и инженерам.

Конструкторский отдел помогает осуществить:

- Регистрацию проекта у производителя компонентов.
- Техническую поддержку проекта.
- Защиту от снятия компонента с производства.
- Оценку стоимости проекта по компонентам.
- Изготовление тестовой платы монтаж и пусконаладочные работы.



Тел: +7 (812) 336 43 04 (многоканальный)

Email: [org@lifeelectronics.ru](mailto:org@lifeelectronics.ru)