

NB7L1008

2.5V / 3.3V 1:8 LVPECL Fanout Buffer

Multi-Level Inputs w/ Internal Termination

Description

The NB7L1008 is a high performance differential 1:8 Clock/Data fanout buffer. The NB7L1008 produces eight identical output copies of Clock or Data operating up to 7 GHz or 12 Gb/s, respectively. As such, the NB7L1008 is ideal for SONET, GigE, Fiber Channel, Backplane and other Clock/Data distribution applications. The differential inputs incorporate internal 50 Ω termination resistors that are accessed through the VT pin. This feature allows the NB7L1008 to accept various logic standards, such as LVPECL, CML, LVDS logic levels. The V_{REFAC} reference output can be used to rebias capacitor-coupled differential or single-ended input signals. The 1:8 fanout design was optimized for low output skew applications. The NB7L1008 is a member of the GigaComm™ family of high performance clock products.

Features

- Typical Maximum Input Data Rate > 12 Gb/s Typical
- Data Dependent Jitter < 15 ps
- Maximum Input Clock Frequency > 7 GHz Typical
- Random Clock Jitter < 0.8 ps RMS
- Low Skew 1:8 LVPECL Outputs, < 20 ps max
- Multi-Level Inputs, accepts LVPECL, CML, LVDS
- 160 ps Typical Propagation Delay
- 50 ps Typical Rise and Fall Times
- Differential LVPECL Outputs, 750 mV Peak-to-Peak, Typical
- Operating Range: $V_{CC} = 2.375$ V to 3.6 V, GND = 0 V
- Internal Input Termination Resistors, 50 Ω
- V_{REFAC} Reference Output
- QFN-32 Package, 5 mm x 5 mm
- -40°C to +85°C Ambient Operating Temperature
- These are Pb-Free and Halide-Free Devices



ON Semiconductor®

<http://onsemi.com>

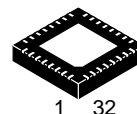

QFN32
MN SUFFIX
CASE 488AM

MARKING DIAGRAM

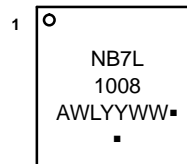

A = Assembly Location
WL = Wafer Lot
YY = Year
WW = Work Week
▪ = Pb-Free Package

(Note: Microdot may be in either location)

SIMPLIFIED LOGIC DIAGRAM

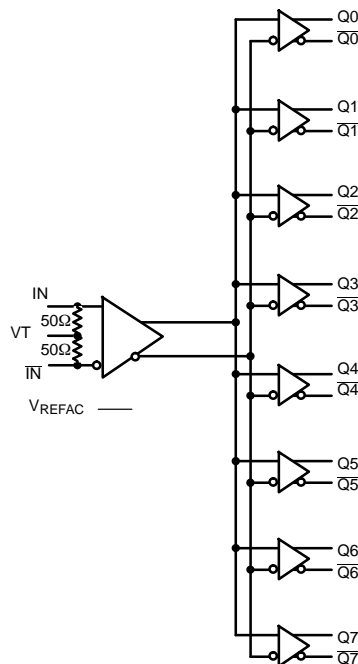

ORDERING INFORMATION

See detailed ordering and shipping information on page 9 of this data sheet.

NB7L1008

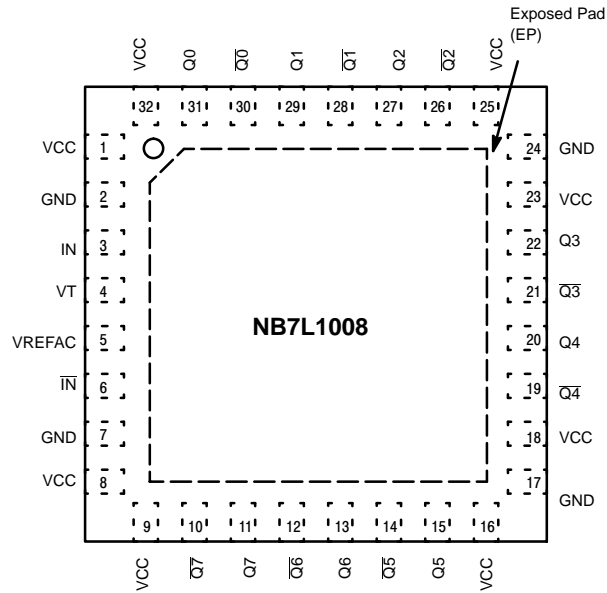

Figure 1. 32-Lead QFN Pinout (Top View)

Table 1. PIN DESCRIPTION

Pin	Name	I/O	Description
3, 6	IN, $\overline{\text{IN}}$	LVPECL, CML, LVDS Input	Non-inverted / Inverted Differential Clock/Data Input. Note 1
4	VT		Internal 50 Ω Termination Pin for IN and $\overline{\text{IN}}$
2, 7 17,24	GND		Negative Supply Voltage, Note 2
1, 8, 9, 16, 18, 23, 25, 32	V _{CC}		Positive Supply Voltage, Note 2
31, 30, 29, 28, 27, 26, 22, 21, 20, 19, 15, 14, 13, 12, 11, 10	Q0, $\overline{\text{Q0}}$, Q1, $\overline{\text{Q1}}$, Q2, $\overline{\text{Q2}}$, Q3, $\overline{\text{Q3}}$, Q4, $\overline{\text{Q4}}$, Q5, $\overline{\text{Q5}}$, Q6, $\overline{\text{Q6}}$, Q7, $\overline{\text{Q7}}$	LVPECL	Non-inverted / Inverted Differential Output.
5	VREFAC		Output Voltage Reference for Capacitor-Coupled Inputs, only
–	EP	–	The Exposed Pad (EP) on the QFN-32 package bottom is thermally connected to the die for improved heat transfer out of package. The exposed pad must be attached to a heat-sinking conduit. The pad is electrically connected to GND and is recommended to be electrically connected to GND on the PC board.

1. In the differential configuration when the input termination pin (V_T) is connected to a common termination voltage or left open, and if no signal is applied on IN/ $\overline{\text{IN}}$, then the device will be susceptible to self-oscillation.
2. All V_{CC} and GND pins must be externally connected to the same power supply voltage to guarantee proper device operation.

NB7L1008

Table 2. ATTRIBUTES

Characteristics		Value
ESD Protection	Human Body Model Machine Model	> 2 kV > 200 V
Moisture Sensitivity (Note 3)	Indefinite Time of the Drypack QFN-32	Level 1
Flammability Rating	Oxygen Index: 28 to 34	UL 94 V-0 @ 0.125 in
Transistor Count		263
Meets or exceeds JEDEC Spec EIA/JESD78 IC Latchup Test		

3. For additional information, refer to Application Note AND8003/D.

Table 3. MAXIMUM RATINGS

Symbol	Parameter	Condition 1	Condition 2	Rating	Unit
V_{CC}	Positive Power Supply	GND = 0 V		4.0	V
V_{IN}	Input Voltage	GND = 0 V		-0.5 to V_{CC}	V
V_{INPP}	Differential Input Voltage $ I_N - \bar{I}_N $			1.89	V
I_{IN}	Input Current Through R_T (50 Ω Resistor)			± 40	mA
I_{out}	Output Current	Continuous Surge		34 40	mA
$I_{VFREFAC}$	V_{REFAC} Sink/Source Current			± 1.5	mA
T_A	Operating Temperature Range			-40 to +85	$^{\circ}C$
T_{stg}	Storage Temperature Range			-65 to +150	$^{\circ}C$
θ_{JA}	Thermal Resistance (Junction-to-Ambient) (Note 4) TGSD 51-6 (2S2P Multilayer Test Board) with Filled Thermal Vias	500 lfp/m	QFN-32	27	$^{\circ}C/W$
θ_{JC}	Thermal Resistance (Junction-to-Case)	Standard Board	QFN-32	12	$^{\circ}C/W$
T_{sol}	Wave Solder Pb-Free			265	$^{\circ}C$

Stresses exceeding those listed in the Maximum Ratings table may damage the device. If any of these limits are exceeded, device functionality should not be assumed, damage may occur and reliability may be affected.

4. JEDEC standard multilayer board – 2S2P (2 signal, 2 power) with 8 filled thermal vias under exposed pad.

NB7L1008

Table 4. DC CHARACTERISTICS – LVPECL OUTPUT $V_{CC} = 2.375\text{ V to }3.6\text{ V}$; $GND = 0\text{ V}$ $T_A = -40^\circ\text{C to }85^\circ\text{C}$ (Note 6)

Symbol	Characteristic	Min	Typ	Max	Unit
POWER SUPPLY CURRENT					
I_{CC}	Power Supply Current, Inputs and Outputs Open		165	215	mA
LVPECL OUTPUTS (Note 5, Figure 11)					
V_{OH}	Output HIGH Voltage $V_{CC} = 3.3\text{ V}$ $V_{CC} = 2.5\text{ V}$	$V_{CC} - 1025$ 2275 1475		$V_{CC} - 775$ 2525 1725	mV
V_{OL}	Output LOW Voltage $V_{CC} = 3.3\text{ V}$ $V_{CC} = 2.5\text{ V}$	$V_{CC} - 2000$ 1300 500		$V_{CC} - 1500$ 1800 1000	mV
DIFFERENTIAL INPUTS DRIVEN SINGLE-ENDED (Notes 7 and 8) (Figures 7 and 9)					
V_{IH}	Single-Ended Input HIGH Voltage	$V_{th} + 100$		V_{CC}	mV
V_{IL}	Single-Ended Input LOW Voltage	GND		$V_{th} - 100$	mV
V_{th}	Input Threshold Reference Voltage Range	1100		$V_{CC} - 100$	mV
V_{ISE}	Single-Ended Input Voltage ($V_{IH} - V_{IL}$)	200		1200	mV
V_{REFAC}					
V_{REFAC}	Output Reference Voltage @ 100 μA for Capacitor – Coupled Inputs, Only $V_{CC} = 3.3\text{ V}$ $V_{CC} = 2.5\text{ V}$	$V_{CC} - 1150$ $V_{CC} - 1150$	$V_{CC} - 1050$ $V_{CC} - 1050$	$V_{CC} - 950$ $V_{CC} - 950$	mV
DIFFERENTIAL INPUTS DRIVEN DIFFERENTIALLY (IN, $\bar{\text{IN}}$) (Note 9) (Figures 5 and 8)					
V_{IHD}	Differential Input HIGH Voltage	1100		V_{CC}	mV
V_{ILD}	Differential Input LOW Voltage	GND		$V_{IHD} - 100$	mV
V_{ID}	Differential Input Voltage ($V_{IHD} - V_{ILD}$)	100		1200	mV
I_{IH}	Input HIGH Current	-150	40	+150	μA
I_{IL}	Input LOW Current	-150	0	+150	μA
TERMINATION RESISTORS					
R_{TIN}	Internal Input Termination Resistor	45	50	55	Ω

NOTE: Device will meet the specifications after thermal equilibrium has been established when mounted in a test socket or printed circuit board with maintained transverse airflow greater than 500 lpm. Electrical parameters are guaranteed only over the declared operating temperature range. Functional operation of the device exceeding these conditions is not implied. Device specification limit values are applied individually under normal operating conditions and not valid simultaneously.

5. LVPECL outputs loaded with 50 Ω to $V_{CC} - 2\text{ V}$ for proper operation.
6. Input and output parameters vary 1:1 with V_{CC} .
7. V_{th} , V_{IH} , V_{IL} , and V_{ISE} parameters must be complied with simultaneously.
8. V_{th} is applied to the complementary input when operating in single-ended mode.
9. V_{IHD} , V_{ILD} , V_{ID} and V_{CMR} parameters must be complied with simultaneously.

NB7L1008

Table 5. AC CHARACTERISTICS $V_{CC} = 2.375\text{ V to }3.6\text{ V}$; $GND = 0\text{ V}$ $T_A = -40^\circ\text{C to }85^\circ\text{C}$ (Note 10)

Symbol	Characteristic	Min	Typ	Max	Unit
f_{DATA}	Maximum Operating Input Data Rate (Note 17)	10	12		Gb/s
f_{INCLK}	Maximum Input Clock Frequency, $V_{\text{OUTPP}} \geq 400\text{ mV}$ (Note 17)	5	7		GHz
V_{OUTPP}	Output Voltage Amplitude (see Figures 2 and 6, Notes 11, 17) $f_{\text{in}} \leq 5\text{ GHz}$	400			mV
V_{CMR}	Input Common Mode Range (Differential Configuration, Note 12, Figure 10)	600		$V_{\text{CC}} - 50$	mV
$t_{\text{PLH}}, t_{\text{PHL}}$	Propagation Delay to Output Differential, $\text{IN}/\overline{\text{IN}}$ to $\text{Qn}/\overline{\text{Qn}}$	100	160	220	ps
$t_{\text{PLH TC}}$	Propagation Delay Temperature Coefficient $-40^\circ\text{C to }+85^\circ\text{C}$		25		fs/ $^\circ\text{C}$
t_{DC}	Output Clock Duty Cycle $f_{\text{in}} \leq 5\text{ GHz}$	45	49/51	55	%
t_{SKEW}	Within Device Skew (Note 13) Device to Device Skew (Note 14)			20 100	ps
T_{jitter}	Clock Jitter RMS, 1000 Cycles (Note 17) $f_{\text{in}} \leq 6\text{ GHz}$ Data Dependent Jitter (DDJ) (Note 17) $\leq 10\text{ Gb/s}$		0.2 3	0.8 15	ps
T_{jitter} (additive)	622 MHz @ Integration Range of 12 kHz to 20 MHz		0.025		ps
V_{INPP}	Input Voltage Swing (Differential Configuration) (Note 16) (Figure 6)	100		1200	mV
t_r, t_f	Output Rise/Fall Times (20% – 80%) $\text{Qn}, \overline{\text{Qn}}$	20	50	80	ps

NOTE: Device will meet the specifications after thermal equilibrium has been established when mounted in a test socket or printed circuit board with maintained transverse airflow greater than 500 lfm. Electrical parameters are guaranteed only over the declared operating temperature range. Functional operation of the device exceeding these conditions is not implied. Device specification limit values are applied individually under normal operating conditions and not valid simultaneously.

- 10. All outputs must be loaded with external $50\ \Omega$ to $V_{\text{CC}} - 2\text{ V}$.
- 11. Output voltage swing is a single-ended measurement operating in differential mode.
- 12. $V_{\text{IHD}_{\text{MIN}}} \geq 1100\text{ mV}$.
- 13. Within device skew compares coincident edges.
- 14. Device to device skew is measured between outputs under identical transition
- 15. Additive CLOCK jitter with 50% duty cycle clock signal input.
- 16. Input voltage swing is a single-ended measurement operating in differential mode.
- 17. V_{CC} of 2.5–3.3, input = 800 mv_{p-p}

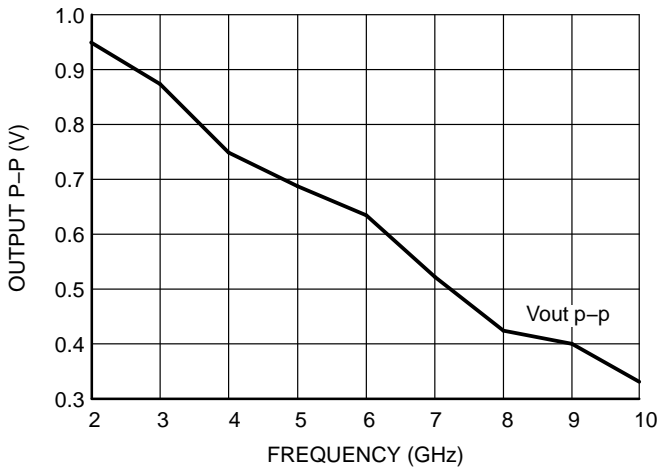

Figure 2. Typical $V_{\text{OUT P-P}}$ vs. Frequency at 25°C

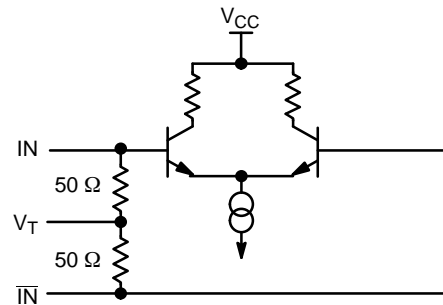

Figure 3. Input Structure

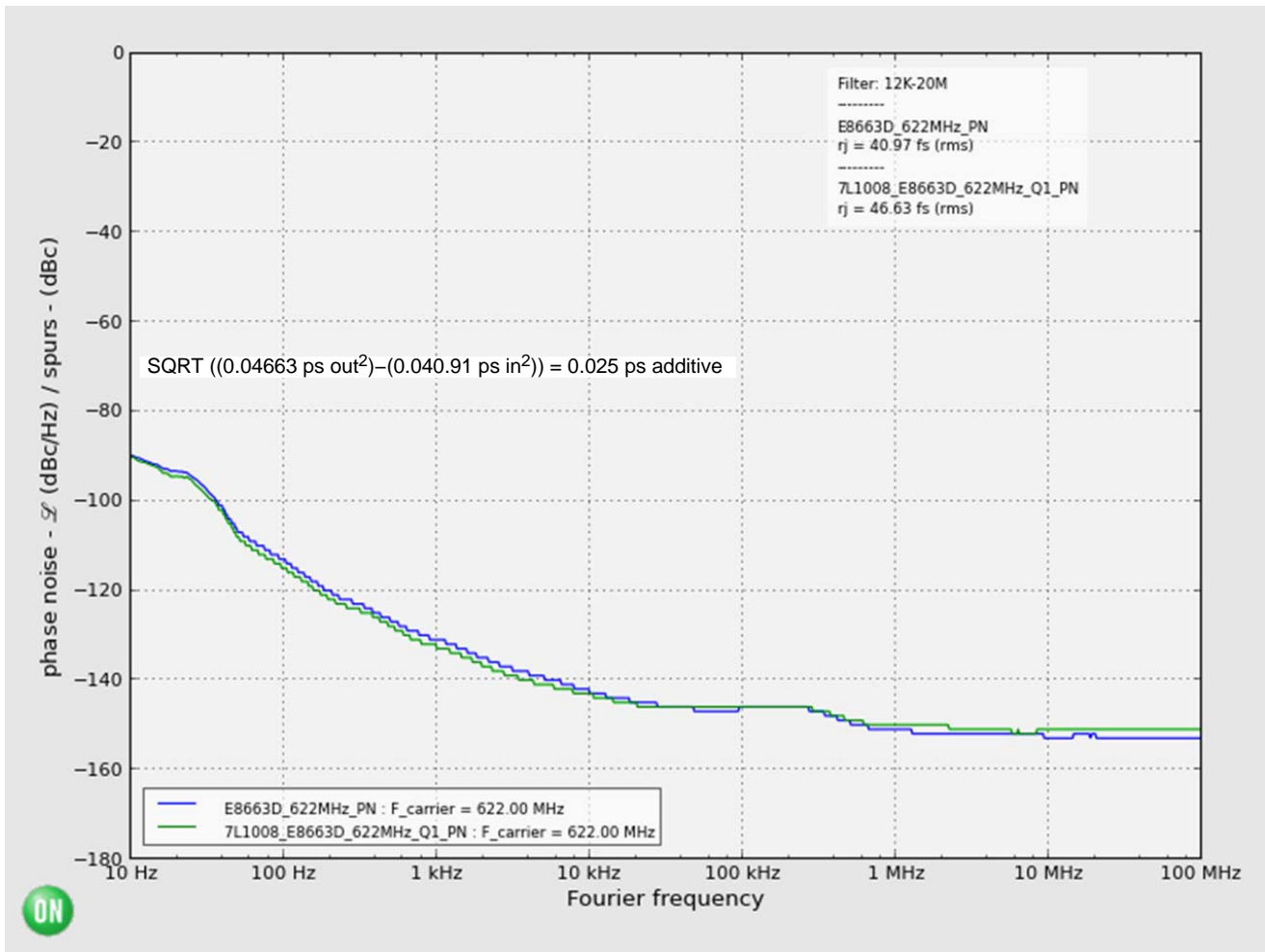

Figure 4. Additive Phase Jitter RMS from 12 kHz to 20 MHz @ 622 MHz, Typical 0.025 ps

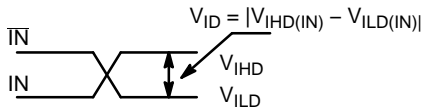

Figure 5. Differential Inputs Driven Differentially

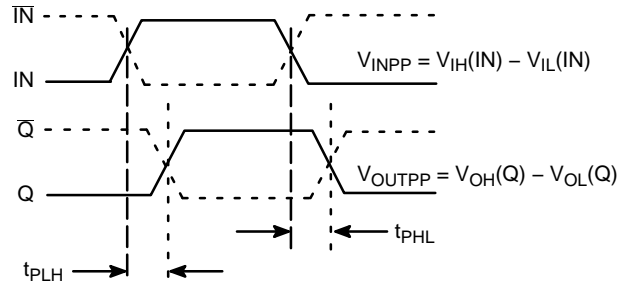

Figure 6. AC Reference Measurement

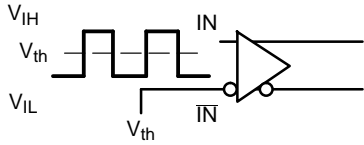

Figure 7. Differential Input Driven Single-Ended

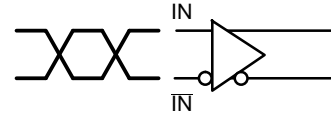

Figure 8. Differential Inputs Driven Differentially

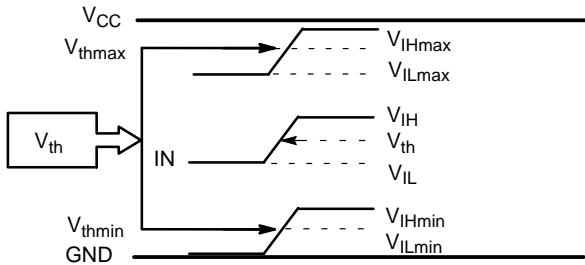

Figure 9. V_{th} Diagram

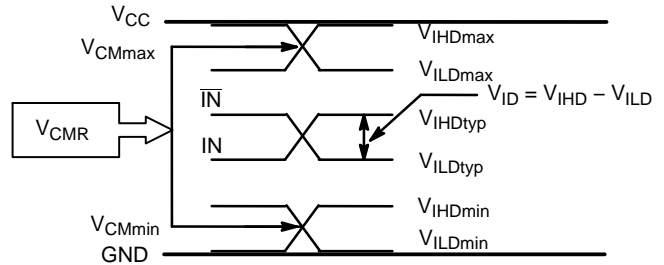

Figure 10. V_{CM} Diagram

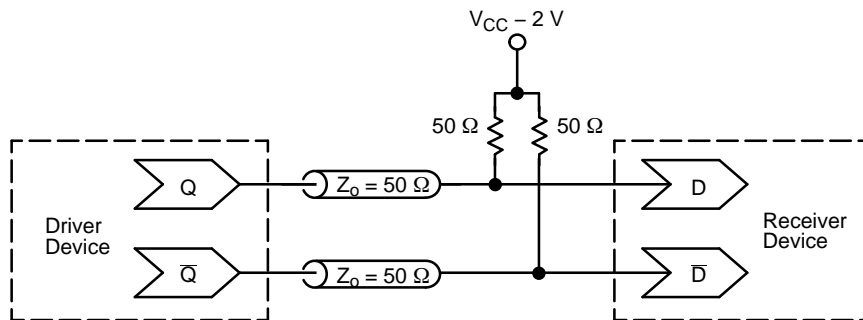

Figure 11. Typical Termination for Output Driver and Device Evaluation
(See Application Note AND8173/D)

NB7L1008

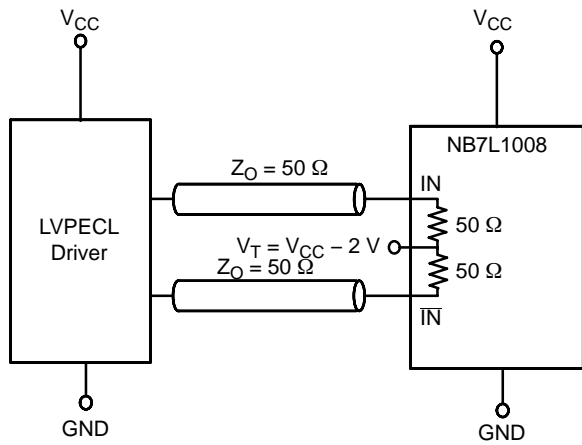

Figure 12. LVPECL Interface

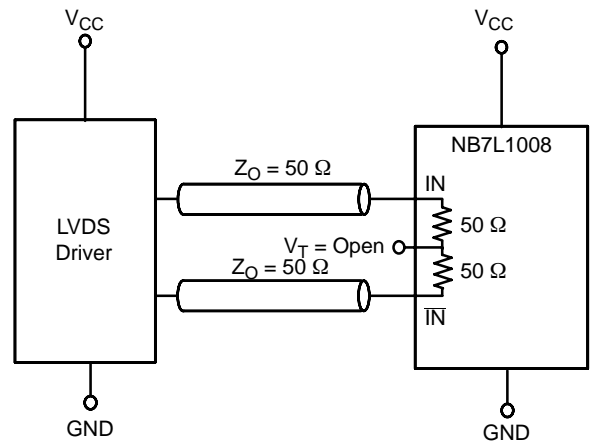

Figure 13. LVDS Interface

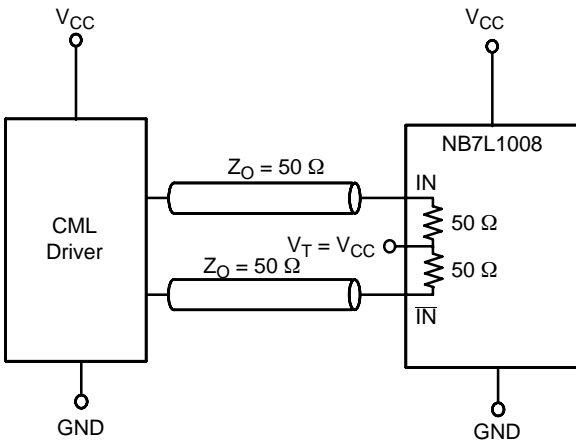

Figure 14. Standard 50 Ω Load CML Interface

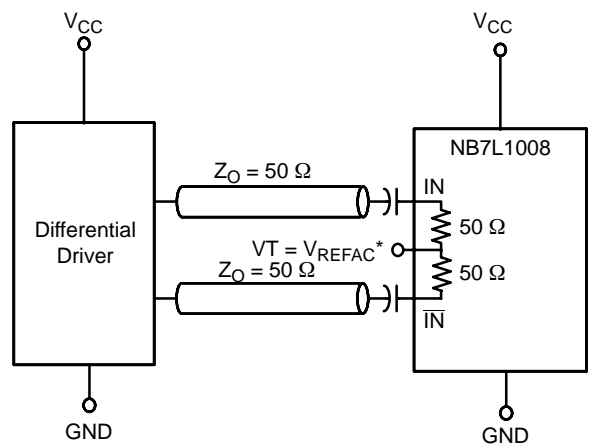

Figure 15. Capacitor-Coupled Differential Interface
(V_T Connected to V_{REFAC})

* V_{REFAC} bypassed to ground with a 0.01 μF capacitor

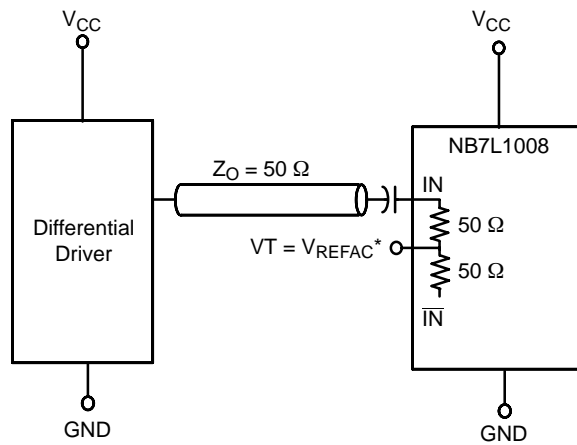

Figure 16. Capacitor-Coupled Single-Ended Interface
(V_T Connected to V_{REFAC})

NB7L1008

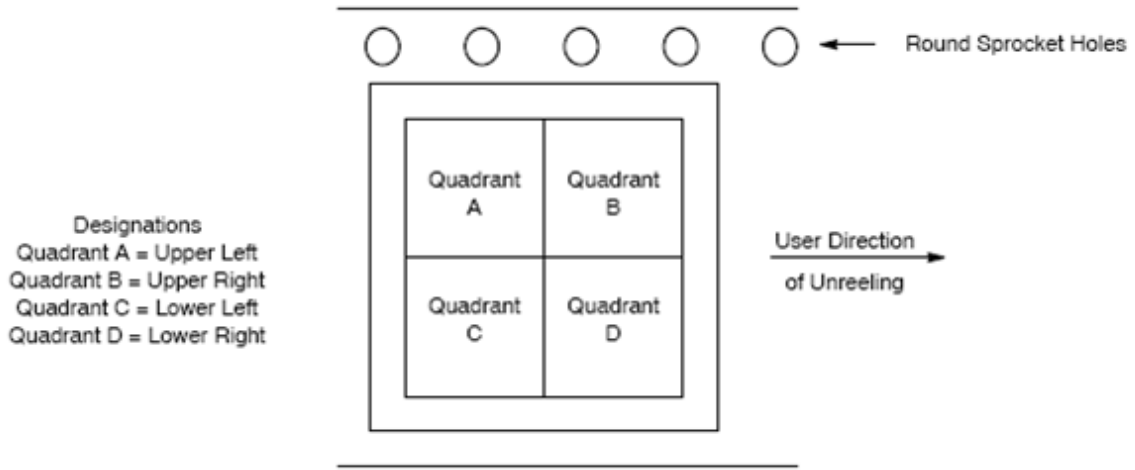

Figure 17. Tape and Reel Pin 1 Quadrant Orientation

ORDERING INFORMATION

Device	Package	Shipping
NB7L1008MNG	QFN32 (Pb-Free/Halide-Free)	74 Units / Rail
NB7L1008MNTXG	QFN32 (Pb-Free/Halide-Free)	1000 / Tape & Reel (Pin 1 Orientation in Quadrant B, Figure 17)

†For information on tape and reel specifications, including part orientation and tape sizes, please refer to our Tape and Reel Packaging Specifications Brochure, BRD8011/D.

NB7L1008

PACKAGE DIMENSIONS

QFN32 5x5, 0.5P
CASE 488AM
ISSUE A

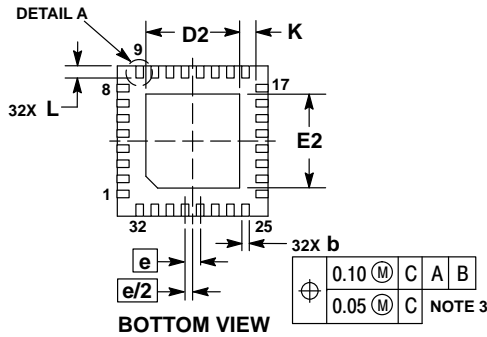
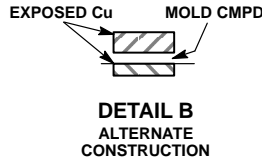
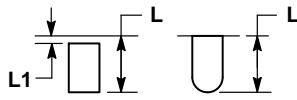
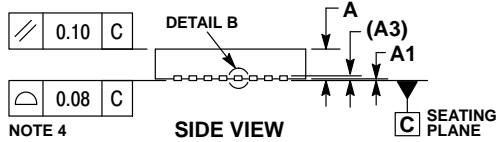
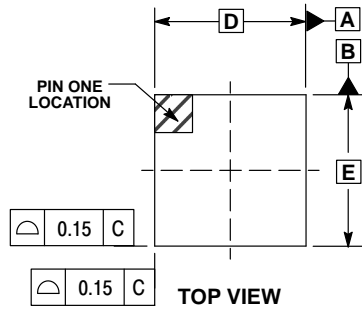

NOTES:

1. DIMENSIONS AND TOLERANCING PER ASME Y14.5M, 1994.
2. CONTROLLING DIMENSION: MILLIMETERS.
3. DIMENSION b APPLIES TO PLATED TERMINAL AND IS MEASURED BETWEEN 0.15 AND 0.30MM FROM THE TERMINAL TIP.
4. COPLANARITY APPLIES TO THE EXPOSED PAD AS WELL AS THE TERMINALS.

DIM	MILLIMETERS	
	MIN	MAX
A	0.80	1.00
A1	---	0.05
A3	0.20	REF
b	0.18	0.30
D	5.00	BSC
D2	2.95	3.25
E	5.00	BSC
E2	2.95	3.25
e	0.50	BSC
K	0.20	---
L	0.30	0.50
L1	---	0.15

**RECOMMENDED
SOLDERING FOOTPRINT***

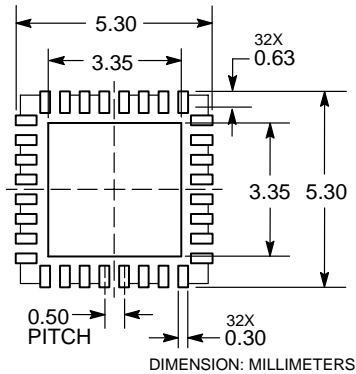

*For additional information on our Pb-Free strategy and soldering details, please download the ON Semiconductor Soldering and Mounting Techniques Reference Manual, SOLDERRM/D.

GigaComm is a trademark of Semiconductor Components Industries, LLC (SCILLC).

ON Semiconductor and are registered trademarks of Semiconductor Components Industries, LLC (SCILLC). SCILLC owns the rights to a number of patents, trademarks, copyrights, trade secrets, and other intellectual property. A listing of SCILLC's product/patent coverage may be accessed at www.onsemi.com/site/pdf/Patent-Marking.pdf. SCILLC reserves the right to make changes without further notice to any products herein. SCILLC makes no warranty, representation or guarantee regarding the suitability of its products for any particular purpose, nor does SCILLC assume any liability arising out of the application or use of any product or circuit, and specifically disclaims any and all liability, including without limitation special, consequential or incidental damages. "Typical" parameters which may be provided in SCILLC data sheets and/or specifications can and do vary in different applications and actual performance may vary over time. All operating parameters, including "Typicals" must be validated for each customer application by customer's technical experts. SCILLC does not convey any license under its patent rights nor the rights of others. SCILLC products are not designed, intended, or authorized for use as components in systems intended for surgical implant into the body, or other applications intended to support or sustain life, or for any other application in which the failure of the SCILLC product could create a situation where personal injury or death may occur. Should Buyer purchase or use SCILLC products for any such unintended or unauthorized application, Buyer shall indemnify and hold SCILLC and its officers, employees, subsidiaries, affiliates, and distributors harmless against all claims, costs, damages, and expenses, and reasonable attorney fees arising out of, directly or indirectly, any claim of personal injury or death associated with such unintended or unauthorized use, even if such claim alleges that SCILLC was negligent regarding the design or manufacture of the part. SCILLC is an Equal Opportunity/Affirmative Action Employer. This literature is subject to all applicable copyright laws and is not for resale in any manner.

PUBLICATION ORDERING INFORMATION

LITERATURE FULFILLMENT:
Literature Distribution Center for ON Semiconductor
P.O. Box 5163, Denver, Colorado 80217 USA
Phone: 303-675-2175 or 800-344-3860 Toll Free USA/Canada
Fax: 303-675-2176 or 800-344-3867 Toll Free USA/Canada
Email: orderlit@onsemi.com

N. American Technical Support: 800-282-9855 Toll Free
USA/Canada
Europe, Middle East and Africa Technical Support:
Phone: 421 33 790 2910
Japan Customer Focus Center
Phone: 81-3-5817-1050

ON Semiconductor Website: www.onsemi.com
Order Literature: <http://www.onsemi.com/orderlit>
For additional information, please contact your local Sales Representative

Компания «Life Electronics» занимается поставками электронных компонентов импортного и отечественного производства от производителей и со складов крупных дистрибьюторов Европы, Америки и Азии.

С конца 2013 года компания активно расширяет линейку поставок компонентов по направлению коаксиальный кабель, кварцевые генераторы и конденсаторы (керамические, пленочные, электролитические), за счёт заключения дистрибьюторских договоров

Мы предлагаем:

- Конкуренспособные цены и скидки постоянным клиентам.
- Специальные условия для постоянных клиентов.
- Подбор аналогов.
- Поставку компонентов в любых объемах, удовлетворяющих вашим потребностям.
- Приемлемые сроки поставки, возможна ускоренная поставка.
- Доставку товара в любую точку России и стран СНГ.
- Комплексную поставку.
- Работу по проектам и поставку образцов.
- Формирование склада под заказчика.
- Сертификаты соответствия на поставляемую продукцию (по желанию клиента).
- Тестирование поставляемой продукции.
- Поставку компонентов, требующих военную и космическую приемку.
- Входной контроль качества.
- Наличие сертификата ISO.

В составе нашей компании организован Конструкторский отдел, призванный помогать разработчикам, и инженерам.

Конструкторский отдел помогает осуществить:

- Регистрацию проекта у производителя компонентов.
- Техническую поддержку проекта.
- Защиту от снятия компонента с производства.
- Оценку стоимости проекта по компонентам.
- Изготовление тестовой платы монтаж и пусконаладочные работы.



Тел: +7 (812) 336 43 04 (многоканальный)

Email: org@lifeelectronics.ru