

EVALUATION KIT  
AVAILABLE

# MAXIM

## Single-Cell Li+ Battery Charger for Current-Limited Supply

MAX1679

### General Description

The MAX1679 battery charger for a single lithium-ion (Li+) cell comes in a space-saving 8-pin  $\mu$ MAX package. This simple device, in conjunction with a current-limited wall cube and a PMOS transistor, allows safe and fast charging of a single Li+ cell.

The MAX1679 initiates charging in one of three ways: battery insertion, charger power-up, or external manipulation of the THERM pin. Charging terminates when the average charging current falls to approximately 1% of the fast-charge current, or when the on-chip counter times out.

Key safety features include continuous voltage and temperature monitoring, a programmable charger timeout, and a 5mA precharge current mode to charge near-dead cells. Automatic detection of input power removal shuts down the device, minimizing current drain from the battery. An overall system accuracy of 0.75% ensures that the cell capacity is fully utilized without cycle life degradation.

The MAX1679 evaluation kit (MAX1679EVKIT) is available to help reduce design time.

### Applications

Single-Cell Li+ Portable Applications  
Self-Charging Battery Packs  
PDAs  
Cell Phones  
Cradle Chargers

### Pin Configuration

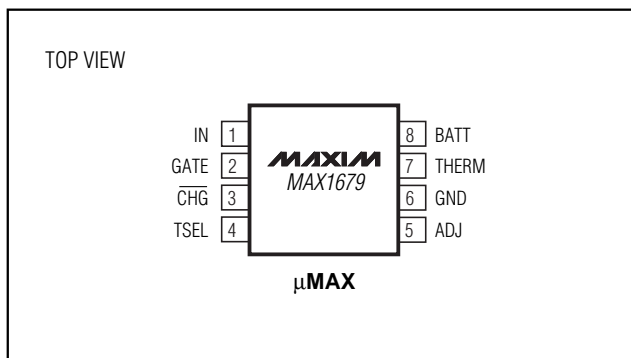

### Features

- ◆ Simple Stand-Alone Application Circuit
- ◆ Lowest Power Dissipation
- ◆ 8-Pin  $\mu$ MAX Package Saves Space
- ◆ No Inductor Required
- ◆ 0.75% Overall System Accuracy
- ◆ Continuous Voltage and Temperature Protection
- ◆ Safely Precharges Near-Dead Cells
- ◆ Programmable Safety Timeout
- ◆ Top-Off Charging to Achieve Full Battery Capacity
- ◆ Automatic Power-Down when Power Source is Removed

### Ordering Information

PART	TEMP. RANGE	PIN-PACKAGE
MAX1679EUA	-40°C to +85°C	8 $\mu$ MAX

### Typical Operating Circuit

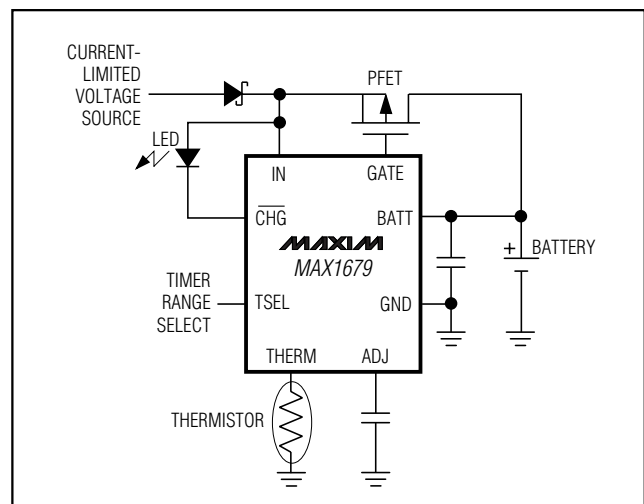

MAXIM

Maxim Integrated Products 1

For free samples & the latest literature: <http://www.maxim-ic.com>, or phone 1-800-998-8800.  
For small orders, phone 1-800-835-8769.

# Single-Cell Li+ Battery Charger for Current-Limited Supply

## ABSOLUTE MAXIMUM RATINGS

IN, CHG, GATE to GND .....	-0.3V to +26V
BATT, TSEL, THERM, ADJ to GND .....	-0.3V to +6V
GATE to IN.....	-6V to +0.3V
THERM, ADJ to BATT.....	-6V to +0.3V
GATE Continuous Current .....	-10mA

Continuous Power Dissipation ( $T_A = +70^\circ\text{C}$ )	
8-Pin $\mu\text{MAX}$ (derate 4.1mW/ $^\circ\text{C}$ above $+70^\circ\text{C}$ ) .....	330mW
Operating Temperature Range .....	$-40^\circ\text{C}$ to $+85^\circ\text{C}$
Storage Temperature Range .....	$-65^\circ\text{C}$ to $+150^\circ\text{C}$
Lead Temperature (soldering, 10sec) .....	$+300^\circ\text{C}$

Stresses beyond those listed under "Absolute Maximum Ratings" may cause permanent damage to the device. These are stress ratings only, and functional operation of the device at these or any other conditions beyond those indicated in the operational sections of the specifications is not implied. Exposure to absolute maximum rating conditions for extended periods may affect device reliability.

## ELECTRICAL CHARACTERISTICS

( $V_{IN} = V_{CHG} = +10\text{V}$ ,  $V_{BATT} = +4.2\text{V}$ , TSEL = GND, GATE = unconnected, ADJ = unconnected, THERM = 10k $\Omega$  to GND,  $T_A = 0^\circ\text{C}$  to  $+85^\circ\text{C}$ , unless otherwise noted. Typical values are at  $T_A = +25^\circ\text{C}$ .)

PARAMETER	SYMBOL	CONDITIONS	MIN	TYP	MAX	UNITS
Input Voltage (Note 1)	$V_{IN}$	External PMOS FET off	5		22	V
Input Voltage for Removable Battery (Note 1)	$V_{IN}$	External PMOS FET off	6		22	V
Undervoltage Lockout Trip Point		$V_{BATT}$ rising	2.1	2.2	2.3	V
Undervoltage Lockout Trip-Point Hysteresis		$V_{BATT}$ falling		60		mV
Fast-Charge Qualification Threshold		$V_{BATT}$ rising, transition from precharge to full current	2.425	2.500	2.575	V
Fast-Charge Restart Threshold		$V_{BATT}$ falling, transition from DONE to PREQUAL state (Figure 2)	3.783	3.89	4.00	V
Precharge Source Current		$V_{BATT} = 2\text{V}$	4	5	6	mA
BATT Regulation Voltage			4.1685	4.2000	4.2315	V
BATT Regulation Adjust Range			4.0		4.2	V
ADJ Source Impedance			9.8	10	10.2	k $\Omega$
ADJ Output Voltage		No load on ADJ	1.393	1.400	1.407	V
Battery Removal Detection Threshold		$V_{BATT}$ rising	4.875	5.0	5.125	V
Battery Removal Detection Threshold Hysteresis		$V_{BATT}$ falling		125		mV
BATT Input Current (Note 2)		$V_{IN} \leq V_{BATT} - 0.3\text{V}$		0.1	1	$\mu\text{A}$
BATT Input Current, Fast-Charge State	$I_{BATT}$	$V_{BATT} = 4\text{V}$		900	1500	$\mu\text{A}$
BATT Input Current, Done State	$I_{BATT}$	$V_{BATT} = 4.25\text{V}$		500	1000	$\mu\text{A}$
IN Input Current, Fast-Charge State	$I_{IN}$	$V_{BATT} = 4\text{V}$ , $V_{IN} = 4\text{V}$		30	100	$\mu\text{A}$
IN Input Current, Done State	$I_{IN}$	$V_{BATT} = 4.25\text{V}$ , $V_{IN} = 22\text{V}$		250	600	$\mu\text{A}$
Timer Accuracy		See Table 3	-10		+10	%
CHG Output Leakage Current		$V_{CHG} = 22\text{V}$ , $\overline{\text{CHG}} = \text{high}$	-1		+1	$\mu\text{A}$

# Single-Cell Li+ Battery Charger for Current-Limited Supply

MAX1679

## ELECTRICAL CHARACTERISTICS (continued)

( $V_{IN} = V_{\overline{CHG}} = +10V$ ,  $V_{BATT} = +4.2V$ , TSEL = GND, GATE = unconnected, ADJ = unconnected, THERM = 10k $\Omega$  to GND,  $T_A = 0^\circ C$  to  $+85^\circ C$ , unless otherwise noted. Typical values are at  $T_A = +25^\circ C$ .)

PARAMETER	SYMBOL	CONDITIONS	MIN	TYP	MAX	UNITS
CHG Output Sink Current		$V_{\overline{CHG}} = 1V$ , $\overline{CHG} = \text{low}$	4	5	6	mA
THERM Sense Current (for hot qualification)			346	352.9	360	$\mu A$
THERM Sense Current (for cold qualification)			47.8	48.8	49.8	$\mu A$
THERM Sense Voltage Trip Point			1.379	1.40	1.421	V
GATE Source/Sink Current		$V_{IN} = 10V$ , $V_{GATE} = 8V$	75	105	130	$\mu A$
GATE Drive Current at Battery Removal		$V_{BATT} = 5.1V$ , gate driven high	20	40	60	mA

## ELECTRICAL CHARACTERISTICS

( $V_{IN} = V_{\overline{CHG}} = +10V$ ,  $V_{BATT} = +4.2V$ , TSEL = GND, GATE = unconnected, ADJ = unconnected, THERM = 10k $\Omega$  to GND,  $T_A = -40^\circ C$  to  $+85^\circ C$ , unless otherwise noted.)

PARAMETER	SYMBOL	CONDITIONS	MIN	MAX	UNITS
Input Voltage (Note 1)	$V_{IN}$	External PMOS FET off	5	22	V
Input Voltage for Removable Battery (Note 1)	$V_{IN}$	External PMOS FET off	6	22	V
Undervoltage Lockout Trip Point		$V_{BATT}$ rising	2.05	2.35	V
Fast-Charge Qualification Threshold		$V_{BATT}$ rising, transition from precharge to full current	2.35	2.65	V
Fast-Charge Restart Threshold		$V_{BATT}$ falling, transition from DONE to PREQUAL state, Figure 2	3.74	4.04	V
Precharge Source Current		$V_{BATT} = 2V$	3	7	mA
BATT Regulation Voltage			4.137	4.263	V
BATT Regulation Adjust Range			4.0	4.2	V
ADJ Source Impedance			9.8	10.2	k $\Omega$
ADJ Output Voltage		No load on ADJ	1.386	1.414	V
Battery Removal Detection Threshold		$V_{BATT}$ rising	4.850	5.150	V
BATT Input Current (Note 2)		$V_{IN} \leq V_{BATT} - 0.3V$		1	$\mu A$
BATT Input Current, Fast-Charge State	$I_{BATT}$	$V_{BATT} = 4.0V$		1500	$\mu A$
BATT Input Current, Done State	$I_{BATT}$	$V_{BATT} = 4.25V$		1000	$\mu A$
IN Input Current, Fast-Charge State	$I_{IN}$	$V_{BATT} = 4.0V$ , $V_{IN} = 4.0V$		100	$\mu A$

# Single-Cell Li+ Battery Charger for Current-Limited Supply

## ELECTRICAL CHARACTERISTICS (continued)

( $V_{IN} = V_{\overline{CHG}} = +10V$ ,  $V_{BATT} = +4.2V$ , TSEL = GND, GATE = unconnected, ADJ = unconnected, THERM = 10k $\Omega$  to GND,  $T_A = -40^\circ C$  to  $+85^\circ C$ , unless otherwise noted.)

PARAMETER	SYMBOL	CONDITIONS	MIN	MAX	UNITS
IN Input Current, Done State	$I_{IN}$	$V_{BATT} = 4.25V$ , $V_{IN} = 22V$		700	$\mu A$
Timer Accuracy		See Table 3	-15	+15	%
$\overline{CHG}$ Output Leakage Current		$V_{\overline{CHG}} = 22V$ , $\overline{CHG} = \text{high}$	-1	+1	$\mu A$
$\overline{CHG}$ Output Sink Current		$V_{\overline{CHG}} = 1.0V$ , $\overline{CHG} = \text{low}$	4	6	mA
THERM Sense Current (for hot qualification)			342	363	$\mu A$
THERM Sense Current (for cold qualification)			47.3	50.3	$\mu A$
THERM Sense Voltage Trip Point			1.358	1.442	V
GATE Source/Sink Current		$V_{IN} = 10V$ , $V_{GATE} = 8V$	60	140	$\mu A$
GATE Drive Current at Battery Removal		$V_{BATT} = 5.1V$ , gate driven high	20	90	mA

**Note 1:** The input voltage range is specified with the external PFET off. When charging, the PFET turns on and the input voltage (the output voltage of the constant-current power source) drops to very near the battery voltage. When the PFET is on,  $V_{IN}$  may be as low as 2.5V.

**Note 2:** BATT Input Current is the supply current to the device. When  $V_{IN}$  is removed, the MAX1679 shuts down and the input current is less than 1 $\mu A$ , even if there is an external  $R_{ADJ}$  resistor (ADJ to GND).

# Single-Cell Li+ Battery Charger for Current-Limited Supply

## Typical Operating Characteristics

( $V_{IN} = V_{\overline{CHG}} = +10V$ ,  $V_{BATT} = +4.2V$ , THERM = 10k $\Omega$  to GND,  $T_A = +25^\circ C$ , unless otherwise noted.)

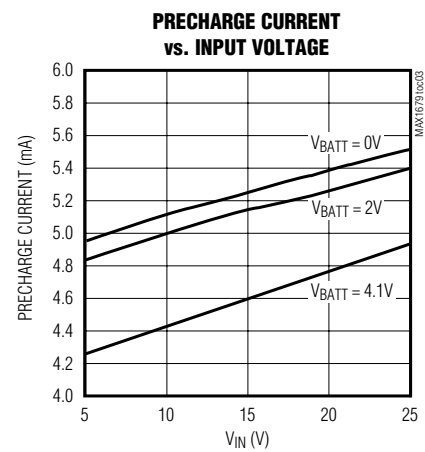
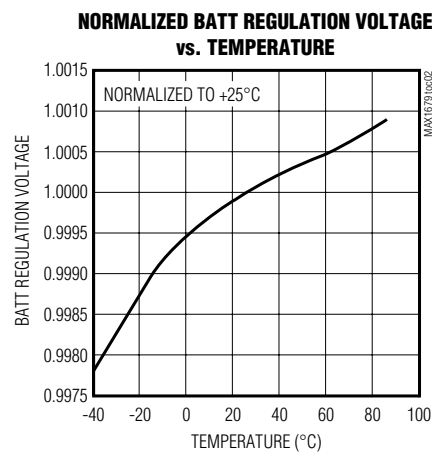
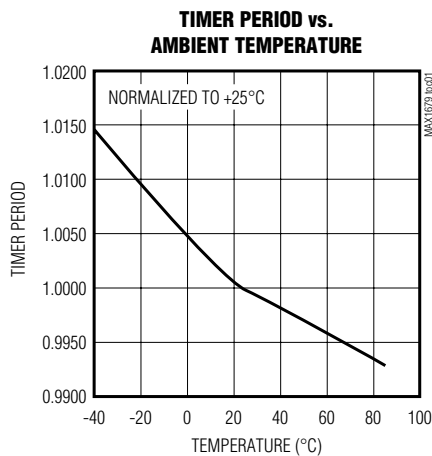

MAX1679

## Pin Description

PIN	NAME	FUNCTION
1	IN	Input Voltage from Current-Limited Voltage Source (+22V max). Bypass to GND with a 0.1 $\mu F$ capacitor. The cell charging current is set by the current limit of the external power supply.
2	GATE	Gate Drive for External PMOS Pass Element. The PMOS device should have a $V_{GS}$ threshold of 2.5V or less. See <i>Selecting External Components</i> .
3	$\overline{CHG}$	Charge Status Indication. $\overline{CHG}$ is an open-drain, current-limited N-channel MOSFET suitable for directly driving an LED. Connect a pull-up resistor to BATT to generate a logic-level signal. See Table 2 for $\overline{CHG}$ output states.
4	TSEL	Maximum Total Charge-Time Selection. See Table 3 for timer options.
5	ADJ	Battery Regulation Voltage Adjustment. Bypass to GND with a 1000pF capacitor. Connect a resistor from ADJ to GND to reduce the nominal +4.200V regulation setpoint. See <i>Adjusting the Battery Regulation Voltage</i> .
6	GND	Ground. See <i>Layout Guidelines</i> for information on system grounding. Connect the battery's negative terminal to GND.
7	THERM	Thermistor Temperature-Sensor Input. Connect a thermistor from THERM to GND to prequalify the cell temperature for fast-charge. Drive THERM high (> +1.4V) during Done or Fault states to reset the MAX1679 and reinitiate the charging sequence. Replace the thermistor with a 10k $\Omega$ resistor if temperature sensing is not required.
8	BATT	Cell Voltage Monitor Input, Trickle-Charge Output, and MAX1679 Power Source. Connect BATT to the positive terminal of a single Li+ cell. Bypass BATT with a capacitor to ground (1.5 $\mu F$ per amp of charge current).

# Single-Cell Li+ Battery Charger for Current-Limited Supply

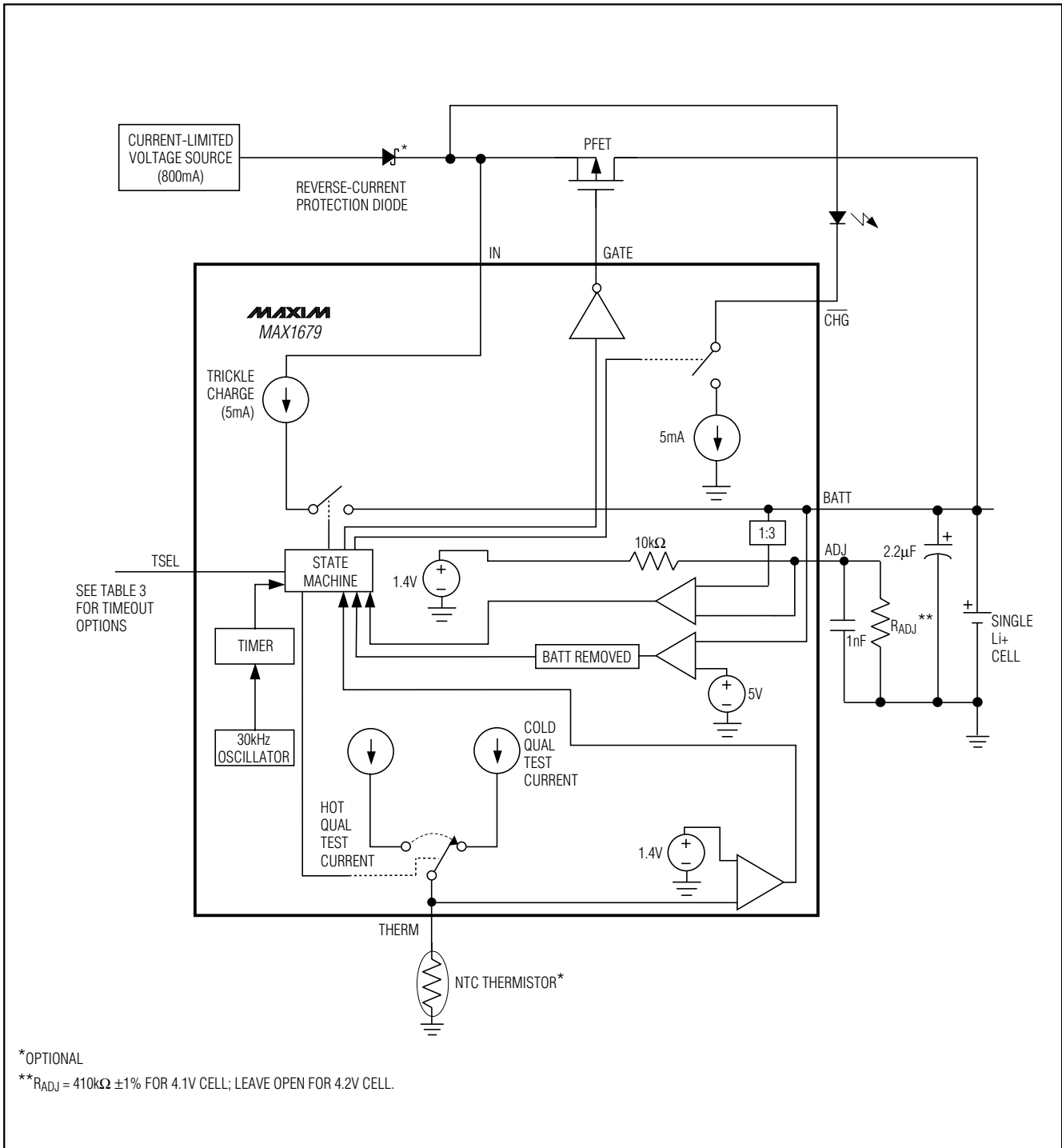

Figure 1. Functional Diagram

# Single-Cell Li+ Battery Charger for Current-Limited Supply

MAX1679

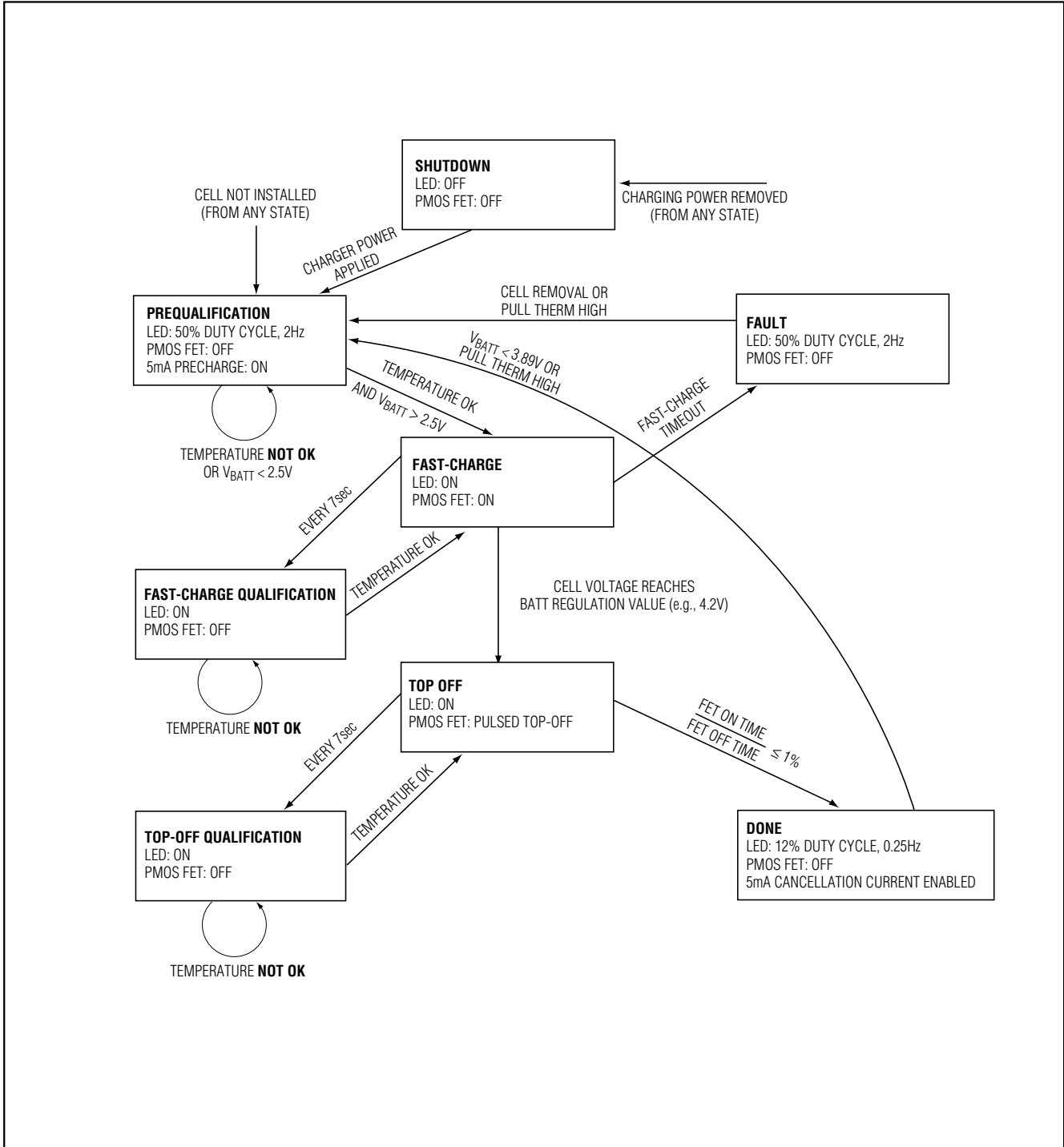

Figure 2. State Machine Diagram

# Single-Cell Li+ Battery Charger for Current-Limited Supply

## Detailed Description

### Initiating a Charge Cycle

The MAX1679 attempts to initiate fast-charge upon insertion of the battery or application of an external power source (current-limited wall cube). After charge completion, charging restarts when the cell voltage drops below 3.89V or when THERM is pulled above 1.4V.

Before a charge cycle can begin, the cell conditions are verified to be within safe limits. The cell voltage must be greater than 2.5V but less than the regulation voltage (default value 4.2V). In addition, the thermistor must indicate an acceptable cell temperature (the default range is +2.5°C to +47.5°C). See the *Applications Information* section.

Li+ cells can be damaged when fast-charged from a completely dead state. Moreover, a fully discharged cell may indicate a dangerously abnormal cell condition. As a built-in safety feature, the MAX1679 precharges the Li+ cell with 5mA at the start of a charge cycle when the cell voltage is below 2.5V. Typically, 5mA is sufficient to bring a fully discharged 1000mAh Li+ cell up to 2.5V in less than 5 minutes. As soon as the cell's voltage reaches 2.5V and all the other prerequisites are met (see the *Fast-Charge* section), the MAX1679 begins fast-charging the cell.

If the temperature is outside the programmed range, the charger waits. Once all prequalification conditions are met, the charging cycle and timers begin. The MAX1679 continues to monitor these conditions throughout the charging cycle.

### Fast-Charge

Once all cell conditions are determined to be satisfactory, the MAX1679 begins fast-charging the Li+ cell by turning on the external PMOS FET. **The cell charging current is set by the current limit of the external power supply;** it is *not* regulated by the MAX1679. The PMOS FET is used as a simple switch, not as a linear regulator. Therefore, the circuit's power dissipation is minimized, permitting rapid charge cycles with minimal heat generation. The external power supply should have a specified current limit that matches the desired fast-charge current for the Li+ cell.

Fast-charge continues until one of the following conditions is reached: 1) cell voltage climbs to the battery regulation voltage (4.2V or as set by ADJ); 2) the fast-charging timer expires (fault condition); or 3) cell temperature rises above +47.5°C or falls below +2.5°C. If the cell temperature moves outside the specified limits, charging is suspended but not terminated. All timers are paused and charging resumes when the temperature returns to the normal range.

### Pulsed Top-Off Charge

In the most common case, where fast-charge is terminated because the battery regulation voltage has been reached (that is, the cell is nearly fully charged), the MAX1679 will top off the cell. The MAX1679 uses a hysteretic algorithm with minimum on-times and minimum off-times (Table 3). The cell voltage is sampled every 2ms. If the cell voltage (at BATT) is less than the battery regulation voltage, the external PMOS FET turns on or remains on. If the cell voltage is greater than, or equal to, the battery regulation voltage, the FET turns off or remains off until the next sample. By also measuring the cell voltage when the PMOS FET is off, the MAX1679 eliminates voltage errors caused by charging current flowing through the series resistance of protection switches or fuse links that may be in the charging path.

At the beginning of this top-off state, the current stays on for many consecutive cycles between single off periods. As the cell continues to charge, the percentage of time spent in the "current-on" mode decreases. Toward the end of top off, the current stays off for many cycles between single "on" pulses. During these final pulses, the instantaneous cell voltage may exceed the battery regulation voltage by several hundred millivolts, but the duration of these pulses is several orders of magnitude shorter than the intrinsic chemical time constant of Li+ cells. This does not harm the cell. Cell top off is completed either when the duty ratio of "on" cycles to "off" cycles falls below 1/64 to 1/256 as set by TSEL (see Table 3), or when the charging timer expires.

### Switched 5mA Cancellation Current

When the charge cycle is complete, the MAX1679 replaces current drawn by the BATT pin (to sense battery removal) with a 5mA (nominal) switched current. This current is turned on and off by an on-chip comparator as needed to maintain the battery regulation voltage. The cell is maintained in this manner as long as the battery is inserted and power is connected. This cancellation current is turned off when the MAX1679 is shut down. Note that BATT draws less than 1μA from the battery when power is removed.

### Charge Status with CHG

$\overline{\text{CHG}}$  indicates the cell's charging status. An LED can be connected directly from IN to  $\overline{\text{CHG}}$  for a visible indicator. Alternatively, a pull-up resistor (typically 100kΩ) from a logic supply to  $\overline{\text{CHG}}$  provides a logic-level output. Table 2 relates the status of the  $\overline{\text{CHG}}$  to the condition of the charger.



# Single-Cell Li+ Battery Charger for Current-Limited Supply

## Applications Information

The MAX1679 was designed to offer the maximum integration and functionality in the smallest, most basic application circuit possible. The only necessary external components are a current-limited wall cube, a PMOS FET, two small capacitors, and a 10kΩ thermistor/resistor. This simple application circuit appears in Figure 3. Optionally (as shown in Figure 4), an LED can be added as a charge-state indicator, a resistor (RADJ) can be used to trim down the maximum charge voltage from 4.2V, and/or a reverse-current-protection diode can be added in line at the source.

If the input is shorted, the MAX1679 will not allow current to flow from BATT back through IN to the source. However, the body diode inherent in the enhancement-

mode FET would still allow the cell to discharge rapidly. To prevent this, add a power Schottky diode between the source and IN as in Figure 4.

### Adjusting the Battery Regulation Voltage

A typical Li+ cell should be charged at a constant current until it reaches a voltage of about 4.2V, then charged at this voltage until the current decays below a predetermined level. The MAX1679 provides a simple way to reduce this maximum target voltage with a single resistor between ADJ and GND. Internally, ADJ connects to a precision 1.4V reference through a 10kΩ resistor. Leave ADJ open for a battery regulation voltage (VBR) of 4.2V; connect a 1% resistor from ADJ to GND to form a voltage divider for lower battery regulation voltage (VBRϕ). Select the external value using:

$$R_{ADJ} = \frac{10k\Omega}{\frac{V_{BR}}{V_{BR\phi}} - 1}$$

A 1% tolerance resistor at ADJ degrades system accuracy by only a fraction of a percent. For example, an RADJ of 410kΩ ±1% reduces the battery regulation voltage by 2.4% (VBRϕ = 4.1V from equation above, and (VBRϕ - VBR) / VBR = (4.1 - 4.2) / 4.2 = -2.4%). Therefore, the additional system error is simply the RADJ tolerance multiplied by the percent change in the battery regulation voltage, or (1%)(2.4%) = 0.024%.

**Table 2. CHG Output States**

CONDITION	CHG
No battery or no charger, or cell voltage < 2.2V	High impedance
Fast-charge or pulsed top-off charge in progress	Low (LED on)
Fast-charge timer expiration or initial prequalification state (VBATT < 2.5V or initial temperature fault)	2Hz, 50% duty factor (LED flashing)
Charge cycle complete	LED blinking 0.5sec on (low), 3.5sec off (high impedance)

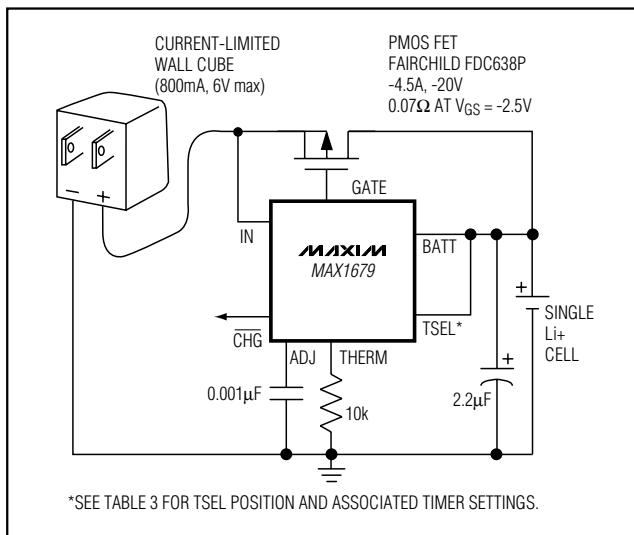

Figure 3. Simple Application Circuit

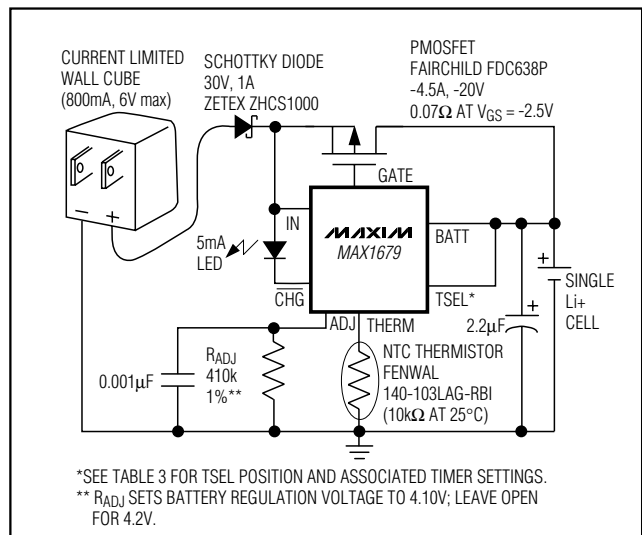

Figure 4. Application Circuit Including LED, Thermistor, and Reverse-Current Protection Diode

# Single-Cell Li+ Battery Charger for Current-Limited Supply

Table 3. Timer Option (TSEL) Definitions

TSEL CONNECTION	RECOMMENDED CHARGE RATE	FAST-CHARGE TIME LIMIT (minutes)	TOTAL CHARGE TIME LIMIT (hours)	MIN ON/OFF TIME (IN TOP-OFF) (ms)	ON/OFF DUTY CYCLE FOR DONE INDICATION
BATT	1.5C	55	2.8	70	1/256
ADJ	1C	75	3.75	140	1/128
GND	<1C	Off	6.25	280	1/64

### Selecting Maximum Charge Time

As a safety feature, fast-charging and pulsed top-off charging will stop if their respective counters time out. The MAX1679 offers a choice of three timeout periods set by TSEL (Table 3). In Table 3, C represents the nominal capacity of the battery cell in ampere hours.

Both timers begin upon entering the fast-charge state. The fast-charge timer is disabled upon leaving fast-charge; the total charge timer continues through top-off but is disabled in the done state.

### Selecting External Components

#### Power Supply

One reason the MAX1679 Li+ cell-charging solution is so compact and simple is that the charging current is set by the external power source, not by the MAX1679 charging circuit. The PMOS FET in this application circuit is either on or off, allowing the source to be directly connected to the cell or completely disconnected. Therefore, it is very important to choose a power supply with current limiting. In most applications, this will be a small “wall cube” switching converter with an output voltage limit of about 5V or 6V, which is advertised as “current-limited” or “constant current.”

#### PMOS Switch

The PMOS FET is used to switch the current-limited source on and off into the Li+ cell. Because of the intentionally slow switching times and limited slew rate, the MAX1679 is not particular about the power FET it drives. Specifications to consider when choosing an appropriate FET are the minimum drain-source breakdown voltage, the minimum turn-on threshold voltage ( $V_{GS}$ ), and current handling and power-dissipation qualities. The minimum breakdown voltage ( $BV_{DS}$ ) must exceed the open-circuit voltage of the wall cube by at least 25%. Note that this open-circuit voltage may be twice as high as the specified output voltage, depending on the converter type.

### Thermistor

The intent of THERM is to inhibit fast-charging the cell when it is too cold or too hot ( $+2.5^{\circ}\text{C} \leq T_{OK} \leq 47.5^{\circ}\text{C}$ ), using an external thermistor. THERM time multiplexes two sense currents to test for both hot and cold qualification. The thermistor should be  $10\text{k}\Omega$  at  $+25^{\circ}\text{C}$  and have a negative temperature coefficient (NTC); the THERM pin expects  $3.97\text{k}\Omega$  at  $+47.5^{\circ}\text{C}$  and  $28.7\text{k}\Omega$  at  $+2.5^{\circ}\text{C}$ . Connect the thermistor between THERM and GND. If no temperature qualification is desired, replace the thermistor with a  $10\text{k}\Omega$  resistor. Thermistors by Philips (22322-640-63103), Cornerstone Sensors (T101D103-CA), and Fenwal Electronics (140-103LAG-RB1) work well.

### Bypass Capacitors

Bypass the ADJ pin with a  $0.001\mu\text{F}$  ceramic capacitor. Bypass BATT with a capacitor with a value of at least  $1.5\mu\text{F}$  per amp of charge current. The MAX1679 has a built-in protection feature that prevents BATT from rising above 5.5V. The device recognizes a rapid rise at BATT, indicating that the cell is being removed with the FET on. A capacitor from BATT to GND that's too small does not give the MAX1679 adequate time to shut off the FET. BATT may then rise above 6V (towards the open-circuit source voltage), violating the absolute maximum rating and damaging the device.

In applications where the cell is removable, very large capacitance values make it increasingly difficult to identify momentary cell removal events and may increase transient currents when the cell is replaced. Therefore, values in excess of  $100\mu\text{F}$  should be avoided in those cases. For best system performance, at least  $0.47\mu\text{F}$  of the total capacitance should be low-ESR ceramic.

# Single-Cell Li+ Battery Charger for Current-Limited Supply

## **Layout Guidelines**

The MAX1679 controls the GATE slew rate. The layout is not as sensitive to noise as a high-frequency switching regulator. In addition, since the cell voltage is sensed both during and between high-current pulses, the system is insensitive to ground drops. However, Maxim recommends establishing good grounding areas and large traces for high-current paths.

## **Chip Information**

TRANSISTOR COUNT: 4692  
SUBSTRATE CONNECTED TO GND

**MAX1679**

# Single-Cell Li+ Battery Charger for Current-Limited Supply

## Package Information

8LUMAXDLEPS

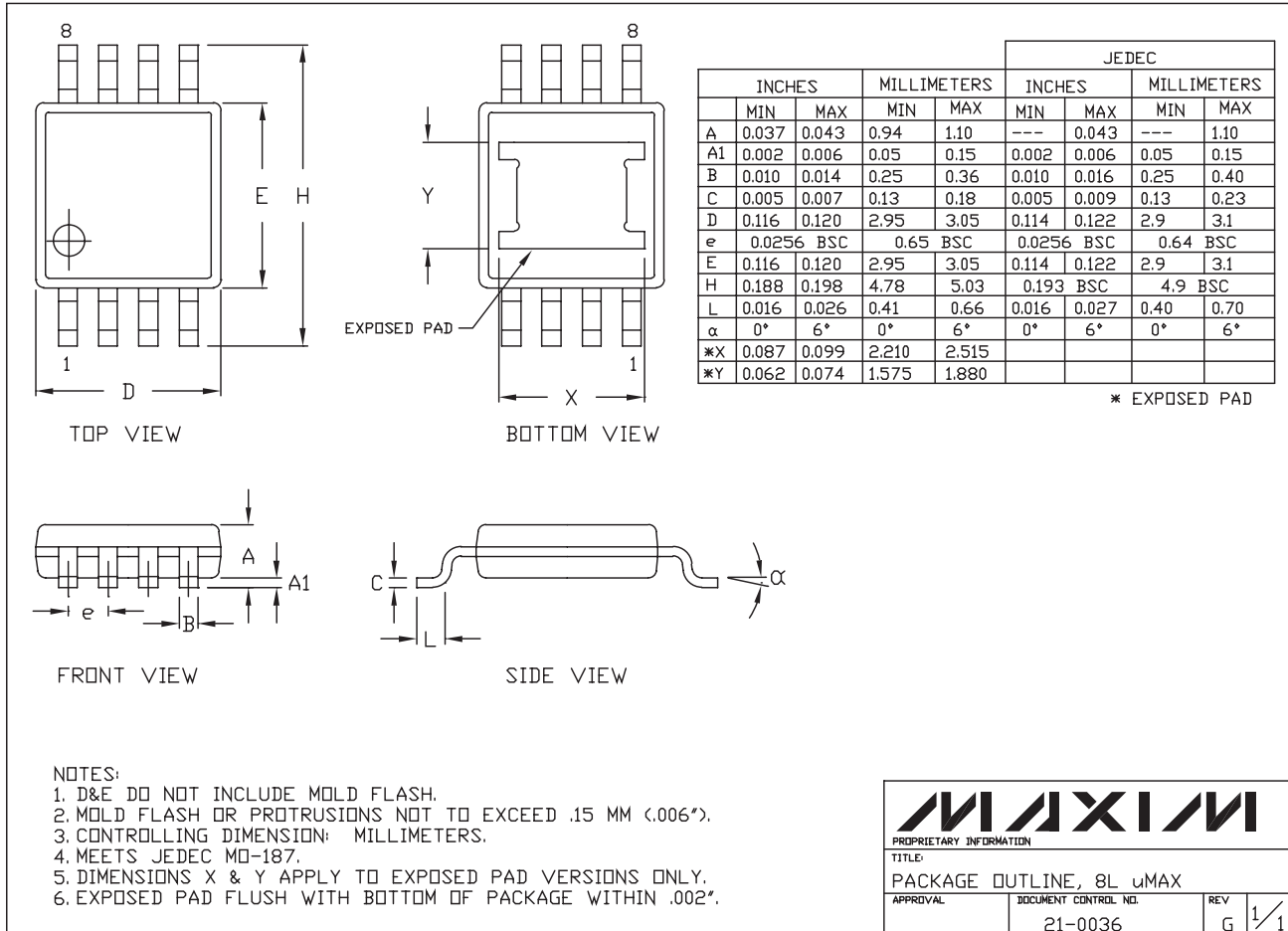

**Note:** The MAX1679 does not have an exposed pad.

Maxim cannot assume responsibility for use of any circuitry other than circuitry entirely embodied in a Maxim product. No circuit patent licenses are implied. Maxim reserves the right to change the circuitry and specifications without notice at any time.

12 \_\_\_\_\_ **Maxim Integrated Products, 120 San Gabriel Drive, Sunnyvale, CA 94086 408-737-7600**

Компания «Life Electronics» занимается поставками электронных компонентов импортного и отечественного производства от производителей и со складов крупных дистрибьюторов Европы, Америки и Азии.

С конца 2013 года компания активно расширяет линейку поставок компонентов по направлению коаксиальный кабель, кварцевые генераторы и конденсаторы (керамические, пленочные, электролитические), за счёт заключения дистрибьюторских договоров

Мы предлагаем:

- Конкурентоспособные цены и скидки постоянным клиентам.
- Специальные условия для постоянных клиентов.
- Подбор аналогов.
- Поставку компонентов в любых объемах, удовлетворяющих вашим потребностям.
- Приемлемые сроки поставки, возможна ускоренная поставка.
- Доставку товара в любую точку России и стран СНГ.
- Комплексную поставку.
- Работу по проектам и поставку образцов.
- Формирование склада под заказчика.
- Сертификаты соответствия на поставляемую продукцию (по желанию клиента).
- Тестирование поставляемой продукции.
- Поставку компонентов, требующих военную и космическую приемку.
- Входной контроль качества.
- Наличие сертификата ISO.

В составе нашей компании организован Конструкторский отдел, призванный помогать разработчикам, и инженерам.

Конструкторский отдел помогает осуществить:

- Регистрацию проекта у производителя компонентов.
- Техническую поддержку проекта.
- Защиту от снятия компонента с производства.
- Оценку стоимости проекта по компонентам.
- Изготовление тестовой платы монтаж и пусконаладочные работы.



Тел: +7 (812) 336 43 04 (многоканальный)  
Email: [org@lifeelectronics.ru](mailto:org@lifeelectronics.ru)