



4D SYSTEMS

TURNING TECHNOLOGY INTO ART

4.3" Embedded SPI Display

4DLCD-FT843

Powered by the FTDI FT800 Video Engine

DATASHEET

Document Date: 8th January 2014

Document Revision: 1.2

Contents

1. Description	3
2. Features	3
3. Display Flex Pin Out and Dimensions	4
4. Hardware Interface Pins	5
4.1. Pin Detail	5
4.2. Connection Detail.....	6
5. Mechanical Dimensions	7
6. Audio Filter and Amplifier Reference Circuit	8
7. Specifications and Ratings	9
8. Legal Notice	10
9. Contact Information	10

1. Description

The 4DLCD-FT843 is an embedded SPI display from 4D Systems, featuring a 4.3" resistive touch display with an integrated FTDI FT800 Video Engine.

The 4DLCD-FT843 is a powerful SPI Display which enables a SPI host to be connected directly to the display, providing a powerful set of graphics features to the host using the on board FTDI FT800 Video Engine.

This display provides 4 in one functionality, a 4.3" TFT LCD Display, Audio with amplifier enable, and Resistive Touch screen and an integrated Video Engine. This combination built directly into the screen allows for simple integration into a number of applications.

The FT800 Video Engine runs the FTDI version of EVE (Embedded Video Engine), which targets high quality graphics displays with Widget support, designed to offload the Host Processor and provide a variety of graphics features.

4D Systems has designed an Arduino Compatible Shield nicknamed ADAM (Arduino Display Adaptor Module) to interface with the EVE driven 4DLCD-FT843 Display, along with a simple breakout board (4DLCD-FT843-Breakout) to attach to a generic host or breadboard. Please refer to their product page on the 4D Systems website, and associated Documentation.

All software support for the 4DLCD-FT843 Display is provided directly from FTDI. FTDI also write and supply the libraries and demos for this shield/display combo. Hardware support is provided by 4D Systems.



ADAM Shield for Arduino



4DLCD-FT843 Breakout

2. Features

- 4.3" TFT LCD Transmissive Display with 480x272 Resolution, and 262K Colours
- 4 Wire Resistive Touch screen
- Mono PWM Audio output with separate amplifier enable, designed to be connected directly to a simple filter and amplifier circuit.
- On board FTDI FT800 Video Engine
- SPI Interface to Host Processor/Controller, up to 30Mhz (Mode 0 only)
- Standard 10 way 0.5mm pitch FPC ribbon which carries SPI, Audio, I/O and Power to/from the Display.
- Programmable Interrupt Controller, with dedicate Interrupt pin to Host
- 64 voice polyphonic sound synthesizer
- PWM dimming control for LCD backlight
- Power mode control to put the FT800 into sleep and standby modes, with dedicated power down pin to Host
- Single 3.3V supply
- 3.3V SPI Bus, Audio Output and amplifier Enable, not 5V tolerant.
- Display Dimensions: 105.5 x 67.2 x 4.2mm (Not including flex)
- Flex length from base of display: 57.51mm
- Viewing Area: 95.04 x 53.86mm
- Touch Area: 96.7 x 55.5mm
- Weight: 60gm
- RoHS Compliant
- CE Compliant

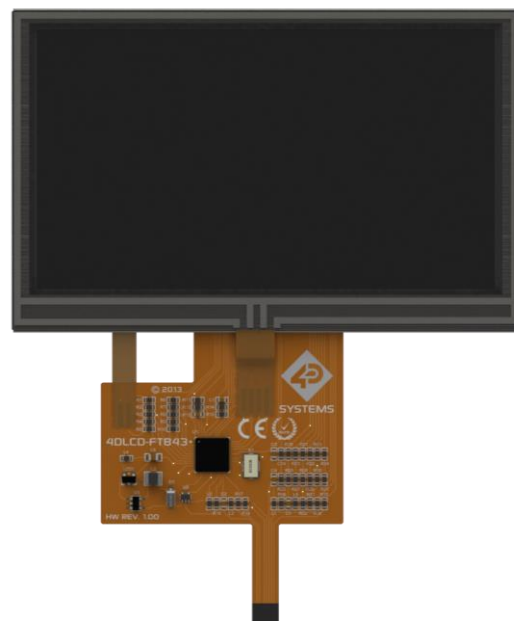

4DLCD-FT843 Display

3. Display Flex Pin Out and Dimensions

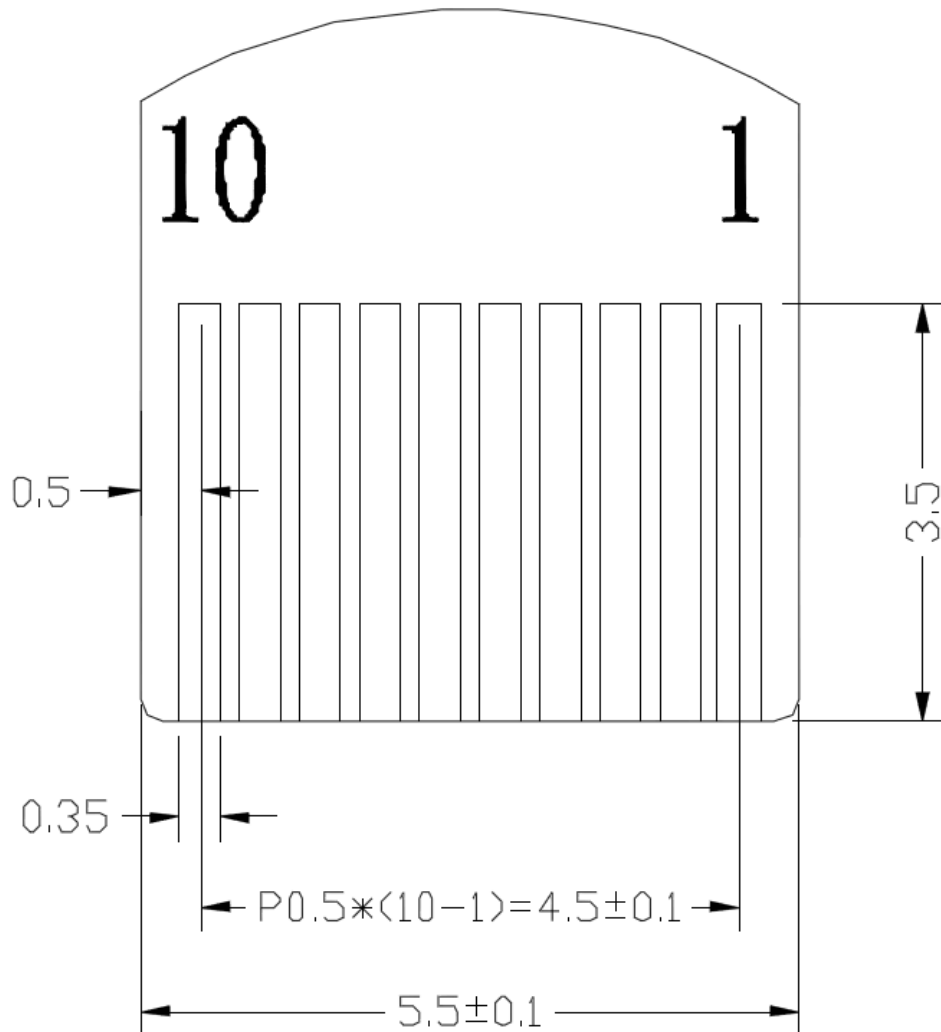

Please note: This is the **BACK** view of the Display FPC, opposite side to the components on the Flex

Flex Pin Out			
Pin	Symbol	I/O	Description
1	3.3V	P	3.3V Power Supply for Display Module and FT800 Video Engine. Voltage Input minimum is 3.0V and maximum is 3.6V, 3.3V is recommended.
2	SCK	I	SPI Clock Input from Host
3	MISO	O	SPI Data Output to Host
4	MOSI	I	SPI Data Input from Host
5	CS	I	SPI Chip Select from Host
6	INT	O	Configurable Interrupt to Host
7	PD	I	Power Down Input from Host
8	AUDIO_SHDN	O	Audio Shutdown Output to Amplifier
9	AUDIO_OUT	O	Audio Output PWM, requires simple filter and then to Amplifier
10	GND	P	Power Ground

I = Input, O = Output, P = Power

4. Hardware Interface Pins

The 4DLCD-FT843 Display features 10 physical pins on the flex. This section describes each in detail.

4.1. Pin Detail

Pin 1: 3.3V - Power Input

This is the main power input pin for the display. It powers not only the display logic itself, but also the FT800 Video Engine on board the flex, along with the backlight for the 4.3" display. The recommended voltage is 3.3V, however the display can be powered as low as 3.0V and as high as 3.6V. It is however highly recommended to stay at 3.3V for best results. This also enables interfacing with a 3.3V host processor easier, along with the interface to a micro-SD or SD card, which is also recommended to be at 3.3V.

Pin 2: SCK – SPI Clock

This is the Clock Input for the SPI Bus which comes from the host. This is 3.3V logic and is not 5V tolerant, please only connect 3.3V compatible devices to this pin. The FT800 can run up to a maximum of 30Mhz on the SPI Bus.

Pin 3: MISO – SPI Data Output

This is the SPI Data Output from the Display, which goes to the Host processor. This is 3.3V logic and is not 5V tolerant, please only connect 3.3V compatible devices to this pin.

Pin 4: MOSI – SPI Data Input

This is the SPI Data Input for the Display, which comes from the Host processor. This is 3.3V logic and is not 5V tolerant, please only connect 3.3V compatible devices to this pin.

Pin 5: CS – SPI Chip Select Input

This is the SPI Chip Select Input for the Display, which comes from the Host processor. This is 3.3V logic and is not 5V tolerant, please only connect 3.3V compatible devices to this pin.

Pin 6: INT – Configurable Interrupt Output

This is the Configurable Interrupt Output from the display, which can be configured to be trigger by a number of events, and is used to interrupt the Host Processor when the interrupt event occurs.

This is an Open Drain output, which is pulled high to 3.3V by the display module, and is Active Low.

Please refer to the FT800 Datasheet from FTDI, which is linked from the 4DLCD-FT843 Product Page on the 4D Systems website, for more information.

Pin 7: PD – Power Down Input

This is the Power Down Input for the Display, which can be triggered by the Host Processor if the display is required to be powered down, either from a standby state or from its active state.

This is pulled high to 3.3V by the display module, and is Active Low.

Holding this pin low for >5mS will cause the FT800 Video Engine to shut down and go into a powered down state. Releasing this low or driving the pin High will cause the display to start up again.

It is also possible to reset the display using this pin, by driving it low for 5mS and then high again.

Please refer to the FT800 Datasheet from FTDI, which is linked from the 4DLCD-FT843 Product Page on the 4D Systems website, for more information.

Pin 8: AUDIO_SHDN – Audio Shutdown

This is the Audio Shutdown output from the FT800 Video Engine, which is designed to enable/disable an external audio amplifier based on the events occurring on the FT800.

This pin is actually the GPIO01 General Purpose I/O on the FT800, so could be used for an alternative function if required.

Please refer to the FT800 Datasheet from FTDI, which is linked from the 4DLCD-FT843 Product Page on the 4D Systems website, for more information.

Pin 9: AUDIO_OUT – Audio Output

This is the Audio Output from the FT800 Video Engine, which is a Push/Pull PWM Output capable of Source/Sink of 16mA of current.

This pin is designed to be passed into a simple filter circuit and then passed to an amplifier for best results. Please refer to the example schematic in Section 6 which provides the recommended circuit to connect to this pin.

Please refer to the FT800 Datasheet from FTDI, which is linked from the 4DLCD-FT843 Product Page on the 4D Systems website, for more information.

Pin 10: GND – Power Ground

This is the Power Ground for the 4DLCD-FT843 Display. This should be connected to the GND associated with the Pin 1 3.3V Power Input pin.

4.2. Connection Detail

The 4DLCD-FT843 Display features a 10 way flexible FPC, which is designed to connect into a 10 way FPC connector on a PCB.

Please note, the display FPC is fragile and contains many components, so the main body of the FPC should not be bent or subjected to excessive forces or be twisted, else the flex may be damaged and the display will no longer function correctly.

Out of the main body of the flex, is a thin portion which contains the 10 signals, which connects to the target PCB's FPC connector. This is also fragile and should be treated with care, it should not be subjected to excessive bending or twisting else it may be damaged.

The 4DLCD-FT843 Display is designed to be easily connected to a target host PCB. 4D Systems offers two products which may be useful.

One is an Arduino Sheild nicknamed ADAM (Arduino Display Adaptor Module), which is designed to connect directly to an Arduino, and features a 10 way FPC connector to connect the 4DLCD-FT843 Display, along with a micro-SD socket and associated jumpers.

The other product is a simple breakout board, which features a 10 way FPC connector, and then a single 2.54mm pitch row of male pins to plug directly into a breadboard or into a host PCB.

For detail on these products, please refer to the respective product pages on the 4D Systems website.

The 4DLCD-FT843 Display connects to a target Host Processor / MCU using a 3.3V SPI Bus, and also features an Interrupt Pin and Shutdown Pin for applications which can make use of them.

The Display has the ability to generate PWM audio, both Mono PCM and Polyphonic MIDI, which exits the display module via the 10 way FPC, and should then be fed into a simple filter and amplifier circuit. This circuit is shown in Section 6.0 and should be treated as the recommended circuit, however alternative circuits are also possible.

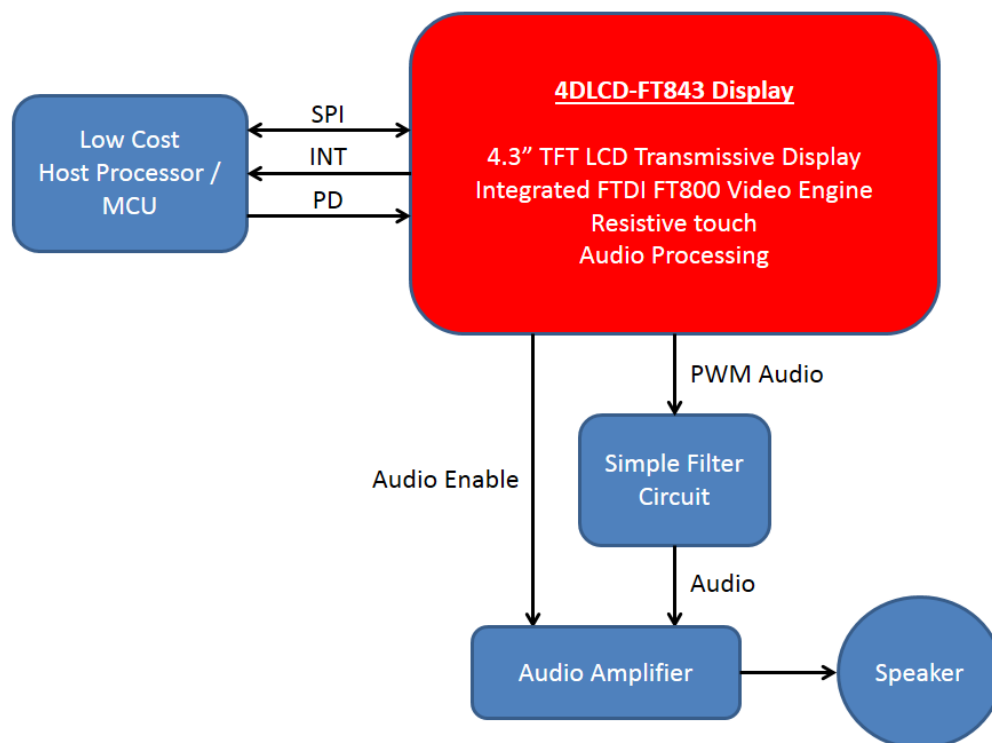

5. Mechanical Dimensions

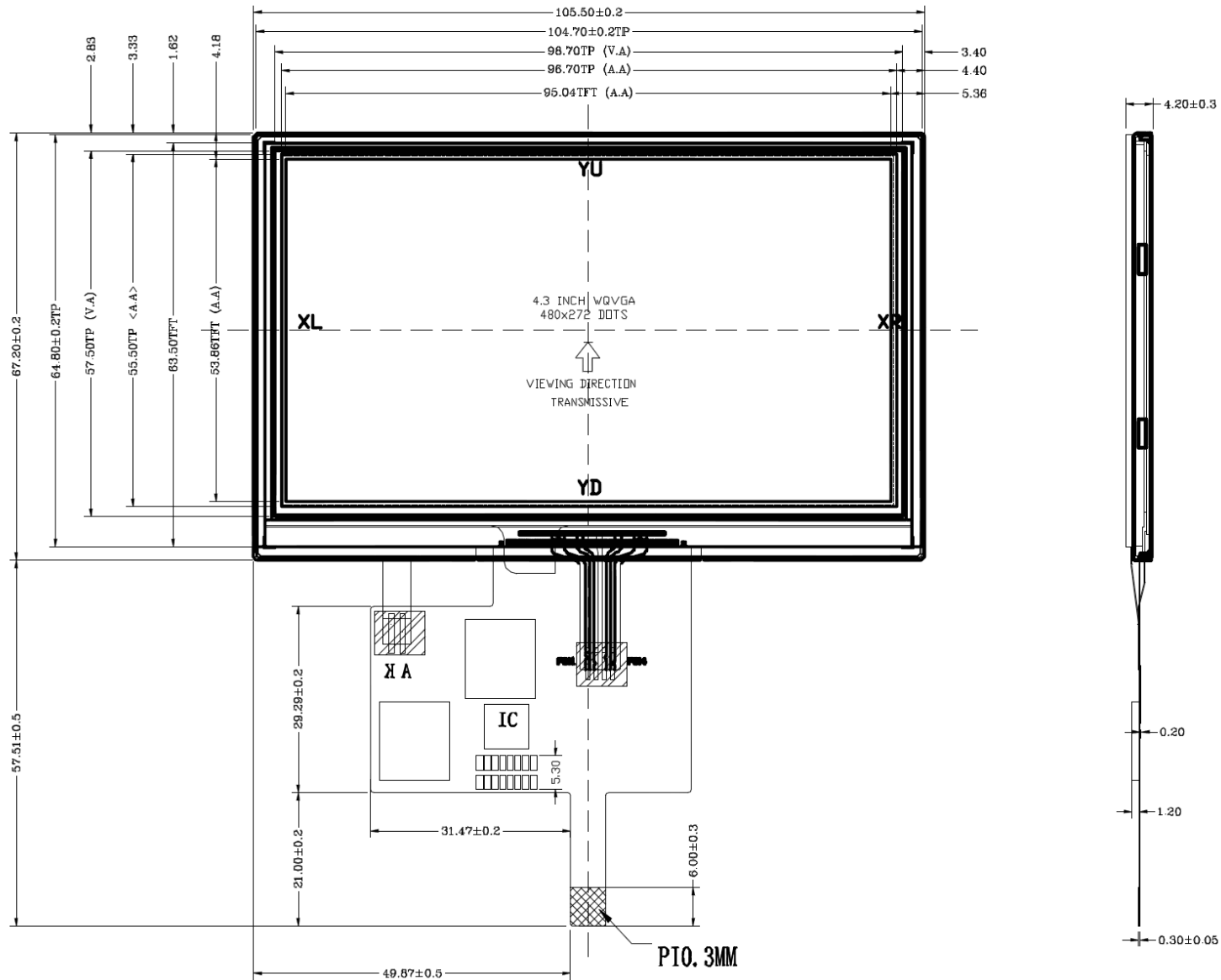

6. Audio Filter and Amplifier Reference Circuit

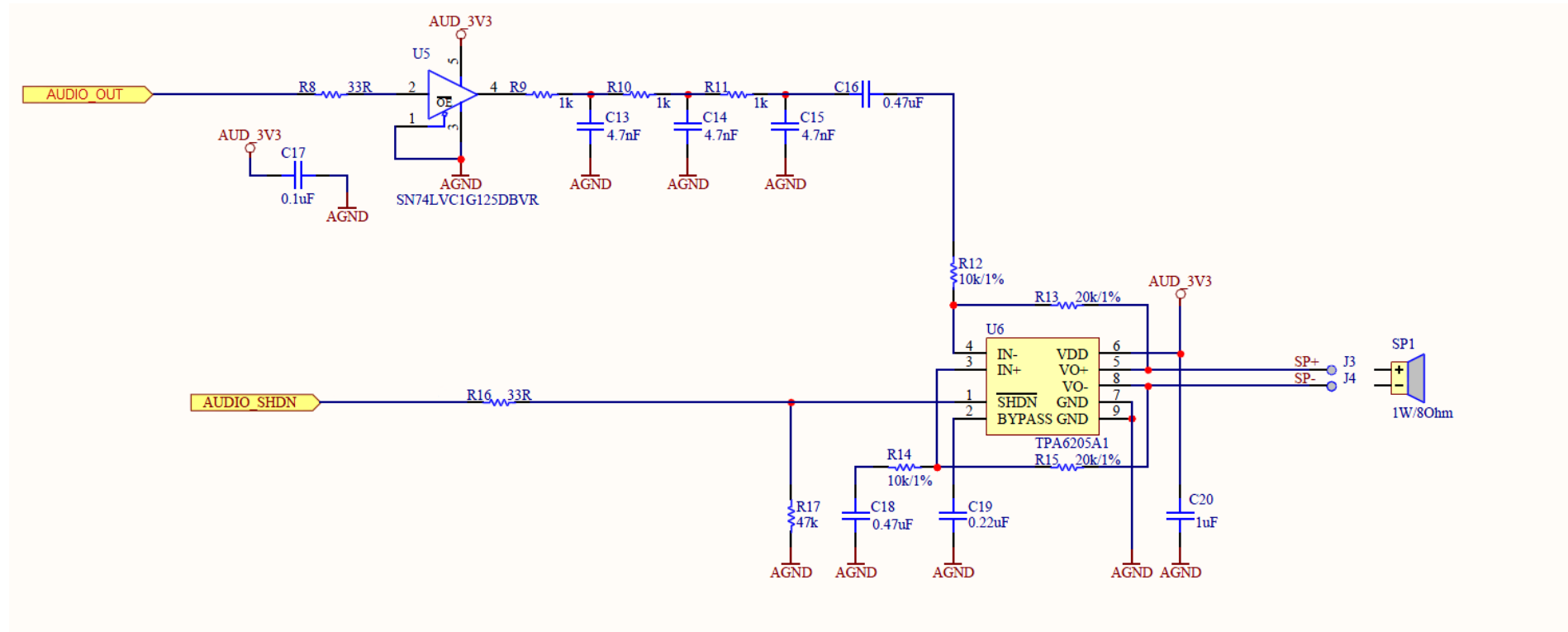

Please note this circuit is not included on any hardware from 4D Systems. This is a reference schematic from FTDI, which can be used to successfully filter and amplify the audio signals coming from the FT800, and therefore 4DLCD-FT843 Display.

7. Specifications and Ratings

RECOMMENDED OPERATING CONDITIONS					
Parameter	Conditions	Min	Typ	Max	Units
Supply Voltage (VCC)		3.0V	3.3V	3.6V	V
Operating Temperature		-10	--	+70	°C
Typical LCD Life		--	20000	--	Hours
Current Usage	Dependant on usage, audio, brightness, processing, GPIO	--	210	--	mA

TOUCH SCREEN CHARACTERISTICS					
Parameter	Conditions	Min	Typ	Max	Units
Linearity		--	--	<1.5	%
Terminal Resistance X	X film side	200	--	850	Ohm
Terminal Resistance Y	Y film side	150	--	580	Ohm
Durability – Scratch Test	Stylus Pen or Finger Sliding	100	--	--	K
Durability – Tap Test	Stylus Pen or Finger Press	1	--	--	Million
Transparency		--	80	--	%

OPTICAL CHARACTERISTICS						
Parameter		Condition	Min	Typ	Max	Units
Contrast ratio (Centre point)		Back-light On	450	500	--	--
Luminance of white (Centre point)			400	--	--	Cd/m ²
White Uniformity			--	80	--	%
Response Time	Rising + Falling (Tr + Tf)		--	45	--	ms
Viewing Angle	Vertical above Centre	Contrast Ratio \geq 10	50		Degrees	
	Vertical below Centre		70			
	Horizontal Left of Centre		70			
	Horizontal Right of Centre		70			

NOTE: Please note that all specifications listed are for the current production versions of this Intelligent Display Module.

ORDERING INFORMATION
Order Code: 4DLCD-FT843
Packaging: Module sealed in antistatic foam padded 4D Systems Box

8. Legal Notice

Proprietary Information

The information contained in this document is the property of 4D Systems Pty. Ltd. and may be the subject of patents pending or granted, and must not be copied or disclosed without prior written permission.

4D Systems endeavours to ensure that the information in this document is correct and fairly stated but does not accept liability for any error or omission. The development of 4D Systems products and services is continuous and published information may not be up to date. It is important to check the current position with 4D Systems. 4D Systems reserves the right to modify, update or make changes to Specifications or written material without prior notice at any time.

All trademarks belong to their respective owners and are recognised and acknowledged.

Disclaimer of Warranties & Limitation of Liability

4D Systems makes no warranty, either expressed or implied with respect to any product, and specifically disclaims all other warranties, including, without limitation, warranties for merchantability, non-infringement and fitness for any particular purpose.

Information contained in this publication regarding device applications and the like is provided only for your convenience and may be superseded by updates. It is your responsibility to ensure that your application meets with your specifications.

Images and graphics used throughout this document are for illustrative purposes only. All images and graphics used are possible to be displayed on the 4D Systems range of products, however the quality may vary.

In no event shall 4D Systems be liable to the buyer or to any third party for any indirect, incidental, special, consequential, punitive or exemplary damages (including without limitation lost profits, lost savings, or loss of business opportunity) arising out of or relating to any product or service provided or to be provided by 4D Systems, or the use or inability to use the same, even if 4D Systems has been advised of the possibility of such damages.

4D Systems products are not fault tolerant nor designed, manufactured or intended for use or resale as on line control equipment in hazardous environments requiring fail – safe performance, such as in the operation of nuclear facilities, aircraft navigation or communication systems, air traffic control, direct life support machines or weapons systems in which the failure of the product could lead directly to death, personal injury or severe physical or environmental damage ('High Risk Activities'). 4D Systems and its suppliers specifically disclaim any expressed or implied warranty of fitness for High Risk Activities.

Use of 4D Systems' products and devices in 'High Risk Activities' and in any other application is entirely at the buyer's risk, and the buyer agrees to defend, indemnify and hold harmless 4D Systems from any and all damages, claims, suits, or expenses resulting from such use. No licenses are conveyed, implicitly or otherwise, under any 4D Systems intellectual property rights.

9. Contact Information

For Technical Support: support@4dsystems.com.au

For Sales Support: sales@4dsystems.com.au

Website: www.4dsystems.com.au

Copyright 4D Systems Pty. Ltd. 2000-2014.

Компания «Life Electronics» занимается поставками электронных компонентов импортного и отечественного производства от производителей и со складов крупных дистрибьюторов Европы, Америки и Азии.

С конца 2013 года компания активно расширяет линейку поставок компонентов по направлению коаксиальный кабель, кварцевые генераторы и конденсаторы (керамические, пленочные, электролитические), за счёт заключения дистрибьюторских договоров

Мы предлагаем:

- Конкуренеспособные цены и скидки постоянным клиентам.
- Специальные условия для постоянных клиентов.
- Подбор аналогов.
- Поставку компонентов в любых объемах, удовлетворяющих вашим потребностям.
- Приемлемые сроки поставки, возможна ускоренная поставка.
- Доставку товара в любую точку России и стран СНГ.
- Комплексную поставку.
- Работу по проектам и поставку образцов.
- Формирование склада под заказчика.
- Сертификаты соответствия на поставляемую продукцию (по желанию клиента).
- Тестирование поставляемой продукции.
- Поставку компонентов, требующих военную и космическую приемку.
- Входной контроль качества.
- Наличие сертификата ISO.

В составе нашей компании организован Конструкторский отдел, призванный помогать разработчикам, и инженерам.

Конструкторский отдел помогает осуществить:

- Регистрацию проекта у производителя компонентов.
- Техническую поддержку проекта.
- Защиту от снятия компонента с производства.
- Оценку стоимости проекта по компонентам.
- Изготовление тестовой платы монтаж и пусконаладочные работы.



Тел: +7 (812) 336 43 04 (многоканальный)

Email: org@lifeelectronics.ru