



BIPOLAR ANALOG INTEGRATED CIRCUIT UPC2757TB / UPC2758TB

3 V, SUPER MINIMOLD SI MMIC DOWNCONVERTER

FEATURES

- **HIGH-DENSITY SURFACE MOUNTING:**
6 pin super minimold or SOT-363 package
- **WIDEBAND OPERATION:**
RF = 0.1 GHz to 2.0 GHz
IF = 20 MHz to 300 MHz
- **BUILT-IN POWER SAVE FUNCTION**
- **SUPPLY VOLTAGE:** $V_{CC} = 2.7$ TO 3.3 V

DESCRIPTION

The UPC2757TB and UPC2758TB are silicon RFICs manufactured using the NESAT™ III process. The devices consist of a mixer, an IF amplifier and an LO buffer amplifier. These devices are suitable as 1st IF downconverters for the receiver stage of cellular and other wireless systems. The UPC2757TB is designed for low power consumption while the UPC2758TB is designed for low distortion. The UPC2757TB/58TB are pin compatible and have comparable performance to the larger UPC2757T/58T, so they are suitable for use as a replacement to help reduce system size. The IC is housed in a 6 pin super minimold or SOT-363 package.

Stringent quality assurance and test procedures ensure the highest reliability and performance.

CONVERSION GAIN vs. LO FREQUENCY

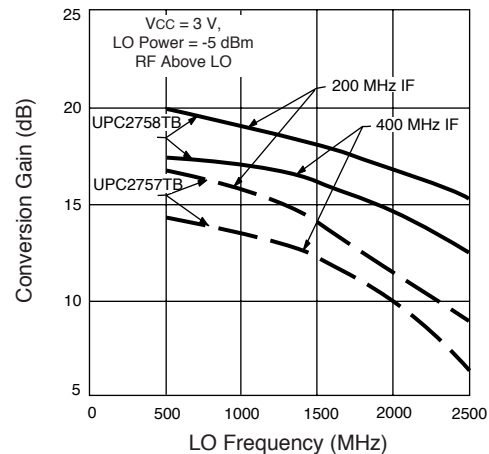

ELECTRICAL CHARACTERISTICS (TA = 25°C, VCC = VPS = 3.0 V, PLO = -10 dBm)

PART NUMBER PACKAGE OUTLINE			UPC2757TB S06			UPC2758TB S06		
SYMBOLS	PARAMETERS AND CONDITIONS	UNITS	MIN	TYP	MAX	MIN	TYP	MAX
ICC	Circuit Current, VPS = 3 V VPS = 0.5 V	mA μA	3.7	5.6 0.1	7.7	6.6	11 0.1	14.8
fRF	RF Operating Frequency Range (The conversion gain at fRF is not more than 3 dB down from the gain at fRF = 800 MHz, fIF = 130 MHz)	GHz	0.1		2.0	0.1		2.0
fIF	IF Operating Frequency Range (The conversion gain at fIF is not more than 3 dB down from the gain at fRF = 800 MHz, fIF = 130 MHz)	MHz	20		300	20		300
CG	Conversion Gain ¹ , fRF = 800 MHz, fIF = 130 MHz fRF = 2.0 GHz, fIF = 250 MHz	dB dB	12 10	15 13	18 16	16 14	19 17	22 20
NF	Noise Figure, SSB, fRF = 800 MHz, fIF = 130 MHz fRF = 2.0 GHz, fIF = 250 MHz	dB dB		10 13	13 16		9 13	12 15
PSAT	Saturated Output Power ² , fRF = 800 MHz, fIF = 100 MHz fRF = 2.0 GHz, fIF = 250 MHz	dBm dBm	-11 -11	-3 -8		-7 -7	+1 -4	
P1dB	Output Power at 1dB compression point, fRF = 800 MHz fIF = 100 MHz	dBm		-8			-3.5	
OIP3	Output 3rd Order Intercept Point, (SSB) PLO = -10 dBm fRF = 0.8~2.0 GHz, fIF = 100 MHz	dBm		+5			+11	
ISOL	LO Leakage, fLO = 0.8 ~2.0 GHz	at RF pin dBm at IF pin dBm		-35 -23			-30 -15	
RTH (J-A)	Thermal Resistance (Junction to Ambient) Mounted on a 50 x 50 x 1.6 mm epoxy glass PWB	°C/W			325			325

Notes:

1. PRF = -40 dBm.
2. PRF = -10 dBm.

UPC2757TB, UPC2758TB

ABSOLUTE MAXIMUM RATINGS¹ (T_A = 25°C)

SYMBOLS	PARAMETERS	UNITS	RATINGS
V _{CC} , V _{PS}	Supply Voltage	V	5.5
P _T	Total Power Dissipation ²	mW	200
T _{OP}	Operating Temperature	°C	-40 to +85
T _{STG}	Storage Temperature	°C	-55 to +150

Notes:

1. Operation in excess of any one of these parameters may result in permanent damage.
2. Mounted on a 50 x 50 x 1.6 mm epoxy glass PWB (T_A = +85°C).

RECOMMENDED OPERATING CONDITIONS

SYMBOLS	PARAMETERS	UNITS	MIN	TYP	MAX
V _{CC}	Supply Voltage	V	2.7	3.0	3.3
T _{OP}	Operating Temperature	°C	-40	+25	+85
P _{LO}	LO Input Level	dBm	-15	-10	0

TEST CIRCUIT/BLOCK DIAGRAM

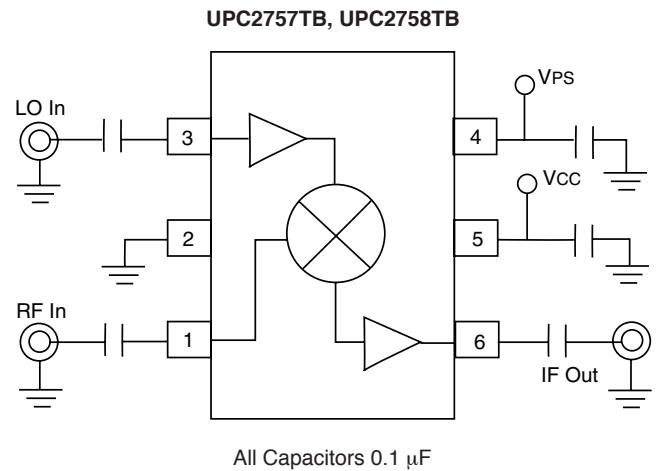

PIN DESCRIPTION

Pin No.	Pin Name	Applied Voltage (V)	Pin Voltage (V)	Description	Internal Equivalent Circuit						
1	RFIN	—	1.2	Signal input pin to double balanced mixer. This pin must be coupled to the signal source with a blocking capacitor.							
2	GND	0	—	Ground pin. This pin should be connected to system ground with minimum inductance. Ground pattern on the board should be formed as wide as possible.							
3	LOIN	—	1.3	LO input pin. The LO buffer is designed as a differential amplifier. Recommended input level is -15 to 0 dBm.							
4	VPS	VCC / GND	—	Power save control pin can control the On/Sleep state with bias as follows: <table border="1" style="margin: 5px auto;"> <thead> <tr> <th>V_{PS} (V)</th> <th>STATE</th> </tr> </thead> <tbody> <tr> <td>≥2.5</td> <td>ON</td> </tr> <tr> <td>0 to 0.5</td> <td>SLEEP</td> </tr> </tbody> </table> Rise time/fall time using this pin is approximately 10 μs.	V _{PS} (V)	STATE	≥2.5	ON	0 to 0.5	SLEEP	
V _{PS} (V)	STATE										
≥2.5	ON										
0 to 0.5	SLEEP										
5	VCC	2.7 to 3.3	—	Power supply pin. This pin should be externally equipped with a bypass capacitor to minimize ground impedance.							
6	IFOUT	—	1.7	Output of single-ended push-pull IF buffer amplifier. This is an emitter-follower output with low impedance. This pin must be coupled to the next stage with a blocking capacitor.							

TYPICAL PERFORMANCE CURVES (TA = 25°C)

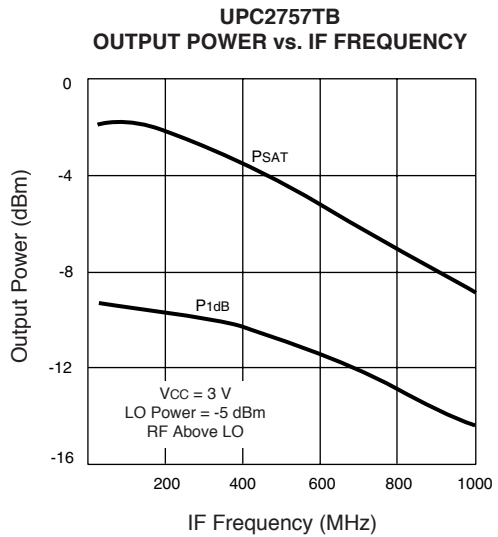
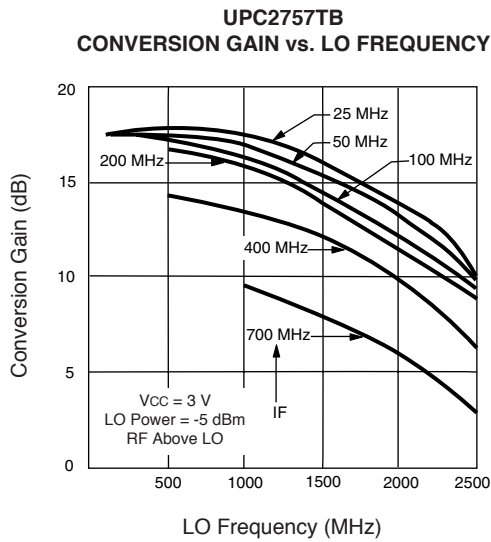
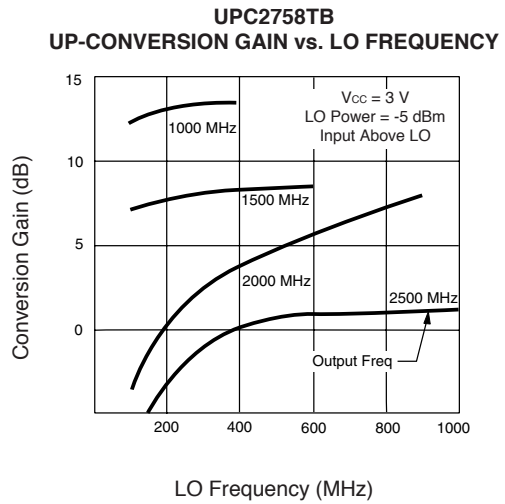
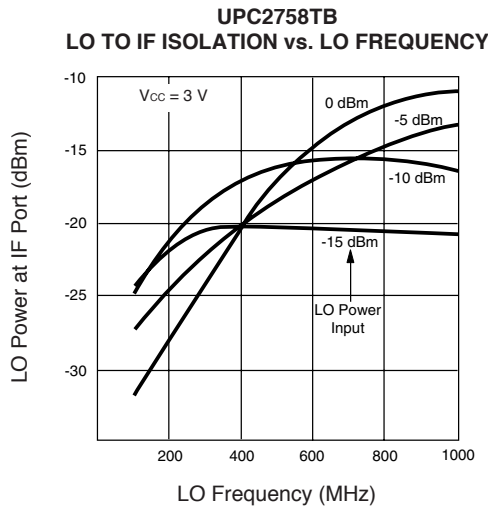
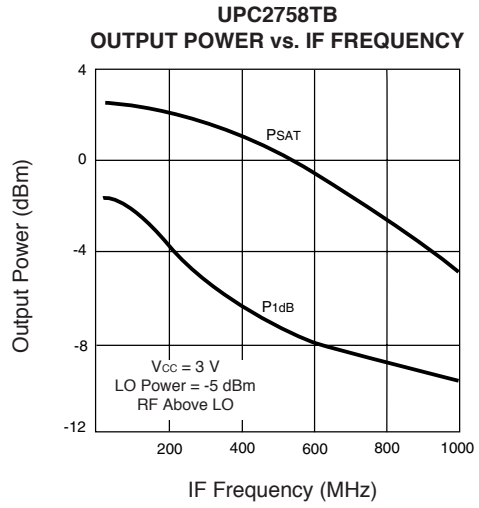
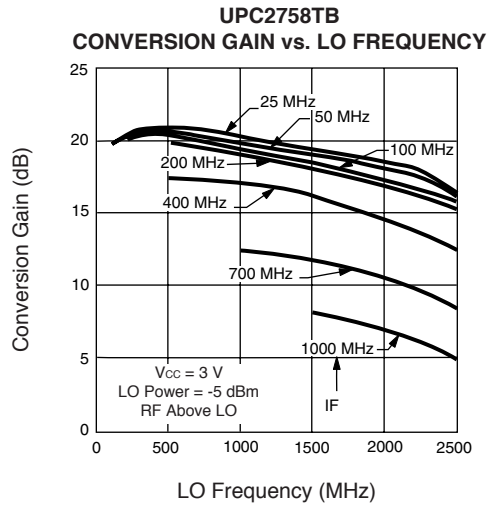

TYPICAL PERFORMANCE CURVES (T_A = 25°C)

UPC2757TB
LO TO IF ISOLATION vs. LO FREQUENCY

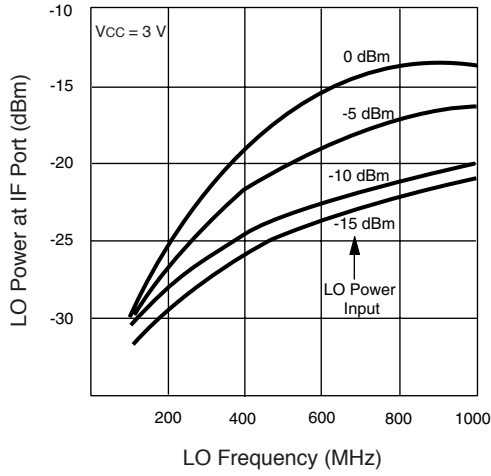

UPC2757TB
UP-CONVERSION GAIN vs. LO FREQUENCY

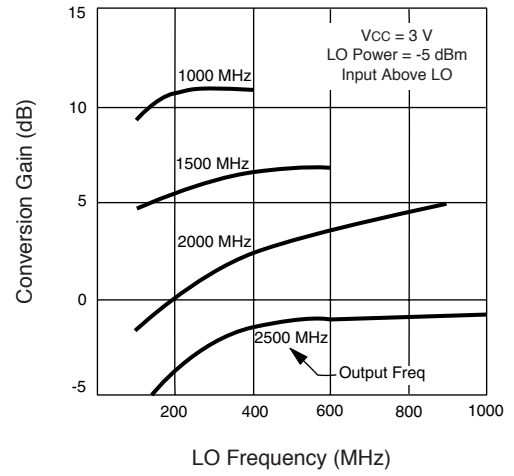

UPC2757TB
CONVERSION GAIN vs. LO FREQUENCY

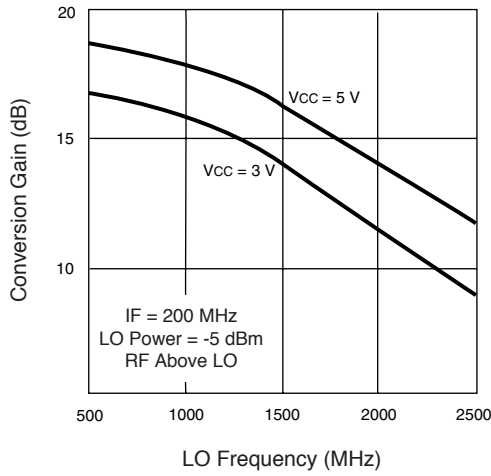

UPC2757TB
CONVERSION GAIN vs. LO POWER

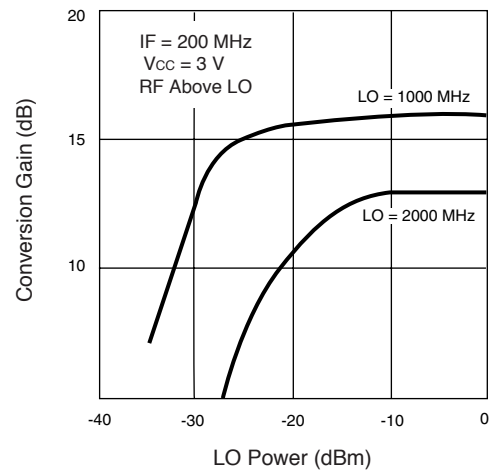

APPLICATION EXAMPLE

Digital Cellular Telephone

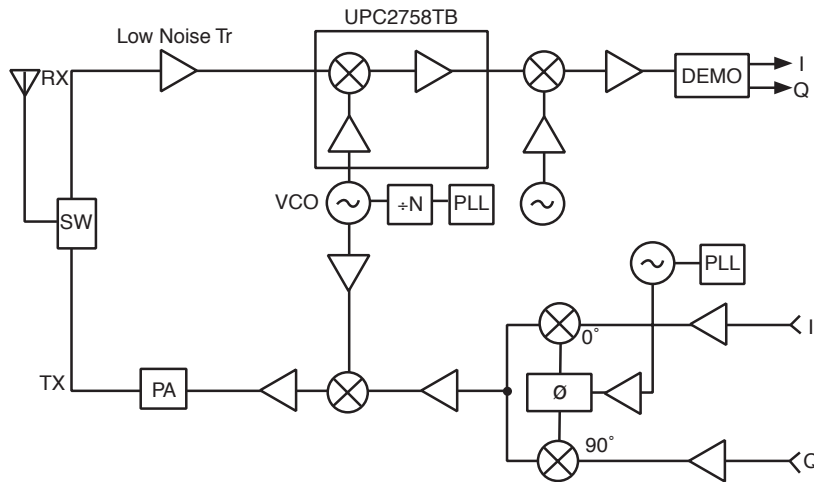

ORDERING INFORMATION

PART NUMBER	QTY
UPC2757TB-E3-A	3K/Reel
UPC2758TB-E3-A	3K/Reel

Note:
Embossed Tape, 8 mm wide,
Pins 1, 2, 3 are in tape pull-out direction.

OUTLINE DIMENSIONS

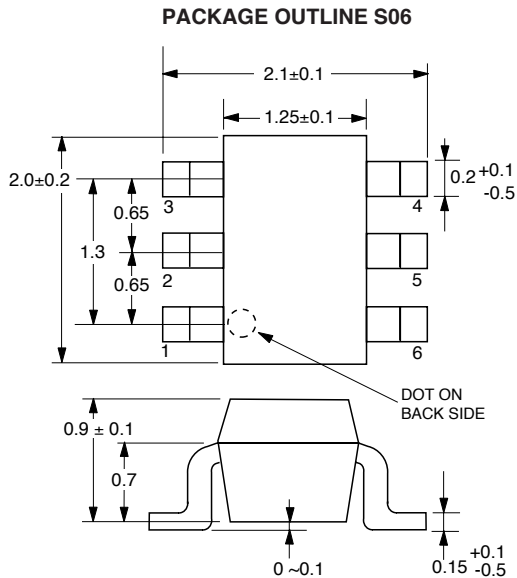

Note:
All dimensions are typical unless otherwise specified.

INTERNAL BLOCK DIAGRAM

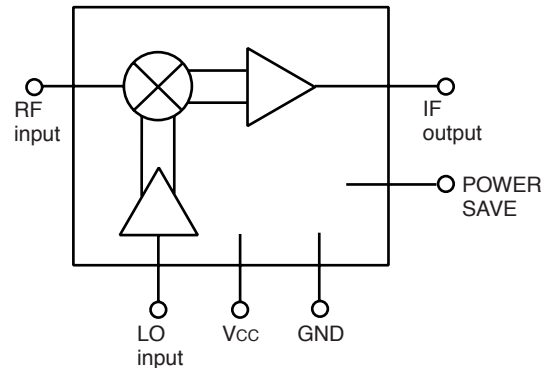

LEAD CONNECTIONS

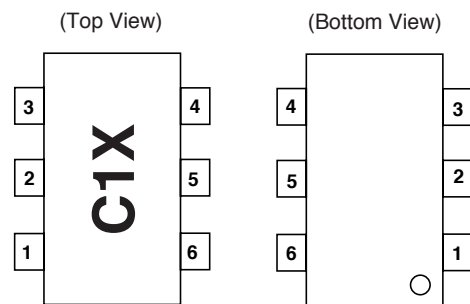

1. RF INPUT
2. GND
3. LO INPUT
4. PS
5. Vcc
6. IF OUTPUT

Note:
Package Markings:
C1X: UPC2757TB
C1Y: UPC2758TB

EXCLUSIVE NORTH AMERICAN AGENT FOR RF, MICROWAVE & OPTOELECTRONIC SEMICONDUCTORS

CEL CALIFORNIA EASTERN LABORATORIES • Headquarters • 4590 Patrick Henry Drive • Santa Clara, CA 95054-1817 • (408) 988-3500 • Telex 34-6393 • FAX (408) 988-0279
DATA SUBJECT TO CHANGE WITHOUT NOTICE

Internet: <http://WWW.CEL.COM>

10/24/2001

Компания «Life Electronics» занимается поставками электронных компонентов импортного и отечественного производства от производителей и со складов крупных дистрибьюторов Европы, Америки и Азии.

С конца 2013 года компания активно расширяет линейку поставок компонентов по направлению коаксиальный кабель, кварцевые генераторы и конденсаторы (керамические, пленочные, электролитические), за счёт заключения дистрибьюторских договоров

Мы предлагаем:

- Конкурентоспособные цены и скидки постоянным клиентам.
- Специальные условия для постоянных клиентов.
- Подбор аналогов.
- Поставку компонентов в любых объемах, удовлетворяющих вашим потребностям.
- Приемлемые сроки поставки, возможна ускоренная поставка.
- Доставку товара в любую точку России и стран СНГ.
- Комплексную поставку.
- Работу по проектам и поставку образцов.
- Формирование склада под заказчика.
- Сертификаты соответствия на поставляемую продукцию (по желанию клиента).
- Тестирование поставляемой продукции.
- Поставку компонентов, требующих военную и космическую приемку.
- Входной контроль качества.
- Наличие сертификата ISO.

В составе нашей компании организован Конструкторский отдел, призванный помогать разработчикам, и инженерам.

Конструкторский отдел помогает осуществить:

- Регистрацию проекта у производителя компонентов.
- Техническую поддержку проекта.
- Защиту от снятия компонента с производства.
- Оценку стоимости проекта по компонентам.
- Изготовление тестовой платы монтаж и пусконаладочные работы.



Тел: +7 (812) 336 43 04 (многоканальный)

Email: org@lifeelectronics.ru