

**TWO PHASE HALL-EFFECT SMART FAN MOTOR CONTROLLER**

NEW PRODUCT

**Description**

The AH2985 is a single-chip solution for driving two-coil brushless direct current (BLDC) fans and motors. The device includes a Hall-effect sensor, dynamic offset correction and two complementary open-drain output drivers with internal Zener diode protection. It is optimized for low start-up voltage.

To help protect the motor coils, the AH2985 provides Rotor Lock Protection which shuts down output drives if rotor lock is detected. The device automatically re-starts when the rotor lock is removed. Over temperature shutdown provides thermal protection for the device.

The AH2985 is available in TO94 package.

**Features**

- Single-Chip Solution
- Operating Voltage: 2.5V to 15V
- Built-in Hall Sensor and Input Amplifier
- Rotor Lock Protection (Lock Detection, Output Shutdown and Automatic re-Start)
- Built-in Reverse Voltage Protection Diode
- Built-in Zener Protection for Output Drivers
- Average Output Current up to 500mA
- Package: TO94
- "Green" Molding Compound
- **Totally Lead-Free & Fully RoHS Compliant (Notes 1 & 2)**
- **Halogen and Antimony Free. "Green" Device (Note 3)**

- Notes:
1. No purposely added lead. Fully EU Directive 2002/95/EC (RoHS) & 2011/65/EU (RoHS 2) compliant.
  2. See [http://www.diodes.com/quality/lead\\_free.html](http://www.diodes.com/quality/lead_free.html) for more information about Diodes Incorporated's definitions of Halogen- and Antimony-free, "Green" and Lead-free.
  3. Halogen- and Antimony-free "Green" products are defined as those which contain <900ppm bromine, <900ppm chlorine (<1500ppm total Br + Cl) and <1000ppm antimony compounds.

**Pin Assignments**

(Top View)

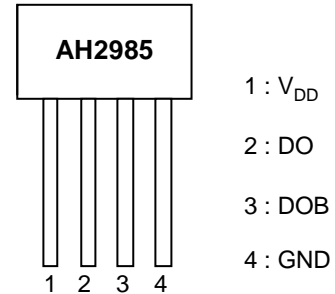

TO94

**Applications**

- Two-Coil BLDC Cooling Fans
- Low Voltage/ Low Power BLDC Motors

**Typical Applications Circuit (Note 4)**

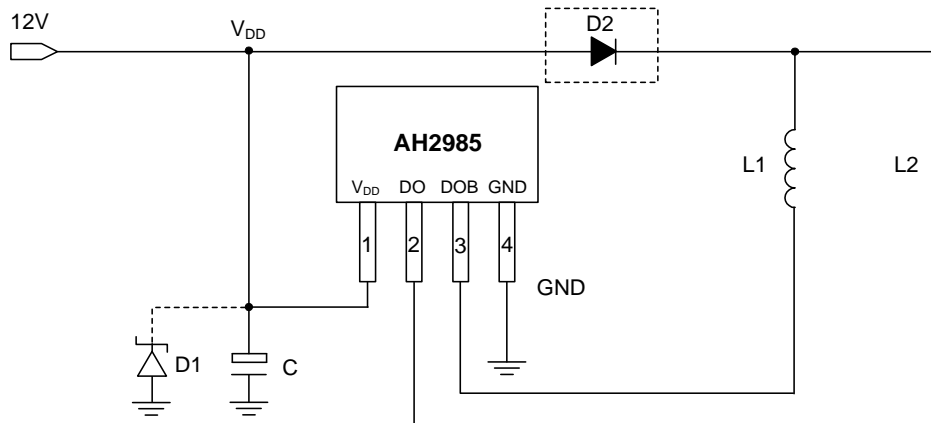

**12V Brushless DC Fan**

Note: 4. D1 (Zener Diode) and Capacitor C are for power stabilization. Recommended value of C is 1µF/ 50V (E-Cap). Diode D2 is optional and helps to protect the device and fan coils from reverse power conditions. The AH2985 also includes an internal reverse blocking diode at VDD pin.

**Pin Descriptions**

Pin Number	Pin Name	Function
1	V <sub>DD</sub>	Input Power
2	DO	Output Pin
3	DOB	Output Pin
4	GND	Ground

**Functional Block Diagram**

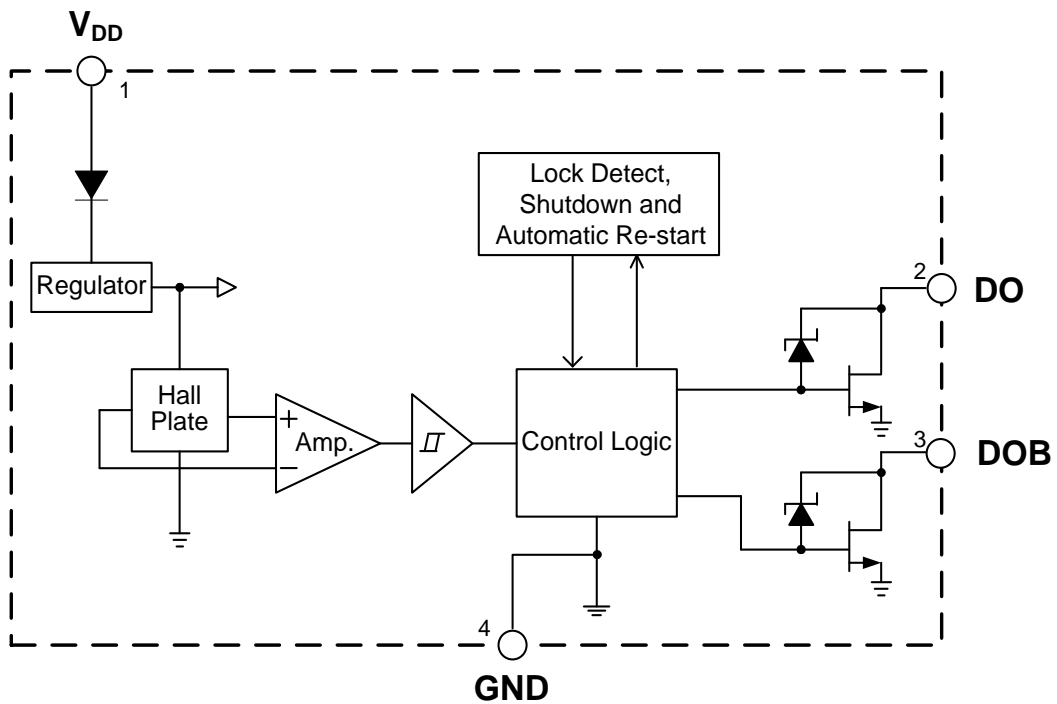

NEW PRODUCT

### Absolute Maximum Ratings (@T<sub>A</sub> = +25°C, unless otherwise specified.) (Note 5)

Symbol	Parameter	Rating	Unit
V <sub>DD</sub>	Supply Voltage	18	V
V <sub>RDD</sub>	Reverse V <sub>DD</sub> Polarity Voltage	-15	V
I <sub>O(AVE)</sub>	Output Current (Note 6)	500	mA
I <sub>O(peak as hold)</sub>		800	
P <sub>D</sub>	Power Dissipation	550	mW
T <sub>STG</sub>	Storage Temperature	-55 to +150	°C
T <sub>J</sub>	Maximum Junction Temperature	+150	°C
θ <sub>JA</sub>	Thermal Resistance	227	°C/W
θ <sub>JC</sub>	Thermal Resistance	49	°C/W

- Notes:
- Stresses greater than those listed under "Absolute Maximum Ratings" may cause permanent damage to the device. These are stress ratings only, and functional operation of the device at these or any other conditions beyond those indicated under "Recommended Operating Conditions" is not implied. Exposure to "Absolute Maximum Ratings" for extended periods may affect device reliability.
  - Shall not exceed P<sub>D</sub> and Safety Operation Area.

### Recommended Operating Conditions (@T<sub>A</sub> = +25°C, unless otherwise specified.)

Symbol	Parameter	Condition	Min	Max	Unit
V <sub>DD</sub>	Supply Voltage	Operating	2.5	15	V
T <sub>A</sub>	Operating Ambient Temperature (Note 6)	Operating	-40	+105	°C

### Electrical Characteristics (@T<sub>A</sub> = +25°C, V<sub>DD</sub> = 12V, unless otherwise specified.)

Symbol	Parameter	Condition	Min	Typ	Max	Unit
I <sub>DD</sub>	Supply Current	Operating, V <sub>DD</sub> = 12V	–	1	5	mA
t <sub>ON</sub>	Locked Protection On Time	–	–	0.45	–	s
t <sub>OFF</sub>	Locked Protection Off Time	–	–	2.7	–	s
R <sub>DUTY</sub>	Locked Protection Duty Ratio	t <sub>OFF</sub> / t <sub>ON</sub>	–	6	–	–
R <sub>DS(ON)</sub>	Output On Resistance	I <sub>O</sub> = 300mA	–	1	1.6	Ω
		I <sub>O</sub> = 500mA	–	1	1.8	
V <sub>Z</sub>	Output Zener-Breakdown Voltage	(Note 7)	20	28	36	V

Note: 7. The V<sub>Z</sub> value is in D.C. voltage measurement. The V<sub>Z</sub> may vary with coils in A.C. voltage measurements.

**Magnetic Characteristics** ( $T_A = +25^\circ\text{C}$ ,  $V_{DD} = 2.5\text{V to }15\text{V}$ , Note 8)

(1mT=10 Gauss)

Symbol	Parameter	Min	Typ	Max	Unit
B <sub>OP</sub>	Operate Point	5	30	60	Gauss
B <sub>RP</sub>	Release Point	-60	-30	-5	Gauss
B <sub>HY</sub>	Hysteresis	20	60	120	Gauss

Note: 8. The magnetic characteristics may vary with supply voltage, operating temperature and after soldering.

**Operating Characteristics**

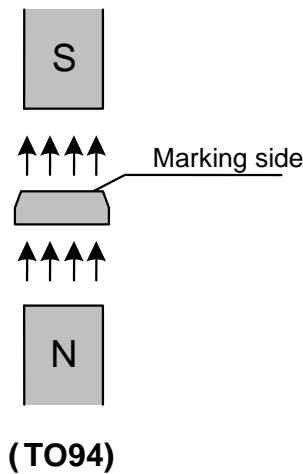
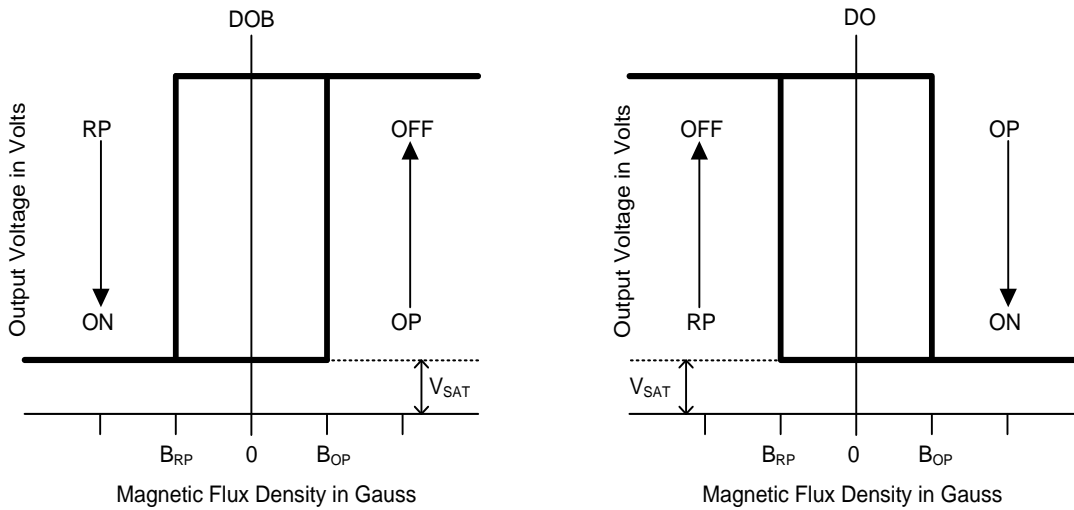

**Performance Characteristics**

(1) TO94

$T_A(^{\circ}\text{C})$	<b>25</b>	<b>50</b>	<b>60</b>	<b>70</b>	<b>80</b>	<b>85</b>	<b>90</b>	<b>95</b>	<b>100</b>
$P_D(\text{mW})$	550	440	396	352	308	286	264	242	220
$T_A(^{\circ}\text{C})$	<b>105</b>	<b>110</b>	<b>115</b>	<b>120</b>	<b>125</b>	<b>130</b>	<b>135</b>	<b>140</b>	<b>150</b>
$P_D(\text{mW})$	198	176	154	132	110	88	66	44	0

$P_D$  (mW)

Power Dissipation Curve

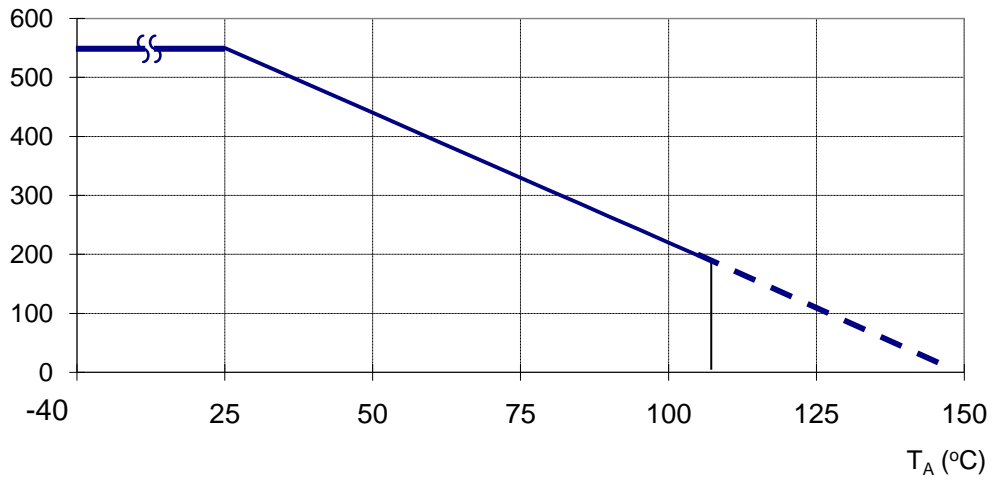

**Ordering Information** (Note 9)

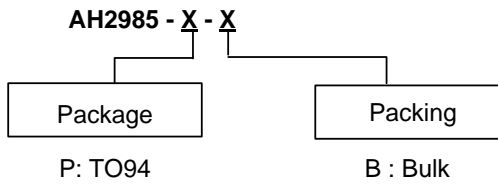

Part Number	Package Code	Packaging (Note 9)	Bulk	
			Quantity	Part Number Suffix
AH2985-P-B	P	TO94	1000	-B

Note: 9. For packaging details, go to our website at <http://www.diodes.com/products/packages.html>.

**Marking Information**

(1) TO94

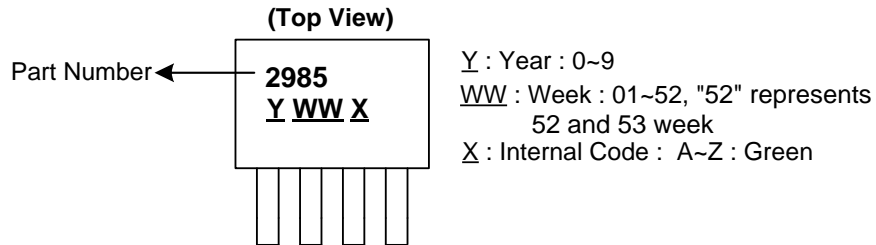

**Package Outline Dimensions** (All dimensions in mm.)

Please see AP02002 at <http://www.diodes.com/datasheets/ap02002.pdf> for the latest version.

(1) Package Type: TO94

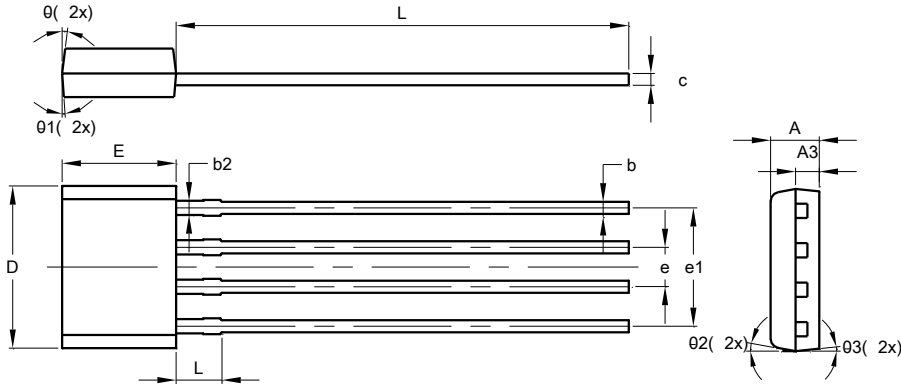

TO94			
Dim	Min	Max	Typ
A	1.46	1.66	1.56
A3	-	-	0.76
b	0.35	0.56	0.39
b2	-	-	0.46
c	0.36	0.51	0.38
D	5.12	5.32	5.22
E	3.55	3.75	3.65
e	-	-	1.27
e1	-	-	3.81
L	13.50	15.50	14.50
L1	-	-	1.42
S	0.63	0.83	0.73
theta	-	-	6°
theta1	-	-	4°
theta2	-	-	11°
theta3	-	-	6°
All Dimensions in mm			

Min/Max(in mm)

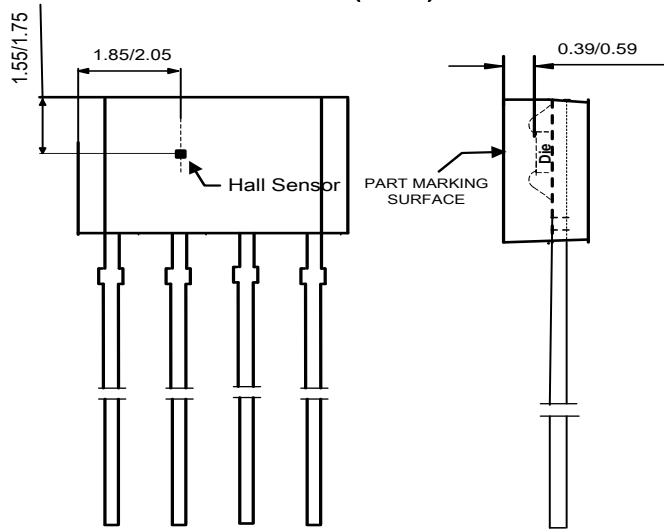

NEW PRODUCT

**IMPORTANT NOTICE**

DIODES INCORPORATED MAKES NO WARRANTY OF ANY KIND, EXPRESS OR IMPLIED, WITH REGARDS TO THIS DOCUMENT, INCLUDING, BUT NOT LIMITED TO, THE IMPLIED WARRANTIES OF MERCHANTABILITY AND FITNESS FOR A PARTICULAR PURPOSE (AND THEIR EQUIVALENTS UNDER THE LAWS OF ANY JURISDICTION).

Diodes Incorporated and its subsidiaries reserve the right to make modifications, enhancements, improvements, corrections or other changes without further notice to this document and any product described herein. Diodes Incorporated does not assume any liability arising out of the application or use of this document or any product described herein; neither does Diodes Incorporated convey any license under its patent or trademark rights, nor the rights of others. Any Customer or user of this document or products described herein in such applications shall assume all risks of such use and will agree to hold Diodes Incorporated and all the companies whose products are represented on Diodes Incorporated website, harmless against all damages.

Diodes Incorporated does not warrant or accept any liability whatsoever in respect of any products purchased through unauthorized sales channel. Should Customers purchase or use Diodes Incorporated products for any unintended or unauthorized application, Customers shall indemnify and hold Diodes Incorporated and its representatives harmless against all claims, damages, expenses, and attorney fees arising out of, directly or indirectly, any claim of personal injury or death associated with such unintended or unauthorized application.

Products described herein may be covered by one or more United States, international or foreign patents pending. Product names and markings noted herein may also be covered by one or more United States, international or foreign trademarks.

This document is written in English but may be translated into multiple languages for reference. Only the English version of this document is the final and determinative format released by Diodes Incorporated.

**LIFE SUPPORT**

Diodes Incorporated products are specifically not authorized for use as critical components in life support devices or systems without the express written approval of the Chief Executive Officer of Diodes Incorporated. As used herein:

A. Life support devices or systems are devices or systems which:

1. are intended to implant into the body, or
2. support or sustain life and whose failure to perform when properly used in accordance with instructions for use provided in the labeling can be reasonably expected to result in significant injury to the user.

B. A critical component is any component in a life support device or system whose failure to perform can be reasonably expected to cause the failure of the life support device or to affect its safety or effectiveness.

Customers represent that they have all necessary expertise in the safety and regulatory ramifications of their life support devices or systems, and acknowledge and agree that they are solely responsible for all legal, regulatory and safety-related requirements concerning their products and any use of Diodes Incorporated products in such safety-critical, life support devices or systems, notwithstanding any devices- or systems-related information or support that may be provided by Diodes Incorporated. Further, Customers must fully indemnify Diodes Incorporated and its representatives against any damages arising out of the use of Diodes Incorporated products in such safety-critical, life support devices or systems.

Copyright © 2015, Diodes Incorporated

[www.diodes.com](http://www.diodes.com)



Компания «Life Electronics» занимается поставками электронных компонентов импортного и отечественного производства от производителей и со складов крупных дистрибьюторов Европы, Америки и Азии.

С конца 2013 года компания активно расширяет линейку поставок компонентов по направлению коаксиальный кабель, кварцевые генераторы и конденсаторы (керамические, пленочные, электролитические), за счёт заключения дистрибьюторских договоров

Мы предлагаем:

- Конкуренспособные цены и скидки постоянным клиентам.
- Специальные условия для постоянных клиентов.
- Подбор аналогов.
- Поставку компонентов в любых объемах, удовлетворяющих вашим потребностям.
- Приемлемые сроки поставки, возможна ускоренная поставка.
- Доставку товара в любую точку России и стран СНГ.
- Комплексную поставку.
- Работу по проектам и поставку образцов.
- Формирование склада под заказчика.
- Сертификаты соответствия на поставляемую продукцию (по желанию клиента).
- Тестирование поставляемой продукции.
- Поставку компонентов, требующих военную и космическую приемку.
- Входной контроль качества.
- Наличие сертификата ISO.

В составе нашей компании организован Конструкторский отдел, призванный помогать разработчикам, и инженерам.

Конструкторский отдел помогает осуществить:

- Регистрацию проекта у производителя компонентов.
- Техническую поддержку проекта.
- Защиту от снятия компонента с производства.
- Оценку стоимости проекта по компонентам.
- Изготовление тестовой платы монтаж и пусконаладочные работы.



Тел: +7 (812) 336 43 04 (многоканальный)

Email: [org@lifeelectronics.ru](mailto:org@lifeelectronics.ru)