

M1G055 Series

Motors

1/50 HP Refrigeration Fan Motor (ESM)

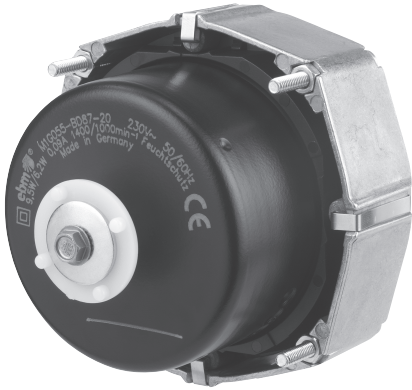

- EC-motor with completely integrated electronics
- AC-line operation
- Proven external rotor motor principle
- Power output up to 14 Watt at 1550 RPM
- Moisture protection suitable for commercial refrigeration
- Ball bearings
- High life expectancy > 40,000 hours

Part Number	CFM @ 0	VAC	Hertz	Power Output (W)	Temp. range (°C)	Speed (RPM)	Wgt. (lbs)
M1G055-BD97-47	338*	115	50/60	14	-30 to 50	1550	1.87

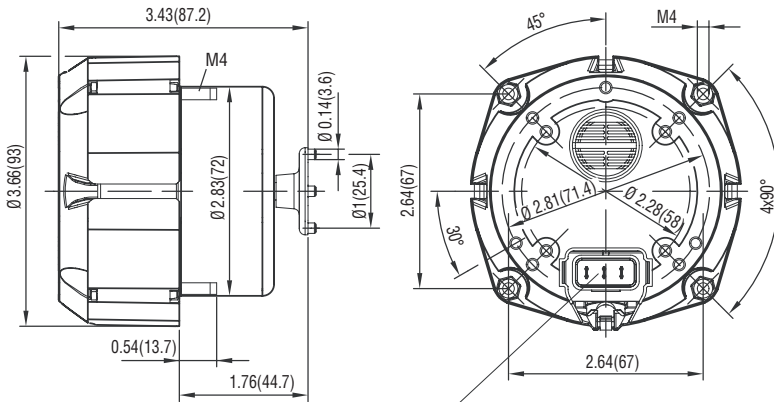

incl. mains cable with plug (450 mm length)

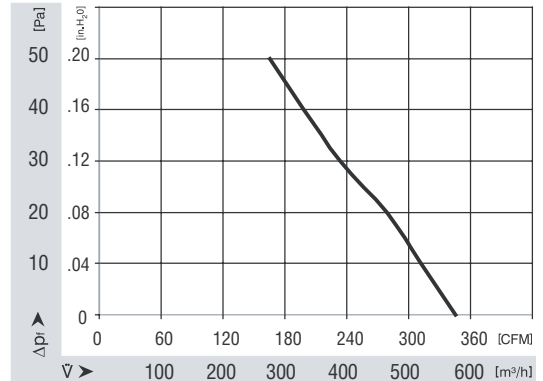
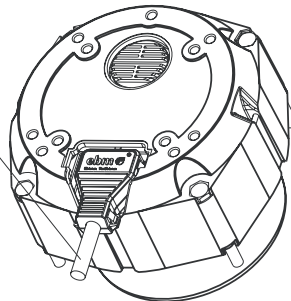

*Note: Measured with 5-bladed sheet metal impeller 9-inch/22°



M1G055 Series cont. Motors

1/50 HP Refrigeration Fan Motor (ESM)

- Substitutes standard motors due to common footprint
- Use with standard sheet metal impellers
- Complete range of accessories:
 - ▶ Flat fan guards
 - ▶ Basket fan guards
 - ▶ Wall-rings with motor mounts

Technical Data

▶ Speed:	1550 RPM
▶ Rated Voltage:	115 VAC
▶ Mains Frequency:	50/60 Hz
▶ Approvals:	CE, VDE EN60335, UL1004-3
▶ Interference Emission:	EN50081-1
▶ Interference Immunity:	EN61000-6-2
▶ Protection Class:	2
▶ Type of Protection:	IP54
▶ Weight:	1.87 lbs (0.85 kg)
▶ Ambient Temperature:	-30° C to 50° C

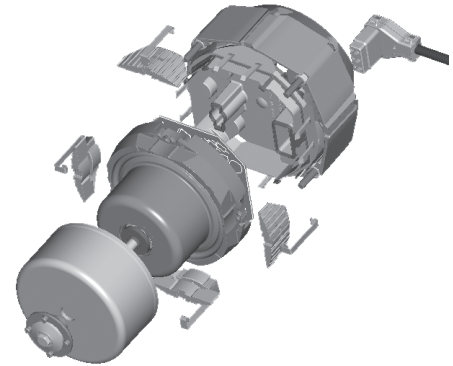

Optimized Efficiency

- ▶ Efficiency > 65 %
- ▶ Only 1/3 of the power input of shaded-pole motors
- ▶ Little heat load
- ▶ Quick pay back

Comparison in efficiency curves of the ESM and standard shaded-pole motor

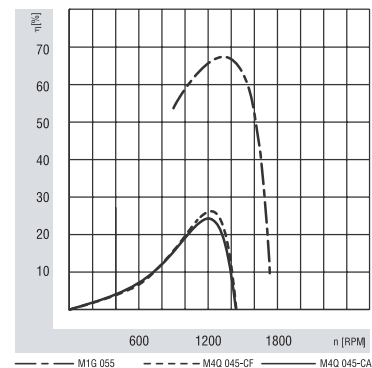

Energy-saving motors (ESM)



- **Material:** Housing made of die-cast aluminium
Rotor: Coated in black
- **Direction of air flow:** "V" or "A" (depending on axial impeller used)
- **Direction of rotation:** Counter-clockwise, seen on shaft end
- **Type of protection :** IP 54
- **Insulation class:** "B"
- **Mounting position:** Any
- **Condensate discharges:** None
- **Mode of operation:** Continuous operation (S1)
- **Bearings:** Maintenance-free ball bearings

Nominal data	Curve	Nominal voltage	Frequency	Upper speed ⁽¹⁾	Lower speed ⁽¹⁾	Power input	Power output	Perm. amb. temp.	Mass
Type		VAC	Hz	rpm	rpm	W	W	°C	kg
M1G055-BD95 -12	Ⓐ	1~ 115	50/60	2200	1500	22.0	15.0	-30 to +50	0.9
M1G055-BD91 -12	Ⓐ	1~ 230							
M1G055-BD95 -16	Ⓑ	1~ 115	50/60	1750	1300	22.0	12.5	-30 to +50	0.9
M1G055-BD91 -16	Ⓑ	1~ 230							
M1G055-BD95 -21	Ⓒ	1~ 115	50/60	1550	1100	21.0	10.4	-30 to +50	0.9
M1G055-BD91 -21	Ⓒ	1~ 230							

subject to alterations

(1) preprogrammed speeds

Including line cord with plug (450 mm long)

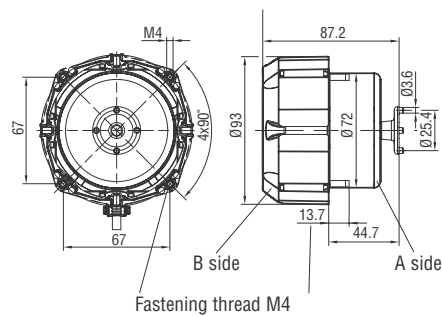
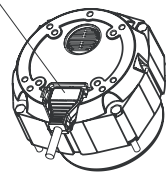

- **Motor protection:** Via electronics
 - **Electrical connection:** Line cord with plug
 - **Protection class:** II
 - **Product conforming to standard:** CE
 - **Approvals:** VDE, UL
- **Speed settings:** The pre-programmed upper speed is reached with the speed relay open; lower speed is reached when the speed relay is closed. Speeds from 10% to 100% of the maximum speed can be preset using the programming unit. However, we recommend not allowing it to fall below 1000 rpm (ⒶⒷⒸ).
 - **Mounting:** Guard grille and wall ring are mounted onto the protruding thread ends of the A side.
 - **Axial impeller mounting:** Mounted to the motor shaft using a plastic adapter with pulling peg and an M4 screw.

- **Electr. connection:**

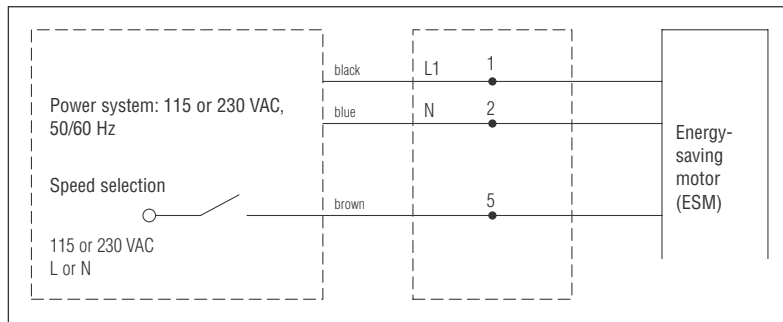

Energy-saving motors (ESM)



- **Material:** Housing made of die-cast aluminium
Rotor: Coated in black
- **Direction of air flow:** "V" or "A" (depending on axial impeller used)
- **Direction of rotation:** Counter-clockwise, seen on shaft end
- **Type of protection:** IP 54
- **Insulation class:** "B"
- **Mounting position:** Any
- **Condensate discharges:** None
- **Mode of operation:** Continuous operation (S1)
- **Bearings:** Maintenance-free ball bearings

Nominal data	Curve	Nominal voltage	Frequency	Upper speed (1)	Lower speed (1)	Power input	Power output	Perm. amb. temp.	Mass
Type		VAC	Hz	rpm	rpm	W	W	°C	kg
M1G055-BD91 -45	D	1~ 115	50/60	1400	1000	9.0	5.9	-30 to +50	0.9
M1G055-BD87 -25	D	1~ 230							
M1G055-BD95 -26	E	1~ 115	50/60	1400	1000	27.0	12.0	-30 to +50	0.9
M1G055-BD91 -26	E	1~ 230							
M1G055-BD91 -17	F	1~ 115	50/60	1200	800	12.0	7.5	-30 to +50	0.9
M1G055-BD87 -17	F	1~ 230							
M1G055-BD95 -30	G	1~ 115	50/60	1200	800	15.4	6.3	-30 to +50	0.9
M1G055-BD91 -30	G	1~ 230							

subject to alterations

(1) preprogrammed speeds

Including line cord with plug
(450 mm long)

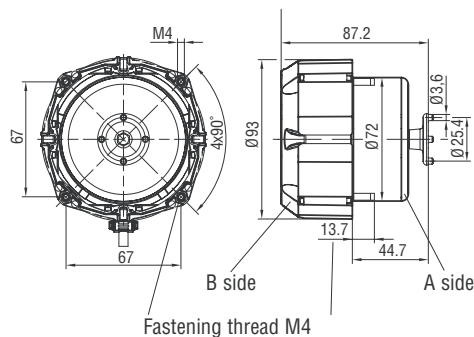
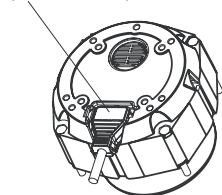

- **Motor protection:** Via electronics
- **Electrical connection:** Line cord with plug
- **Protection class:** II
- **Product conforming to standard:** CE
- **Approvals:** VDE, UL

- **Speed settings:** The pre-programmed upper speed is reached with the speed relay open; lower speed is reached when the speed relay is closed. Speeds from 10% to 100% of the maximum speed can be preset using the programming unit. However, we recommend not allowing it to fall below 600 rpm (E P) or 1000 rpm (E P).
- **Mounting:** Guard grille and wall ring are mounted onto the protruding thread ends of the A side.
- **Axial impeller mounting:** Mounted to the motor shaft using a plastic adapter with pulling peg and an M4 screw.

- **Electr. connection:**

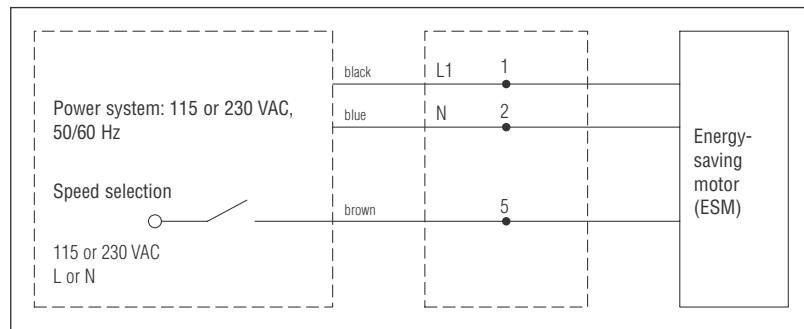

Mounting angles, terminal boxes

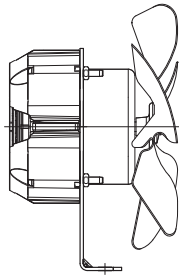
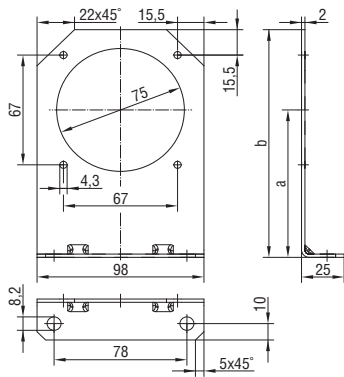

– **Material:** Sheet steel, hot-galvanised

Mounting angle for energy-saving motors (ESM)

Part no.	Size	Max. blade angle α at "V"	Max. blade angle α at "A"	a	b
63500-2-4060	154 / 172	34°	34°	103.0	152.0
63501-2-4060	200	34°	28°	123.0	172.0
63502-2-4060	230 / 254	28°	28°	135.0	184.0

subject to alterations

Компания «Life Electronics» занимается поставками электронных компонентов импортного и отечественного производства от производителей и со складов крупных дистрибьюторов Европы, Америки и Азии.

С конца 2013 года компания активно расширяет линейку поставок компонентов по направлению коаксиальный кабель, кварцевые генераторы и конденсаторы (керамические, пленочные, электролитические), за счёт заключения дистрибьюторских договоров

Мы предлагаем:

- Конкурентоспособные цены и скидки постоянным клиентам.
- Специальные условия для постоянных клиентов.
- Подбор аналогов.
- Поставку компонентов в любых объемах, удовлетворяющих вашим потребностям.
- Приемлемые сроки поставки, возможна ускоренная поставка.
- Доставку товара в любую точку России и стран СНГ.
- Комплексную поставку.
- Работу по проектам и поставку образцов.
- Формирование склада под заказчика.
- Сертификаты соответствия на поставляемую продукцию (по желанию клиента).
- Тестирование поставляемой продукции.
- Поставку компонентов, требующих военную и космическую приемку.
- Входной контроль качества.
- Наличие сертификата ISO.

В составе нашей компании организован Конструкторский отдел, призванный помогать разработчикам, и инженерам.

Конструкторский отдел помогает осуществить:

- Регистрацию проекта у производителя компонентов.
- Техническую поддержку проекта.
- Защиту от снятия компонента с производства.
- Оценку стоимости проекта по компонентам.
- Изготовление тестовой платы монтаж и пусконаладочные работы.



Тел: +7 (812) 336 43 04 (многоканальный)

Email: org@lifeelectronics.ru