

ILB S3 24 DI8 DO4 AO2 INC-IN2

Inline Block IO module for sercos

Data sheet
8345_en_01

© PHOENIX CONTACT 2012-09-13



1 Description

The module is designed for use within a sercos network. It is used for flexible control of two axes of motion regardless of the drive hardware used. Using a ± 10 -V signal, two drive amplifiers and using the incremental signal two rotary transducers can be connected to the module for position acquisition in combination with the digital I/Os for limit and home position switches.

sercos features

- 2 x Ethernet twisted pair according to 802.3u with auto negotiation and auto crossing
- 100 Mbps transmission speed
- I/O areas can be parameterized individually for each channel
- Supports sercos V1.1.2
- sercos diagnostic LED

Features of the digital inputs

- Connections for eight digital sensors
- Connection of sensors in 2 or 3-wire technology
- Maximum permissible load current per sensor: 250 mA
- Maximum permissible load current from the sensor supply: 1 A (0.5 A per group)
- Diagnostic and status indicators

Features of the digital outputs

- Connections for four digital actuators
- Connection of actuators in 2 or 3-wire technology
- Nominal current of each output: 0.5 A
- Total current of all outputs: 4 A
- Short-circuit-proof and overload-protected outputs



Make sure you always use the latest documentation. It can be downloaded at www.phoenixcontact.net/catalog. Here you will also find the current SDDML file.



This data sheet is only valid in association with the UM EN SERCOS SYS sercos system manual for I/O devices and the "Assembly and removal of Inline Block IO modules" application note.

Features of the analog outputs

- Two analog signal outputs for the connection of voltage signals
- Connection of actuators in 2-wire technology
- Voltage range: ± 10 V
- Resolution: 12 bits
- Short-circuit-proof outputs
- Parameterizable output values when the bus fails

**Incremental encoder features
(for linear and rotary encoders)**

Symmetrical incremental encoders (encoder with symmetrical data lines according to the RS 422 EIA standard):

- Encoder supply: 5 V DC or 24 V DC
- Connection method of the signals:
 - A and /A (inverted)
 - B and /B (inverted)
 - Z and /Z (inverted)
- Input frequency < 300 kHz
- Cable length up to 30 m

Asymmetrical incremental encoder (encoder with asymmetrical data cables, push pull 5 V to 24 V):

- Encoder supply: 5 V DC or 24 V DC
- Connection method of signals: A, B, Z
- Input frequency < 300 kHz
- Cable length up to 30 m

2 Table of contents

1 Description..... 1

2 Table of contents 3

3 Ordering data..... 4

4 Technical data 5

5 Internal basic circuit diagram10

6 Electrical isolation11

7 Local diagnostic and status indicators12

8 Connecting sercos, supply, analog sensors, and actuators..... 13

 8.1 sercos connection 13

 8.2 Connecting the supply, actuators, and sensors..... 14

9 Connection notes.....16

10 sercos device profile 16

11 sercos..... 16

 11.1 sercos profiles classes, and function groups 16

 11.2 Electronic rating plate..... 17

12 Startup..... 17

13 IDN list, subdevice 118

14 IDN list, subdevice 225

15 Parameter descriptions31

3 Ordering data

Product

Description	Type	Order No.	Pcs. / Pkt.
Inline Block IO module for sercos for the flexible control of two axes of motion	ILB S3 24 DI8 DO4 AO2 INC-IN2	2700174	1

Accessories: Ethernet

Description	Type	Order No.	Pcs. / Pkt.
Gray RJ45 plug set for linear cable	FL PLUG RJ45 GR/2	2744856	2
Green RJ45 plug set for crossed cable	FL PLUG RJ45 GN/2	2744571	2
Double sheathed Ethernet cable	FL CAT5 HEAVY	2744814	1
Flexible Ethernet cable	FL CAT5 FLEX	2744830	1
Assembly tool for RJ45 plugs	FL CRIMPTOOL	2744869	1



Matching dust protection covers and safety systems for RJ45 connections can be found in the product range from Reichle & DeMassari/Switzerland.

Accessories: Other

Description	Type	Order No.	Pcs. / Pkt.
End clamp for securing the module on the DIN rail for a horizontal mounting position; to the right and left of the module	CLIPFIX 35	3022218	50
End clamp for securing the module on the DIN rail for a vertical mounting position; above and below the module	E/AL-NS 35	1201662	10

Documentation

Description	Type	Order No.	Pcs. / Pkt.
User manual: sercos system manual for I/O devices	UM EN SERCOS SYS	-	-
"Assembly and removal of Inline Block IO modules" application note	AH ILB INSTALLATION	9014931	-

4 Technical data

Housing dimensions

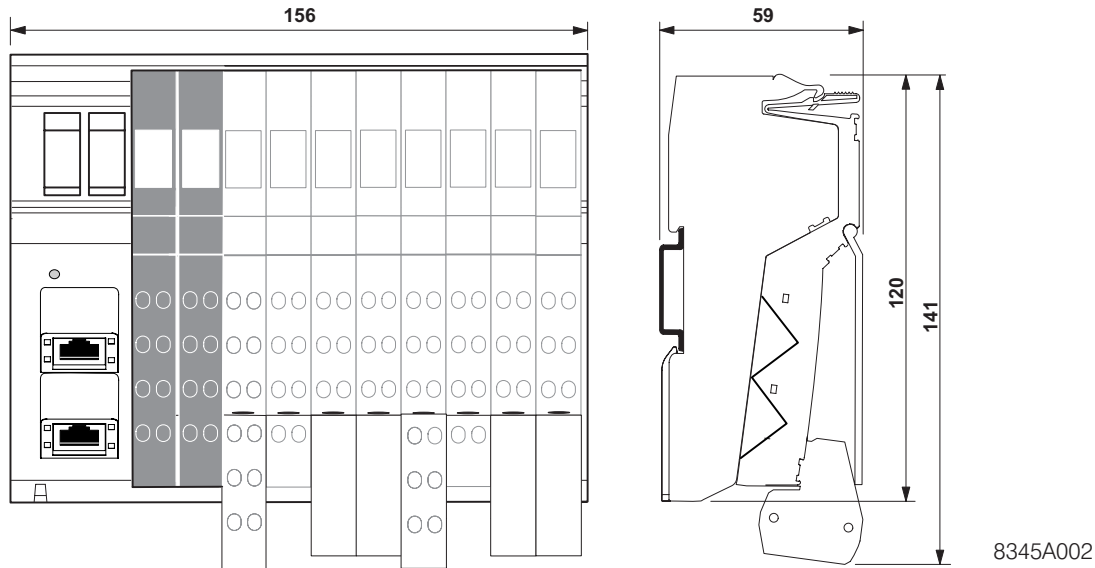

Figure 1 Housing dimensions of the module (in mm)

General data

Weight	505 g (with connectors)
Operating mode	sercos process data mode
Transmission speed	100 Mbps
Connection method for sensors	2- and 3-wire technology (shielded)
Connection method for actuators	2-wire technology (shielded)
Connection data for Inline connectors	
Connection method	Spring-cage terminals
Conductor cross section	0.08 mm ² ... 1.5 mm ² (solid or stranded), 28 - 16 AWG

Ambient conditions

Regulations	Developed according to VDE 0160 / EN 50178 / IEC 62103, UL 508
Ambient temperature (operation)	-25°C ... +60°C
Ambient temperature (storage/transport)	-25°C ... +85°C
Humidity (operation/storage/transport)	10% ... 95%, EN 61131-2
Air pressure (operation/storage/transport)	70 kPa ... 106 kPa (up to 3000 m above sea level)
Degree of protection	IP20
Class of protection	III, IEC 61140, EN 61140, VDE 0140-1
Air and creepage distances	According to DIN VDE 0110/IEC 60664, IEC 60664A, DIN VDE 0160/EN 50178/IEC 62103
Housing material	Plastic, PVC-free, PBT, self-extinguishing (V0)
Pollution degree according to EN 60664-1/IEC 60664-1, EN 61131-2/IEC 61131-2	2; condensation not permitted during operation
Surge voltage class	II

Interface

sercos interface	2 x sercos via RJ45 connector; Shielding via parallel connection of R, C, and VDR
------------------	--

24 V module supply (communications power and sensor supply; U_L and U_S)

Nominal value	24 V DC
Tolerance	-15%/+20% according to DIN EN 61131-2
Ripple	±5% according to DIN EN 61131-2
Permissible range	19.2 V DC to 30.0 V DC
Current consumption at U_L	See "Supply of the module electronics with U_L "
Current consumption at U_S	See "Supply of the sensors with U_S at the digital inputs"
Current consumption from U_{A1}/U_{A2}	See "Supply of the digital outputs with U_{A1}/U_{A2} "
Protective measures for U_L and U_{S1}/U_{S2}	Transient surge protection via arresters, serial protection against polarity reversal
Protective measures for U_{A1}/U_{A2}	Transient surge protection via arresters, serial protection against polarity reversal, channel-specific short-circuit protection
Connection	Via power connectors

Supply of the module logics with U_L

	Typical	Maximum
Current consumption at U_L	750 mA	950 mA
With AO nominal load ($I_{OUT} = 20$ mA with $R_L = 0$ Ω) and connected incremental encoder signals (with supply of the increment encoder, 2 x 250 mA)		

Supply of the sensors with U_S at the digital inputs

	Typical	Maximum
Current consumption at U_{S1}/U_{S2}	-	1 A (0.5 A per group)

Supply of the digital outputs with U_{A1}/U_{A2}

Nominal value U_{A1}/U_{A2}	24 V DC
Current consumption at U_{A1}/U_{A2}	2 A
Protection	Internal, channel-specific electronic fuse, short-circuit-proof

Digital inputs

Number	8
Connection method for sensors	2 and 3-wire technology
Input design	According to EN 61131-2 type 1
Definition of the switching thresholds	
Maximum low-level voltage	$U_{Lmax} < 5$ V
Minimum high-level voltage	$U_{Hmin} > 15$ V
Common potentials	Sensor supply U_S , ground
Nominal input voltage U_{IN}	24 V DC
Permissible range	-30 V < U_{IN} < +30 V DC
Nominal input current at U_{IN}	5 mA, typical
Current flow	Linear in the range 1 V < U_{IN} < 30 V
Delay time	
t_{ON}	Approximately 50 μ s typical, 100 μ s maximum
t_{OFF}	Approximately 145 μ s typical, 400 μ s maximum
Permissible cable length to sensor	100 m
Use of AC sensors	AC sensors in the voltage range < U_{IN} are limited in application
Error message to the higher-level control system	Missing sensor supply Short circuit/overload of sensor supply

Digital outputs

Number	4
Connection method for actuators	2 or 3-wire technology
Nominal output voltage U_{OUT}	24 V DC
Nominal current I_{nom} per channel	0.5 A

Digital outputs [...]

Total current	2 A
Protective measures	Channel-by-channel, electronic protection against short-circuit and overload
Delay time	
t_{ON}	Approximately 40 μ s typical, 200 μ s maximum
t_{OFF}	Approximately 150 μ s typical, 400 μ s maximum
Nominal load	
Ohmic	48 Ω /12 W
Lamp	12 W
Inductive	12 VA (1.2 H, 50 Ω)
Switching frequency with nominal inductive load	0.5 Hz, maximum (1.2 H, 50 Ω)
Overload response	Auto restart
Response with inductive overload	Output may be damaged
Reverse voltage protection against short pulses	Protected against reverse voltages
Resistance to permanently applied reverse voltages	Protected against reverse voltages, permissible current 2 A, maximum
Response upon power down	The output follows the supply voltage without delay.
Limitation of the voltage induced on circuit interruption	-41.0 V
Single maximum energy in freewheeling	1 J, maximum
Protective circuit type	Integrated freewheeling circuit in the output chip
Overcurrent shutdown	At 0.7 A, minimum
Maximum output current when switched off	10 μ A



When not loaded, a voltage can be measured even at an output that is not set.

Error message sent to the higher-level control system	Short circuit/overload of outputs
---	-----------------------------------

Analog outputs

Number	2
Voltage output range	± 10 V
Maximum current per output (per channel)	5 mA
Protective measure	IB IL
Conversion time	75 μ s
Resolution	12 bits (0.005 V/LSB)
Output load	
Voltage output	$R_{Lmin} = 2$ k Ω
Transient protection	Yes, internally via arresters
Connection method of signals	2-wire termination; shielded, twisted pair cable
Short circuit protection	
Voltage output	Yes, permanent electronic short-circuit protection
Enabling function	Yes, internal electronic
Optical indicators	5% output LED, channel-specific

Permissible cable lengths

Permissible cable lengths	30 m
---------------------------	------



The ambient conditions and the local conditions in the system can result in special requirements for the installation of cables. These must be taken into consideration accordingly.
For the integration of shielded I/O cables in an equipotential bonding concept for the automation system, the following applies in principle: Shielded analog I/O cables may only be connected directly to functional earth ground potential at a single point. This results in the prevention of voltage equalization currents via the analog cable. Additional information is available on request.

Tolerances at $T_A = 25^\circ\text{C}$

AO output range	Absolute (typical)	Absolute (maximum)	Relative (typical)	Relative (maximum)
±10V	±10 mV	±15 mV	0.1%	±0.2%



The data contains the offset error, gain error, and linearity error. All percentage values refer to the relevant measuring range final value. Unless stated otherwise, the values refer to nominal operation (nominal voltage $U_S = U_L = 24\text{ V}$, preferred horizontal mounting position, "IB IL" format).
The maximum tolerance values represent the worst case measurement inaccuracy. They contain the theoretically maximum possible tolerances in the corresponding measuring ranges. In the same way, the theoretical maximum possible tolerances of the calibration and test equipment have been taken into account.

Incremental encoder inputs

Number	2
Encoder signal	Two pulse trains (A and B, electrically shifted by 90° , leading or lagging depending on the direction of rotation) and one zero pulse (Z)



The corresponding red Ex LED (x = 1 to 4) lights up when the encoder cable is broken.

Connection method of signals	Shielded cable
------------------------------	----------------



Unshielded cables may lead to erroneous results in environments subject to heavy noise.

Encoder types

Symmetrical incremental encoders

Signal	5 V DC (symmetrical pulse train (RS-422) with transversal track)
Encoder supply	5 V DC or 24 V DC
Connection method of signals	A and /A, B and /B, Z and /Z
Signal voltage level	Differential signal (signal – inverted signal) ±0.5 V, minimum; ±6.0 V, maximum
Common mode range: signal–ground	-10 V ... +13.2 V
Input frequency	Up to 300 kHz
Cable length (for shielded cable)	< 30 m (to ensure conformance with EMC Directive)

Asymmetrical incremental encoders

Signal	5 V DC ... 24 V DC (asymmetrical pulse train without transversal track)
Encoder supply	5 V DC or 24 V DC
Connection method of signals	A, B, Z
Signal voltage level	Low ≤ 2.5 V, high ≥ 3.5 V (27 V, maximum)
Input frequency	Up to 300 kHz
Cable length (for shielded cable)	< 30 m (to ensure conformance with EMC Directive)

Electrical isolation/isolation of the voltage areas

Test distance	Test voltage
sercos/logic area	500 V AC, 50 Hz, 1 min
sercos/analog I/O	500 V AC, 50 Hz, 1 min
sercos/communications power U_L	500 V AC, 50 Hz, 1 min
sercos/initiator supply U_S	500 V AC, 50 Hz, 1 min
sercos/functional earth ground	500 V AC, 50 Hz, 1 min
Incremental inputs/ I/O	500 V AC, 50 Hz, 1 min
Incremental inputs/functional earth ground	500 V AC, 50 Hz, 1 min
Incremental inputs/functional earth ground	500 V AC, 50 Hz, 1 min
Logic area/analog I/O	500 V AC, 50 Hz, 1 min
Logic area/communications power U_L	500 V AC, 50 Hz, 1 min
Logic area/initiator supply U_S	500 V AC, 50 Hz, 1 min
Logic area/functional earth ground	500 V AC, 50 Hz, 1 min
Analog I/O/communications power U_L	500 V AC, 50 Hz, 1 min
Analog I/O/initiator supply U_S	500 V AC, 50 Hz, 1 min
Analog I/O/functional earth ground	500 V AC, 50 Hz, 1 min
Communications power U_L /initiator supply U_S	500 V AC, 50 Hz, 1 min
Communications power U_L /functional earth ground	500 V AC, 50 Hz, 1 min
Initiator supply U_S /functional earth ground	500 V AC, 50 Hz, 1 min

Mechanical requirements

Vibration test sinusoidal vibrations according to IEC 60068-2-6/EN 60068-2-6	5g load, 2.5 hours in each space direction
Shock test according to EN 60068-2-27/IEC 60068-2-27	30g load for 11 ms, half sinusoidal wave, three shocks in each space direction and orientation
Broadband noise according to EN 60068-2-64/IEC 60068-2-64	0.78g load, 2.5 hours in each space direction

Conformance with EMC directive 2004/108/EC

Noise immunity test according to EN 61000-6-2

Electrostatic discharge (ESD)	EN 61000-4-2 IEC 61000-4-2	Criterion B 4 kV contact discharge 8 kV air discharge
Electromagnetic fields	EN 61000-4-3 IEC 61000-4-3	Criterion A Field strength: 10 V/m
Fast transients (burst)	EN 61000-4-4 IEC 61000-4-4	Criterion B Remote bus: 2 kV Voltage supply: 2 kV I/O cables: 2 kV Criterion A All interfaces: 1 kV
Surge voltage	EN 61000-4-5 IEC 61000-4-5	Criterion B DC supply lines: ± 0.5 kV/ ± 0.5 kV (symmetrical/asymmetrical) Signal lines: ± 1 kV/ ± 1 kV (symmetrical/asymmetrical)
Conducted interferences	EN 61000-4-6 IEC 61000-4-6	Criterion A Test voltage 10 V

Noise emission test according to EN 61000-6-4

Radiated noise emission	EN 55011	Class A
-------------------------	----------	---------

Approvals

For the latest approvals, please visit www.phoenixcontact.net/catalog.

5 Internal basic circuit diagram

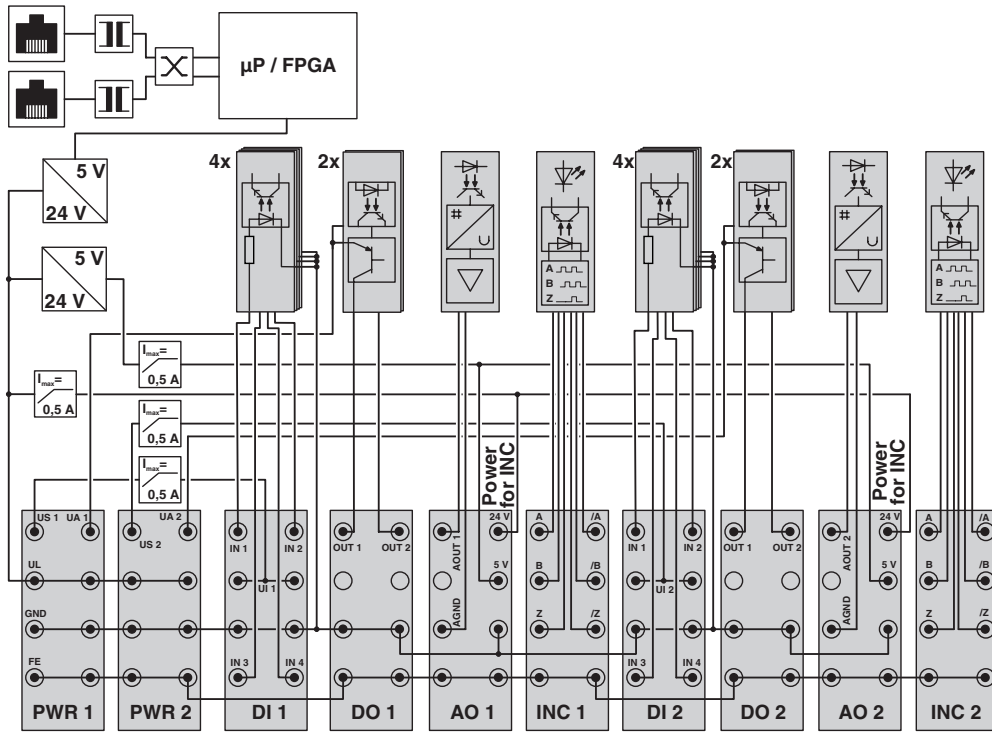
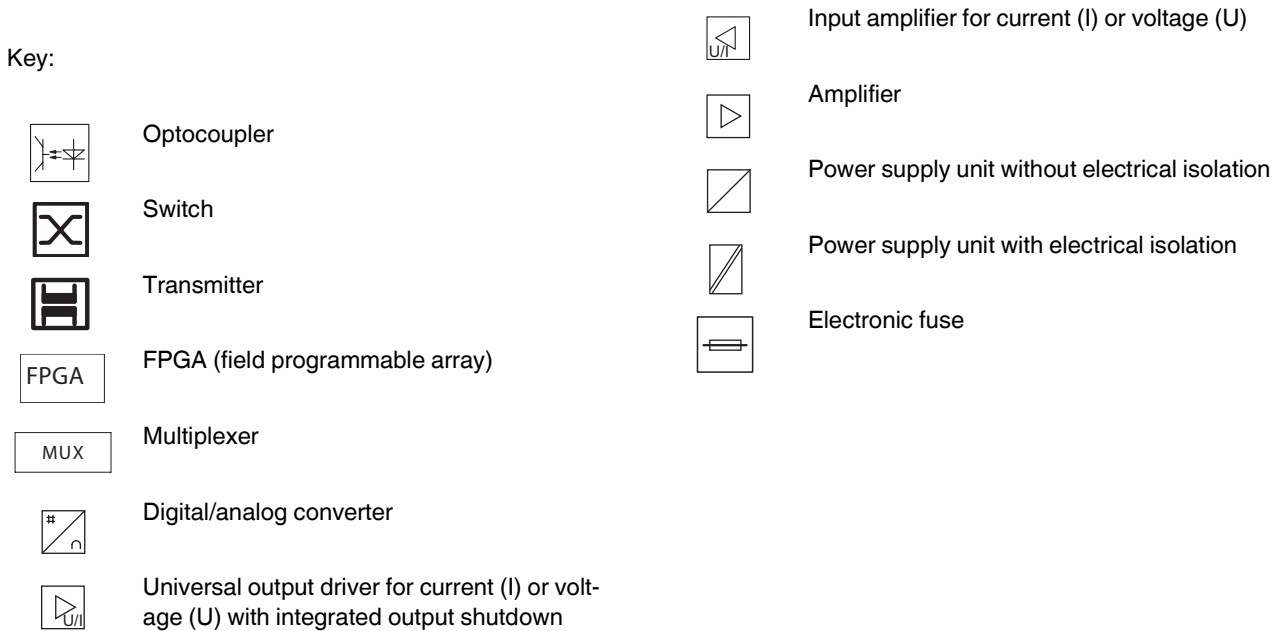

Figure 2 Internal wiring of the terminal points



6 Electrical isolation

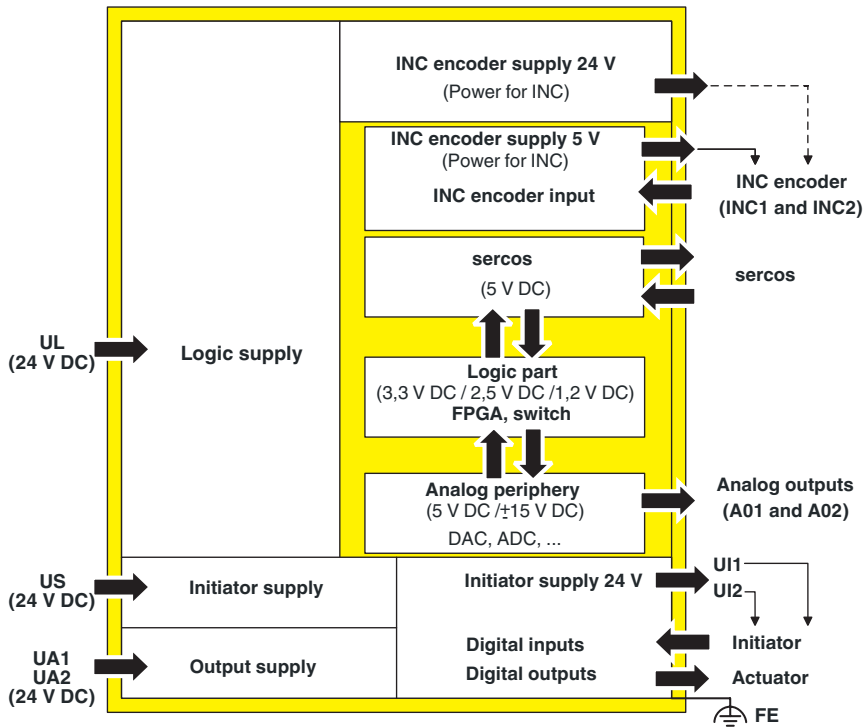

Figure 3 Electrical isolation of the individual function areas



Shield

The shielding ground of the connected twisted pair cables is electrically connected to FE. When connecting network segments, avoid ground loops, potential transfers, and voltage equalization currents via the braided shield.



NOTE: Electrostatic discharge

The module contains components that can be damaged or destroyed by electrostatic discharge. When handling the module, observe the necessary safety precautions against electrostatic discharge (ESD) according to EN 61340-5-1 and IEC 61340-5-1.



Housing

Only personnel authorized by Phoenix Contact are permitted to open the housing.

7 Local diagnostic and status indicators

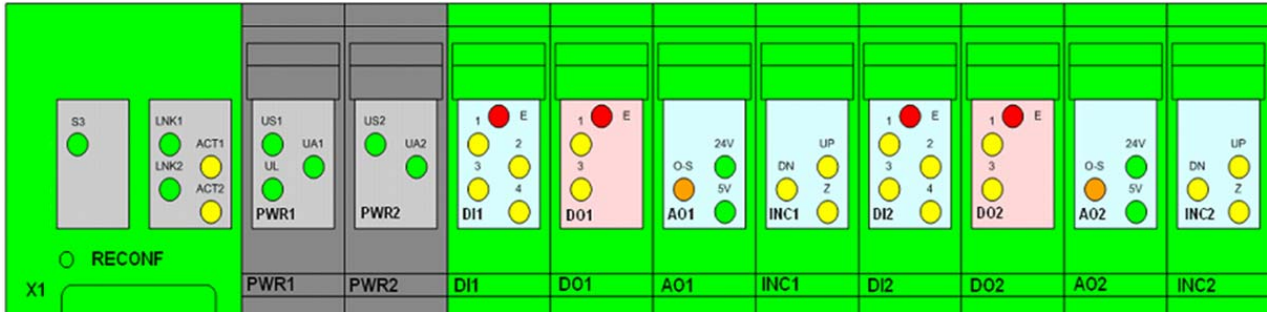

Figure 4 Local diagnostic and status indicators

LED	Color/status	Meaning
sercos		
S3	Green	
	ON:	CP4 no error
	Flashing at 4 Hz:	Loop back activated
	Red	
	ON:	SIII C1D (Class 1 diagnostics)
	Flashing at 4 Hz:	Error on the module
	Red/green	
	Flashing at 4 Hz:	WARNING: Loss of sercos telegram
	Orange	
	ON:	CP0 ... CP3
	Flashing at 4 Hz:	Identification (bit 15 in device control) Used for address assignment and configuration errors
	OFF:	24 V communications power not present or no sercos communication
LNK1/2	Green	Link1/2
	ON:	The connection to a module via Ethernet is established using port 1/2
ACT1/2	Yellow	Activity1/2
	ON:	If the yellow LED is on, this indicates transmission or reception of a telegram at port 1/2.

LED	Color/status	Meaning
PWR1/PWR2		
US1/2	Green	Sensor supply 1/2
	ON:	Sensor supply 1/2 present
	OFF:	Sensor supply 1/2 not present
UA1/2	Green	Actuator supply 1/2
	ON:	Actuator supply 1/2 present
	OFF:	Actuator supply 1/2 not present
UL	Green	24 V communications power
	ON:	24 V communications power present
	OFF:	24 V communications power not present
DI1 ... DI4		
E	Red	Sensor supply error
	ON:	Short-circuit or overload of one of the sensor supplies
	OFF:	No sensor supply error
1 ... 4	Yellow	Status indicators for the inputs
	ON:	Input active
	OFF:	Input not active
DO1/DO2		
E	Red	Output error message
	ON:	Output short circuit or overload
	OFF:	No output error
1/2	Yellow	Output status indicators
	ON:	Output active
	OFF:	Output not active.

LED	Color/status	Meaning
AO1/AO2		
24 V	Green	Status of the 24 V sensor supply
	ON:	24 V sensor supply present
	OFF:	24 V sensor supply not present
O-S	Orange	Behavior of the analog output in the event of an interruption
	ON:	Behavior of the analog output when the connection to the sercos master is interrupted: The default upon delivery is parameterized.
5 V	Green	Status of the 5 V sensor supply
	ON:	5 V sensor supply present
	OFF:	5 V sensor supply not present.
INC1/INC2		
UP	Yellow	State of position counter
	ON and DN LED OFF:	Position counter counting upwards
	OFF and DN LED OFF:	Stopped
DN	Yellow	State of position counter
	ON and UP LED OFF:	Position counter counting upwards
	OFF and UP LED OFF:	Stopped
Z	Yellow	State of position counter
	ON:	Z signal present
	OFF:	Z signal not active

8 Connecting sercos, supply, analog sensors, and actuators

8.1 sercos connection

By default upon delivery, the Ethernet connections have been set to auto negotiation with auto crossing.

The module can be connected with a 1:1 cable or a cross-over cable.

Connect sercos to the module via an 8-pos. RJ45 connector. For the pin assignment of the female connector, please refer to the following table:

Pin	Assignment
1	TD+ (transmit data +)
2	TD- (transmit data -)
3	RD+ (receive data +)
4	Reserved
5	Reserved
6	RD- (receive data -)
7	Reserved
8	Reserved

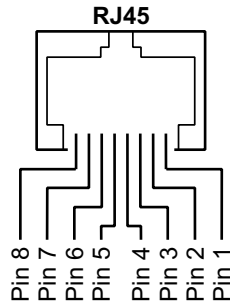

Figure 5 Pin assignment of RJ45 sockets

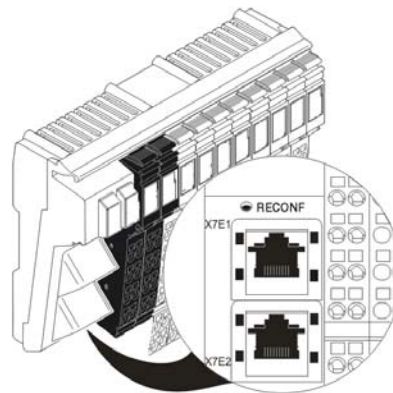

Figure 6 8-pos. RJ45 sockets

Shield
 The shielding ground of the connected twisted pair cables is electrically connected to the socket. When connecting network segments, avoid ground loops, potential transfers, and voltage equalization currents via the braided shield.

Observe bending radii
 The housing dimensions specified under “General data” on page 5 refer to the bus coupler with Inline connectors without Ethernet connection. When installing the bus coupler in a control box observe the bending radii of the Ethernet cables and the connectors used. If required, use angled RJ45 connectors to maintain these bending radii.

8.2 Connecting the supply, actuators, and sensors

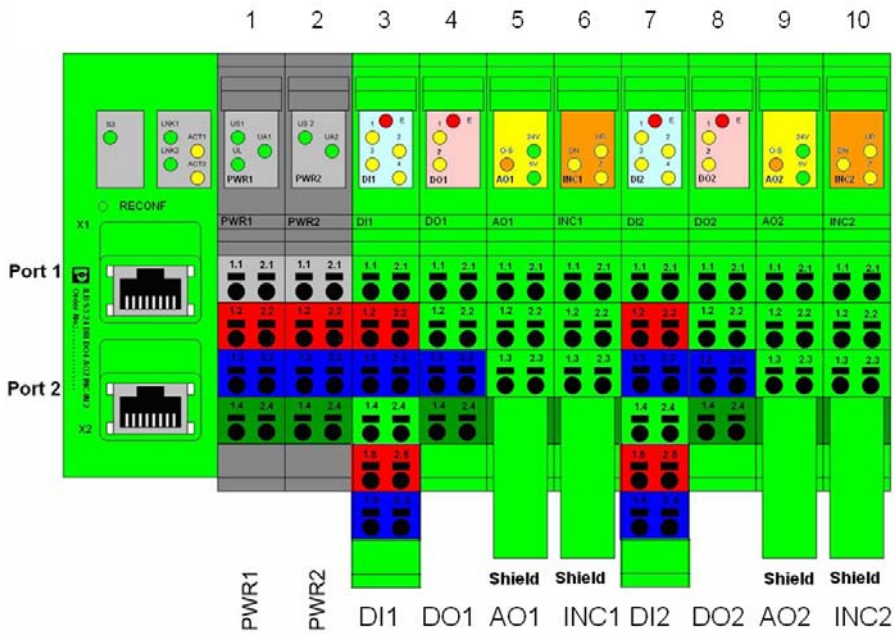

Figure 7 Terminal point assignment of the connectors

Power is supplied via the PWR1 and PWR2 terminals. Sensors and actuators of axis1 or I/O group1 are supplied via PWR1, and those of axis2 or I/O group2 are supplied via PWR2.

Inline power connector 1 (PWR1)			
Terminal point	Assignment	Terminal point	Assignment
1.1	24 V sensor supply U_{S1}	2.1	Actuator supply U_{A1}
1.2	24 V communications power U_L	2.2	24 V communications power U_L
1.3	GND	2.3	GND
1.4	FE	2.4	FE

Inline power connector 2 (PWR2)			
Terminal point	Assignment	Terminal point	Assignment
1.1	24 V sensor supply U_{S2}	2.1	Actuator supply U_{A2}
1.2	24 V communications power U_L	2.2	24 V communications power U_L
1.3	GND	2.3	GND
1.4	FE	2.4	FE

Inline connector 3 and Inline connector 7 (DI1 and DI2)			
Terminal point	Assignment	Terminal point	Assignment
1.1	Signal input 1 (IN 1)	2.1	Signal input 2 (IN 2)
1.2	Sensor voltage U_{S1}/U_{S2} for 2 and 3-wire termination	2.2	Sensor voltage U_{S1}/U_{S2} for 2 and 3-wire termination
1.3	Ground contact (GND) for 3-wire termination	2.3	Ground contact (GND) for 3-wire termination
1.4	Signal input 3 (IN 3)	2.4	Signal input 4 (IN 4)
1.5	Sensor voltage U_{S1}/U_{S2} for 2 and 3-wire termination	2.5	Sensor voltage U_{S1}/U_{S2} for 2 and 3-wire termination
1.6	Ground contact (GND) for 3-wire termination	2.6	Ground contact (GND) for 3-wire termination

Inline connector 4 and Inline connector 8 (DO1 and DO2)			
Terminal point	Assignment	Terminal point	Assignment
1.1	Signal output 1 (OUT1)	2.1	Signal output 2 (OUT2)
1.2	Not used	2.2	Not used
1.3	Ground contact (GND) for 3-wire termination	2.3	Ground contact (GND) for 3-wire termination
1.4	FE	2.4	FE

Inline connector 5 and Inline connector 9 (AO1 and AO2)			
Terminal point	Assignment	Terminal point	Assignment
1.1	Analog output (AOUT1)	2.1	24 V encoder supply
1.2	Not used	2.2	5 V encoder supply
1.3	AGND	2.3	GND
1.4	FE	2.4	FE

Inline connector 6 and Inline connector 10 (INC1 and INC2)			
Terminal point	Assignment	Terminal point	Assignment
1.1	A+	2.1	A-
1.2	B+	2.2	B-
1.3	Z+	2.3	Z-
1.4	FE	2.4	FE

9 Connection notes



The module has an FE spring (metal clip) on the bottom of the electronics base. This spring establishes an electrical connection to the DIN rail. Use grounding terminals to connect the DIN rail to protective earth ground. The module is grounded when it is snapped onto the DIN rail.

To ensure reliable functional earth grounding of the module even when the DIN rail is dirty or the metal clip is damaged, always ground the module additionally via the FE terminal point.



Always connect the analog sensors using shielded, twisted pair cables. Connect the shielding to the module using the shield connection clamp. The clamp connects the shield to FE on the module side. Avoid connection to FE from both sides.



The module is supplied with a shield connector and a standard connector for each input channel. The shield connection can be used for the standard signal (current/voltage).

10 sercos device profile

The device consists of two subdevices. Each subdevice has an I/O resource (FSP-IO) and a drive resource (FSP-Drive).

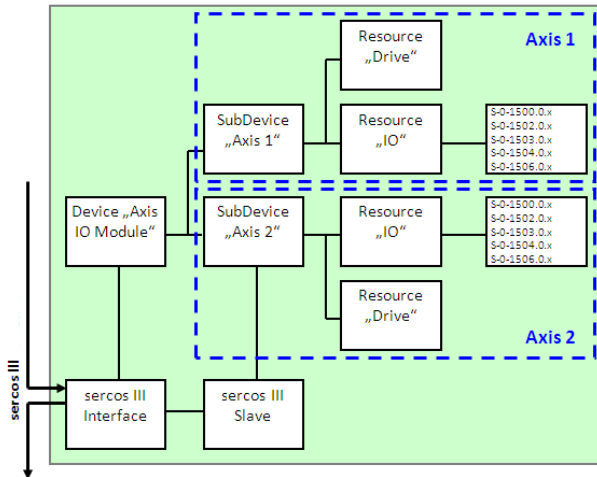

Figure 8 Device profile

11 sercos

Up to a sercos cycle time of 500 μ s, all inputs and outputs are detected or output clock-synchronously to the sercos cycle.

With sercos cycle times of less than 500 μ s, the I/O update cycle time is 500 μ s.

The module allows a maximum of two real-time connections (IDN/S-0-1050.0.x and IDN/S-0-1050.3.x).

11.1 sercos profiles classes, and function groups

The following sercos profiles and classes according to the specification version V1.1.2 are implemented in the module:

sercos device profile: (GDP: Generic Device Profile)

Basic device profile (GDP_Basic)

- Diagnostics (FG_Diagnosis)
- Administration (FG_Administration)
- Device identification (FG_Identification)

sercos communication profile (SCP: Communication Profiles)

- Variable configuration (SCP_VarCfg)
- Synchronisation (SCP_Sync)
- Watchdog (SCP_WD)
- Diagnostics (SCP_Diag)
- Unified Communication Channel (SCP_NRT)
- GDP basic profile (GDP_Basic)
- Electronic rating plate (FG Identification)

sercos function profile (FSP: Function-Specific Profile IO)

- I/O profile (FSP_IO)
- Drive profile (FSP-Drive)

11.2 Electronic rating plate

The electronic rating plate includes the following IDNs.

IDN		Contents
S-0-1300.0.01	Component Name	PxC axis IO module
S-0-1300.0.02	VendorName	„Phoenix Contact“
S-0-1300.0.03	VendorCode	„200“
S-0-1300.0.04	DeviceName	„ILB S3 24 DI8 DO4 AO2 INC-IN2“
S-0-1300.0.05	VendorDevice ID	„2700174“
S-0-1300.0.06	Connected to sub-deviceModul	0
S-0-1300.0.07	Function Revision	1
S-0-1300.0.08	Hardware Revision	V01R02
S-0-1300.0.09	SoftwareRevision	V01R27.Nf
S-0-1300.0.10	Firmware loader Revision	V01R01
S-0-1300.0.11	Order number	„2700174“
S-0-1300.0.12	Serial number	“171949-xxxxx”, xxxxx = consecutive number, starting with 00001
S-0-1300.0.13	Manufacturing date	z.B. „2009-06-15T12:00:30Z“
S-0-1300.0.14	QS date	Date of final test after production
S-0-1300.0.20	Operational hours	Operating hours counters
S-0-1300.0.21	Service date	Service date (e.g. firmware update)
S-0-1300.0.22	Calibration date	Calibration date
S-0-1300.0.23	Calibration due date	Date of next calibration
S-0-1300.0.128		FPGA version identification
S-0-1300.0.129		Identification of the processor kernel
S-0-1300.0.130		Time stamp of FPGA creation
S-0-1300.0.131		Identification of the configuration data record stored in the flash
S-0-1300.0.132		Checksum of the firmware
S-0-1300.0.133		Last boot filename assigned via BootP
S-0-1300.0.134		Part of the configuration data saved in the flash
S-0-1300.0.135		Internal version information of the S stack used
S-0-1300.0.136		Build string with SVN revision and date/clock

12 Startup

Delivery state

By default upon delivery, the following features are available:

sercos address = 55

Reconfiguration button

The reconfiguration button is currently not supported.

sercos address assignment

- There is no switch for setting the sercos address.
- The module supports automatic address assignment for the sercos address.
- The sercos address is stored retentively.



For additional information about automatic address assignment, please refer to the sercos master documentation.

13 IDN list, subdevice 1

The following table lists all implemented sercos parameters (S parameters) with important features.

IDN	Name	Attributes	Default value	Unit	Minimum	Maximum
S-0-0011.0.0	Class 1 diagnostic (C1D)	0x70010001				
S-0-0012.0.0	Class 2 diagnostic (C2D)	0x70010001				
S-0-0014.0.0	Interface status	0x70010001				
S-0-0017.0.0	IDN-list of all operation data	0x70560001				
S-0-0021.0.0	IDN-list of invalid operation data for CP2	0x560001				
S-0-0022.0.0	IDN-list of invalid operation data for CP3	0x560001				
S-0-0025.0.0	IDN-list of all procedure commands	0x70560001				
S-0-0032.0.0	Primary operation mode	0x10001				
S-0-0033.0.0	Secondary operation mode 1	0x10001				
S-0-0036.0.0	Velocity command value	0x1220001		rpm		
S-0-0037.0.0	Additive velocity command value	0x1220001		rpm		
S-0-0038.0.0	Positive velocity limit value	0x1220001		rpm	0	
S-0-0039.0.0	Negative velocity limit value	0x1220001		rpm		0
S-0-0040.0.0	Velocity feedback value 1	0x1220001		rpm		
S-0-0041.0.0	Homing velocity	0x1220001		rpm		
S-0-0042.0.0	Homing acceleration	0x120001		--		
S-0-0043.0.0	Velocity polarity parameter	0x40010001				
S-0-0044.0.0	Velocity data scaling type	0x40010001				
S-0-0045.0.0	Velocity data scaling factor	0x40110001			1	
S-0-0046.0.0	Velocity data scaling exponent	0x40210001				
S-0-0047.0.0	Position command value	0x6220001		deg		
S-0-0051.0.0	Position feedback value 1 (motor feedback)	0x76220001		deg		
S-0-0053.0.0	Position feedback value 2 (external feedback)	0x76220001		deg		
S-0-0060.0.0	Position switch point 1	0x6220001		deg		
S-0-0061.0.0	Position switch point 2	0x6220001		deg		
S-0-0062.0.0	Position switch point 3	0x6220001		deg		
S-0-0063.0.0	Position switch point 4	0x6220001		deg		
S-0-0064.0.0	Position switch point 5	0x6220001		deg		
S-0-0065.0.0	Position switch point 6	0x6220001		deg		
S-0-0066.0.0	Position switch point 7	0x6220001		deg		
S-0-0067.0.0	Position switch point 8	0x6220001		deg		
S-0-0068.0.0	Position switch point 9	0x6220001		deg		
S-0-0069.0.0	Position switch point 10	0x6220001		deg		
S-0-0070.0.0	Position switch point 11	0x6220001		deg		
S-0-0071.0.0	Position switch point 12	0x6220001		deg		
S-0-0072.0.0	Position switch point 13	0x6220001		deg		
S-0-0073.0.0	Position switch point 14	0x6220001		deg		
S-0-0074.0.0	Position switch point 15	0x6220001		deg		
S-0-0075.0.0	Position switch point 16	0x6220001		deg		
S-0-0076.0.0	Position data scaling type	0x40010001				
S-0-0077.0.0	Linear position data scaling type	0x40110001			1	
S-0-0078.0.0	Linear position data scaling exponent	0x40210001				
S-0-0079.0.0	Rotational position resolution	0x40120001			1	
S-0-0080.0.0	Torque command value	0x210001		--		
S-0-0081.0.0	Additive torque command value	0x210001		--		
S-0-0082.0.0	Positive torque limit value	0x210001		--		
S-0-0083.0.0	Negative torque limit value	0x210001		--		
S-0-0084.0.0	Torque feedback value	0x210001		--		

IDN	Name	Attributes	Default value	Unit	Minimum	Maximum
S-0-0086.0.0	Torque/force data scaling type	0x40010001				
S-0-0095.0.0	Diagnostic message	0x70440001				
S-0-0099.0.0	Reset class 1 diagnostic	0x90001			0	0
S-0-0100.0.0	Velocity loop proportional gain	0x120001				
S-0-0101.0.0	Velocity loop integral action time	0x1110001		ms		
S-0-0102.0.0	Velocity loop differential time	0x110001		ms		
S-0-0103.0.0	Modulo value	0x120001		--		
S-0-0104.0.0	Position loop KV-factor	0x110001		m/min		
S-0-0105.0.0	Position loop integral action time	0x110001		ms		
S-0-0106.0.0	Current loop proportional gain 1	0x120001				
S-0-0107.0.0	Current loop integral action time 1	0x110001		µs		
S-0-0108.0.0	Feedrate override	0x110001		%		
S-0-0109.0.0	Motor peak current	0x3120001		A		
S-0-0113.0.0	Maximum motor speed	0x4120001		1/min		
S-0-0115.0.0	Position feedback 2 type	0x10001				
S-0-0116.0.0	Resolution of feedback 1	0x60120001				
S-0-0117.0.0	Resolution of feedback 2	0x60120001				
S-0-0127.0.0	CP3 transition check	0x60090001			0	0
S-0-0128.0.0	CP4 transition check	0x50090001			0	0
S-0-0130.0.0	Probe value 1 positive edge	0x6220001		deg		
S-0-0131.0.0	Probe value 1 negative edge	0x6220001		deg		
S-0-0132.0.0	Probe value 2 positive edge	0x6220001		deg		
S-0-0133.0.0	Probe value 2 negative edge	0x6220001		deg		
S-0-0134.0.0	Drive control	0x310001				
S-0-0135.0.0	Drive status	0x70310001				
S-0-0146.0.0	Control unit controlled homing procedure command	0x90001				
S-0-0147.0.0	Homing parameter	0x10001				
S-0-0148.0.0	Drive controlled homing procedure command	0x90001				
S-0-0169.0.0	Probe control	0x10001				
S-0-0170.0.0	Probing cycle procedure command	0x90001				
S-0-0187.0.0	IDN-list of configurable data in the AT	0x70560001		ID		
S-0-0188.0.0	IDN-list of configurable data in the MDT	0x70560001		ID		
S-0-0192.0.0	IDN-List of all backup operation data	0x70560001				
S-0-0193.0.0	Positioning jerk	0x220001		--		
S-0-0206.0.0	Drive on delay time	0x1110001		ms		
S-0-0207.0.0	Drive off delay time	0x1110001		ms		
S-0-0256.0.0	Multiplication factor 1	0x120001				
S-0-0257.0.0	Multiplication factor 2	0x120001				
S-0-0258.0.0	Target position	0x6220001		deg		
S-0-0259.0.0	Positioning velocity	0x1220001		rpm		
S-0-0260.0.0	Positioning acceleration	0x220001		--		
S-0-0264.0.0	Backup working memory procedure command	0x60090001				
S-0-0267.0.0	Password	0x60440001	PW71949			
S-0-0273.0.0	Maximum drive off delay time	0x1110001		ms		
S-0-0277.0.0	Position feedback 1 type	0x10001				
S-0-0279.0.0	List of password protected data	0x60560001				
S-0-0292.0.0	List of supported operation modes	0x70350001				
S-0-0295.0.0	Drive enable delay time	0x1110001		ms		
S-0-0304.0.0	Real-time status bit 1	0x10001				
S-0-0305.0.0	Allocation of real-time status bit 1	0x520001				
S-0-0306.0.0	Real-time status bit 2	0x10001				
S-0-0307.0.0	Allocation of real-time status bit 2	0x520001				

IDN	Name	Attributes	Default value	Unit	Minimum	Maximum
S-0-0359.0.0	Positioning deceleration	0x220001		--		
S-0-0390.0.0	Diagnostic Number	0x70320001				
S-0-0393.0.0	Command value mode	0x10001				
S-0-0400.0.0	Home switch	0x10001				
S-0-0405.0.0	Probe 1 enable	0x10001				
S-0-0406.0.0	Probe 2 enable	0x10001				
S-0-0409.0.0	Probe 1 positive latched	0x110001				
S-0-0410.0.0	Probe 1 negative latched	0x110001				
S-0-0411.0.0	Probe 2 positive latched	0x110001				
S-0-0412.0.0	Probe 2 negative latched	0x110001				
S-0-0415.0.0	Bit number allocation of real-time status bit 1	0x110001			0	63
S-0-0416.0.0	Bit number allocation of real-time status bit 2	0x110001			0	63
S-0-0417.0.0	Positioning velocity threshold in modulo mode	0x1120001		rpm		
S-0-0418.0.0	Target position window in modulo mode	0x6120001		deg		
S-0-0426.0.0	Measuring data allocation 1	0x520001				
S-0-0427.0.0	Measuring data allocation 2	0x520001				
S-0-0428.0.0	IDN list of configurable measuring data	0x70560001				
S-0-0430.0.0	Active target position	0x6220001		deg		
S-0-0437.0.0	Positioning status	0x10001				
S-0-0440.0.0	Marker position feedback 1	0x6220001		deg		
S-0-0441.0.0	Marker position feedback 2	0x6220001		deg		
S-0-0442.0.0	Counter marker position feedback 1	0x110001				
S-0-0443.0.0	Counter marker position feedback 2	0x110001				
S-0-1000.0.0	SCP Type & Version	0x70350001	0x0201 0x0301 0x0401 0x0501 0x0A01			
S-0-1002.0.0	Cycle time (tScyc)	0x63120001		ns	250000	65000000
S-0-1003.0.0	Allowed MST losses in CP3/CP4	0x60120001				
S-0-1005.0.0	Minimum feedback processing time (t5)	0x73120001		ns		
S-0-1006.0.0	AT transmission starting time (t1)	0x63120001		ns	0	65000000
S-0-1007.0.0	Feedback acquisition capture point (t4)	0x63120001		ns	0	65000000
S-0-1008.0.0	Command value valid time (t3)	0x63120001		ns	0	65000000
S-0-1009.0.0	Device Control	0x60310001				
S-0-1010.0.0	Lengths of MDT	0x60150001				
S-0-1011.0.0	Device Status offset in AT	0x60310001				
S-0-1012.0.0	Lengths of ATs	0x60150001				
S-0-1013.0.0	SVC offset in MDT	0x60310001				
S-0-1014.0.0	SVC offset in AT	0x63310001				
S-0-1015.0.0	Ring delay	0x3120001		ns		1048575
S-0-1016.0.0	Slave delay (P/S)	0x73160001		ns		
S-0-1017.0.0	NRC transmission time	0x63160001		ns		
S-0-1019.0.0	MAC address	0x70340001	00-60-34-xx-xx-xx			
S-0-1020.0.0	IP address	0x140001	149.208.18.209			
S-0-1021.0.0	Subnet mask	0x140001	255.255.0.0			
S-0-1022.0.0	Gateway address	0x140001	0.0.0.0			
S-0-1023.0.0	SYNC jitter	0x63120001		ns		63750
S-0-1024.0.0	SYNC delay measuring procedure command	0x90001			0	0
S-0-1026.0.0	Version of communication hardware	0x70440001				
S-0-1027.0.1	Maximum transmission unit sent within the NRT channel	0x60110001			46	1500
S-0-1027.0.2	Maximum transm	0x70110001			46	1500
S-0-1028.0.0	Error counter MST P/S	0x110001				

IDN	Name	Attributes	Default value	Unit	Minimum	Maximum
S-0-1035.0.0	Error counter Port1 & Port2	0x320001				
S-0-1040.0.0	sercos address	0x110001	55		0	511
S-0-1041.0.0	AT Command value valid time (t9)	0x63120001		µs	0	65000000
S-0-1044.0.0	Device Control	0x70310001				
S-0-1045.0.0	Device Status	0x70310001				
S-0-1046.0.0	List of sercos addresses in device	0x70150001				
S-0-1050.0.1	Configuration of The Connection	0x60310001				
S-0-1050.0.2	Connection Number	0x60110001			0	65535
S-0-1050.0.3	Telegram Assignment	0x60310001				
S-0-1050.0.4	Max. Length of Connection	0x70110001			2	1484
S-0-1050.0.5	Actual Length of Connection	0x70110001				
S-0-1050.0.6	Configuration List	0x60560001				
S-0-1050.0.8	Connection Control (C-Con)	0x10001				
S-0-1050.0.10	Producer Cycle Time	0x63120001		ns	1000000	65000000
S-0-1050.0.11	Allowed Data Losses	0x60110001			1	65535
S-0-1050.0.12	Error Counter Data Losses	0x70110001				
S-0-1050.0.20	IDN allocation of real-time bit	0x560001				
S-0-1050.0.21	Bit allocation of real-time bit	0x150001				
S-0-1050.1.1	Configuration Of The Connection	0x60310001				
S-0-1050.1.2	Connection Number	0x60110001			0	65535
S-0-1050.1.3	Telegram Assignment	0x60310001				
S-0-1050.1.4	Max. Length of Connection	0x70110001			2	1484
S-0-1050.1.5	Actual Length of Connection	0x70110001				
S-0-1050.1.6	Configuration List	0x60560001				
S-0-1050.1.8	Connection Control (C-Con)	0x10001				
S-0-1050.1.10	Producer Cycle Time	0x63120001		ns	1000000	65000000
S-0-1050.1.11	Allowed Data Losses	0x60110001			1	65535
S-0-1050.1.12	Error Counter Data Losses	0x70110001				
S-0-1050.1.20	IDN allocation of real-time bit	0x560001				
S-0-1050.1.21	Bit allocation of real-time bit	0x150001				
S-0-1050.2.1	Configuration of the Connection	0x60310001				
S-0-1050.2.2	Connection Number	0x60110001			0	65535
S-0-1050.2.3	Telegram Assignment	0x60310001				
S-0-1050.2.4	Max. Length of Connection	0x70110001			2	1484
S-0-1050.2.5	Actual Length of Connection	0x70110001				
S-0-1050.2.6	Configuration List	0x60560001				
S-0-1050.2.8	Connection Control (C-Con)	0x10001				
S-0-1050.2.10	Producer Cycle Time	0x63120001		ns	1000000	65000000
S-0-1050.2.11	Allowed Data Losses	0x60110001			1	65535
S-0-1050.2.12	Error Counter Data Losses	0x70110001				
S-0-1050.2.20	IDN allocation of real-time bit	0x560001				
S-0-1050.2.21	Bit allocation of real-time bit	0x150001				
S-0-1050.3.1	Configuration of the Connection	0x60310001				
S-0-1050.3.2	Connection Number	0x60110001			0	65535
S-0-1050.3.3	Telegram Assignment	0x60310001				
S-0-1050.3.4	Max. Length of Connection	0x70110001			2	1484
S-0-1050.3.5	Actual Length of Connection	0x70110001				
S-0-1050.3.6	Configuration List	0x60560001				
S-0-1050.3.8	Connection Control (C-Con)	0x10001				
S-0-1050.3.10	Producer Cycle Time	0x63120001		ns	1000000	65000000
S-0-1050.3.11	Allowed Data Losses	0x60110001			1	65535
S-0-1050.3.12	Error Counter Data Losses	0x70110001				

IDN	Name	Attributes	Default value	Unit	Minimum	Maximum
S-0-1050.3.20	IDN allocation of real-time bit	0x560001				
S-0-1050.3.21	Bit allocation of real-time bit	0x150001				
S-0-1051.0.0	Image of connection setups	0x70350001				
S-0-1300.0.1	Component Name	0x70440001	?			
S-0-1300.0.2	Vendor name	0x70440001	?			
S-0-1300.0.3	Vendor Code	0x70110001	?			
S-0-1300.0.4	Device Name	0x70440001	?			
S-0-1300.0.5	Device ID	0x70440001	?			
S-0-1300.0.6	Connected to sub-device	0x70110001	?		0	511
S-0-1300.0.7	Function Revision	0x70110001	?		0	9999
S-0-1300.0.8	Hardware Revision	0x70440001	?			
S-0-1300.0.9	Software Revision	0x70440001	?			
S-0-1300.0.10	Firmware Loader Revision	0x70440001	?			
S-0-1300.0.11	Order number	0x70440001	?			
S-0-1300.0.12	Serial number	0x70440001	?			
S-0-1300.0.13	Manufacturing Date	0x70440001				
S-0-1300.0.20	Operational Hours	0x70120001		h	0	
S-0-1300.0.128	FPGA register BOARD-ID	0x70310001				
S-0-1300.0.129	FPGA register SYSID-ID	0x70120001				
S-0-1300.0.130	FPGA register SYSID-Timestamp	0x70120001				
S-0-1300.0.131	Configuration data-set identification	0x70440001				
S-0-1300.0.132	Firmware checksum	0x70310001				
S-0-1300.0.133	Firmware filename	0x70440001				
S-0-1300.0.134	INI block content	0x70440001				
S-0-1300.0.135	Slave communication stack	0x70440001				
S-0-1301.0.0	List of GDP Classes & Version	0x70350001	0x0101			
S-0-1302.0.1	FSP Type & Version	0x70320001	0x00010001			
S-0-1302.0.2	Function Groups	0x70560001	S-0-1500.0.0 S-0-1504.1.0 S-0-1505.1.0 S-0-1515.1.0 S-0-1504.2.0 S-0-1505.2.0 S-0-1515.2.0 S-0-1504.3.0 S-0-1505.3.0 S-0-1515.3.0 S-0-1504.4.0 S-0-1505.4.0 S-0-1515.4.0			
S-0-1302.0.3	Application Type	0x440001	Axis			
S-0-1303.0.1	List of Diagnostic Numbers	0x360001				
S-0-1303.0.3	List of faulty Function Groups	0x560001				
S-0-1303.0.4	List of additional diag. Infos	0x50001				
S-0-1500.0.1	IO Control	0x10001				
S-0-1500.0.2	IO Status	0x10001				
S-0-1500.0.3	Module Type Code	0x70370001	?			
S-0-1500.0.5	Container OutputData	0x350001				
S-0-1500.0.9	Container InputData	0x350001				
S-0-1500.0.19	Parameter Channel Receive	0x70340001				
S-0-1500.0.20	Parameter Channel Transmit	0x60340001				
S-0-1500.0.32	IO Diagnosis Message	0xF1				
S-0-1502.0.1	Name of IO_FG	0x440001				
S-0-1502.0.2	Configuration of IO_FG	0x60010001				
S-0-1502.0.3	Channel Quantity PDOOUT	0x70110001	2			

IDN	Name	Attributes	Default value	Unit	Minimum	Maximum
S-0-1502.0.4	Channel Size PDOOUT	0x70110001	1			
S-0-1502.0.5	PDOOUT	0x10001				
S-0-1502.0.19	Parameter Channel Receive	0x70340001				
S-0-1502.0.20	Parameter Channel Transmit	0x70340001				
S-0-1502.0.22	Fall Back Value Output	0x10001				
S-0-1502.0.23	Min. Delay Time	0x70120001		ns		
S-0-1502.0.24	Max. Delay Time	0x70120001		ns		
S-0-1503.0.1	Name of IO_FG	0x440001				
S-0-1503.0.2	Configuration of IO_FG	0x60010001				
S-0-1503.0.7	Channel Quantity PDIN	0x70110001	4			
S-0-1503.0.8	Channel Size PDIN	0x70110001	1			
S-0-1503.0.9	PDIN	0x70010001				
S-0-1503.0.19	Parameter Channel Receive	0x70340001				
S-0-1503.0.20	Parameter Channel Transmit	0x70340001				
S-0-1503.0.23	Min. Delay Time	0x70120001		ns		
S-0-1503.0.24	Max. Delay Time	0x70120001		ns		
S-0-1504.0.1	Name of IO_FG	0x440001				
S-0-1504.0.2	Configuration of IO_FG	0x60010001				
S-0-1504.0.3	Channel Quantity PDOOUT	0x70110001	1			
S-0-1504.0.4	Channel Size PDOOUT	0x70110001	16			
S-0-1504.0.5	PDOOUT	0x110001				
S-0-1504.0.19	Parameter Channel Receive	0x70340001				
S-0-1504.0.20	Parameter Channel Transmit	0x70340001				
S-0-1504.0.22	Fall Back Value Output	0x110001				
S-0-1504.0.23	Min. Delay Time	0x70120001		ns		
S-0-1504.0.24	Max. Delay Time	0x70120001		ns		
S-0-1506.0.1	Name of IO_FG	0x440001				
S-0-1506.0.2	Configuration of IO_FG	0x60010001				
S-0-1506.0.7	Channel Quantity PDIN	0x70110001				
S-0-1506.0.8	Channel Size PDIN	0x70110001				
S-0-1506.0.9	PDIN	0x70120001				
S-0-1506.0.19	Parameter Channel Receive	0x70340001				
S-0-1506.0.20	Parameter Channel Transmit	0x70340001				
S-0-1506.0.23	Min. Delay Time	0x70120001		ns		
S-0-1506.0.24	Max. Delay Time	0x70120001		ns		
P-0-1002.0.1	Reference Input Select	0x20001				
P-0-1002.0.2	Overtemperature Input Select	0x20001				
P-0-1002.0.3	Inverter Error Input Select	0x20001				
P-0-1003.1.1	Logic Position-Switch S-0-0060 for Output 1	0x20001				
P-0-1003.1.2	Logic Position-Switch S-0-0061 for Output 1	0x20001				
P-0-1003.1.3	Logic Position-Switch S-0-0062 for Output 1	0x20001				
P-0-1003.1.4	Logic Position-Switch S-0-0063 for Output 1	0x20001				
P-0-1003.1.5	Logic Position-Switch S-0-0064 for Output 1	0x20001				
P-0-1003.1.6	Logic Position-Switch S-0-0065 for Output 1	0x20001				
P-0-1003.1.7	Logic Position-Switch S-0-0066 for Output 1	0x20001				
P-0-1003.1.8	Logic Position-Switch S-0-0067 for Output 1	0x20001				
P-0-1003.1.9	Logic Position-Switch S-0-0068 for Output 1	0x20001				
P-0-1003.1.10	Logic Position-Switch S-0-0069 for Output 1	0x20001				
P-0-1003.1.11	Logic Position-Switch S-0-0070 for Output 1	0x20001				
P-0-1003.1.12	Logic Position-Switch S-0-0071 for Output 1	0x20001				
P-0-1003.1.13	Logic Position-Switch S-0-0072 for Output 1	0x20001				
P-0-1003.1.14	Logic Position-Switch S-0-0073 for Output 1	0x20001				

IDN	Name	Attributes	Default value	Unit	Minimum	Maximum
P-0-1003.1.15	Logic Position-Switch S-0-0074 for Output 1	0x20001				
P-0-1003.1.16	Logic Position-Switch S-0-0075 for Output 1	0x20001				
P-0-1003.2.1	Logic Position-Switch S-0-0060 for Output 2	0x20001				
P-0-1003.2.2	Logic Position-Switch S-0-0061 for Output 2	0x20001				
P-0-1003.2.3	Logic Position-Switch S-0-0062 for Output 2	0x20001				
P-0-1003.2.4	Logic Position-Switch S-0-0063 for Output 2	0x20001				
P-0-1003.2.5	Logic Position-Switch S-0-0064 for Output 2	0x20001				
P-0-1003.2.6	Logic Position-Switch S-0-0065 for Output 2	0x20001				
P-0-1003.2.7	Logic Position-Switch S-0-0066 for Output 2	0x20001				
P-0-1003.2.8	Logic Position-Switch S-0-0067 for Output 2	0x20001				
P-0-1003.2.9	Logic Position-Switch S-0-0068 for Output 2	0x20001				
P-0-1003.2.10	Logic Position-Switch S-0-0069 for Output 2	0x20001				
P-0-1003.2.11	Logic Position-Switch S-0-0070 for Output 2	0x20001				
P-0-1003.2.12	Logic Position-Switch S-0-0071 for Output 2	0x20001				
P-0-1003.2.13	Logic Position-Switch S-0-0072 for Output 2	0x20001				
P-0-1003.2.14	Logic Position-Switch S-0-0073 for Output 2	0x20001				
P-0-1003.2.15	Logic Position-Switch S-0-0074 for Output 2	0x20001				
P-0-1003.2.16	Logic Position-Switch S-0-0075 for Output 2	0x20001				
P-0-1004.0.1	Select Analogue Output Signal	0x20001				
P-0-1004.0.4	Analogue Output Value	0x72220001		Volt		
P-0-1005.1.1	Select Digital Output Signal 1	0x20001				
P-0-1005.2.1	Select Digital Output Signal 2	0x20001				

14 IDN list, subdevice 2

The following table lists all implemented sercos parameters (S parameters) with important features.

IDN	Name	Attributes	Unit	Minimum	Maximum
S-0-0011.0.0	Class 1 diagnostic (C1D)	0x70010001			
S-0-0012.0.0	Class 2 diagnostic (C2D)	0x70010001			
S-0-0014.0.0	Interface status	0x70010001			
S-0-0017.0.0	IDN-list of all operation data	0x60560001			
S-0-0021.0.0	IDN-list of invalid operation data for CP2	0x560001			
S-0-0022.0.0	IDN-list of invalid operation data for CP3	0x560001			
S-0-0025.0.0	IDN-list of all procedure commands	0x70560001			
S-0-0032.0.0	Primary operation mode	0x10001			
S-0-0033.0.0	Secondary operation mode 1	0x10001			
S-0-0036.0.0	Velocity command value	0x1220001	rpm		
S-0-0037.0.0	Additive velocity command value	0x1220001	rpm		
S-0-0038.0.0	Positive velocity limit value	0x1220001	rpm	0	
S-0-0039.0.0	Negative velocity limit value	0x1220001	rpm		0
S-0-0040.0.0	Velocity feedback value 1	0x1220001	rpm		
S-0-0041.0.0	Homing velocity	0x1220001	rpm		
S-0-0042.0.0	Homing acceleration	0x120001	--		
S-0-0043.0.0	Velocity polarity parameter	0x40010001			
S-0-0044.0.0	Velocity data scaling type	0x40010001			
S-0-0045.0.0	Velocity data scaling factor	0x40110001		1	
S-0-0046.0.0	Velocity data scaling exponent	0x40210001			
S-0-0047.0.0	Position command value	0x6220001	deg		
S-0-0051.0.0	Position feedback value 1 (motor feedback)	0x76220001	deg		
S-0-0053.0.0	Position feedback value 2 (external feedback)	0x76220001	deg		
S-0-0060.0.0	Position switch point 1	0x6220001	deg		
S-0-0061.0.0	Position switch point 2	0x6220001	deg		
S-0-0062.0.0	Position switch point 3	0x6220001	deg		
S-0-0063.0.0	Position switch point 4	0x6220001	deg		
S-0-0064.0.0	Position switch point 5	0x6220001	deg		
S-0-0065.0.0	Position switch point 6	0x6220001	deg		
S-0-0066.0.0	Position switch point 7	0x6220001	deg		
S-0-0067.0.0	Position switch point 8	0x6220001	deg		
S-0-0068.0.0	Position switch point 9	0x6220001	deg		
S-0-0069.0.0	Position switch point 10	0x6220001	deg		
S-0-0070.0.0	Position switch point 11	0x6220001	deg		
S-0-0071.0.0	Position switch point 12	0x6220001	deg		
S-0-0072.0.0	Position switch point 13	0x6220001	deg		
S-0-0073.0.0	Position switch point 14	0x6220001	deg		
S-0-0074.0.0	Position switch point 15	0x6220001	deg		
S-0-0075.0.0	Position switch point 16	0x6220001	deg		
S-0-0076.0.0	Position data scaling type	0x40010001			
S-0-0077.0.0	Linear position data scaling type	0x40110001		1	
S-0-0078.0.0	Linear position data scaling exponent	0x40210001			
S-0-0079.0.0	Rotational position resolution	0x40120001		1	
S-0-0080.0.0	Torque command value	0x210001	--		
S-0-0081.0.0	Additive torque command value	0x210001	--		
S-0-0082.0.0	Positive torque limit value	0x210001	--		
S-0-0083.0.0	Negative torque limit value	0x210001	--		
S-0-0084.0.0	Torque feedback value	0x210001	--		
S-0-0086.0.0	Torque/force data scaling type	0x40010001			

IDN	Name	Attributes	Unit	Minimum	Maximum
S-0-0095.0.0	Diagnostic message	0x70440001			
S-0-0096.0.0	Slave arrangement (SLKN)	0x70310001			
S-0-0097.0.0	Mask class 2 diagnostic	0x10001		0	65535
S-0-0098.0.0	Mask class 3 diagnostic	0x10001		0	65535
S-0-0099.0.0	Reset class 1 diagnostic	0x90001		0	0
S-0-0100.0.0	Velocity loop proportional gain	0x120001			
S-0-0101.0.0	Velocity loop integral action time	0x1110001	ms		
S-0-0102.0.0	Velocity loop differential time	0x110001	ms		
S-0-0103.0.0	Modulo value	0x120001	--		
S-0-0104.0.0	Position loop KV-factor	0x110001	m/min		
S-0-0105.0.0	Position loop integral action time	0x110001	ms		
S-0-0106.0.0	Current loop proportional gain 1	0x120001			
S-0-0107.0.0	Current loop integral action time 1	0x110001	µs		
S-0-0108.0.0	Feedrate override	0x110001	%		
S-0-0109.0.0	Motor peak current	0x3120001	A		
S-0-0113.0.0	Maximum motor speed	0x4120001	1/min		
S-0-0115.0.0	Position feedback 2 type	0x10001			
S-0-0116.0.0	Resolution of feedback 1	0x60120001			
S-0-0117.0.0	Resolution of feedback 2	0x60120001			
S-0-0127.0.0	CP3 transition check	0x60090001		0	0
S-0-0128.0.0	CP4 transition check	0x50090001		0	0
S-0-0130.0.0	Probe value 1 positive edge	0x6220001	deg		
S-0-0131.0.0	Probe value 1 negative edge	0x6220001	deg		
S-0-0132.0.0	Probe value 2 positive edge	0x6220001	deg		
S-0-0133.0.0	Probe value 2 negative edge	0x6220001	deg		
S-0-0134.0.0	Drive control	0x310001			
S-0-0135.0.0	Drive status	0x70310001			
S-0-0146.0.0	Control unit controlled homing procedure command	0x90001			
S-0-0147.0.0	Homing parameter	0x10001			
S-0-0148.0.0	Drive controlled homing procedure command	0x90001			
S-0-0169.0.0	Probe control	0x10001			
S-0-0170.0.0	Probing cycle procedure command	0x90001			
S-0-0187.0.0	IDN-list of configurable data in the AT	0x70560001	ID		
S-0-0188.0.0	IDN-list of configurable data in the MDT	0x70560001	ID		
S-0-0192.0.0	IDN-List of all backup operation data	0x70560001			
S-0-0193.0.0	Positioning jerk	0x220001	--		
S-0-0206.0.0	Drive on delay time	0x1110001	ms		
S-0-0207.0.0	Drive off delay time	0x1110001	ms		
S-0-0256.0.0	Multiplication factor 1	0x120001			
S-0-0257.0.0	Multiplication factor 2	0x120001			
S-0-0258.0.0	Target position	0x6220001	deg		
S-0-0259.0.0	Positioning velocity	0x1220001	rpm		
S-0-0260.0.0	Positioning acceleration	0x220001	--		
S-0-0264.0.0	Backup working memory procedure command	0x60090001			
S-0-0267.0.0	Password	0x60440001			
S-0-0273.0.0	Maximum drive off delay time	0x1110001	ms		
S-0-0277.0.0	Position feedback 1 type	0x10001			
S-0-0279.0.0	List of password protected data	0x60560001			
S-0-0292.0.0	List of supported operation modes	0x70350001			
S-0-0295.0.0	Drive enable delay time	0x1110001	ms		
S-0-0304.0.0	Real-time status bit 1	0x10001			
S-0-0305.0.0	Allocation of real-time status bit 1	0x520001			
S-0-0306.0.0	Real-time status bit 2	0x10001			

IDN	Name	Attributes	Unit	Minimum	Maximum
S-0-0307.0.0	Allocation of real-time status bit 2	0x520001			
S-0-0359.0.0	Positioning deceleration	0x220001	--		
S-0-0390.0.0	Diagnostic Number	0x70320001			
S-0-0393.0.0	Command value mode	0x10001			
S-0-0400.0.0	Home switch	0x10001			
S-0-0405.0.0	Probe 1 enable	0x10001			
S-0-0406.0.0	Probe 2 enable	0x10001			
S-0-0409.0.0	Probe 1 positive latched	0x110001			
S-0-0410.0.0	Probe 1 negative latched	0x110001			
S-0-0411.0.0	Probe 2 positive latched	0x110001			
S-0-0412.0.0	Probe 2 negative latched	0x110001			
S-0-0415.0.0	Bit number allocation of real-time status bit 1	0x110001		0	63
S-0-0416.0.0	Bit number allocation of real-time status bit 2	0x110001		0	63
S-0-0417.0.0	Positioning velocity threshold in modulo mode	0x1120001	rpm		
S-0-0418.0.0	Target position window in modulo mode	0x6120001	deg		
S-0-0426.0.0	Measuring data allocation 1	0x520001			
S-0-0427.0.0	Measuring data allocation 2	0x520001			
S-0-0428.0.0	IDN list of configurable measuring data	0x70560001			
S-0-0430.0.0	Active target position	0x6220001	deg		
S-0-0437.0.0	Positioning status	0x10001			
S-0-0440.0.0	Marker position feedback 1	0x6220001	deg		
S-0-0441.0.0	Marker position feedback 2	0x6220001	deg		
S-0-0442.0.0	Counter marker position feedback 1	0x110001			
S-0-0443.0.0	Counter marker position feedback 2	0x110001			
S-0-1000.0.0	SCP Type & Version	0x70350001			
S-0-1002.0.0	Cycle time (tScyc)	0x63120001	µs	250000	65000000
S-0-1003.0.0	Allowed MST losses in CP3/CP4	0x60120001			
S-0-1005.0.0	Minimum feedback processing time (t5)	0x73120001	ns		
S-0-1006.0.0	AT transmission starting time (t1)	0x63120001	ns	0	65000000
S-0-1007.0.0	Feedback acquisition capture point (t4)	0x63120001	ns	0	65000000
S-0-1008.0.0	Command value valid time (t3)	0x63120001	ns	0	65000000
S-0-1009.0.0	Device Control	0x60310001			
S-0-1010.0.0	Lengths of MDT	0x60150001			
S-0-1011.0.0	Device Status offset in AT	0x60310001			
S-0-1012.0.0	Lengths of ATs	0x60150001			
S-0-1013.0.0	SVC offset in MDT	0x60310001			
S-0-1014.0.0	SVC offset in AT	0x63310001			
S-0-1015.0.0	Ring delay	0x3120001	ns		1048575
S-0-1016.0.0	Slave delay (P/S)	0x73160001	ns		
S-0-1017.0.0	NRC transmission time	0x63160001	ns		
S-0-1019.0.0	MAC address	0x70340001			
S-0-1020.0.0	IP address	0x140001			
S-0-1021.0.0	Subnet mask	0x140001			
S-0-1022.0.0	Gateway address	0x140001			
S-0-1023.0.0	SYNC jitter	0x63120001	ns		63750
S-0-1024.0.0	SYNC delay measuring procedure command	0x90001		0	0
S-0-1026.0.0	Version of communication hardware	0x70440001			
S-0-1027.0.1	Maximum transmission unit sent within the NRT channel	0x60110001		46	1500
S-0-1027.0.2	Maximum transm	0x60110001		46	1500
S-0-1028.0.0	Error counter MST P/S	0x110001			
S-0-1035.0.0	Error counter Port1 & Port2	0x320001			
S-0-1040.0.0	SERCOS address	0x110001		0	511
S-0-1041.0.0	AT Command value valid time (t9)	0x63120001	µs	0	65000000

IDN	Name	Attributes	Unit	Minimum	Maximum
S-0-1044.0.0	Device Control	0x70310001			
S-0-1045.0.0	Device Status	0x70310001			
S-0-1046.0.0	List of sercos addresses in device	0x70150001			
S-0-1050.0.1	Configuration of the Connection	0x60310001			
S-0-1050.0.2	Connection Number	0x60110001		0	65535
S-0-1050.0.3	Telegram Assignment	0x60310001			
S-0-1050.0.4	Max. Length Of Connection	0x70110001		2	1484
S-0-1050.0.5	Actual Length of Connection	0x70110001			
S-0-1050.0.6	Configuration List	0x60560001			
S-0-1050.0.8	Connection Control (C-Con)	0x10001			
S-0-1050.0.10	Producer Cycle Time	0x63120001	ns	1000000	65000000
S-0-1050.0.11	Allowed Data Losses	0x60110001		1	65535
S-0-1050.0.12	Error Counter Data Losses	0x70110001			
S-0-1050.0.20	IDN allocation of real-time bit	0x560001			
S-0-1050.0.21	Bit allocation of real-time bit	0x150001			
S-0-1050.1.1	Configuration Of The Connection	0x60310001			
S-0-1050.1.2	Connection Number	0x60110001		0	65535
S-0-1050.1.3	Telegram Assignment	0x60310001			
S-0-1050.1.4	Max. Length Of Connection	0x70110001		2	1484
S-0-1050.1.5	Actual Length of Connection	0x70110001			
S-0-1050.1.6	Configuration List	0x60560001			
S-0-1050.1.8	Connection Control (C-Con)	0x10001			
S-0-1050.1.10	Producer Cycle Time	0x63120001	ns	1000000	65000000
S-0-1050.1.11	Allowed Data Losses	0x60110001		1	65535
S-0-1050.1.12	Error Counter Data Losses	0x70110001			
S-0-1050.1.20	IDN allocation of real-time bit	0x560001			
S-0-1050.1.21	Bit allocation of real-time bit	0x150001			
S-0-1050.2.1	Configuration Of The Connection	0x60310001			
S-0-1050.2.2	Connection Number	0x60110001		0	65535
S-0-1050.2.3	Telegram Assignment	0x60310001			
S-0-1050.2.4	Max. Length Of Connection	0x70110001		2	1484
S-0-1050.2.5	Actual Length of Connection	0x70110001			
S-0-1050.2.6	Configuration List	0x60560001			
S-0-1050.2.8	Connection Control (C-Con)	0x10001			
S-0-1050.2.10	Producer Cycle Time	0x63120001	ns	1000000	65000000
S-0-1050.2.11	Allowed Data Losses	0x60110001		1	65535
S-0-1050.2.12	Error Counter Data Losses	0x70110001			
S-0-1050.2.20	IDN allocation of real-time bit	0x560001			
S-0-1050.2.21	Bit allocation of real-time bit	0x150001			
S-0-1050.3.1	Configuration Of The Connection	0x60310001			
S-0-1050.3.2	Connection Number	0x60110001		0	65535
S-0-1050.3.3	Telegram Assignment	0x60310001			
S-0-1050.3.4	Max. Length Of Connection	0x70110001		2	1484
S-0-1050.3.5	Actual Length of Connection	0x70110001			
S-0-1050.3.6	Configuration List	0x60560001			
S-0-1050.3.8	Connection Control (C-Con)	0x10001			
S-0-1050.3.10	Producer Cycle Time	0x63120001	ns	1000000	65000000
S-0-1050.3.11	Allowed Data Losses	0x60110001		1	65535
S-0-1050.3.12	Error Counter Data Losses	0x70110001			
S-0-1050.3.20	IDN allocation of real-time bit	0x560001			
S-0-1050.3.21	Bit allocation of real-time bit	0x150001			
S-0-1051.0.0	Image of connection setups	0x70350001			
S-0-1300.0.1	Component Name	0x70440001			

IDN	Name	Attributes	Unit	Minimum	Maximum
S-0-1300.0.2	Vendor name	0x70440001			
S-0-1300.0.3	Vendor Code	0x70110001			
S-0-1300.0.4	Device Name	0x70440001			
S-0-1300.0.5	Device ID	0x70440001			
S-0-1300.0.6	Connected to sub-device	0x70110001		0	511
S-0-1300.0.7	Function Revision	0x70110001		0	9999
S-0-1300.0.8	Hardware Revision	0x70440001			
S-0-1300.0.9	Software Revision	0x70440001			
S-0-1300.0.10	Firmware Loader Revision	0x70440001			
S-0-1300.0.11	Order number	0x70440001			
S-0-1300.0.12	Serial number	0x70440001			
S-0-1300.0.13	Manufacturing Date	0x70440001			
S-0-1300.0.20	Operational Hours	0x70120001	h	0	
S-0-1301.0.0	List of GDP Classes & Version	0x70350001			
S-0-1302.0.1	FSP Type & Version	0x70320001			
S-0-1302.0.2	Function Groups	0x70560001			
S-0-1302.0.3	Application Type	0x440001			
S-0-1303.0.1	List of Diagnostic Numbers	0x360001			
S-0-1303.0.3	List of faulty Function Groups	0x560001			
S-0-1303.0.4	List of additional diag. Infos	0x50001			
S-0-1500.0.1	IO Control	0x10001			
S-0-1500.0.2	IO Status	0x10001			
S-0-1500.0.3	Module Type Code	0x70370001			
S-0-1500.0.5	Container OutputData	0x350001			
S-0-1500.0.9	Container InputData	0x350001			
S-0-1500.0.19	Parameter Channel Receive	0x70340001			
S-0-1500.0.20	Parameter Channel Transmit	0x60340001			
S-0-1500.0.32	IO Diagnosis Message	0xEC			
S-0-1502.0.1	Name of IO_FG	0x440001			
S-0-1502.0.2	Configuration of IO_FG	0x60010001			
S-0-1502.0.3	Channel Quantity PDOOUT	0x70110001			
S-0-1502.0.4	Channel Size PDOOUT	0x70110001			
S-0-1502.0.5	PDOOUT	0x10001			
S-0-1502.0.19	Parameter Channel Receive	0x70340001			
S-0-1502.0.20	Parameter Channel Transmit	0x70340001			
S-0-1502.0.22	Fall Back Value Output	0x10001			
S-0-1502.0.23	Min. Delay Time	0x70120001	ns		
S-0-1502.0.24	Max. Delay Time	0x70120001	ns		
S-0-1503.0.1	Name of IO_FG	0x440001			
S-0-1503.0.2	Configuration of IO_FG	0x60010001			
S-0-1503.0.7	Channel Quantity PDIN	0x70110001			
S-0-1503.0.8	Channel Size PDIN	0x70110001			
S-0-1503.0.9	PDIN	0x70010001			
S-0-1503.0.19	Parameter Channel Receive	0x70340001			
S-0-1503.0.20	Parameter Channel Transmit	0x70340001			
S-0-1503.0.23	Min. Delay Time	0x70120001	ns		
S-0-1503.0.24	Max. Delay Time	0x70120001	ns		
S-0-1504.0.1	Name of IO_FG	0x440001			
S-0-1504.0.2	Configuration of IO_FG	0x60010001			
S-0-1504.0.3	Channel Quantity PDOOUT	0x70110001			
S-0-1504.0.4	Channel Size PDOOUT	0x70110001			
S-0-1504.0.5	PDOOUT	0x110001			
S-0-1504.0.19	Parameter Channel Receive	0x70340001			

IDN	Name	Attributes	Unit	Minimum	Maximum
S-0-1504.0.20	Parameter Channel Transmit	0x70340001			
S-0-1504.0.22	Fall Back Value Output	0x110001			
S-0-1504.0.23	Min. Delay Time	0x70120001	ns		
S-0-1504.0.24	Max. Delay Time	0x70120001	ns		
S-0-1506.0.1	Name of IO_FG	0x440001			
S-0-1506.0.2	Configuration of IO_FG	0x60010001			
S-0-1506.0.7	Channel Quantity PDIN	0x70110001			
S-0-1506.0.8	Channel Size PDIN	0x70110001			
S-0-1506.0.9	PDIN	0x70120001			
S-0-1506.0.19	Parameter Channel Receive	0x70340001			
S-0-1506.0.20	Parameter Channel Transmit	0x70340001			
S-0-1506.0.23	Min. Delay Time	0x70120001	ns		
S-0-1506.0.24	Max. Delay Time	0x70120001	ns		
P-0-1002.0.1	Reference Input Select	0x20001			
P-0-1002.0.2	Overtemperature Input Select	0x20001			
P-0-1002.0.3	Inverter Error Input Select	0x20001			
P-0-1003.1.1	Logic Position-Switch S-0-0060 for Output 1	0x20001			
P-0-1003.1.2	Logic Position-Switch S-0-0061 for Output 1	0x20001			
P-0-1003.1.3	Logic Position-Switch S-0-0062 for Output 1	0x20001			
P-0-1003.1.4	Logic Position-Switch S-0-0063 for Output 1	0x20001			
P-0-1003.1.5	Logic Position-Switch S-0-0064 for Output 1	0x20001			
P-0-1003.1.6	Logic Position-Switch S-0-0065 for Output 1	0x20001			
P-0-1003.1.7	Logic Position-Switch S-0-0066 for Output 1	0x20001			
P-0-1003.1.8	Logic Position-Switch S-0-0067 for Output 1	0x20001			
P-0-1003.1.9	Logic Position-Switch S-0-0068 for Output 1	0x20001			
P-0-1003.1.10	Logic Position-Switch S-0-0069 for Output 1	0x20001			
P-0-1003.1.11	Logic Position-Switch S-0-0070 for Output 1	0x20001			
P-0-1003.1.12	Logic Position-Switch S-0-0071 for Output 1	0x20001			
P-0-1003.1.13	Logic Position-Switch S-0-0072 for Output 1	0x20001			
P-0-1003.1.14	Logic Position-Switch S-0-0073 for Output 1	0x20001			
P-0-1003.1.15	Logic Position-Switch S-0-0074 for Output 1	0x20001			
P-0-1003.1.16	Logic Position-Switch S-0-0075 for Output 1	0x20001			
P-0-1003.2.1	Logic Position-Switch S-0-0060 for Output 2	0x20001			
P-0-1003.2.2	Logic Position-Switch S-0-0061 for Output 2	0x20001			
P-0-1003.2.3	Logic Position-Switch S-0-0062 for Output 2	0x20001			
P-0-1003.2.4	Logic Position-Switch S-0-0063 for Output 2	0x20001			
P-0-1003.2.5	Logic Position-Switch S-0-0064 for Output 2	0x20001			
P-0-1003.2.6	Logic Position-Switch S-0-0065 for Output 2	0x20001			
P-0-1003.2.7	Logic Position-Switch S-0-0066 for Output 2	0x20001			
P-0-1003.2.8	Logic Position-Switch S-0-0067 for Output 2	0x20001			
P-0-1003.2.9	Logic Position-Switch S-0-0068 for Output 2	0x20001			
P-0-1003.2.10	Logic Position-Switch S-0-0069 for Output 2	0x20001			
P-0-1003.2.11	Logic Position-Switch S-0-0070 for Output 2	0x20001			
P-0-1003.2.12	Logic Position-Switch S-0-0071 for Output 2	0x20001			
P-0-1003.2.13	Logic Position-Switch S-0-0072 for Output 2	0x20001			
P-0-1003.2.14	Logic Position-Switch S-0-0073 for Output 2	0x20001			
P-0-1003.2.15	Logic Position-Switch S-0-0074 for Output 2	0x20001			
P-0-1003.2.16	Logic Position-Switch S-0-0075 for Output 2	0x20001			
P-0-1004.0.1	Select Analogue Output Signal	0x20001			
P-0-1004.0.4	Analogue Output Value	0x72220001	Volt		
P-0-1005.1.1	Select Digital Output Signal 1	0x20001			
P-0-1005.2.1	Select Digital Output Signal 2	0x20001			

15 Parameter descriptions

P-0-1002.0.1: Reference Input Select

Name		Reference Input Select
Attributes	Length (Octet)	4
	Data Type and Display Format	Binary
	Function	Parameters
	Decimal Point	n/a
	Write Protection	n/a
	Conversion Factor	1
Unit		n/a
Minimum Value		n/a
Maximum Value		n/a
Scaling / Resolution		No
Structure of reference input select		
Bit 0 to bit 3	0000 No input	
	0001 - Digital input 1	
	0010 - Digital input 2	
	0011 - Digital input 3	
	0100 - Digital input 4	

P-0-1002.0.2: Over-Temperature Input Select

Name		Over-Temperature Input Select
Attributes	Length (Octet)	4
	Data Type and Display Format	Binary
	Function	Parameters
	Decimal Point	n/a
	Write Protection	n/a
	Conversion Factor	1
Unit		n/a
Minimum Value		n/a
Maximum Value		n/a
Scaling / Resolution		No
Structure of overtemperature input select (The input is LOW active!)		
Bit 0 to bit 3	0000 No input	
	0001 - Digital input 1	
	0010 - Digital input 2	
	0011 - Digital input 3	
	0100 - Digital input 4	

P-0-1002.0.3: Generic Driver Error Input Select

Name		Generic Driver Error Input Select
Attributes	Length (Octet)	4
	Data Type and Display Format	Binary
	Function	Parameters
	Decimal Point	n/a
	Write Protection	n/a
	Conversion Factor	1
Unit		n/a
Minimum Value		n/a
Maximum Value		n/a
Scaling / Resolution		No
Structure of Generic Driver Error Input Select (Input is LOW active!)		
Bit 0 to bit 3	0000 No input	
	0001 - Digital input 1	
	0010 - Digital input 2	
	0011 - Digital input 3	
	0100 - Digital input 4	

P-0-1003.0.1: Logic Position-Switch S-0-0060 for Output x

Name		Logic Position-Switch S-0-0060 for Output x
Attributes	Length (Octet)	4
	Data Type and Display Format	Binary
	Function	Parameters
	Decimal Point	n/a
	Write Protection	n/a
	Conversion Factor	1
Unit		n/a
Minimum Value		n/a
Maximum Value		n/a
Scaling / Resolution		No
Structure of Logic Position-Switch S-0-0060 for Output x		
Bit 0 to bit 1	00 - No response	
	01 - Reset output	
	10 - Set output	
	11 - Invert output	

P-0-1003.0.2: Logic Position-Switch S-0-0061 for Output x

Name			Logic Position-Switch S-0-0061 for Output x		
Attributes	Length (Octet)			4	
	Data Type and Display Format			Binary	
	Function			Parameters	
	Decimal Point			n/a	
	Write Protection			n/a	
	Conversion Factor			1	
Unit			n/a		
Minimum Value			n/a		
Maximum Value			n/a		
Scaling / Resolution			No		
Structure of Logic Position-Switch S-0-0061 for Output x					
Bit 0 to bit 1	00 - No response				
	01 - Reset output				
	10 - Set output				
	11 - Invert output				

P-0-1003.0.4: Logic Position-Switch S-0-0063 for Output x

Name			Logic Position-Switch S-0-0063 for Output x		
Attributes	Length (Octet)			4	
	Data Type and Display Format			Binary	
	Function			Parameters	
	Decimal Point			n/a	
	Write Protection			n/a	
	Conversion Factor			1	
Unit			n/a		
Minimum Value			n/a		
Maximum Value			n/a		
Scaling / Resolution			No		
Structure of Logic Position-Switch S-0-0063 for Output x					
Bit 0 to bit 1	00 - No response				
	01 - Reset output				
	10 - Set output				
	11 - Invert output				

P-0-1003.0.3: Logic Position-Switch S-0-0062 for Output x

Name			Logic Position-Switch S-0-0062 for Output x		
Attributes	Length (Octet)			4	
	Data Type and Display Format			Binary	
	Function			Parameters	
	Decimal Point			n/a	
	Write Protection			n/a	
	Conversion Factor			1	
Unit			n/a		
Minimum Value			n/a		
Maximum Value			n/a		
Scaling / Resolution			No		
Structure of Logic Position-Switch S-0-0062 for Output x					
Bit 0 to bit 1	00 - No response				
	01 - Reset output				
	10 - Set output				
	11 - Invert output				

P-0-1003.0.5: Logic Position-Switch S-0-0064 for Output x

Name			Logic Position-Switch S-0-0064 for Output x		
Attributes	Length (Octet)			4	
	Data Type and Display Format			Binary	
	Function			Parameters	
	Decimal Point			n/a	
	Write Protection			n/a	
	Conversion Factor			1	
Unit			n/a		
Minimum Value			n/a		
Maximum Value			n/a		
Scaling / Resolution			No		
Structure of Logic Position-Switch S-0-0064 for Output x					
Bit 0 to bit 1	00 - No response				
	01 - Reset output				
	10 - Set output				
	11 - Invert output				

P-0-1003.0.6: Logic Position-Switch S-0-0065 for Output x

Name		Logic Position-Switch S-0-0065 for Output x	
Attributes	Length (Octet)	4	
	Data Type and Display Format	Binary	
	Function	Parameters	
	Decimal Point	n/a	
	Write Protection	n/a	
	Conversion Factor	1	
Unit		n/a	
Minimum Value		n/a	
Maximum Value		n/a	
Scaling / Resolution		No	
Structure of Logic Position-Switch S-0-0065 for Output x			
Bit 0 to bit 1	00 - No response		
	01 - Reset output		
	10 - Set output		
	11 - Invert output		

P-0-1003.0.8: Logic Position-Switch S-0-0067 for Output x

Name		Logic Position-Switch S-0-0067 for Output x	
Attributes	Length (Octet)	4	
	Data Type and Display Format	Binary	
	Function	Parameters	
	Decimal Point	n/a	
	Write Protection	n/a	
	Conversion Factor	1	
Unit		n/a	
Minimum Value		n/a	
Maximum Value		n/a	
Scaling / Resolution		No	
Structure of Logic Position-Switch S-0-0067 for Output x			
Bit 0 to bit 1	00 - No response		
	01 - Reset output		
	10 - Set output		
	11 - Invert output		

P-0-1003.0.7: Logic Position-Switch S-0-0066 for Output x

Name		Logic Position -SwitchS-0-0066 for Output x	
Attributes	Length (Octet)	4	
	Data Type and Display Format	Binary	
	Function	Parameters	
	Decimal Point	n/a	
	Write Protection	n/a	
	Conversion Factor	1	
Unit		n/a	
Minimum Value		n/a	
Maximum Value		n/a	
Scaling / Resolution		No	
Structure of Logic Position-Switch S-0-0066 for Output x			
Bit 0 to bit 1	00 - No response		
	01 - Reset output		
	10 - Set output		
	11 - Invert output		

P-0-1003.0.9: Logic Position-Switch S-0-0068 for Output x

Name		Logic Position-Switch S-0-0068 for Output x	
Attributes	Length (Octet)	4	
	Data Type and Display Format	Binary	
	Function	Parameters	
	Decimal Point	n/a	
	Write Protection	n/a	
	Conversion Factor	1	
Unit		n/a	
Minimum Value		n/a	
Maximum Value		n/a	
Scaling / Resolution		No	
Structure of Logic Position-Switch S-0-0068 for Output x			
Bit 0 to bit 1	00 - No response		
	01 - Reset output		
	10 - Set output		
	11 - Invert output		

P-0-1003.0.10: Logic Position-Switch S-0-0069 for Output x

Name		Logic Position-Switch S-0-0069 for Output x
Attributes	Length (Octet)	4
	Data Type and Display Format	Binary
	Function	Parameters
	Decimal Point	n/a
	Write Protection	n/a
	Conversion Factor	1
Unit		n/a
Minimum Value		n/a
Maximum Value		n/a
Scaling / Resolution		No
Structure of Logic Position-Switch S-0-0069 for Output x		
Bit 0 to bit 1	00 - No response	
	01 - Reset output	
	10 - Set output	
	11 - Invert output	

P-0-1003.0.12: Logic Position-Switch S-0-0071 for Output x

Name		Logic Position -Switch S-0-0071 for Output x
Attributes	Length (Octet)	4
	Data Type and Display Format	Binary
	Function	Parameters
	Decimal Point	n/a
	Write Protection	n/a
	Conversion Factor	1
Unit		n/a
Minimum Value		n/a
Maximum Value		n/a
Scaling / Resolution		No
Structure of Logic Position-Switch S-0-0071 for Output x		
Bit 0 to bit 1	00 - No response	
	01 - Reset output	
	10 - Set output	
	11 - Invert output	

P-0-1003.0.11: Logic Position-Switch S-0-0070 for Output x

Name		Logic Position-Switch S-0-0070 for Output x
Attributes	Length (Octet)	4
	Data Type and Display Format	Binary
	Function	Parameters
	Decimal Point	n/a
	Write Protection	n/a
	Conversion Factor	1
Unit		n/a
Minimum Value		n/a
Maximum Value		n/a
Scaling / Resolution		No
Structure of Logic Position-Switch S-0-0070 for Output x		
Bit 0 to bit 1	00 - No response	
	01 - Reset output	
	10 - Set output	
	11 - Invert output	

P-0-1003.0.13: Logic Position-Switch S-0-0072 for Output x

Name		Logic Position-Switch S-0-0072 for Output x
Attributes	Length (Octet)	4
	Data Type and Display Format	Binary
	Function	Parameters
	Decimal Point	n/a
	Write Protection	n/a
	Conversion Factor	1
Unit		n/a
Minimum Value		n/a
Maximum Value		n/a
Scaling / Resolution		No
Structure of Logic Position-Switch S-0-0072 for Output x		
Bit 0 to bit 1	00 - No response	
	01 - Reset output	
	10 - Set output	
	11 - Invert output	

P-0-1003.0.14: Logic Position-Switch S-0-0073 for Output x

Name		Logic Position-Switch S-0-0073 for Output x	
Attributes	Length (Octet)	4	
	Data Type and Display Format	Binary	
	Function	Parameters	
	Decimal Point	n/a	
	Write Protection	n/a	
	Conversion Factor	1	
Unit		n/a	
Minimum Value		n/a	
Maximum Value		n/a	
Scaling / Resolution		No	
Structure of Logic Position-Switch S-0-0073 for Output x			
Bit 0 to bit 1	00 - No response		
	01 - Reset output		
	10 - Set output		
	11 - Invert output		

P-0-1003.0.16: Logic Position-Switch S-0-0075 for Output x

Name		Logic Position-Switch S-0-0075 for Output x	
Attributes	Length (Octet)	4	
	Data Type and Display Format	Binary	
	Function	Parameters	
	Decimal Point	n/a	
	Write Protection	n/a	
	Conversion Factor	1	
Unit		n/a	
Minimum Value		n/a	
Maximum Value		n/a	
Scaling / Resolution		No	
Structure of Logic Position-Switch S-0-0075 for Output x			
Bit 0 to bit 1	00 - No response		
	01 - Reset output		
	10 - Set output		
	11 - Invert output		

P-0-1003.0.15: Logic Position-Switch S-0-0073 for Output x

Name		Logic Position-Switch S-0-0074 for Output x	
Attributes	Length (Octet)	4	
	Data Type and Display Format	Binary	
	Function	Parameters	
	Decimal Point	n/a	
	Write Protection	n/a	
	Conversion Factor	1	
Unit		n/a	
Minimum Value		n/a	
Maximum Value		n/a	
Scaling / Resolution		No	
Structure of Logic Position-Switch S-0-0074 for Output x			
Bit 0 to bit 1	00 - No response		
	01 - Reset output		
	10 - Set output		
	11 - Invert output		

P-0-1004.0.1: Select Analog Output Signal

Name		
Attributes	Length (Octet)	4
	Data Type and Display Format	Binary
	Function	Parameters
	Decimal Point	n/a
	Write Protection	n/a
	Conversion Factor	1
Unit		n/a
Minimum Value		n/a
Maximum Value		n/a
Scaling / Resolution		No
Structure of Select Analog Output Signal		
Bit 0 to bit 3	0000 - Output 0 V	
	0001 - Speed setpoint output (after homing)	
	0010 - Output S-0-0036.0.0	
	0011 - Output S-0-0037.0.0	
	0100 - Output S-0-0036.0.0 + S-0-0037.0.0	
	0101 - Output S-0-0080.0.0	
	0110 - Output S-0-0081.0.0	
	0111 - Output S-0-0080.0.0 + S-0-0081.0.0	
	1000 - Output S-0-0040.0.0	
	1001 - Output S-0-1504.0.5	

P-0-1005.1.1: Select Digital Output Signal 1

Name		
Attributes	Length (Octet)	4
	Data Type and Display Format	Binary
	Function	Parameters
	Decimal Point	n/a
	Write Protection	n/a
	Conversion Factor	1
Unit		n/a
Minimum Value		n/a
Maximum Value		n/a
Scaling / Resolution		No
Structure of Select Digital Output Signal 1		
Bit 0 to bit 3	0000 - Output FALSE	
	0001 - Output TRUE	
	0010 - Output logic position switch 1	
	0011 - Output S-0-0304.0.0	
	0100 - Output S-0-0306.0.0	
	0100 - Output S-0-0306.0.0	
	0101 - Output S-0-1502.0.5	
	0110 - Bit 14/15 from IDN/S-0-0134 (Bit14 and Bit15 = OUT1)	

P-0-1004.0.2: Analog Output Value

To read the controller outputs (if switched as such)

Name		
Attributes	Length (Octet)	4
	Data Type and Display Format	Signed32
	Function	Parameters
	Decimal Point	2
	Write Protection	Yes
	Conversion Factor	0.01
Unit		n/a
Minimum Value		-10.00
Maximum Value		10.00
Scaling / Resolution		0.01

P-0-1005.2.1: Select Digital Output Signal 2

Name		Select Digital Output Signal 2
Attributes	Length (Octet)	4
	Data Type and Display Format	Binary
	Function	Parameters
	Decimal Point	n/a
	Write Protection	n/a
	Conversion Factor	1
Unit		n/a
Minimum Value		n/a
Maximum Value		n/a
Scaling / Resolution		No
Structure of Select Digital Output Signal 2		
Bit 0 to bit 3	0000 - Output FALSE	
	0001 - Output TRUE	
	0010 - Output logic position switch 2	
	0011 - Output S-0-0304.0.0	
	0100 - Output S-0-0306.0.0	
	0100 - Output S-0-0306.0.0	
	0101 - Output S-0-1502.0.5	
	0110 - Bit 14/15 from IDN/S-0-0134 (Bit14 and Bit15 = OUT2)	

Компания «Life Electronics» занимается поставками электронных компонентов импортного и отечественного производства от производителей и со складов крупных дистрибьюторов Европы, Америки и Азии.

С конца 2013 года компания активно расширяет линейку поставок компонентов по направлению коаксиальный кабель, кварцевые генераторы и конденсаторы (керамические, пленочные, электролитические), за счёт заключения дистрибьюторских договоров

Мы предлагаем:

- Конкурентоспособные цены и скидки постоянным клиентам.
- Специальные условия для постоянных клиентов.
- Подбор аналогов.
- Поставку компонентов в любых объемах, удовлетворяющих вашим потребностям.
- Приемлемые сроки поставки, возможна ускоренная поставка.
- Доставку товара в любую точку России и стран СНГ.
- Комплексную поставку.
- Работу по проектам и поставку образцов.
- Формирование склада под заказчика.
- Сертификаты соответствия на поставляемую продукцию (по желанию клиента).
- Тестирование поставляемой продукции.
- Поставку компонентов, требующих военную и космическую приемку.
- Входной контроль качества.
- Наличие сертификата ISO.

В составе нашей компании организован Конструкторский отдел, призванный помогать разработчикам, и инженерам.

Конструкторский отдел помогает осуществить:

- Регистрацию проекта у производителя компонентов.
- Техническую поддержку проекта.
- Защиту от снятия компонента с производства.
- Оценку стоимости проекта по компонентам.
- Изготовление тестовой платы монтаж и пусконаладочные работы.



Тел: +7 (812) 336 43 04 (многоканальный)

Email: org@lifeelectronics.ru