

SE-134C MANUAL
GROUND-FAULT GROUND-CHECK MONITOR
REVISION 7-D-090816

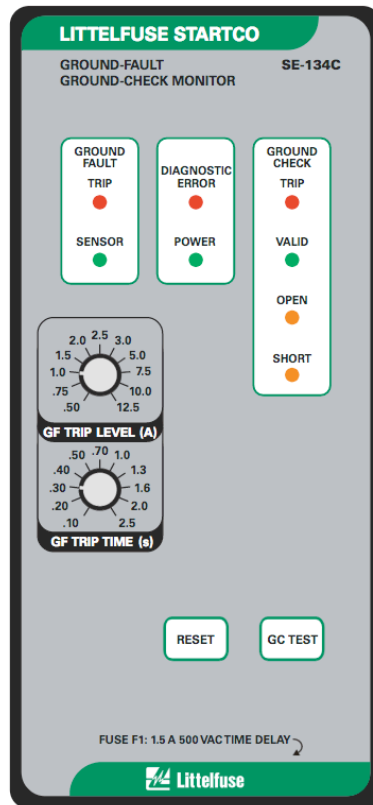

Copyright © 2016 by Littelfuse Startco.

All rights reserved.

This page intentionally left blank.

TABLE OF CONTENTS

SECTION	PAGE
1 General	1
2 Operation	1
2.1 Ground-Fault Circuit	1
2.1.1 GF Trip Time Setting	1
2.1.2 GF Trip Level Setting	1
2.2 Ground-Check Circuit	1
2.3 Reset	2
2.4 Trip Relay	2
3 Indication	2
3.1 Ground Fault	2
3.2 Power	2
3.3 Diagnostic Error	2
3.4 Ground Check	2
4 Installation	2
4.1 General	2
4.2 Monitor	3
4.3 Current Sensors	3
4.4 Termination Assembly	3
4.5 Remote Operation	3
4.6 Parallel-Path Isolation	3
4.7 Ferrite Placement.....	3
5 Technical Specifications	15
5.1 SE-134C	15
5.2 Current Sensors	16
5.3 Termination Assemblies	17
6 Ordering Information	17
7 Warranty	18
8 Test Procedures	18
8.1 Ground-Check Trip Tests	18
8.1.1 Latching Ground-Check Trip Test.....	18
8.1.2 Non-Latching Ground-Check Trip Test...	18
8.2 Trip Relay Fail-Safe Mode Test.....	18
8.3 Current-Sensor-Verification Test	18
8.4 SE-TA6A-Series Termination Assembly Tests ..	19
8.5 Ground-Fault Performance Test	19
Appendix A SE-134C Revision History	22

LIST OF FIGURES

FIGURE	PAGE
1 SE-134C Typical Application	4
2 SE-134C Outline and Panel-Mounting Details	5
3 SE-134-SMA Surface Mount Adapter and SE-134C Surface-Mounting Details	6
4 SE-IP65CVR-G Weatherproof Cover Outline	7
5 SE-IP65CVR-G Weatherproof Cover Installation.....	8
6 SE-CS10 Current Sensors	9
7 SE-TA6A and SE-TA6A-WL Termination Assemblies	10
8 SE-TA6ASF-WL Small-Format-Wire-Lead Termination Assembly	11
9 RK-132 Remote Indication and Reset Kit	11
10 PPI-600V Parallel-Path Isolator	12
11 PPI-600V Typical Installation	13
12 SE-134C with Ferrites Installed	14
13 Current Sensor Shield Connection	14
14 Trip Relay Maximum Switching Capacity	20
15 Remote-Indication Relays GC and GF Maximum Switching Capacity	20
16 Ground-Fault-Test Circuit.....	21
17 Termination-Assembly-Test Circuits	21

LIST OF TABLES

TABLE	PAGE
1 Ground-Fault-Test Record	19

DISCLAIMER

Specifications are subject to change without notice. Littelfuse Startco is not liable for contingent or consequential damages, or for expenses sustained as a result of incorrect application, incorrect adjustment, or a malfunction.

This page intentionally left blank.

1. GENERAL

The SE-134C is a microprocessor-based, combination ground-fault and ground-wire monitor for resistance-grounded systems. It has a switching power supply that accepts a wide range of ac and dc voltages, and its specifications apply over an industrial temperature range at high humidity. The SE-134C meets the IEEE surge-withstand-capability tests (oscillatory and fast transient) for protective relays and relay systems. Isolated, normally open and normally closed contacts are provided for contactor control or for shunt or undervoltage operation in a breaker-trip circuit. All operating conditions are clearly annunciated and two Form C contacts are provided for remote indication. The SE-134C is housed in an anodized extruded-aluminum enclosure, and all connections are made with plug-in, wire-clamping terminal blocks. Provision is made for both panel and surface mounting.

The ground-fault circuit detects fundamental-frequency, zero-sequence current with a window-type current sensor and it verifies that the current sensor is connected and not shorted. A definite-time characteristic with 11 trip levels and 11 trip times allows coordination in virtually any resistance-grounded system. Although other current sensors may satisfy the verification circuit, only SE-CS10-series sensors have characteristics that meet system specifications. Current-sensor verification can be disabled for a ground-check-only application.

The ground-check circuit has an open-circuit voltage of 24 Vdc, which is not a hazard to personnel, and it has an output drive current above 100 mA for optimum performance in slip-ring, commutated-load, and high-induced-ac applications. Features include an externally accessible ground-check fuse, a resistance-insertion test, 3-kV isolation between the ground-check loop and the monitor electronics, and a PPI-600V accessory for parallel-ground-path rejection. A PPI-600V will also eliminate intermachine arcing and prevent stray ac and dc currents from flowing in the monitored ground wire. Unlike ground-check circuits using other termination devices, and especially those with phase-reversal switches, a ground-check circuit using a termination device with a Zener characteristic is capable of loop measurements that are independent of current in the phase conductors. The SE-134C ground-check circuit recognizes the SE-TA6A-series 5.6-volt Zener characteristic as a valid end-of-line completion. This is the only passive characteristic that will satisfy the ground-check circuit's multi-level drive, allow induced currents to circulate in the ground-check loop, survive a phase-to-ground-check fault, and clamp the ground-check voltage during the fault. Although a standard 5.6-volt Zener diode may engage the SE-134C's ground-check circuit, only an SE-TA6A-series termination assembly has the compensation required to meet system specifications. In

select applications, a combination of an SE-TA12A and SE-TA12B Termination Assembly can be used to monitor the cables of a splitter box (junction box) using a single SE-134C Monitor. The SE-TA12A/SE-TA12B combination is not compatible with the SE-134C-XGC-X0 ordering option. See Technical Note GC-09, available at www.littelfuse.com/relayscontrols.

2. OPERATION

2.1 GROUND-FAULT CIRCUIT

2.1.1 GF TRIP TIME SETTING

The ground-fault circuit has a definite-time characteristic with 11 settings from 0.1 to 2.5 seconds. Time-coordinated ground-fault protection requires the trip time to be longer than the trip time of downstream ground-fault devices.

2.1.2 GF TRIP LEVEL SETTING

The trip level of the ground-fault circuit is switch selectable with 11 settings from 0.5 to 12.5 A. A minimum tripping ratio of 5 is recommended to achieve at least 80% winding protection, and this requires the trip level to be no more than 20% of the grounding-resistor let-through current. A ground-fault trip is latched, requiring a reset. A current-sensor failure will also cause a ground-fault trip. See Section 3.1

If the SE-134C is operated in a ground-check-only application and an SE-CS10 is not connected, connect terminals 17 and 18 to disable sensor verification. See Fig. 1.

2.2 GROUND-CHECK CIRCUIT

The ground-check loop consists of the outgoing ground-check conductor, quick-coupler connections, the SE-TA6A-series termination assembly, the SE-TA6A connection to equipment frame or ground bus, the ground-return path, and the SE-134C cable-ground-terminal connection to substation ground.

The SE-134C detects a valid ground-check loop when an SE-TA6A-series termination assembly is detected in the loop and loop resistance is less than 28 ohms (45 ohms for XGC option). The loop is not valid if open (or high resistance), or if the ground-check conductor is shorted to ground.

When the ground-check loop is valid, the SE-134C ground-check circuit can be tested by pressing the GC TEST button or by shorting GC TEST terminals 11 and 12. This test invalidates the loop by inserting 47 ohms (75 ohms for XGC option) in the ground-check loop and a trip should occur in less than 250 ms.

The ground-check circuit is usually operated in the non-latching mode; however, it can be operated in the latching mode by connecting terminals 14 and 15.

The ground-check circuit is protected by a 1.5-A time-delay fuse (F1).

If the SE-134C is used in a ground-fault-only application, an SE-TA6A must be connected to the ground-check and cable-ground terminals to validate the ground-check circuit. See Fig. 1.

The typical maximum distance of a trailing cable is 5.0 km (3.1 miles) for the standard model and up to 10 km (6.3 miles) for the XGC option. Several factors may limit the maximum distance of the cable, including the ground-check wire gauge, and induced ac current in the ground-check loop.

2.3 RESET

All ground-fault trips are latching and ground-check trips can be latching or non-latching. To reset ground-fault trips or latching ground-check trips, press the RESET button or connect the RESET terminals 9 and 10. See Fig. 1.

Cycling the supply voltage will also reset ground-fault trips; however, if the ground-check circuit is configured for latching fail-safe operation, the ground-check circuit will trip when supply voltage is applied.

The single-shot reset circuit responds only to a momentary closure; a jammed or shorted button will not maintain a reset signal. The front-panel RESET button is inoperative when remote-reset terminals 9 and 10 are connected. See Section 4.5.

2.4 TRIP RELAY

Isolated, normally open (Trip A, terminals 24 and 25) and normally closed (Trip B, terminals 22 and 23) contacts are provided for use in a contactor- or breaker-control circuit. With no connection between terminals 12 and 13, the SE-134C trip relay operates in the fail-safe mode. This mode is used with undervoltage devices where the trip relay energizes and its normally open contact closes if the ground-fault and ground-check circuits are not tripped. This mode is recommended because:

- Undervoltage devices release if supply voltage fails.
- Undervoltage ground-check circuits do not allow the power circuit and open cable couplers to be energized until the ground-check loop is verified.

The fail-safe mode of operation of the SE-134C trip relay can be used for shunt-trip circuits with a stored-energy trip source. In this case, the normally closed trip contact is used—the contact opens when the SE-134C is energized and the ground-fault and ground-check circuits are not tripped. Care must be taken to ensure safe and correct operation during power up and power down.

Connect terminals 12 and 13 for non-fail-safe trip relay operation with shunt-trip devices. In this mode, the normally open trip contact is used—the trip contact is closed when a ground-fault or ground-check trip occurs.

Shunt-trip circuits are not fail-safe and are not recommended because:

- Shunt-trip devices do not operate if supply voltage fails.
- Shunt-trip ground-check circuits allow the power circuit and open cable couplers to be energized for a short interval after supply voltage is applied.

CAUTION: The SE-134C is not a lock-out device. Follow lock-out procedures for maintenance.

3. INDICATION

3.1 GROUND FAULT

A red TRIP LED indicates a ground-fault trip and the remote-indication relay GF is energized when the ground-fault circuit is not tripped (fail-safe indication-contact operation). A green SENSOR LED indicates a current sensor is correctly connected. If the SE-CS10-series current sensor is disconnected or shorted, the green LED will go out and the ground-fault circuit will trip. If the sensor fault is intermittent, the ground-fault circuit will trip and the green LED will flash to indicate that the trip was initiated by a sensor fault.

3.2 POWER

The green POWER LED indicates that the internal power supply is on.

3.3 DIAGNOSTIC ERROR

The red DIAGNOSTIC ERROR LED indicates that an internal error caused the SE-134C to trip. Return the SE-134C to the factory if a reset does not clear the trip.

Induced ac current in the ground-check loop can cause the LED to flicker. This is a normal condition and does not indicate a diagnostic error; the ground-check monitoring circuit is not affected.

3.4 GROUND CHECK

A red TRIP LED indicates a ground-check trip. A green VALID LED indicates a valid ground-check loop and the remote-indication relay GC is energized when the ground-check loop is valid (fail-safe indication-contact operation). Two yellow LED's indicate the status of an invalid ground-check loop. OPEN indicates the loop resistance exceeds the trip resistance and SHORT indicates the ground-check conductor is shorted to the ground conductor. A flashing yellow LED indicates the corrected cause of a latched ground-check trip.

4. INSTALLATION

4.1 GENERAL

This ground-fault ground-check monitoring system consists of an SE-134C Monitor, an SE-CS10-series Current Sensor, and an SE-TA6A-series Termination

Assembly connected as shown in Fig. 1. Select applications can use a combination of SE-TA12A and SE-TA12B Termination Assemblies (not compatible with the XGC option). See Technical Note GC-09. If required, remote indication and reset can be implemented with standard pilot devices, or with an RK-132 Remote-Indication-and-Reset Kit.

4.2 MONITOR

Each SE-134C is packaged with both panel- and surface-mounting hardware.

Outline and panel-cutout dimensions for the SE-134C are shown in Fig. 2. To panel mount the SE-134C, insert it through the panel cutout and secure it with the four supplied 8-32 locknuts and flat washers.

If an optional SE-IP65CVR-G is used, follow the included installation instructions. See Figs. 4 and 5.

All connections to the SE-134C are made through plug-in, wire-clamping terminal blocks for 24 to 12 AWG (0.2 to 2.5 mm²) conductors. Each plug-in terminal block can be secured to the monitor by two captive screws for reliable connections in high-vibration applications.

Outline dimensions and mounting details for surface mounting an SE-134C are shown in Fig. 3. Fasten the SE-134-SMA Surface-Mount Adapter to the mounting surface and make connections to the adapter terminal blocks. Follow the instructions in Fig. 3 to install or remove the SE-134C.

Use terminal 1 (L1) as the line terminal on ac systems or the positive terminal on dc systems. Use terminal 2 (L2/N) as the neutral terminal on ac systems or the negative terminal on dc systems.

NOTE: On revision 5 and newer units, terminal 3 (SPG) is internally connected to terminal 4. For these units an external terminal-3-to-terminal-4 connection is not required, nor is it necessary to remove the terminal-3 connection for dielectric-strength testing.

4.3 CURRENT SENSORS

Outline dimensions and mounting details for the SE-CS10-series current sensors are shown in Fig. 6. Pass only phase conductors through the sensor window as shown in Fig. 1. If a shield, ground, or ground-check conductor enters the sensor window, it must be returned through the window before it is terminated. Connect the current sensor to terminals 16 and 17. Ground terminal 17. Current-sensor primary and secondary connections are not polarity sensitive. See Section 4.7.

NOTE: SE-CS10-series current sensors are 600-V-rated current transformers. When system voltage is above 600 V, ensure conductors passed through the sensor window are insulated to system voltage.

4.4 TERMINATION ASSEMBLY

Outline dimensions and mounting details for the SE-TA6A, SE-TA6A-WL, and SE-TA6ASF-WL are shown in Figs. 7 and 8. Install the SE-TA6A at the load to complete the ground-check loop as shown in Fig. 1. Connect terminal G of the SE-TA6A to the equipment frame so that the ground-conductor-to-equipment-frame connection will be included in the monitored loop.

4.5 REMOTE OPERATION

Remote indication contacts and a reset input are provided as shown in Fig. 1.

The optional RK-132 Remote Kit is shown in Fig. 9. Connect terminals of the green ground-check indicator to SE-134C terminals 26 and 27 and the red ground-fault indicator to terminals 19 and 21. For remote reset, connect the normally open push-button switch across terminals 9 and 10.

4.6 PARALLEL-PATH ISOLATION

A PPI-600V can be used for parallel-path rejection. A PPI-600V will also eliminate inter-machine arcing and prevent stray ac and dc currents from flowing in the monitored ground wire. See Figs. 10 and 11. See Technical Note GC-10 “Parallel Path Isolator” at www.littelfuse.com/relayscontrols, or contact Littelfuse Startco for application details.

4.7 FERRITE PLACEMENT

A ferrite kit is included with CE-compliant options only. Where CE compliance is desired, install each ferrite as shown in Fig. 12. If a current sensor is used, connect the shield wire as shown in Fig. 13.

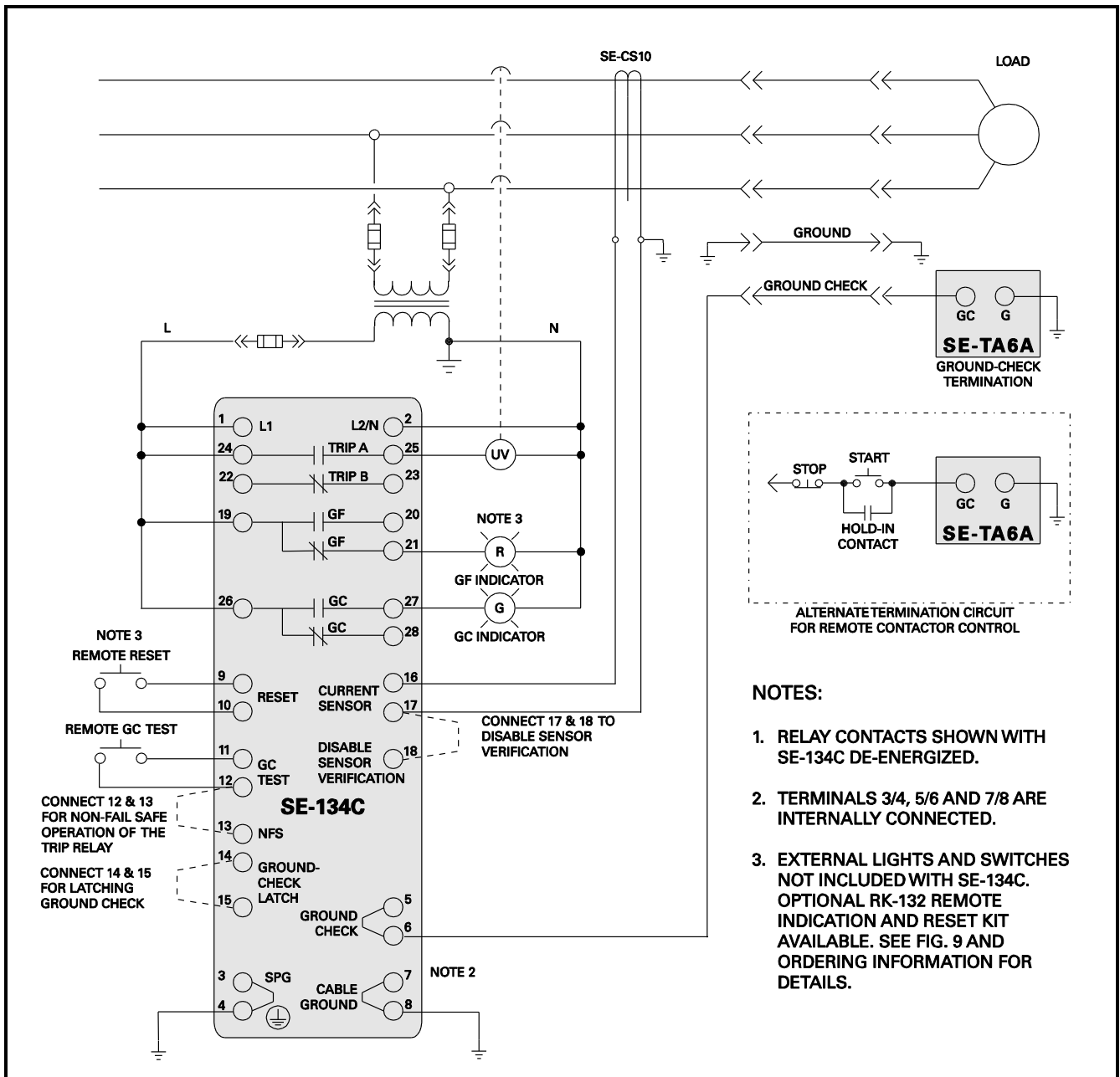

FIGURE 1. SE-134C Typical Application.

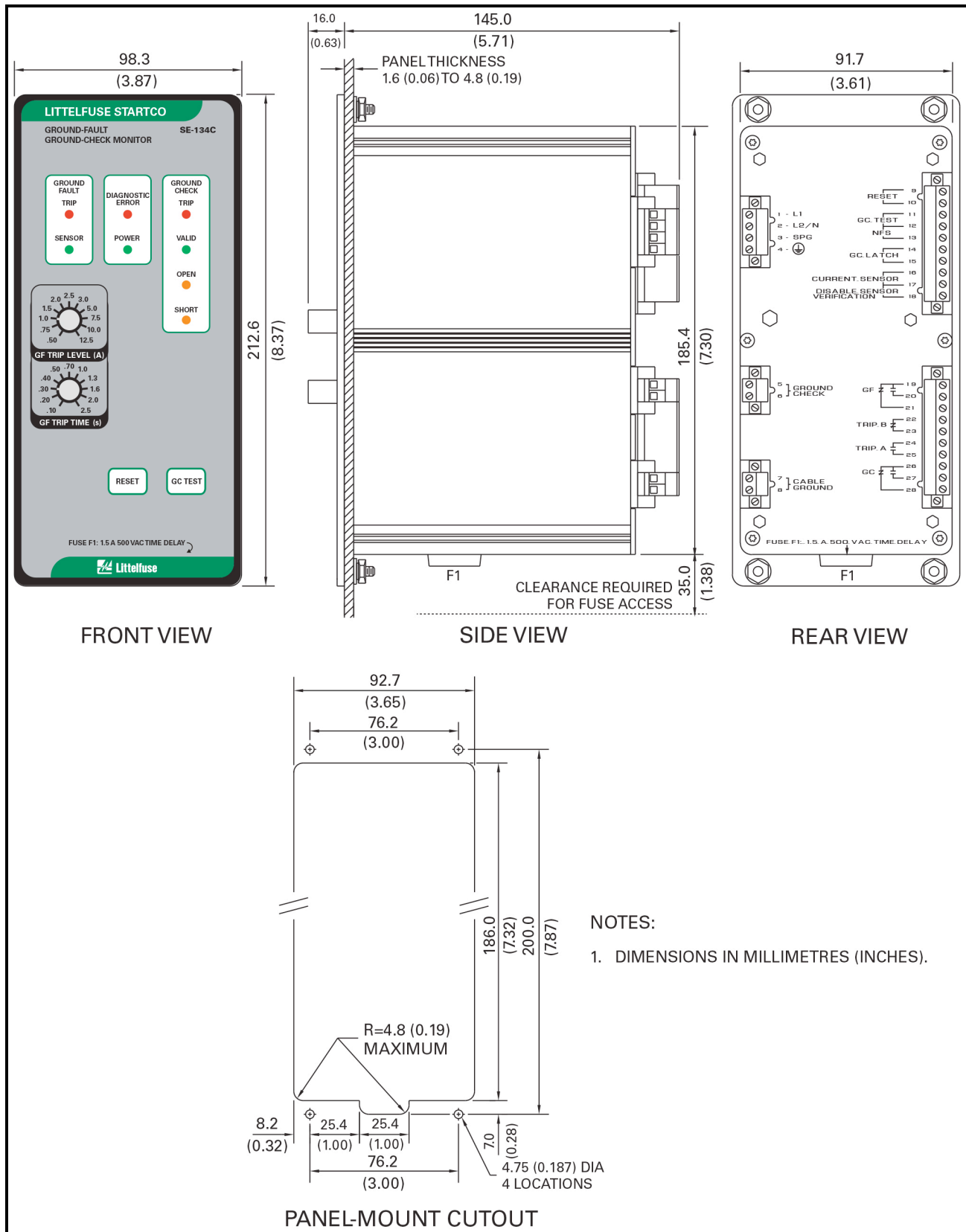

FIGURE 2. SE-134C Outline and Panel-Mounting Details.

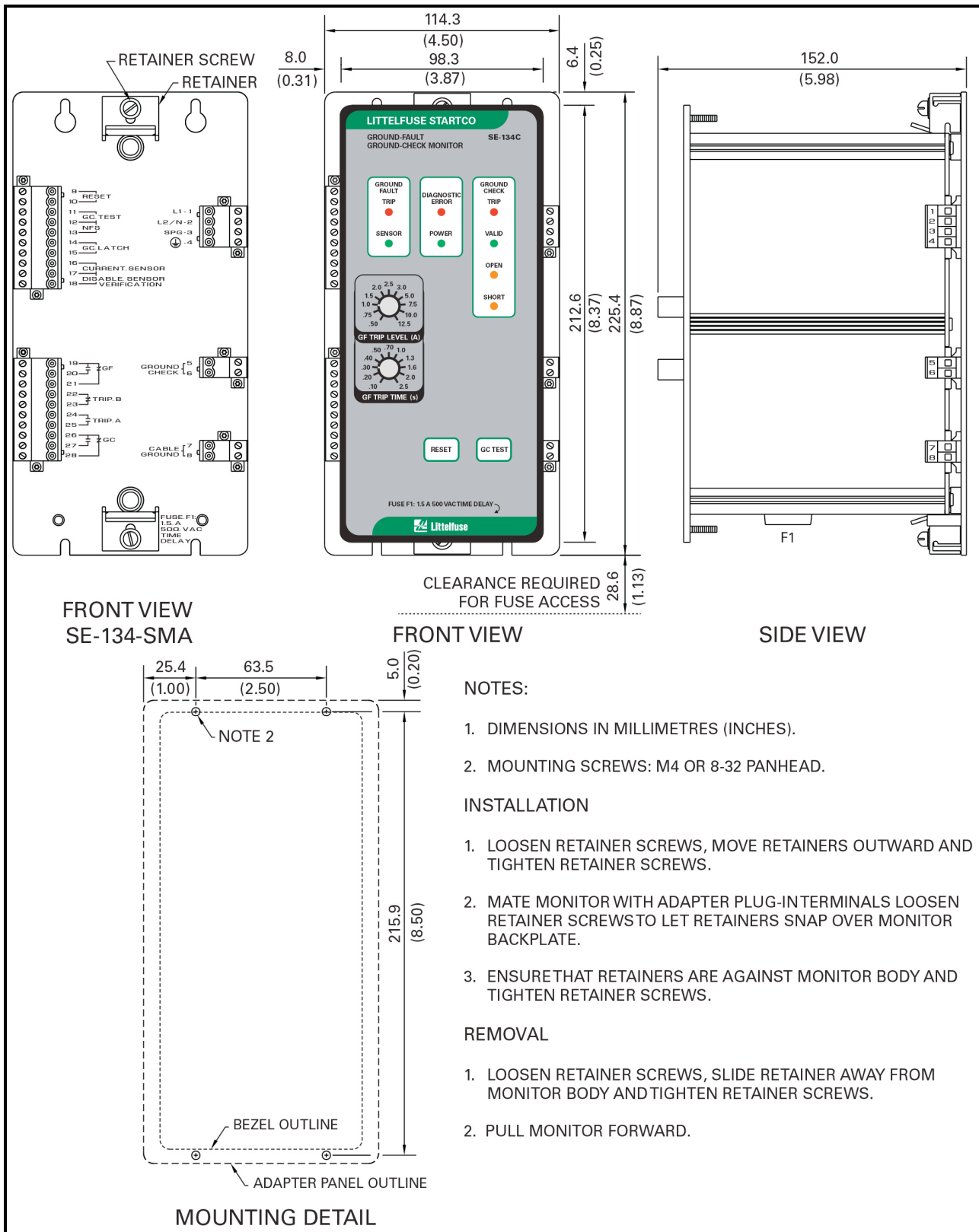

FIGURE 3. SE-134-SMA Surface Mount Adapter and SE-134C Surface-Mounting Details.

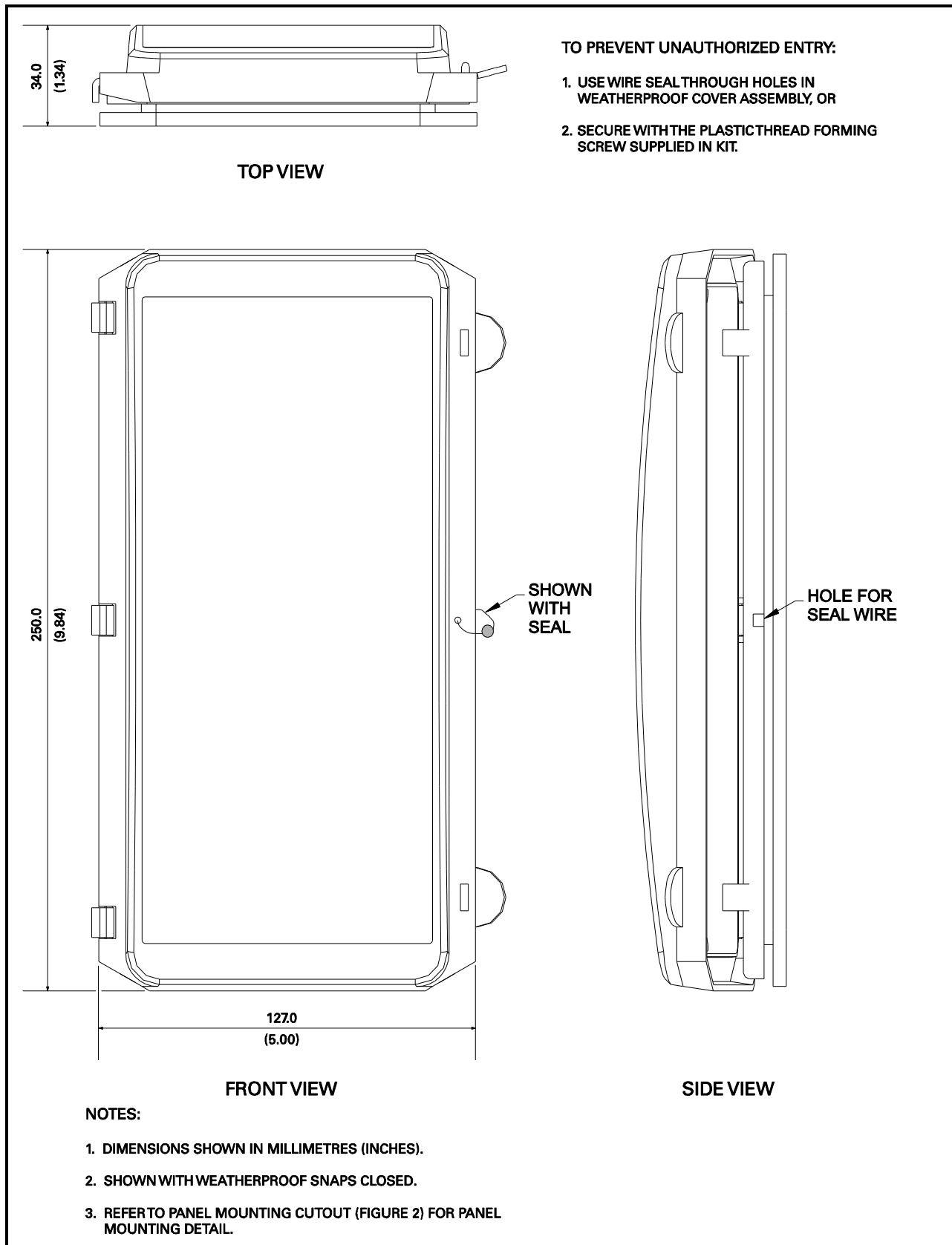

FIGURE 4. SE-IP65CVR-G Weatherproof Cover Outline.

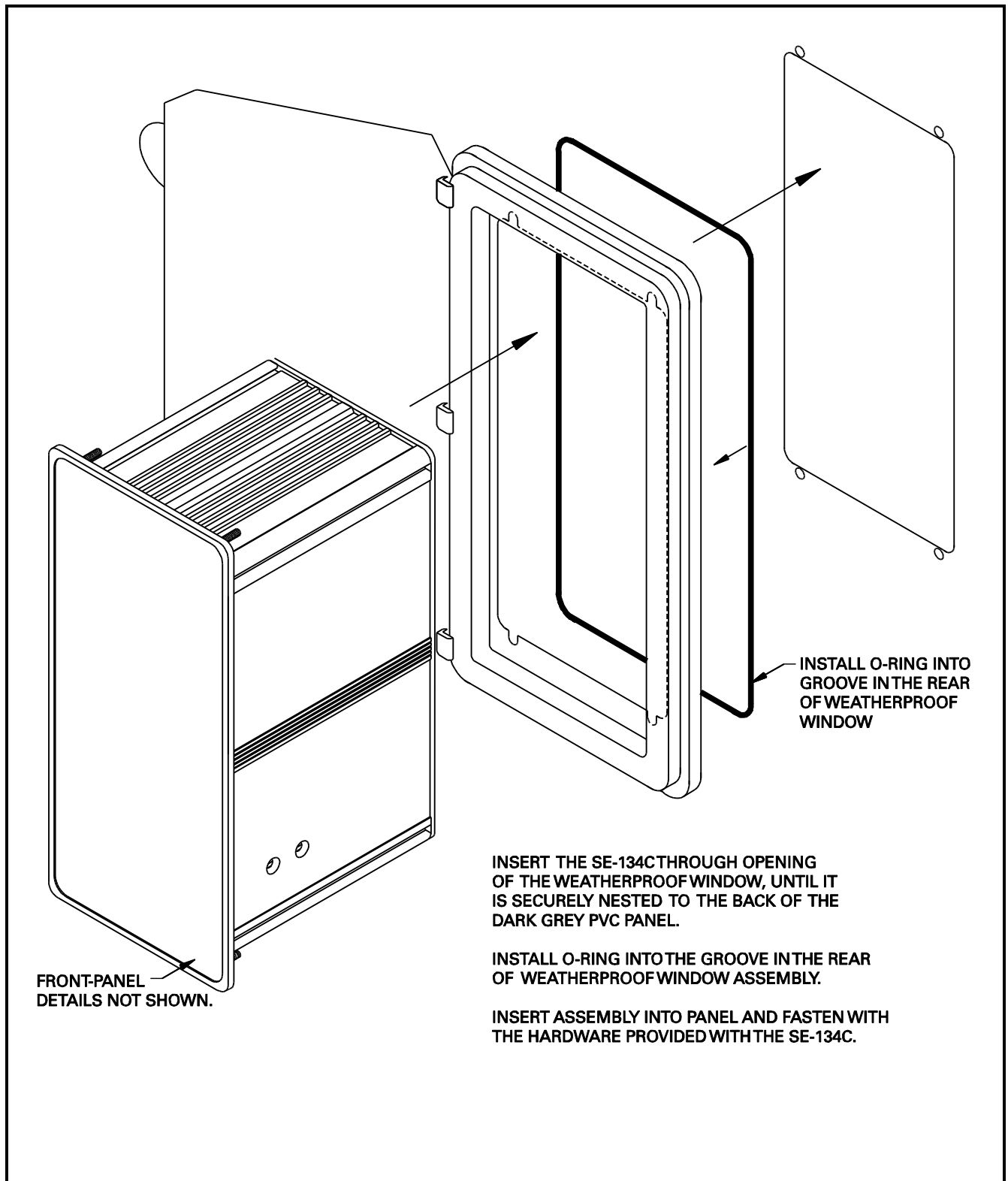

FIGURE 5. SE-IP65CVR-G Weatherproof Cover Installation.

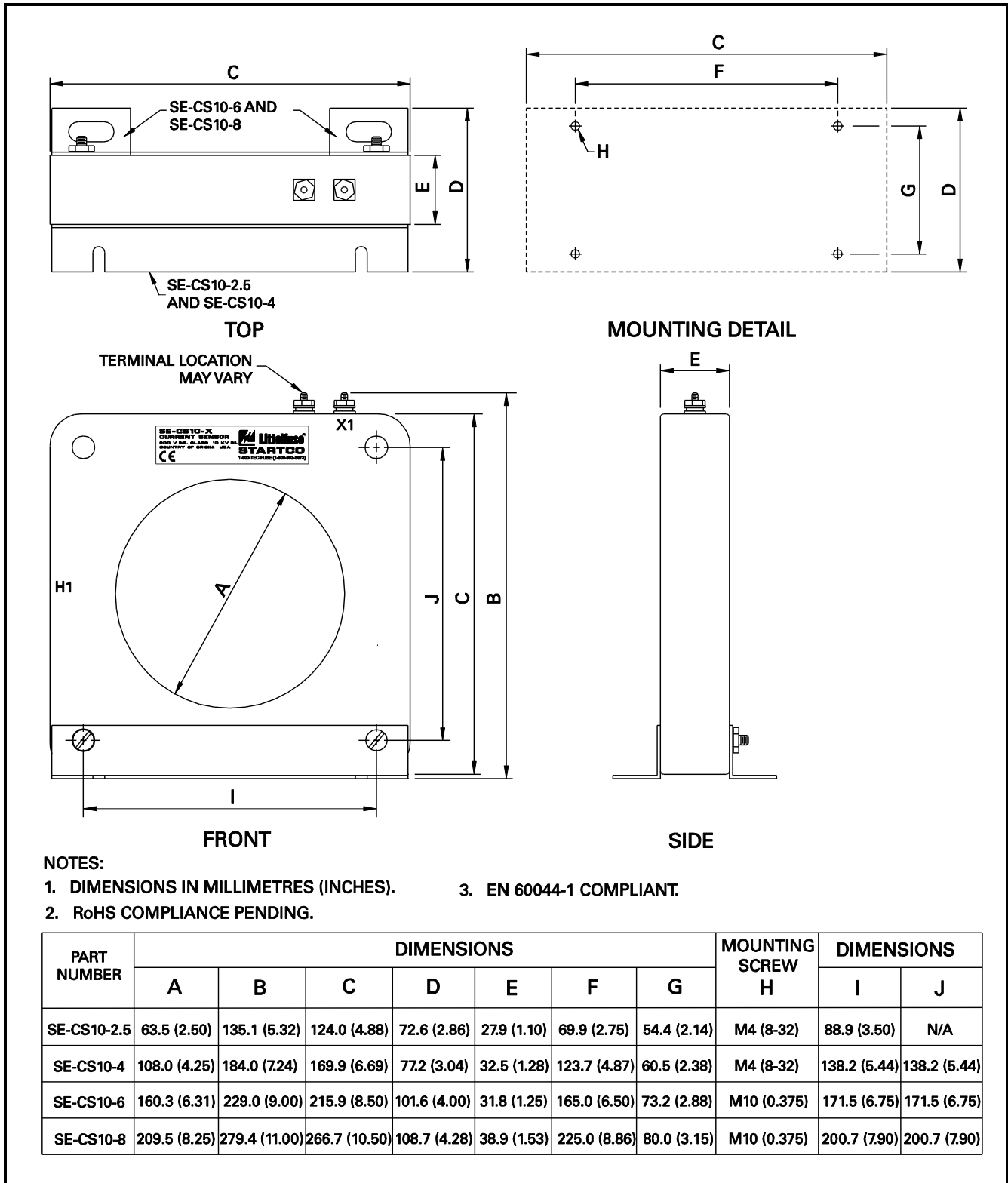

FIGURE 6. SE-CS10 Current Sensors.

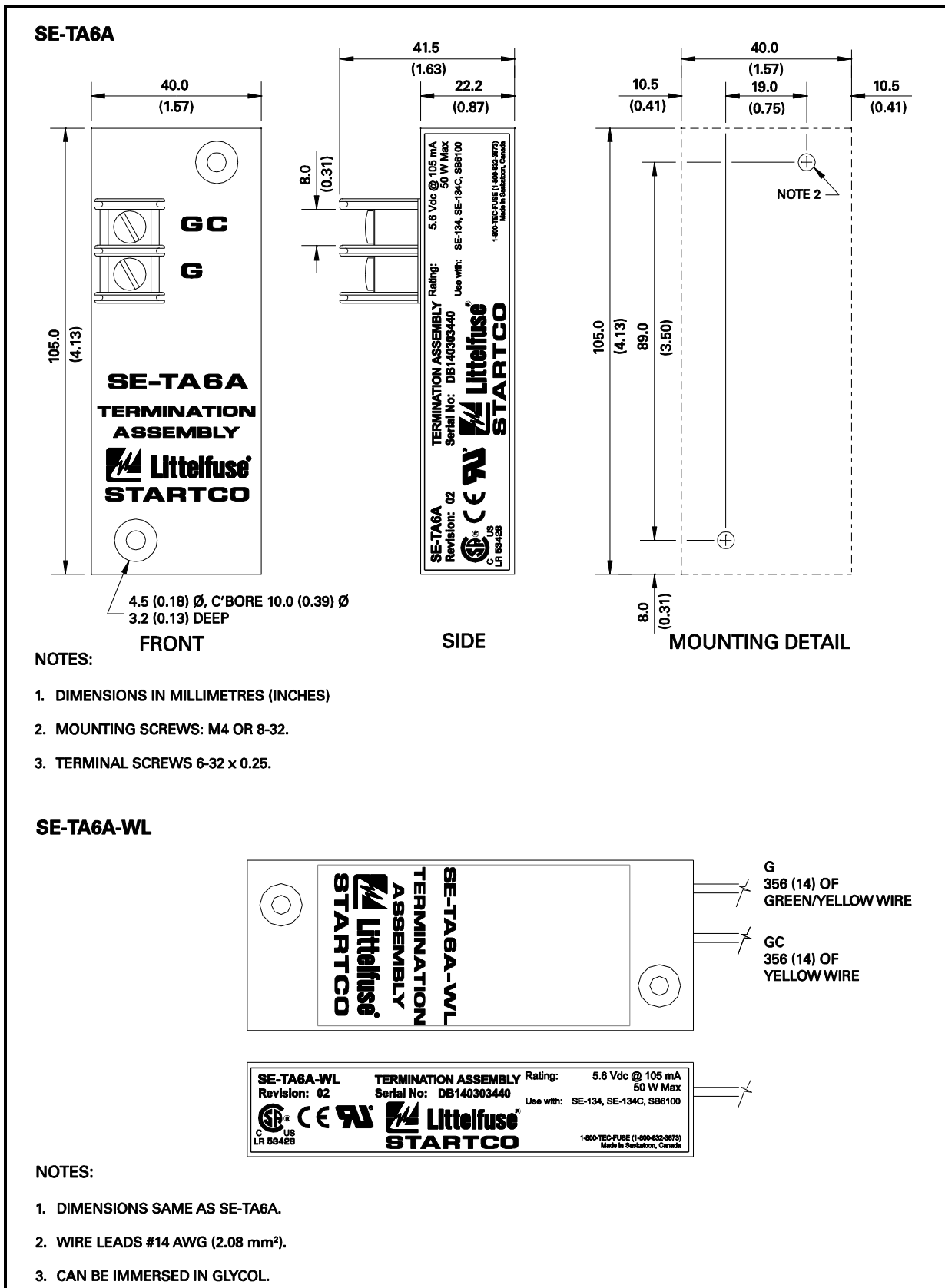

FIGURE 7. SE-TA6A and SE-TA6A-WL Termination Assemblies.

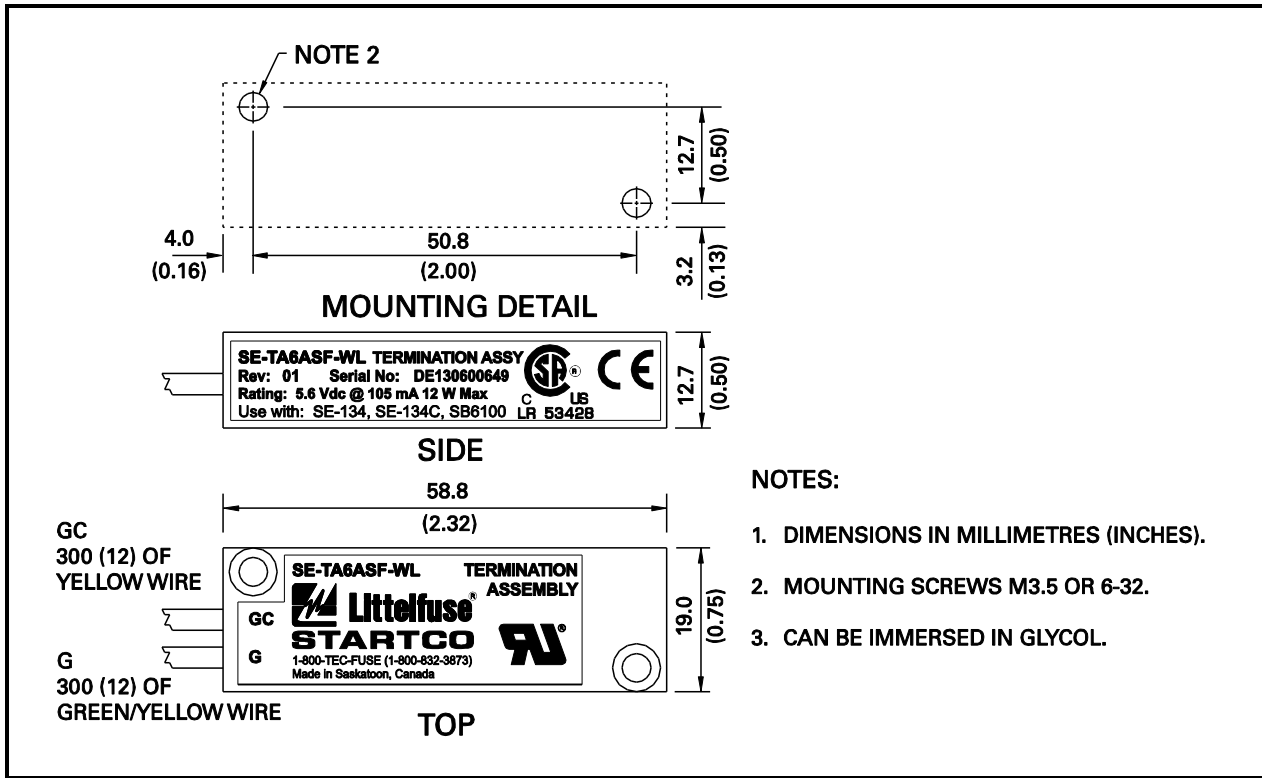

FIGURE 8. SE-TA6ASF-WL Small-Format-Wire-Lead Termination Assembly.

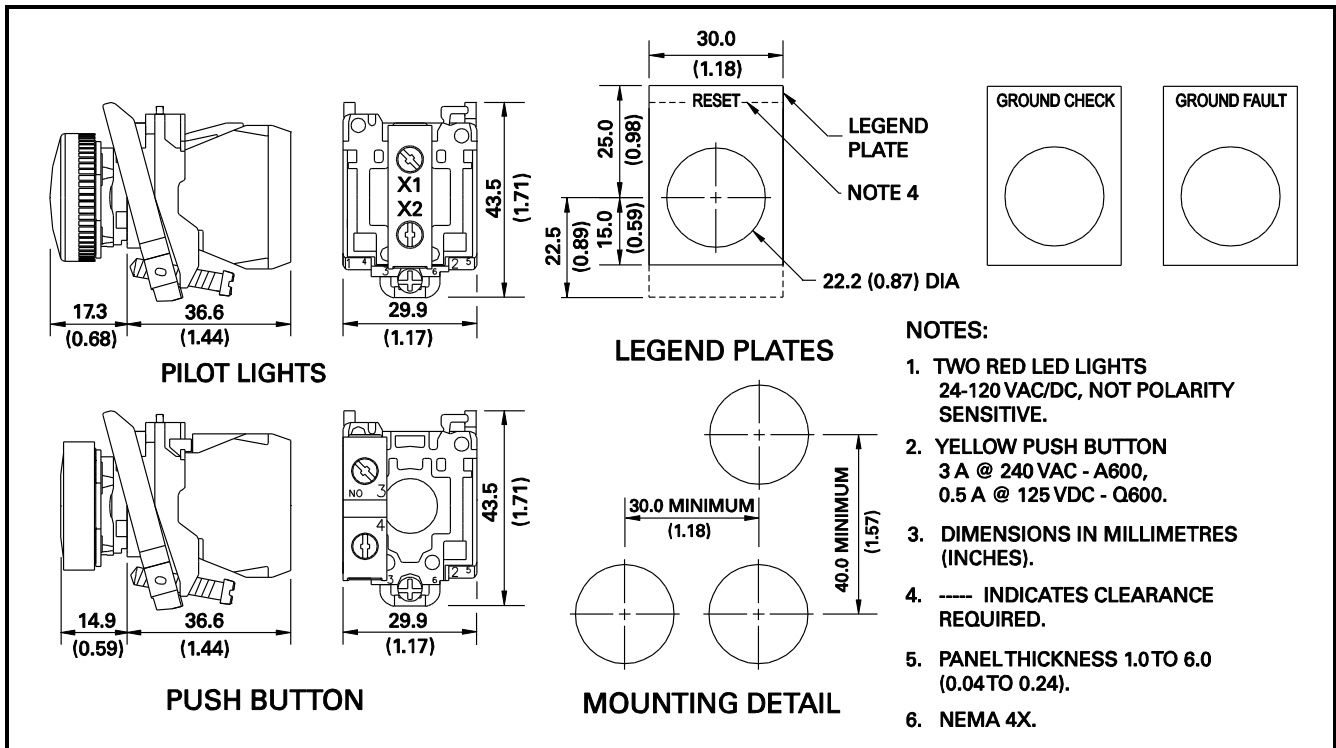

FIGURE 9. RK-132 Remote Indication and Reset Kit.

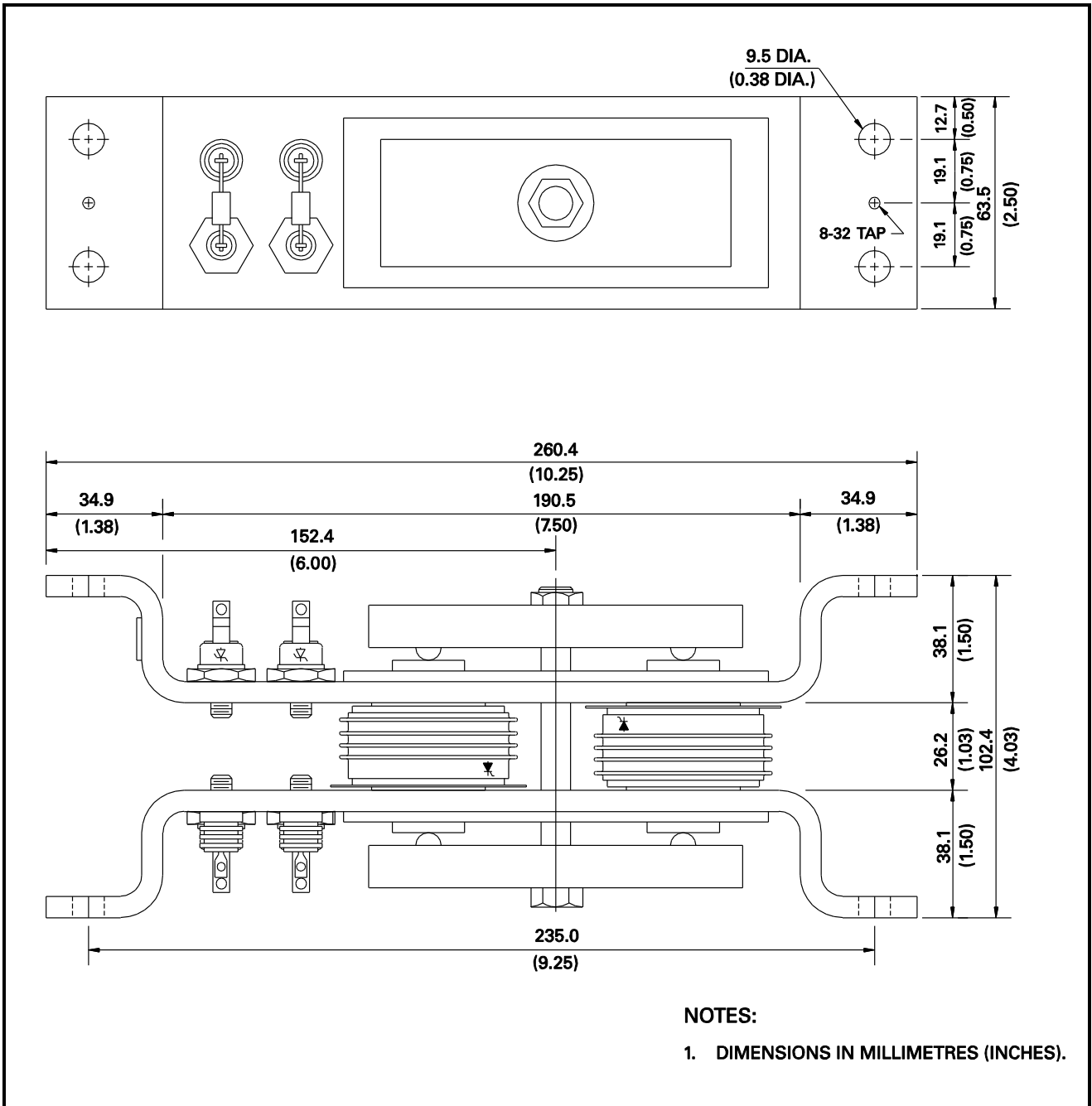

FIGURE 10. PPI-600V Parallel-Path Isolator.

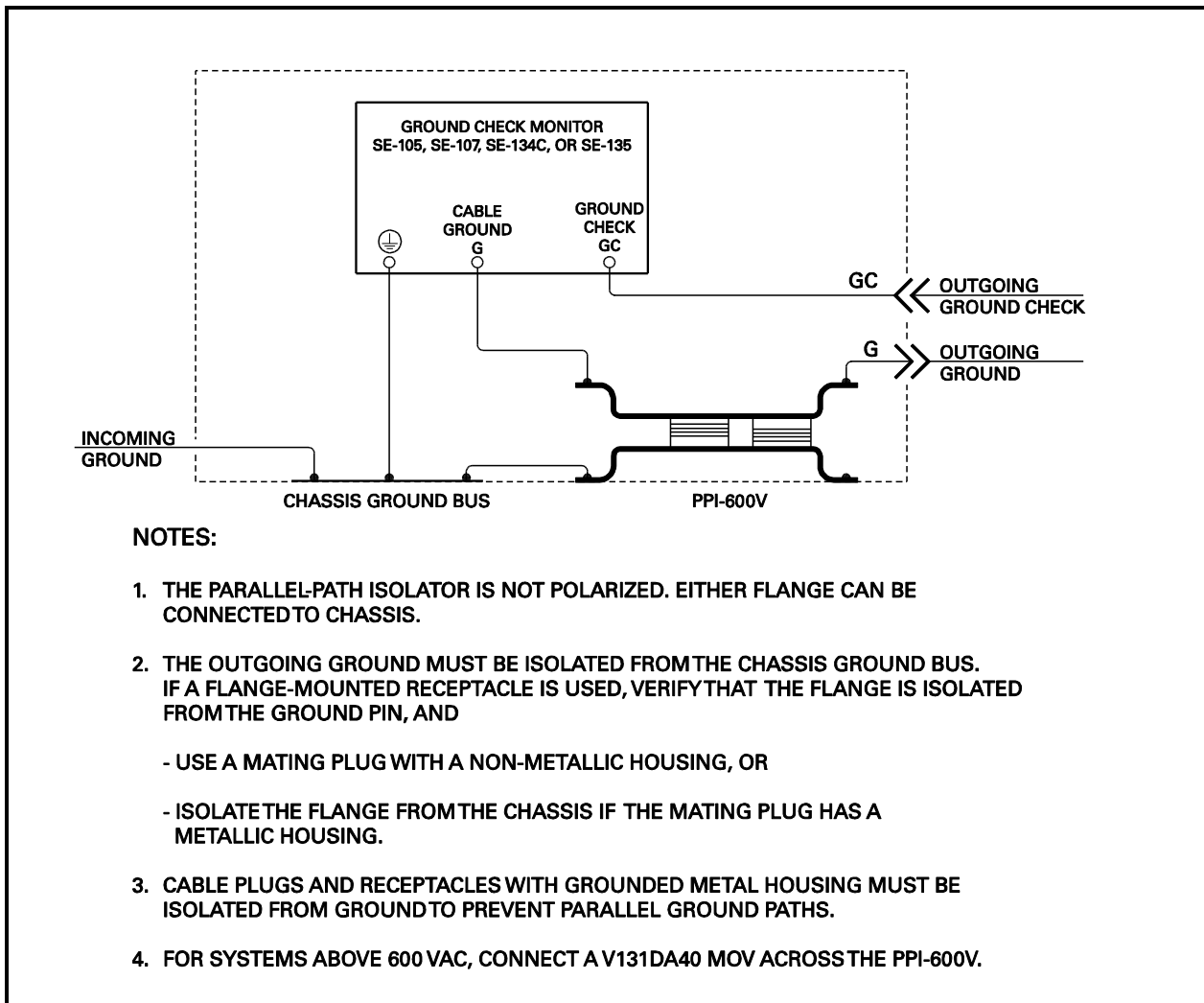
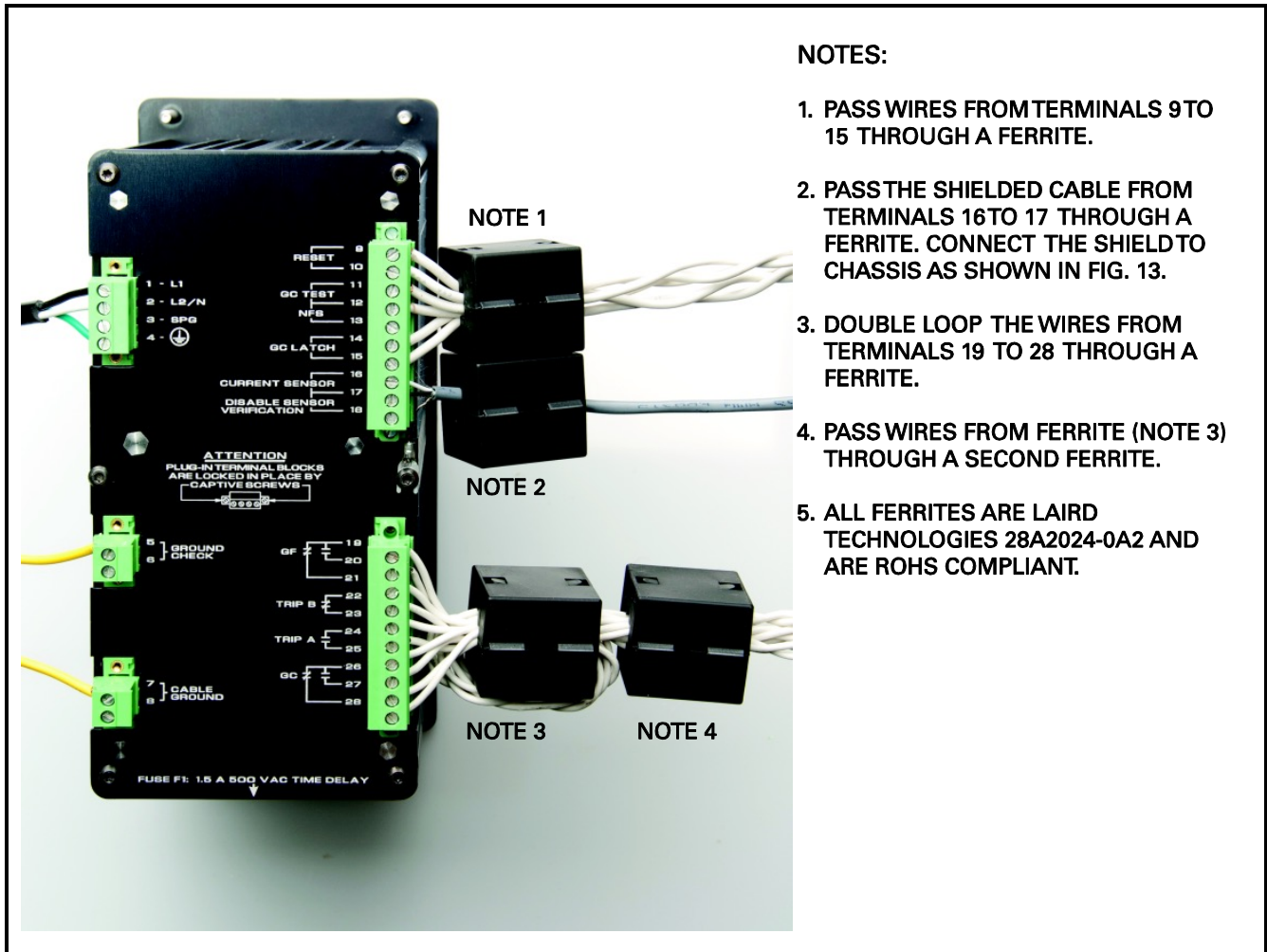

FIGURE 11. PPI-600V Typical Installation.



- NOTES:**
1. PASS WIRES FROM TERMINALS 9 TO 15 THROUGH A FERRITE.
 2. PASS THE SHIELDED CABLE FROM TERMINALS 16 TO 17 THROUGH A FERRITE. CONNECT THE SHIELD TO CHASSIS AS SHOWN IN FIG. 13.
 3. DOUBLE LOOP THE WIRES FROM TERMINALS 19 TO 28 THROUGH A FERRITE.
 4. PASS WIRES FROM FERRITE (NOTE 3) THROUGH A SECOND FERRITE.
 5. ALL FERRITES ARE LAIRD TECHNOLOGIES 28A2024-0A2 AND ARE ROHS COMPLIANT.

FIGURE 12. SE-134C with Ferrites Installed.

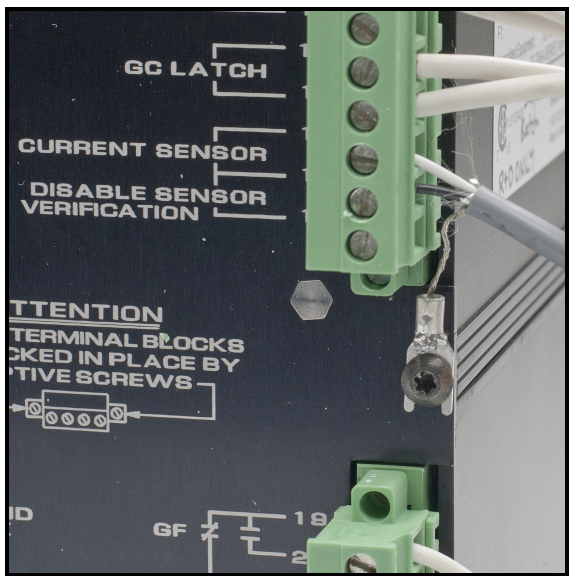

FIGURE 13. Current Sensor Shield Connection.

5. TECHNICAL SPECIFICATIONS

5.1 SE-134C

Supply:

Option 0.....	25 VA, 120-240 Vac (+10, -45%), 50-400 Hz; 15 W, 110-250 Vdc (+10, -25%)
Option 1	15 W, 24-48 Vdc (+50, -25%); 20 VA, 48 Vac (+10, -55%), 50-100 Hz

Ground-Fault Circuit:

Digital Filter	50 to 60 Hz, Bandpass
3 dB Frequency Response...	30 to 90 Hz
Trip-Level Settings5, .75, 1.0, 1.5, 2.0, 2.5, 3.0, 5.0, 7.5, 10.0, and 12.5 A
Trip-Time Settings10, .20, .30, .40, .50, .70, 1.0, 1.3, 1.6, 2.0, and 2.5 s
Thermal Withstand.....	150 A Continuous 1,000 A for 2.5 s (Ground-Fault Current)
Sensor Lead Resistance.....	2 Ω maximum
Trip-Level Accuracy	5% or 0.1 A
Trip-Time Accuracy	+50, -15 ms
Sensor Verification	Enabled or Disabled
Sensor-Fault Detection.....	Open and Short
Trip Mode	Latching

Ground-Check Circuit:

Open-Circuit Voltage	24 Vdc
Output Impedance	136 Ω
Loop Current	105 mA
Induced-ac Withstand	60 Vac Continuous, 120 Vac for 10 s, 250 Vac for 0.25 s
Pull-in Time	≤ 750 ms
Trip Resistance:	
Standard.....	28 Ω ± 10%
XGC Option	45 Ω ± 10%
Trip Time:	
Standard at 50 Ω.....	220 ± 30 ms
XGC Option at 75 Ω	220 ± 30 ms
Short Detection	Yes
Isolation.....	3 kV, 60 Hz, 1 s
Test.....	Front-Panel Button and Remote, N.O. Contact
Fuse Rating (F1)	1.5 A, 500 Vac, Time Delay
Fuse Part Number	FNQ 1½ Buss Fusetron
Trip Mode	Latching or Non-Latching

Trip Relay:

CSA/UL Contact Rating	8 A Resistive 250 Vac, 5 A 30 Vdc, 0.25 HP, B300 Pilot Duty
-----------------------------	---

Supplemental Contact Ratings:

Make/Carry (0.2 s)	30 A
Break dc	75 W Resistive, 35 W Inductive (L/R < 0.04)
Break ac.....	2,000 VA Resistive, 1,500 VA Inductive (PF > 0.4)
Subject to maximums of 8 A and 250 V (ac or dc)	
Contact Configuration.....	Isolated N.O. and N.C. Contacts
Operating Mode	Fail-Safe or Non-Fail-Safe
Maximum Switching Capacity	Fig.14

Remote-Indication Relays:

CSA/UL Contact Rating	8 A Resistive 250 Vac, 8 A 30 Vdc
-----------------------------	--------------------------------------

Supplemental Contact Ratings:

Make/Carry (0.2 s)	20 A
Break dc	50 W Resistive, 25 W Inductive (L/R < 0.04)
Break ac.....	2,000 VA Resistive, 1,500 VA Inductive (PF > 0.4)
Subject to maximums of 8 A and 250 V (ac or dc)	
Contact Configuration.....	N.O and N.C. (Form C)
Operating Mode	Fail-Safe
Maximum Switching Capacity	Fig.15

Trip Reset	Front-Panel Button and Remote, N.O. Contact
------------------	--

Terminal Block Rating	10 A, 300 Vac, 12 AWG (2.5 mm ²)
-----------------------------	---

PWB Conformal Coating	MIL-1-46058 qualified, UL QMJU2 recognized
-----------------------------	---

Mounting Configuration	Panel Mount and Surface Mount
------------------------------	----------------------------------

Dimensions:

Height	213 mm (8.4")
Width	99 mm (3.9")
Depth.....	132 mm (5.2")

Shipping Weight	2.3 kg (5.1 lb)
-----------------------	-----------------

Environment:

Operating Temperature.....	-40 to 60°C (-40 to 140°F)
Storage Temperature.....	-55 to 80°C (-67 to 176°F)
Humidity	85% Non-Condensing
IP Rating	IP40 when panel- mounted, IP20 otherwise

Surge Withstand	ANSI/IEEE 37.90.1-2002 (Oscillatory and Fast Transient)
-----------------------	--

EMC Tests:

Verification tested in accordance with EN 60255-26:2009.

Radiated and Conducted

Emissions CISPR 22:2008-09
Class A

Current Harmonics and

Voltage Fluctuations IEC 61000-3-2
and IEC 61000-3-3
Class A

Electrostatic Discharge IEC 61000-4-2
± 6 kV contact discharge
(direct and indirect)
± 8 kV air discharge

Radiated RF Immunity IEC 61000-4-3
10 V/m, 80-1,000 MHz,
80% AM (1 kHz)
10 V/m, 1.0 to 2.7 GHz,
80% AM (1 kHz)

Fast Transient IEC 61000-4-4
Class A: ± 4 kV (on AC
mains and I/O lines)

Surge Immunity IEC 61000-4-5
Zone B
± 1 kV differential mode
± 2 kV common mode

Conducted RF Immunity IEC 61000-4-6
10 V, 0.15-80 MHz,
80% AM (1 kHz)

Magnetic Field

Immunity IEC 61000-4-8
50 Hz and 60 Hz
30 A/m and 300 A/m

Power Frequency IEC 60255-22-7
Zone A: differential mode
150 Vrms
Zone A: common mode
300 Vrms

1 MHz Burst IEC 61000-4-18
± 1 kV differential mode
(line-to-line)
± 2.5 kV common mode

Certification.....CSA, Canada and USA



UL Listed



Australia



CE, European Union



FCC



To: CSA C22.2 No. 14 Industrial Control Equipment
UL 508 Industrial Control Equipment
UL 1053 Ground Fault Sensing and Relaying
Equipment
Australia, Regulatory Compliance Mark (RCM)
CE Low Voltage Directive
IEC 61010-1:2010 (3rd Edition)
FCC CFR47, Part 15, Subpart B,
Class A – Unintentional Radiators

ComplianceRoHS Pending

5.2 CURRENT SENSORS

Environment:

Operating Temperature -40 to 60°C (-40 to 140°F)
Storage Temperature -55 to 80°C (-67 to 160°F)

SE-CS10-2.5:

Current Ratio 1,000:5 A
Insulation 600-V Class
Window Diameter 63 mm (2.5")
Shipping Weight 690 g (1.5 lb)

SE-CS10-4:

Current Ratio 1,000:5 A
Insulation 600-V Class
Window Diameter 108 mm (4.2")
Shipping Weight 1.9 kg (4.3 lb)

SE-CS10-6:

Current Ratio 1,000:5 A
Insulation 600-V Class
Window Diameter 160 mm (6.3")
Shipping Weight 2.2 kg (4.8 lb)

SE-CS10-8:

Current Ratio 1,000:5 A
Insulation 600-V Class
Window Diameter 209 mm (8.2")
Shipping Weight 2.2 kg (4.8 lb)

Certification CE⁽¹⁾, European Union
CE
Compliance IEC 60044-1
RoHS Pending

Power Rating 12 W
Wire Leads 18 AWG (0.82 mm²),
300 mm (11.8")
Dimensions 58.8 x 19 x 12.7 mm
(2.32 x 0.75 x 0.5")
Shipping Weight 45 g (0.1 lb)

NOTES:

⁽¹⁾ When connected to an SE-134C.

5.3 TERMINATION ASSEMBLIES

SE-TA6A:

Characteristic 6-V Zener, Temperature
Compensated
Circuit Type High-Current Shunt
Regulator
Reverse Voltage 5.6 ±0.03 Vdc @ 100 mA
Forward Voltage 0.5 ±0.1 Vdc @ 100 mA
Operating Temperature -40 to 60°C (-40 to 140°F)
Current Range 2 mA to 25 A
Maximum Clamping
Voltage 55 V @ 250 A,
5x20 μs Pulse
Power Rating 50 W
Screw Terminal 6-32 x 0.25
Dimensions 105 x 40 x 41.5 mm
(4.13 x 1.57 x 1.63")
Shipping Weight 300 g (0.7 lb)

SE-TA6A-WL:

Characteristic 6-V Zener, Temperature
Compensated
Circuit Type High-Current Shunt Regulator
Reverse Voltage 5.6 ±0.03 Vdc @ 100 mA
Forward Voltage 0.5 ±0.1 Vdc @ 100 mA
Operating Temperature -40 to 60°C (-40 to 140°F)
Current Range 2 mA to 25 A
Maximum Clamping
Voltage 55 V @ 250 A,
5x20 μs Pulse
Power Rating 50 W
Wire Leads 14 AWG (2.08 mm²),
356 mm (14")
Dimensions 105 x 40 x 22.2 mm
(4.13 x 1.57 x 0.87")
Shipping Weight 300 g (0.7 lb)

SE-TA6ASF-WL:

Characteristic 6-V Zener, Temperature
Compensated
Circuit Type High-Current Shunt
Regulator
Reverse Voltage 5.6 ±0.03 Vdc @ 100 mA
Forward Voltage 0.5 ±0.1 Vdc @ 100 mA
Operating Temperature -40 to 60°C (-40 to 140°F)
Current Range 2 mA to 15 A
Maximum Clamping
Voltage 55 V @ 250 A,
5x20 μs Pulse

Certification CSA, Canada and USA



NOTES:

⁽¹⁾ When connected to an SE-134C.

6. ORDERING INFORMATION⁽¹⁾

SE-134C-□□□-□0

Future Options
Power Supply:
0 Universal ac/dc Supply
1 24- to 48-Vdc Supply⁽²⁾
Ground Check Options:
Blank Standard
XGC Extended-GC-Trip Resistance

⁽¹⁾ All options include CE/RCM unless otherwise stated.
CE/RCM models include a ferrite kit.

⁽²⁾ CE/RCM not available.

Ground-Check Termination:

SE-TA6A 50-W Termination
Assembly with Screw
Terminals
SE-TA6A-WL 50-W Termination
Assembly with Wire
Leads
SE-TA6ASF-WL 12-W Small-Format
Termination Assembly
with Wire Leads

Current Sensors:

SE-CS10-2.5 Current Sensor,
63 mm (2.5") window
SE-CS10-4 Current Sensor,
108 mm (4.2") window
SE-CS10-6 Current Sensor,
160 mm (6.3") window
SE-CS10-8 Current Sensor,
209 mm (8.2") window

Parallel Path Isolator:

PPI-600V For system voltages up to
600 Vac

Accessories:

RK-132.....	Remote Indication and Reset Kit, includes two 24-120-V pilot lights, a reset push button, and legend plates
SE-IP65CVR-G.....	Hinged transparent cover, IP65
SE-134-SMA.....	Surface-Mount Adapter, included with SE-134C
SE-134-HDWR	Hardware Kit (excludes ferrites and SE-134-SMA), included with SE-134C

7. WARRANTY

The SE-134C Ground-Fault Ground-Check Monitor is warranted to be free from defects in material and workmanship for a period of five years from the date of purchase.

Littelfuse Startco will (at Littelfuse Startco’s option) repair, replace, or refund the original purchase price of an SE-134C that is determined by Littelfuse Startco to be defective if it is returned to the factory, freight prepaid, within the warranty period. This warranty does not apply to repairs required as a result of misuse, negligence, an accident, improper installation, tampering, or insufficient care. Littelfuse Startco does not warrant products repaired or modified by non-Littelfuse Startco personnel.

8. TEST PROCEDURES

8.1 GROUND-CHECK TRIP TESTS

8.1.1 LATCHING GROUND-CHECK TRIP TEST

Connect the monitor, current sensor and termination assembly as shown in Fig 16. Connect terminals 14 and 15 for latching operation. With supply voltage applied, the POWER, SENSOR, and VALID LED’s will be on.

Open the ground-check loop by removing either the GC or G connection between the monitor and the termination assembly (pressing the faceplate GC TEST button will also perform an open-ground-check test). The monitor will trip. The trip contacts (terminals 22-23 and 24-25) and the ground-check indication contacts (terminals 26-27 and 26-28) will change state. The VALID LED will be off, and both the GROUND CHECK TRIP and the OPEN LED’s will be on.

Reconnect the ground-check loop. The VALID and TRIP LED’s will be on and the OPEN LED will be flashing. The TRIP contacts (terminals 22-23 and 24-25) will remain latched and ground-check indication contacts (terminals 26-27 and 26-28) will change state.

Reset the monitor.

Short the ground-check loop by connecting G to GC. The monitor will trip. The trip contacts (terminals 22-23 and 24-25) and the ground-check indication contacts (terminals 26-27 and 26-28) will change state. The VALID LED will be off, and both the GROUND CHECK TRIP and the SHORT LED’s will be on.

Remove the short from G to GC. The VALID and TRIP LED’s will be on and the SHORT LED will be flashing. The TRIP contacts (terminals 22-23 and 24-25) will remain latched and ground-check indication contacts (terminals 26-27 and 26-28) will change state.

Reset the monitor.

8.1.2 NON-LATCHING GROUND-CHECK TRIP TEST

Connect the monitor, current sensor and termination device as shown in Fig. 16. With supply voltage applied, the POWER, SENSOR, and VALID LED’s will be on.

Open the ground-check loop by removing either the GC or G connection between the monitor and the termination assembly (pressing the faceplate GC Test button will also perform an open circuit test). The monitor will trip. The trip contacts (terminals 22-23 and 24-25) and the ground-check indication contacts (terminals 26-27 and 26-28) will change state. The VALID LED will be off, and both the GROUND CHECK TRIP and the OPEN LED’s will be on.

Reconnect the ground-check loop. The monitor will reset.

Short the ground-check loop by connecting G to GC. The monitor will trip. The trip contacts (terminals 22-23 and 24-25) and the ground-check indication contacts (terminals 26-27 and 26-28) will change state. The VALID LED will be off, and both the GROUND CHECK TRIP and the SHORT LED’s will be on.

Remove the short from G to GC. The monitor will reset.

8.2 TRIP RELAY FAIL-SAFE MODE TEST

Connect the monitor, current sensor and termination device as shown in Fig. 16. With supply voltage applied, the POWER, SENSOR, and VALID LED’s will be on. The output contacts between terminals 22 and 23 will be open and between 24 and 25 will be closed.

Remove the supply voltage. The output contacts between terminals 22 and 23 will close and the output contacts between terminals 24 and 25 will open.

8.3 CURRENT-SENSOR-VERIFICATION TEST

Connect the monitor, current sensor and termination device as shown in Fig. 16. With supply voltage applied, the POWER, SENSOR, and VALID LED’s will be on.

Open the current-sensor circuit by disconnecting one of the sensor leads. The monitor will trip. The trip contacts (terminals 22-23 and 24-25) and the ground-fault indication contacts (terminals 19-20 and 19-21) will change state. The GROUND FAULT TRIP LED will be on and the SENSOR LED will be off.

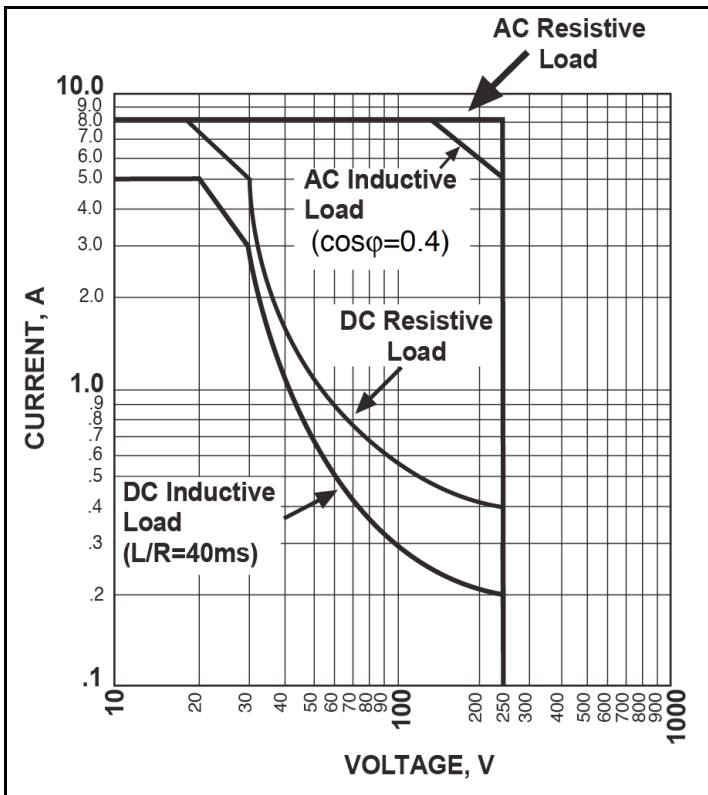

FIGURE 14. Trip Relay Maximum Switching Capacity.

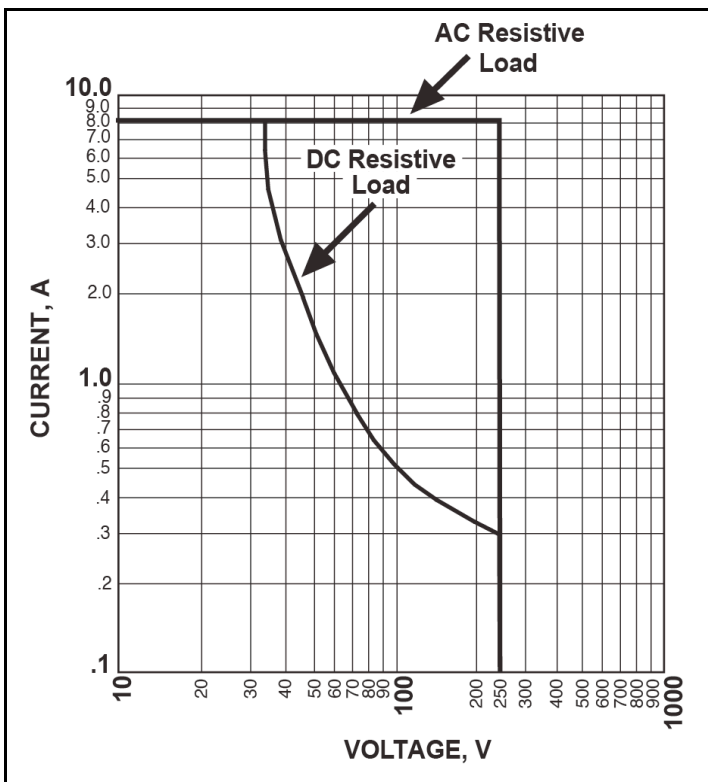

FIGURE 15. Remote-Indication Relays GC and GF Maximum Switching Capacity.

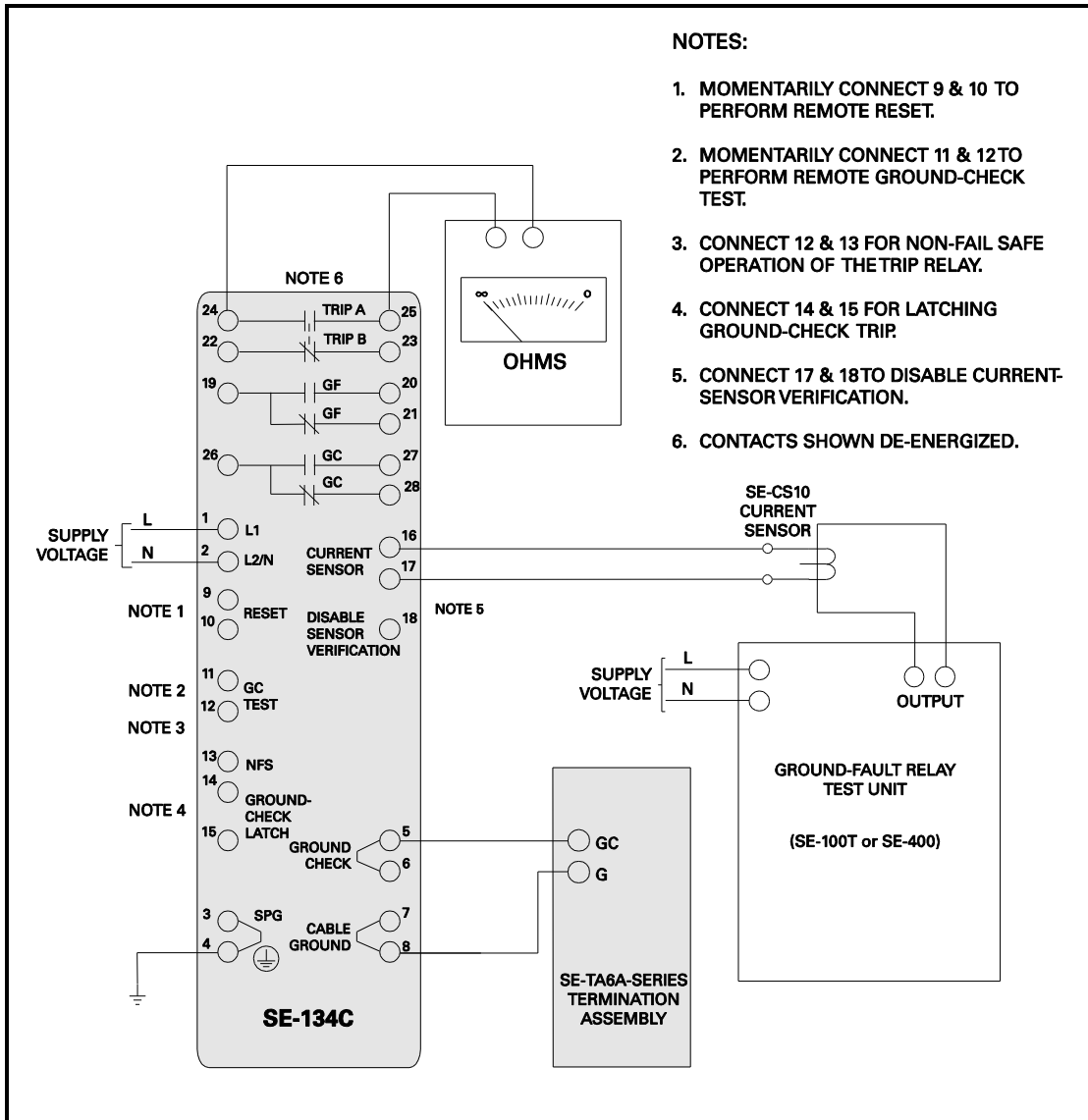

FIGURE 16. Ground-Fault-Test Circuit.

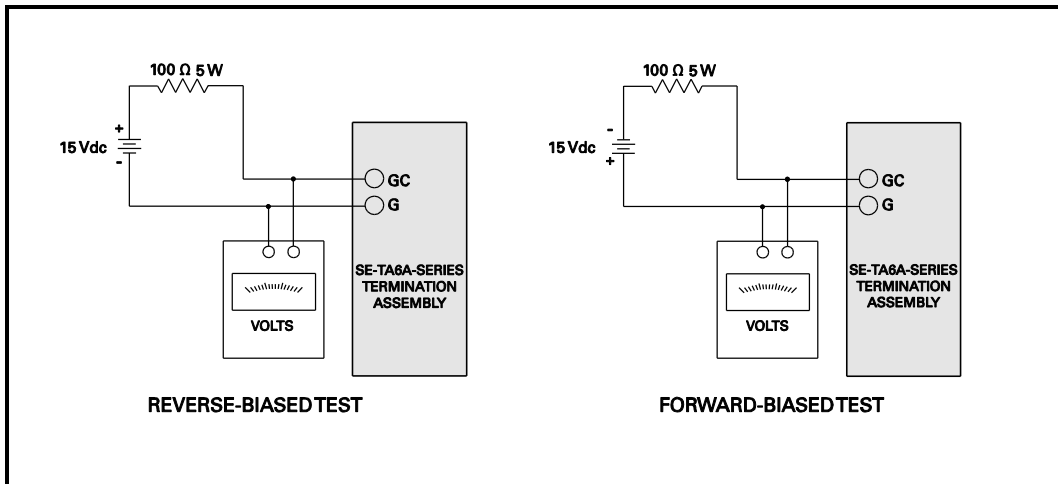

FIGURE 17. Termination-Assembly-Test Circuits.

**APPENDIX A
SE-134C REVISION HISTORY**

MANUAL RELEASE DATE	MANUAL REVISION	PRODUCT REVISION (REVISION NUMBER ON PRODUCT LABEL)
September 8, 2016	7-D-090816	05D
October 1, 2014	7-C-100114	
August 20, 2013	7-B-111213	
May 6, 2013	7-A-050613	

MANUAL REVISION HISTORY

REVISION 7-D-090816

SECTION 2

XGC compatibility notes added.

SECTION 5

Added Figs. 14 and 15.
RCM Certification added.

SECTION 6

RCM Certification added.

REVISION 7-C-100114

SECTION 4

Figs. 7, 8, and 11 updated.

REVISION 7-B-111213

SECTION 2

Maximum trailing cable length added.

SECTION 5

Additional termination assembly and compliance specifications added.

REVISION 7-A-050613

SECTION 4

Ferrite placement instructions added.

SECTION 5

CE specifications, XGC option, and dimensions added.

SECTION 6

Ordering information updated.

PRODUCT REVISION HISTORY

REVISION 05D

Ferrite kit added.

Компания «Life Electronics» занимается поставками электронных компонентов импортного и отечественного производства от производителей и со складов крупных дистрибьюторов Европы, Америки и Азии.

С конца 2013 года компания активно расширяет линейку поставок компонентов по направлению коаксиальный кабель, кварцевые генераторы и конденсаторы (керамические, пленочные, электролитические), за счёт заключения дистрибьюторских договоров

Мы предлагаем:

- Конкуренеспособные цены и скидки постоянным клиентам.
- Специальные условия для постоянных клиентов.
- Подбор аналогов.
- Поставку компонентов в любых объемах, удовлетворяющих вашим потребностям.
- Приемлемые сроки поставки, возможна ускоренная поставка.
- Доставку товара в любую точку России и стран СНГ.
- Комплексную поставку.
- Работу по проектам и поставку образцов.
- Формирование склада под заказчика.
- Сертификаты соответствия на поставляемую продукцию (по желанию клиента).
- Тестирование поставляемой продукции.
- Поставку компонентов, требующих военную и космическую приемку.
- Входной контроль качества.
- Наличие сертификата ISO.

В составе нашей компании организован Конструкторский отдел, призванный помогать разработчикам, и инженерам.

Конструкторский отдел помогает осуществить:

- Регистрацию проекта у производителя компонентов.
- Техническую поддержку проекта.
- Защиту от снятия компонента с производства.
- Оценку стоимости проекта по компонентам.
- Изготовление тестовой платы монтаж и пусконаладочные работы.



Тел: +7 (812) 336 43 04 (многоканальный)
Email: org@lifeelectronics.ru