

## FEATURES

- 0.65V to 2.5V Single-supply operation
- AC-coupled Non-inverting and Inverting configurations supplied
- Fully Assembled and Tested
- 2mm x 2mm 2-layer demo board

## COMPONENT LIST

DESIGNATION	QTY	DESCRIPTION
C1, C2, C3, C5	4	0.1 $\mu$ F $\pm$ 10% capacitors (0805)
C4, C6	2	1 $\mu$ F $\pm$ 10% capacitors (0805)
R2	1	665k $\Omega$ $\pm$ 1% resistor (0805)
R7	1	500k $\Omega$ $\pm$ 1% resistor (0805)
R5, R6, R10	3	1M $\Omega$ $\pm$ 1% resistors (0805)
R8, R9	2	1.25M $\Omega$ $\pm$ 1% resistors (0805)
R1, R3, R4	3	2M $\Omega$ $\pm$ 1% resistors (0805)
U1, U2	2	TS1001 operational amplifiers
TP1-TP11	10	Test points

## DESCRIPTION

The demo board for the TS1001 is a completely assembled and tested circuit board that can be used for evaluating the TS1001. The TS1001 is the first 0.8V/0.6 $\mu$ A, precision CMOS operational amplifier in the industry. The TS1001 exhibits an offset voltage of 0.5mV, a typical input bias current of 25pA, and a rail-to-rail input and output stages. The TS1001 can operate from single-supply voltages from 0.65V to 2.5V.

The TS1001 is fully specified at  $V_{DD} = 0.8V$  and over the industrial temperature range (-40 $^{\circ}$ C to +85 $^{\circ}$ C). It is available in a PCB-space saving 5-lead SC70 surface-mount package.

Product data sheets and additional documentation can be found on factory web site at [www.touchstonesemi.com](http://www.touchstonesemi.com).

## Ordering Information

Order Number	Description
TS1001DB	Demo Board

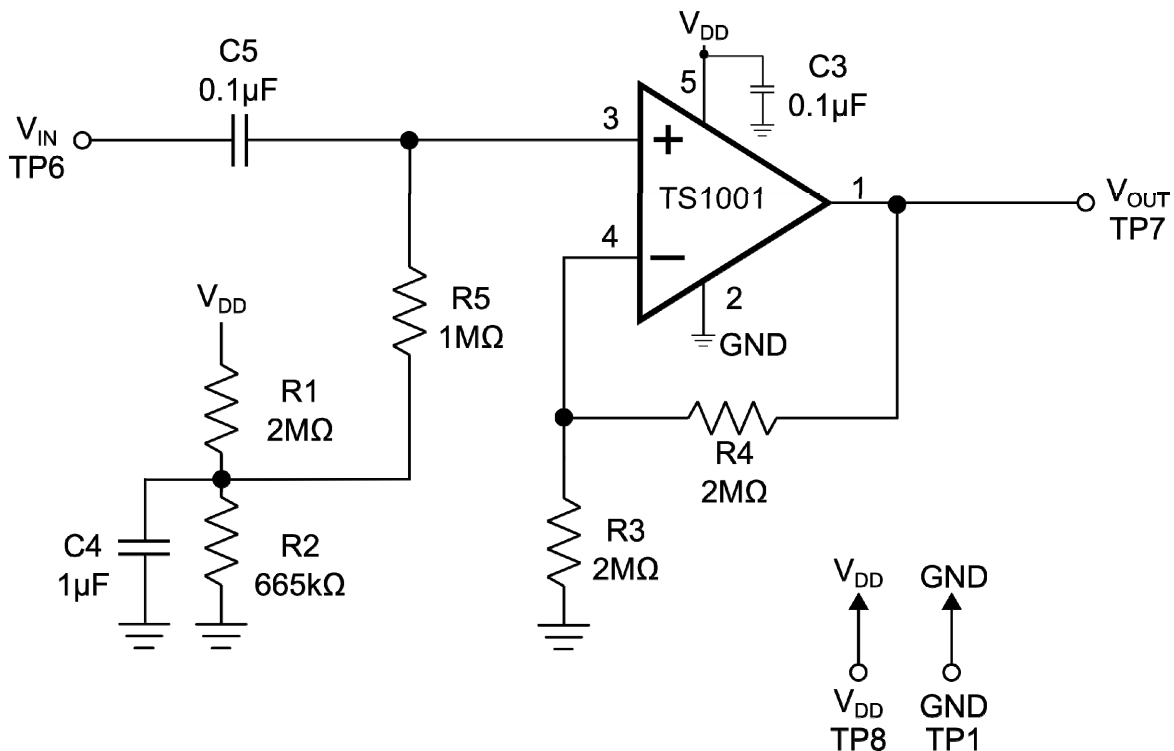

Figure 1. Non-Inverting Configuration

# TS1001 Op Amp Demo Board



## Description

The TS1001 demo board provides two configurations for evaluating the TS1001 operational amplifier in one single PCB board, namely a non-inverting configuration located on the left-hand side of the board and an inverting configuration located on the right-hand side of the board. In both cases, the input to each circuit is AC-coupled. The demo board provides a re-biasing scheme at one-half the power supply or  $V_{DD}/2$  for the inverting configuration and at  $V_{DD}/4$  for the non-inverting configuration.

The TS1001 demo board provides a dedicated power supply for the non-inverting circuit and a dedicated power supply for the inverting circuit. This provides the user the flexibility of evaluating one circuit at a time or both at the same time.

In both the non-inverting and the inverting configuration, the AC-coupling capacitor creates a high pass filter. The resulting cut-off frequency,  $f_c$ , is given as:

$$f_c = \frac{1}{2\pi RC}$$

In the non-inverting circuit,  $R=R5=1M\Omega$  and  $C=C5=0.1\mu F$ . In the inverting case,  $R=R10=1M\Omega$  and  $C=C1=0.1\mu F$ . In both cases, these component values generate a high-pass cut-off frequency of 1.6Hz.

## Default Configurations

### Non-Inverting configuration

In the non-inverting configuration, the circuit's transfer function is given by the following equation:

$$\frac{V_{OUT}}{V_{IN}} = 1 + \frac{R4}{R3}$$

With  $R4=2M\Omega$  and  $R3=2M\Omega$  the circuit signal gain is 2 with a circuit bandwidth of 2kHz. This results in an overall circuit bandwidth range of 1.6Hz to 2kHz.

### Inverting configuration

In an inverting configuration, the circuit's transfer function is given by the following equation:

$$\frac{V_{OUT}}{V_{IN}} = -\frac{R6}{R10}$$

In this case,  $R6=1M\Omega$  and  $R10=1M\Omega$ . This results in a signal gain of -1 with a circuit bandwidth of 2kHz and an overall circuit bandwidth range of 1.6Hz to 2kHz.

## Quick Start Procedures

### Required Equipment

- TS1001 demo board
- DC Power Supply, Single or Dual Output
- Function Generator
- 4-channel Oscilloscope
- Two  $1M\Omega$  oscilloscope probes

Signal	Non-Inverting Circuit	Inverting Circuit
$V_{DD}$	TP8	TP4
GND	TP1, TP10, TP11	TP5, TP9
$V_{IN}$	TP6	TP3
$V_{OUT}$	TP7	TP2

Table 1. Demo board test points

### Non-Inverting Configuration

In order to evaluate the TS1001 operational amplifier in the non-inverting configuration, the following steps are to be performed:

- 1) Before connecting the DC power supply to the demo board power test points, turn on the power supply and set the DC voltage to 2.5V and then turn it off.
- 2) Set the function generator frequency to 500Hz and output level with a  $V_{OH} = 1.35V$  and a  $V_{OL} = 1.15V$ . This sets the input signal swing to  $200mV_{PP}$ , centered at 1.25V.
- 3) In order to monitor the input and output signal, select two channels on the oscilloscope and set the vertical voltage scale and the vertical position on each channel to  $100mV/DIV$  and  $-1.25V$ , respectively. Set the horizontal time scale to  $500\mu s/DIV$ .
- 4) Connect the positive terminal of the DC power supply to TP8 and the ground terminal to TP1. For all other connections, please refer to Table 1.
- 5) Connect the signal output of the function generator to TP6 and the ground terminal to TP10.

- 6) To monitor the input, connect the signal terminal of one of the oscilloscope probes to TP6 and the ground terminal to TP10. To monitor the output, use the second probe to connect the signal terminal to TP7 and the ground terminal to TP11.
- 7) Turn on the power supply and check that the power supply current is approximately 1.8 $\mu$ A.
- 8) Turn on the function generator.
- 9) Observe the input and output signal. The output signal is an amplified version of the input signal with an output swing of approximately 400mV<sub>PP</sub>, corresponding to a signal gain of two.

## Inverting Configuration

In order to evaluate the TS1001 operational amplifier in the inverting configuration, the following steps are to be performed:

- 1) Before connecting the DC power supply to the demo board, turn on the power supply and set the DC voltage to 2.5V and then turn it off.
  - 2) Set the function generator output frequency to 500Hz and output level with a  $V_{OH} = 1.35V$  and a  $V_{OL} = 1.15V$ . This sets the input swing to 200mV<sub>PP</sub>, centered at 1.25V.
- 3) In order to monitor the input and output signal, select two channels on the oscilloscope and set the vertical voltage scale and the vertical position on each channel to 100mV/DIV and -1.25V, respectively. Set the horizontal time scale to 500 $\mu$ s/DIV.
  - 4) Connect the positive terminal of the DC power supply to TP4 and the ground terminal to TP5. For all other connections, please refer to Table 1.
  - 5) Connect the signal output of the function generator to TP3 and the ground terminal to TP9.
  - 6) To monitor the input, connect the signal terminal of one of the oscilloscope probes to TP3 and the ground terminal to TP9. To monitor the output, use the second probe to connect the signal terminal to TP2 and the ground terminal to TP9.
  - 7) Turn on the power supply and check that the power supply current is approximately 1.7 $\mu$ A.
  - 8) Turn on the function generator.
  - 9) Observe the input and output signal. The output signal is an inverted version of the input signal and the swing should be 200mV<sub>PP</sub>.

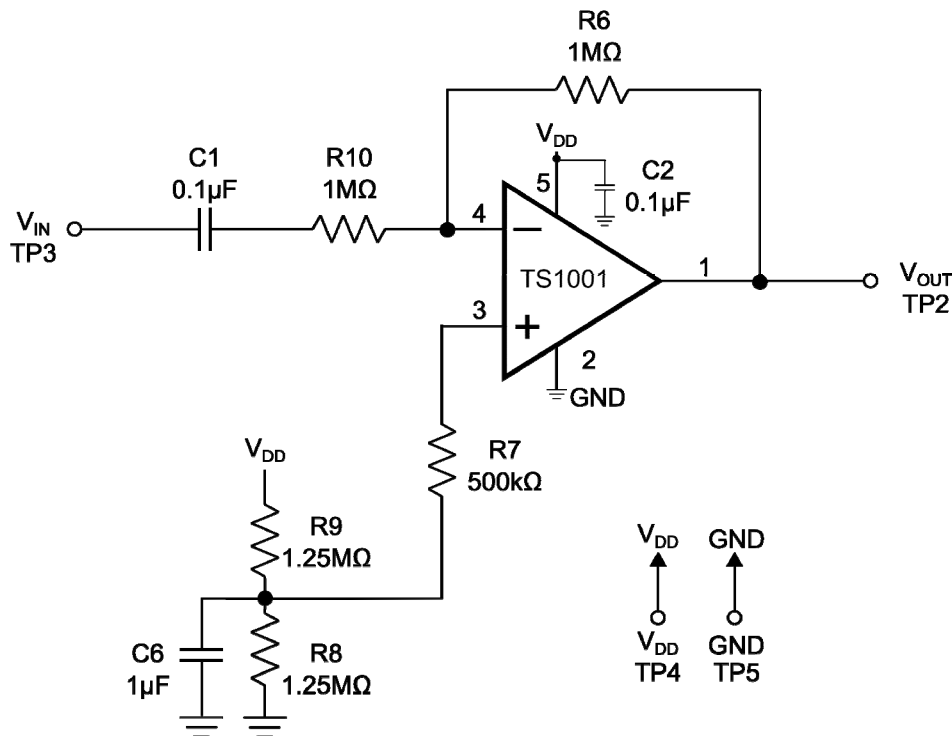

Figure 2. Inverting Configuration

# TS1001 Op Amp Demo Board

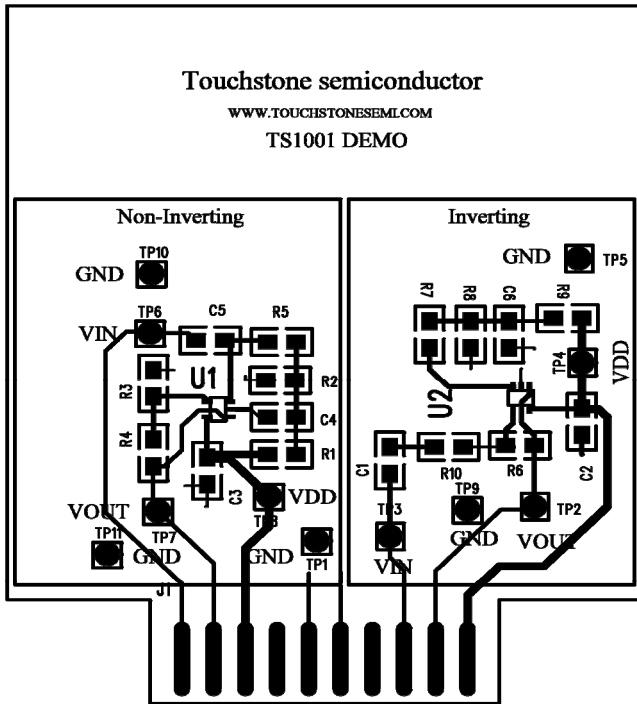

Figure 3. Top Layer Component View

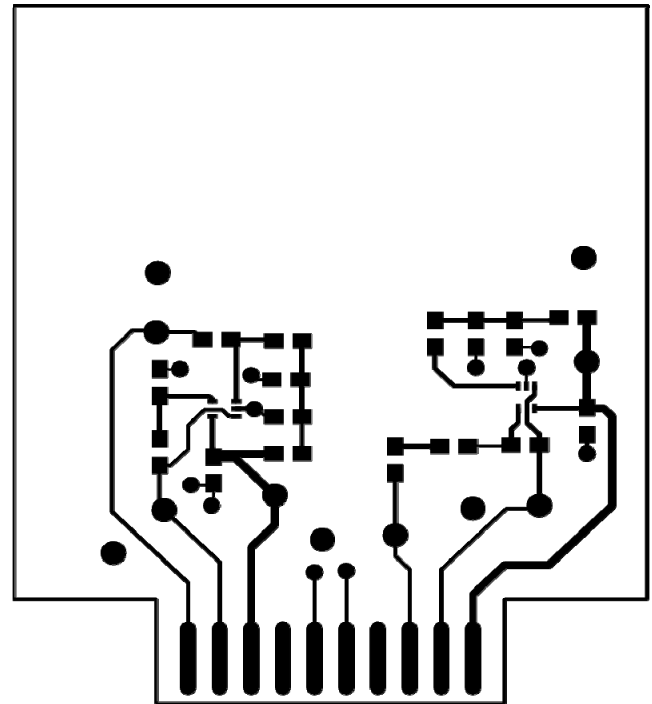

Figure 4. Top Layer Trace View

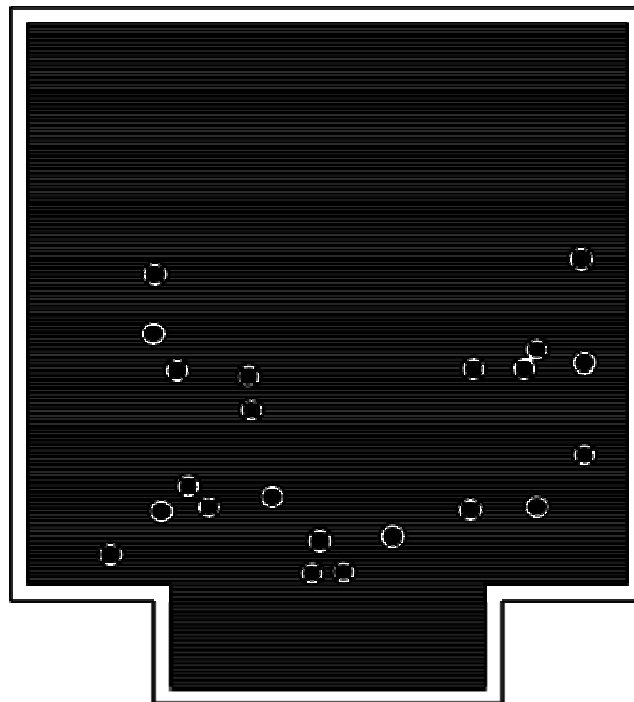

Figure 5. Bottom Layer (GND)

Компания «Life Electronics» занимается поставками электронных компонентов импортного и отечественного производства от производителей и со складов крупных дистрибьюторов Европы, Америки и Азии.

С конца 2013 года компания активно расширяет линейку поставок компонентов по направлению коаксиальный кабель, кварцевые генераторы и конденсаторы (керамические, пленочные, электролитические), за счёт заключения дистрибьюторских договоров

Мы предлагаем:

- Конкурентоспособные цены и скидки постоянным клиентам.
- Специальные условия для постоянных клиентов.
- Подбор аналогов.
- Поставку компонентов в любых объемах, удовлетворяющих вашим потребностям.
- Приемлемые сроки поставки, возможна ускоренная поставка.
- Доставку товара в любую точку России и стран СНГ.
- Комплексную поставку.
- Работу по проектам и поставку образцов.
- Формирование склада под заказчика.
- Сертификаты соответствия на поставляемую продукцию (по желанию клиента).
- Тестирование поставляемой продукции.
- Поставку компонентов, требующих военную и космическую приемку.
- Входной контроль качества.
- Наличие сертификата ISO.

В составе нашей компании организован Конструкторский отдел, призванный помогать разработчикам, и инженерам.

Конструкторский отдел помогает осуществить:

- Регистрацию проекта у производителя компонентов.
- Техническую поддержку проекта.
- Защиту от снятия компонента с производства.
- Оценку стоимости проекта по компонентам.
- Изготовление тестовой платы монтаж и пусконаладочные работы.



Тел: +7 (812) 336 43 04 (многоканальный)  
Email: [org@lifeelectronics.ru](mailto:org@lifeelectronics.ru)