

# NHD-1.8-128160EF-CSXN#-F

## TFT (Thin-Film Transistor) Liquid Crystal Display Module

NHD-	Newhaven Display
1.8-	1.8" Diagonal
128160-	128 x 160 Pixels (Portrait Mode)
EF-	Model
C-	Built-in Controller
S-	Sunlight Readable
X-	TFT
N-	TN, 6:00 Optimal View, Wide Temperature
#-	<b>RoHS Compliant</b>
F-	FFC ZIF Connection Style

**Newhaven Display International, Inc.**

2661 Galvin Ct.

Elgin IL, 60124

Ph: 847-844-8795

Fax: 847-844-8796

[www.newhavendisplay.com](http://www.newhavendisplay.com)

[nhtech@newhavendisplay.com](mailto:nhtech@newhavendisplay.com)

[nhsales@newhavendisplay.com](mailto:nhsales@newhavendisplay.com)

## Document Revision History

Revision	Date	Description	Changed by
0	5/21/15	Initial Release	AK
1	11/5/15	Datasheet Reformat	SB
2	2/26/16	Brightness and Supply Current Updated, Added Backlight Lifetime	SB

## Functions and Features

- 128 x 160 pixels (portrait mode)
- High brightness LED backlight
- Sunlight readable
- 2.8V power supply
- 8-bit Parallel interface
- Built-in ILI9163V controller

# Mechanical Drawing

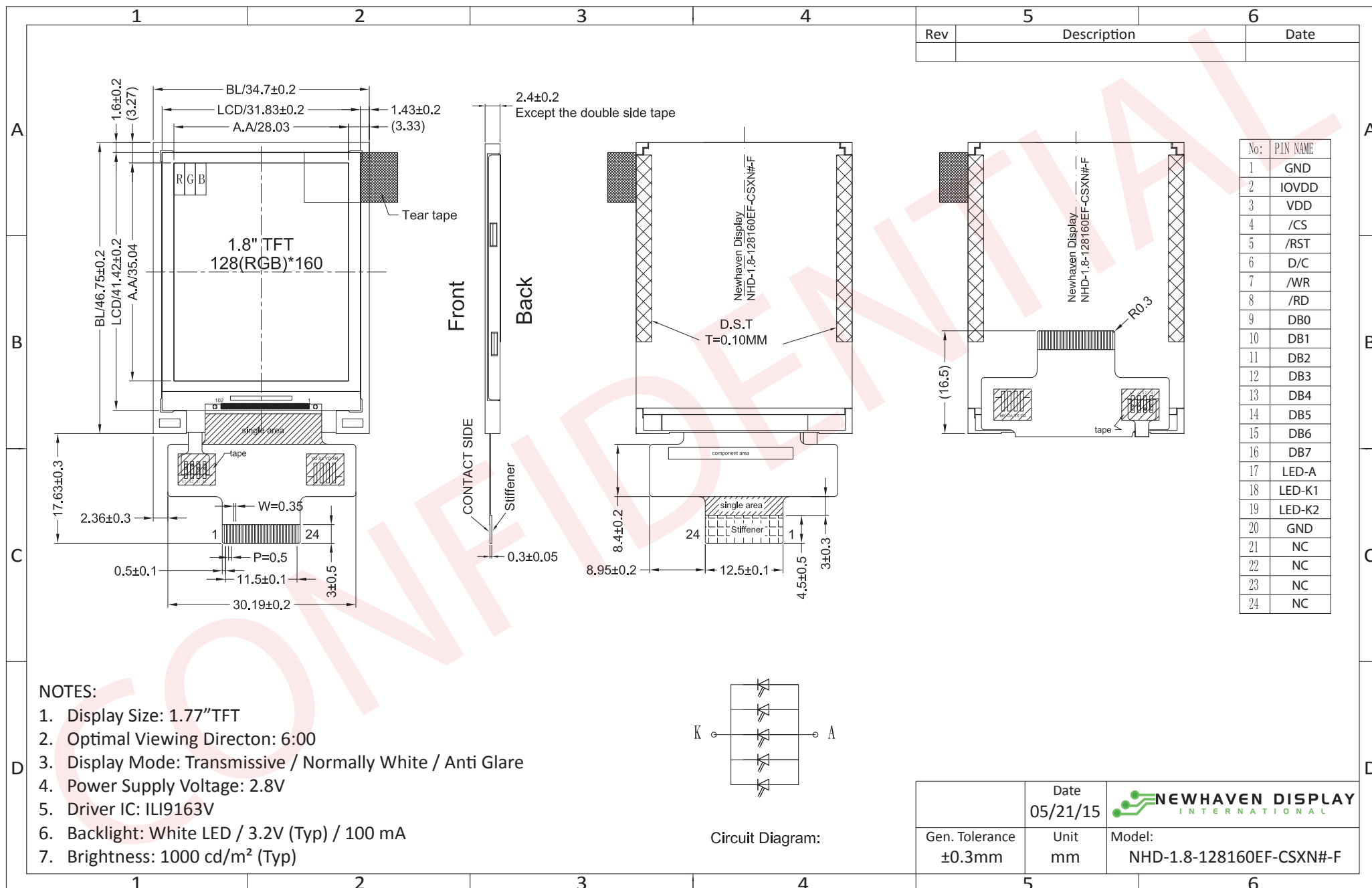

## NOTES:

1. Display Size: 1.77" TFT
2. Optimal Viewing Directon: 6:00
3. Display Mode: Transmissive / Normally White / Anti Glare
4. Power Supply Voltage: 2.8V
5. Driver IC: ILI9163V
6. Backlight: White LED / 3.2V (Typ) / 100 mA
7. Brightness: 1000 cd/m<sup>2</sup> (Typ)

	Date 05/21/15	 <b>NEWHAVEN DISPLAY</b> INTERNATIONAL
Gen. Tolerance ±0.3mm	Unit mm	

The drawing contained herein is the exclusive property of Newhaven Display International, Inc. and shall not be copied, reproduced, and/or disclosed in any format without permission.

## Pin Description and Wiring Diagram

Pin No.	Symbol	External Connection	Function Description
1	GND	Power Supply	Ground
2	IOVDD	Power Supply	Supply Voltage for Logic (2.8V) – Can be tied to VDD
3	VDD	Power Supply	Supply Voltage for LCD (2.8V)
4	/CS	MPU	Active LOW Chip Select signal
5	/RST	MPU	Active LOW Reset signal
6	D/C	MPU	Data / Command selection: '1' = Data ; '0' = Command
7	/WR	MPU	Active LOW Write signal
8	/RD	MPU	Active LOW Read signal
9	DB0	MPU	8-bit bi-directional data bus
10	DB1	MPU	
11	DB2	MPU	
12	DB3	MPU	
13	DB4	MPU	
14	DB5	MPU	
15	DB6	MPU	
16	DB7	MPU	
17	LED-A	Power Supply	Backlight Anode (3.2V)
18	LED-K1	Power Supply	Backlight Cathode (GND)
19	LED-K2	Power Supply	Backlight Cathode (GND)
20	GND	Power Supply	Ground
21	NC	-	No Connect
22	NC	-	No Connect
23	NC	-	No Connect
24	NC	-	No Connect

**LCD connector:** 24pin 0.5mm FFC connector. Molex P/N: 52435-2471

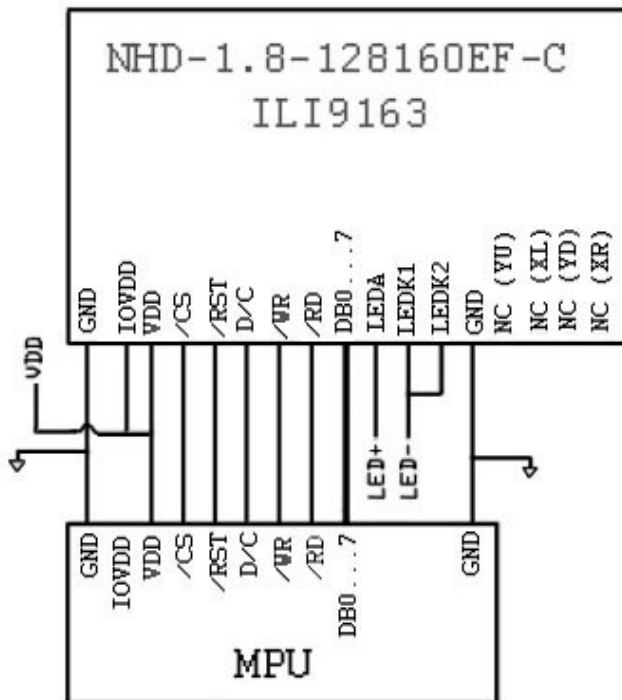

## Electrical Characteristics

Item	Symbol	Condition	Min.	Typ.	Max.	Unit
Operating Temperature Range	Top	Absolute Max	-20	-	+70	°C
Storage Temperature Range	Tst	Absolute Max	-30	-	+80	°C
Supply Voltage for Logic	IOVDD	-	1.65	2.8	3.3	V
Supply Voltage for LCD	VDD	-	2.5	2.8	3.3	V
Supply Current	IDD	-	1	3	5	mA
"H" Level input	Vih	-	0.7*IOVDD	-	IOVDD	V
"L" Level input	Vil	-	GND	-	0.3*IOVDD	V
"H" Level output	Voh	-	0.8*IOVDD	-	IOVDD	V
"L" Level output	Vol	-	GND	-	0.2*IOVDD	V
Backlight Supply Voltage	Vled	-	3.0	3.2	3.4	V
Backlight Supply Current	Iled	Vled=3.2V	-	100	120	mA
Backlight Lifetime*	-	Iled = 100 mA Top = 25° C	20,000	50,000	-	Hrs.

\*Backlight lifetime is rated as Hours until **half-brightness**, under normal operating conditions.

## Optical Characteristics

Item	Symbol	Condition	Min.	Typ.	Max.	Unit
Optimal Viewing Angles	Top	Cr ≥ 10	-	20	-	°
	Bottom		-	50	-	°
	Left		-	45	-	°
	Right		-	45	-	°
Contrast Ratio	Cr	-	400	500	-	-
Luminance	Lv	Iled=100mA	800	1000	-	cd/m <sup>2</sup>
Response Time (rise + fall)	Tr+Tf	-	-	20	30	ms

## Controller Information

Built-in ILI9163V controller.

Please download specification at [http://www.newhavendisplay.com/app\\_notes/ILI9163.pdf](http://www.newhavendisplay.com/app_notes/ILI9163.pdf)

## Table of Commands

Hex Code	Command	Description	Number of Parameters	Display Architecture Implementation Requirement		
				Type 1	Type 2	Type 3
00h	nop	No Operation	0	Yes	Yes	Yes
01h	soft_reset	Software Reset	0	Yes	Yes	Yes
06h	get_red_channel	Get the red component of the pixel at (0, 0).	1	No	Yes	Yes
07h	get_green_channel	Get the green component of the pixel at (0, 0).	1	No	Yes	Yes
08h	get_blue_channel	Get the blue component of the pixel at (0, 0).	1	No	Yes	Yes
0Ch	get_pixel_format	Get the current pixel format.	1	Yes	Yes	Yes
0Ah	get_power_mode	Get the current power mode.	1	Yes	Yes	Yes
0Bh	get_address_mode	Get the frame memory to the display panel read order.	1	Yes	Yes	Yes
0Dh	get_display_mode	Get the current display mode from the peripheral.	1	Yes	Yes	Yes
0Eh	get_signal_mode	Get display module signaling mode.	1	Yes	Yes	Yes
0Fh	get_diagnostic_result	Get Peripheral Self-Diagnostic Result	1	Yes	Yes	Yes
10h	enter_sleep_mode	Power for the display panel is off.	0	Yes	Yes	Yes
11h	exit_sleep_mode	Power for the display panel is on.	0	Yes	Yes	Yes
12h	enter_partial_mode	Part of the display area is used for image display.	0	Yes	Yes	No
13h	enter_normal_mode	The whole display area is used for image display.	0	Yes	Yes	No
20h	exit_invert_mode	Displayed image colors are not inverted.	0	Yes	Yes	Yes
21h	enter_invert_mode	Displayed image colors are inverted.	0	Yes	Yes	Yes
26h	set_gamma_curve	Selects the gamma curve used by the display device.	1	Yes	Yes	Yes
28h	set_display_off	Blanks the display device.	0	Yes	Yes	Yes
29h	set_display_on	Show the image on the display device.	0	Yes	Yes	Yes
2Ah	set_column_address	Set the column extent.	4	Yes	Yes	No
2Bh	set_page_address	Set the page extent.	4	Yes	Yes	No
2Ch	write_memory_start	Transfer image data from the Host Processor to the peripheral starting at the location provided by set_column_address and set_page_address.	Variable	Yes	Yes	No
2Dh	write_LUT	Fills the peripheral look-up table with the provided data.	Variable	optional	No	No
2Eh	read_memory_start	Transfer image data from the peripheral to the Host Processor interface starting at the location provided by set_column_address and set_page_address.	Variable	Yes	Yes	No
30h	set_partial_area	Defines the partial display area on the display device.	4	Yes	Yes	No
33h	set_scroll_area	Defines the vertical scrolling and fixed area on display device.	6	Yes	No	No
34h	set_tear_off	Synchronization information is not sent from the display module to the host processor.	0	Yes	No	No
35h	set_tear_on	Synchronization information is sent from the display module to the host processor at the start of VFP.	1	Yes	No	No

36h	set_address_mode	Set the read order from frame memory to the display panel.	1	Yes	Yes	Yes
37h	set_scroll_start	Defines the vertical scrolling starting point.	2	Yes	No	No
38h	exit_idle_mode	Full color depth is used on the display panel.	0	Yes	No	No
39h	enter_idle_mode	Reduced color depth is used on the display panel.	0	Yes	No	No
3Ah	set_pixel_format	Defines how many bits per pixel are used in the interface.	1	Yes	Yes	Yes
3Ch	write_memory_continue	Transfer image information from the Host Processor interface to the peripheral from the last written location.	Variable	Yes	Yes	No
3Eh	read_memory_continue	Read image data from the peripheral continuing after the last read_memory_continue or read_memory_start.	Variable	Yes	Yes	No
44h	set_tear_scanline	Synchronization information is sent from the display module to the host processor when the display device refresh reaches the provided scanline.	2	Yes	No	No
45h	get_scanline	Get the current scanline.	2	Yes	Yes	No
Dah	Read ID1					
DBh	Read ID2					
DCh	Read ID3					

Notes:

1. There will be no abnormal visible effects on the display when S/W or H/W Reset are applied.
2. After Powered-On Reset finishes within 10 $\mu$ s after both VDD & VDDI are applied.
3. Mode 1 means Tearing Effect Output Line consists of V-Blanking Information only.

For Command Descriptions, please see: [http://www.newhavendisplay.com/app\\_notes/ILI9163.pdf](http://www.newhavendisplay.com/app_notes/ILI9163.pdf)

# Timing Characteristics

## Parallel 8-bit Bus

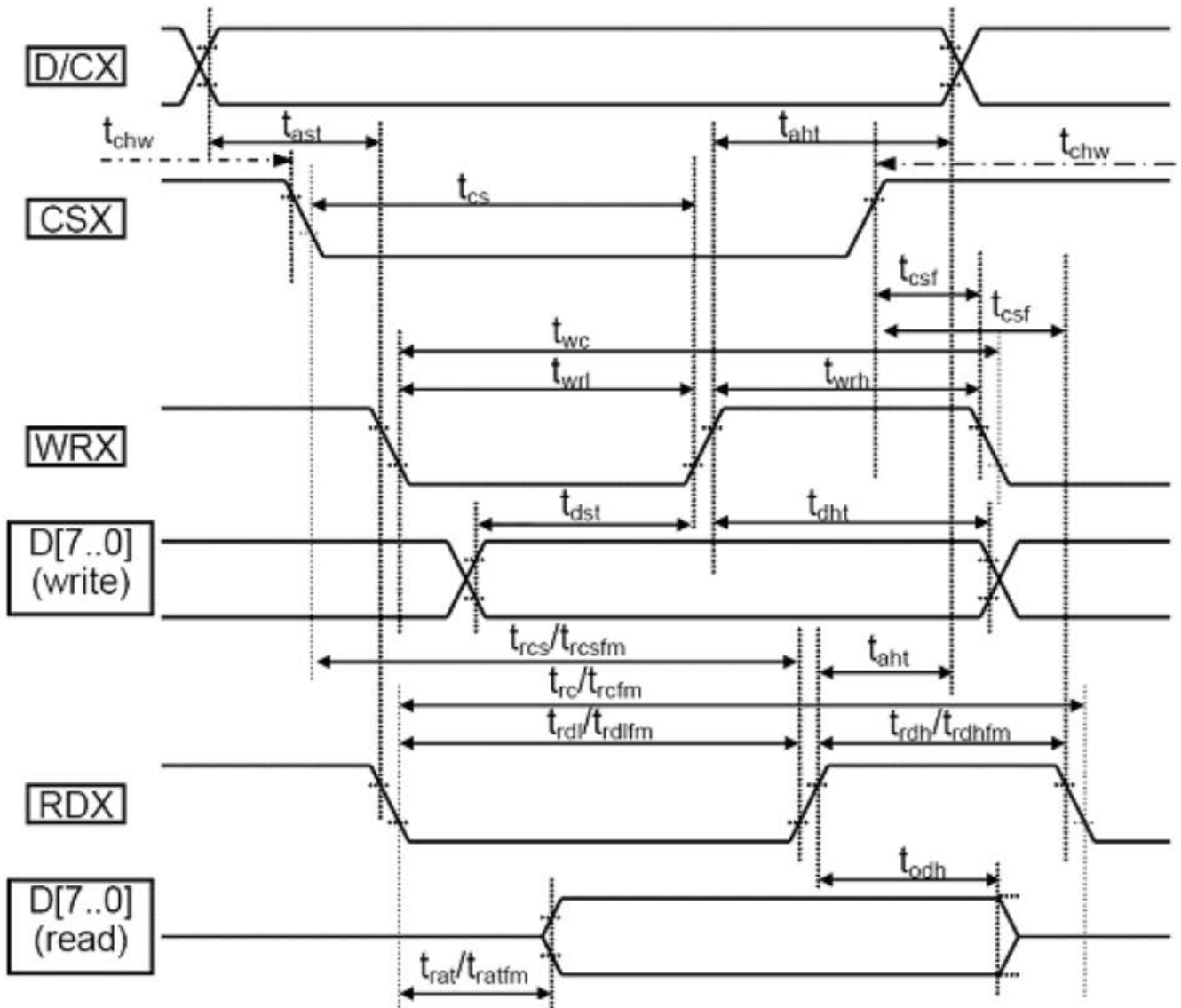

Note: Logic high and low levels are specified as 30% and 70% of VDDI for Input signals.



Signal	Symbol	Parameter	min	max	unit	description
D/CX	tast	Address setup time	0		ns	
	taht	Address hold time(Write/Read)	10		ns	
CSX	tchw	"S""H" Pulse Width	0		ns	
	tcs	Chip Select setup time (Write)	10		ns	
	trcs	Chip Select setup time (Read ID)	45		ns	
	trcsfm	Chip Select setup time (Read FM)	355		ns	
	tcsf	Chip Select Wait time(Write/read)	10		ns	
WRX	twc	Write cycle	66		ns	
	twrh	Control pulse H duration	15		ns	
	twrl	Control pulse L duration	15		ns	
RDX	trc	Read cycle (ID)	160		ns	When read ID data
	trdh	Control pulse H duration(ID)	90		ns	
	trdl	Control pulse L duration(ID)	45		ns	
RDX	trcfm	Read cycle (FM)	450		ns	When read from frame memory
	trdhfm	Control pulse H duration (FM)	90		ns	
	trdlfm	Control pulse L duration (FM)	355		ns	
D[17..0]	tdst	Data setup time	10		ns	For maximum CL = 30pF For minimum CL = 8pF
	tdht	Data hold time	10		ns	
	trat	Read access time (ID)		40	ns	
	tratfm	Read access time (FM)		340	ns	
	todh	Output disable time	20	80	ns	

Note 1: VDDI 1.65 to 3.3V, VDD=2.6 to 3.3V, AGND=GND=0V, Ta=-30 to 70 °C (to +85°C no damage)

Note 2: This input signal rise time and fall time (tr, tf) is specified at 15 ns or less. Logic high and low levels are specified as 30% and 70% of VDDI for input signals

### Reset Timing

Item	Symbol	Unit	Min.	Typ.	Max.
Reset low-level width	$t_{RES}$	ms	1	-	-
Reset rise time	$t_{rRES}$	$\mu$ S	-	-	10

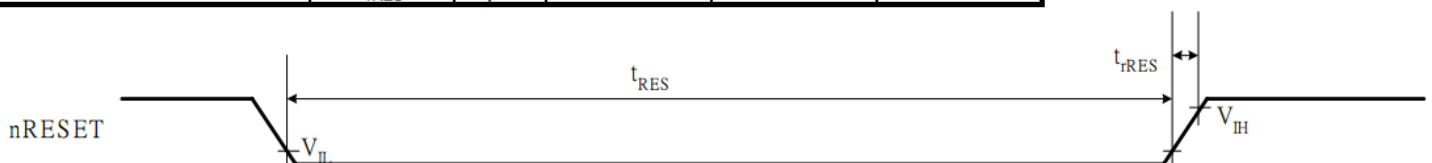

## Example Program Code

```
void TFT_18E_Init(void)
{
    GPIO_ResetBits(GPIOC, CS1);
    GPIO_SetBits(GPIOC, nRD);
    GPIO_ResetBits(GPIOC, nWR);
    GPIO_WriteBit(GPIOC, RES, Bit_RESET);
    delay(5);
    TFT_delay(10);
    GPIO_WriteBit(GPIOC, RES, Bit_SET);
    delay(100);
    TFT_delay(10);
    TFT_18E_Write_Command(0x11);
    TFT_delay(100);
    TFT_18E_Write_Command(0x26);TFT_18E_Write_Data(0x04);
    TFT_18E_Write_Command(0xF2);TFT_18E_Write_Data(0x00);
    TFT_18E_Write_Command(0xB1);TFT_18E_Write_Data(0x0A);TFT_18E_Write_Data(0x14);
    TFT_18E_Write_Command(0xC0);TFT_18E_Write_Data(0x0A);TFT_18E_Write_Data(0x00);
    TFT_18E_Write_Command(0xC1);TFT_18E_Write_Data(0x02);
    TFT_18E_Write_Command(0xC5);TFT_18E_Write_Data(0x2F);TFT_18E_Write_Data(0x3E);
    TFT_18E_Write_Command(0xC7);TFT_18E_Write_Data(0x40);
    TFT_18E_Write_Command(0x2A);
    TFT_18E_Write_Data(0x00);
    TFT_18E_Write_Data(0x00);
    TFT_18E_Write_Data(0x00);
    TFT_18E_Write_Data(0x7F);
    TFT_18E_Write_Command(0x2B);
    TFT_18E_Write_Data(0x00);
    TFT_18E_Write_Data(0x00);
    TFT_18E_Write_Data(0x00);
    TFT_18E_Write_Data(0x9F);
    TFT_18E_Write_Command(0x36);TFT_18E_Write_Data(0x48);
    TFT_18E_Write_Command(0x3A);TFT_18E_Write_Data(0xC5);
    TFT_18E_Write_Command(0x29);
    TFT_18E_Write_Command(0x2C);
}
/*****/
void TFT_18E_Write_Command(unsigned char command)
{
    GPIO_ResetBits(GPIOC, RS);
    GPIO_Write(GPIOB, command);
    GPIO_ResetBits(GPIOC, nWR);
    GPIO_SetBits(GPIOC, nWR);
}
/*****/
void TFT_18E_Write_Data(unsigned char data1)
{
    GPIO_SetBits(GPIOC, RS);
    GPIO_Write(GPIOB, data1);
    GPIO_ResetBits(GPIOC, nWR);
    GPIO_SetBits(GPIOC, nWR);
}
/*****/
```

## Quality Information

Test Item	Content of Test	Test Condition	Note
High Temperature storage	Endurance test applying the high storage temperature for a long time.	+80°C , 48hrs	2
Low Temperature storage	Endurance test applying the low storage temperature for a long time.	-30°C , 48hrs	1,2
High Temperature Operation	Endurance test applying the electric stress (voltage & current) and the high thermal stress for a long time.	+70°C , 48hrs	2
Low Temperature Operation	Endurance test applying the electric stress (voltage & current) and the low thermal stress for a long time.	-20°C , 48hrs	1,2
High Temperature / Humidity Operation	Endurance test applying the electric stress (voltage & current) and the high thermal with high humidity stress for a long time.	+50°C , 90% RH , 48hrs	1,2
Thermal Shock resistance	Endurance test applying the electric stress (voltage & current) during a cycle of low and high thermal stress.	-20°C 30 min ~ +70°C 30 min, 10 cycles	
Vibration test	Endurance test applying vibration to simulate transportation and use.	10-55Hz , 1.5mm amplitude. 2 hours in each of 3 directions X,Y,Z. For 6 hours total	3
Static electricity test	Endurance test applying electric static discharge.	VS=4KV, RS=330Ω, CS=150pF Five times	

**Note 1:** No condensation to be observed.

**Note 2:** Conducted after 4 hours of storage at 25°C, 0%RH.

**Note 3:** Test performed on product itself, not inside a container.

## Precautions for using LCDs/LCMs

See Precautions at [www.newhavendisplay.com/specs/precautions.pdf](http://www.newhavendisplay.com/specs/precautions.pdf)

## Warranty Information

See Terms & Conditions at [http://www.newhavendisplay.com/index.php?main\\_page=terms](http://www.newhavendisplay.com/index.php?main_page=terms)

Компания «Life Electronics» занимается поставками электронных компонентов импортного и отечественного производства от производителей и со складов крупных дистрибьюторов Европы, Америки и Азии.

С конца 2013 года компания активно расширяет линейку поставок компонентов по направлению коаксиальный кабель, кварцевые генераторы и конденсаторы (керамические, пленочные, электролитические), за счёт заключения дистрибьюторских договоров

Мы предлагаем:

- Конкурентоспособные цены и скидки постоянным клиентам.
- Специальные условия для постоянных клиентов.
- Подбор аналогов.
- Поставку компонентов в любых объемах, удовлетворяющих вашим потребностям.
- Приемлемые сроки поставки, возможна ускоренная поставка.
- Доставку товара в любую точку России и стран СНГ.
- Комплексную поставку.
- Работу по проектам и поставку образцов.
- Формирование склада под заказчика.
- Сертификаты соответствия на поставляемую продукцию (по желанию клиента).
- Тестирование поставляемой продукции.
- Поставку компонентов, требующих военную и космическую приемку.
- Входной контроль качества.
- Наличие сертификата ISO.

В составе нашей компании организован Конструкторский отдел, призванный помогать разработчикам, и инженерам.

Конструкторский отдел помогает осуществить:

- Регистрацию проекта у производителя компонентов.
- Техническую поддержку проекта.
- Защиту от снятия компонента с производства.
- Оценку стоимости проекта по компонентам.
- Изготовление тестовой платы монтаж и пусконаладочные работы.



Тел: +7 (812) 336 43 04 (многоканальный)  
Email: [org@lifeelectronics.ru](mailto:org@lifeelectronics.ru)