

# Si5397/96 Data Sheet

## Dual/Quad DSPLL™ Any-Frequency, Any-Output Jitter Attenuators

The Si5397 is a high-performance, 8-output jitter-attenuating clock multiplier which integrates four any-frequency DSPLLs for applications that require maximum integration and independent timing paths. The Si5396 is a 4-output, dual DSPLL version in a smaller package. Each DSPLL has access to any of the four inputs and can provide low jitter clocks on any of the device outputs. Device grades J/K/L/M have an integrated reference to save board space, improve system reliability and reduces the effect of acoustic emissions noise caused by temperature ramps. Grades A/B/C/D use an external crystal (XTAL) or crystal oscillator (XO) reference.

Based on 4<sup>th</sup> generation DSPLL technology, these devices provide any-frequency conversion with typical jitter performance of 95 fs. Each DSPLL supports independent free-run, holdover modes of operation, as well as automatic and hitless input clock switching. The Si5397/96 is programmable via a serial interface with in-circuit programmable non-volatile memory so that it always powers up in a known configuration. Programming the Si5397/96 is easy with Silicon Labs' [ClockBuilder™ Pro](#) software. Factory pre-programmed devices are also available.

### Applications

- OTN Muxponders and Transponders
- 10/40/100/400GbE
- Synchronous Ethernet (ITU-T G.8262)
- 10/25/100G Carrier Ethernet switches
- Broadcast video

### KEY FEATURES

- Each DSPLL generates any output frequency from any input frequency
- Four or two DSPLLs to synchronize to multiple time domains
- Ultra-low phase jitter of 95 fs rms
- Enhanced hitless switching minimizes output phase transients
- Input frequency range:
  - Differential: 8 kHz to 750 MHz
  - LVCMOS: 8 kHz to 250 MHz
- Output frequency range:
  - Differential: 100 Hz to 720 MHz
  - LVCMOS: 100 Hz to 250 MHz
- Status Monitoring
- Si5397: 4 input, 8 output, 64-QFN 9×9 mm
- Si5396: 4 input, 4 output, 44-QFN 7×7 mm
- External reference: Grades A/B/C/D
- Integrated reference: Grades J/K/L/M
- Drop-in compatible with Si5347/46

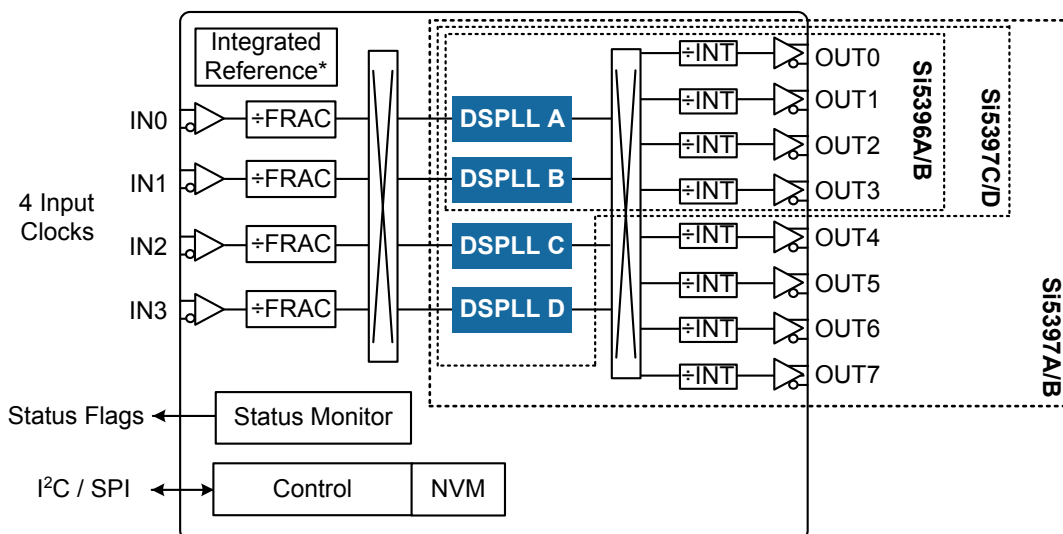

\*Only for Si539x J/K/L/M grades. Si539x A/B/C/D grades have external reference (XTAL or XO)

## 1. Feature List

The Si5397/96 features are listed below:

- Generates any combination of output frequencies from any input frequency
- External XTAL or XO reference (A/B/C/D)
- Integrated reference (J/K/L/M)
- Ultra-low phase jitter of 95 fs rms
- Four or two DSPLLs to synchronize to multiple inputs
- Input frequency range:
  - Differential: 8 kHz to 750 MHz
  - LVCMOS: 8 kHz to 250 MHz
- Output frequency range:
  - Differential: up to 720 MHz
  - LVCMOS: up to 250 MHz
- Flexible crosspoints route any input to any output clock
- Programmable jitter attenuation bandwidth per DSPLL: 0.1 Hz to 4 kHz
- Highly configurable outputs compatible with LVDS, LVPECL, LVCMOS, CML, and HCSL with programmable signal amplitude
- Status monitoring (LOS, OOF, LOL)
- Enhanced hitless switching minimizes output phase transients for 8 kHz, 19.44 MHz, 25 MHz, and other input frequencies
- Drop-in compatible with Si5347/46
- Locks to gapped clock inputs
- Automatic free-run and holdover modes
- Fastlock feature for low nominal bandwidths
- Independent Frequency-on-the-fly for each DSPLL
- DCO mode: as low as 0.01 ppb steps per DSPLL
- Core voltage:
  - $V_{DD}$ : 1.8 V  $\pm$ 5%
  - $V_{DDA}$ : 3.3 V  $\pm$ 5%
- Independent output clock supply pins: 3.3, 2.5, or 1.8 V
- Serial interface: I<sup>2</sup>C or SPI
- In-circuit programmable with non-volatile OTP memory
- ClockBuilder™ Pro software tool simplifies device configuration
- Si5397A/B
  - Quad DSPLL, 4 input, 8 output, 64-QFN 9×9 mm
- Si5397C/D
  - Quad DSPLL, 4 input, 4 output, 64-QFN 9×9 mm
- Si5396
  - Dual DSPLL, 4 input, 4 output, 44-QFN 7×7 mm
- Temperature range: -40 to +85 °C
- Pb-free, RoHS-6 compliant

## 2. Related Documents

**Table 2.1. Related Documentation and Software**

Document/Resource	Description/URL
Si5397/96 Family Reference Manual	<a href="#">Si5397/96 Family Reference Manual</a> The reference manual is intended to be used in conjunction with this data sheet, which contains more detailed explanations about the operation of the device.
Crystal Reference Manual (Grades A/B/C/D only)	<a href="https://www.silabs.com/documents/public/reference-manuals/si534x-8x-9x-recommended-crystals-rm.pdf">https://www.silabs.com/documents/public/reference-manuals/si534x-8x-9x-recommended-crystals-rm.pdf</a>
UG336: Si5396 Evaluation Board User's Guide	<a href="https://www.silabs.com/documents/public/user-guides/ug336-si5396evb.pdf">https://www.silabs.com/documents/public/user-guides/ug336-si5396evb.pdf</a>
UG353: Si5397 Evaluation Board User's Guide	<a href="https://www.silabs.com/documents/public/user-guides/ug353-si5397evb.pdf">https://www.silabs.com/documents/public/user-guides/ug353-si5397evb.pdf</a>
AN1151: Using the Si539x in 56G SerDes Applications	<a href="https://www.silabs.com/documents/public/application-notes/an1151-using-si539x.pdf">https://www.silabs.com/documents/public/application-notes/an1151-using-si539x.pdf</a>
AN1155: Differences between Si5342-47 and Si5392-97	<a href="https://www.silabs.com/documents/public/application-notes/an1155-differences-between-si5342-47-and-si5392-97.pdf">https://www.silabs.com/documents/public/application-notes/an1155-differences-between-si5342-47-and-si5392-97.pdf</a>
AN1178: Frequency-On-the-Fly for Silicon Labs Jitter Attenuators and Clock Generators	<a href="https://www.silabs.com/documents/public/application-notes/an1178-frequency-otf-jitter-atten-clock-gen.pdf">https://www.silabs.com/documents/public/application-notes/an1178-frequency-otf-jitter-atten-clock-gen.pdf</a>
Frequently Asked Questions	<a href="http://www.silabs.com/Si5397-96FAQ">http://www.silabs.com/Si5397-96FAQ</a>
Quality and Reliability	<a href="http://www.silabs.com/quality">http://www.silabs.com/quality</a>
Development Kits	<a href="https://www.silabs.com/products/development-tools/timing/clock#highperformance">https://www.silabs.com/products/development-tools/timing/clock#highperformance</a>
ClockBuilder Pro (CBPro) Software	<a href="https://www.silabs.com/products/development-tools/software/clockbuilder-pro-software">https://www.silabs.com/products/development-tools/software/clockbuilder-pro-software</a>

### 3. Ordering Guide

Table 3.1. Si5397/96 A/B/C/D Ordering Guide (External Reference)

Ordering Part Number	Number Of DSPLLs	Number of Input/Output Clocks	Output Clock Frequency Range	Package	Reference
<b>Si5397</b>					
Si5397A-A-GM <sup>1,2</sup>	4	4/8	0.0001 to 720 MHz	64-QFN 9x9 mm	External
Si5397B-A-GM <sup>1,2</sup>			0.0001 to 350 MHz		
Si5397C-A-GM <sup>1,2</sup>		4/4	0.0001 to 720 MHz		
Si5397D-A-GM <sup>1,2</sup>			0.0001 to 350 MHz		
Si5397A-A-EVB	—	8-output	—	Evaluation Board	
<b>Si5396</b>					
Si5396A-A-GM <sup>1,2</sup>	2	4/4	0.0001 to 720 MHz	44-QFN 7x7 mm	External
Si5396B-A-GM <sup>1,2</sup>			0.0001 to 350 MHz		
<b>Notes:</b>					
1. Add an R at the end of the device part number to denote tape and reel ordering options.					
2. Custom, factory pre-programmed devices are available. Ordering part numbers are assigned by the ClockBuilder Pro software. Part number format is: Si5397A-Axxxxx-GM or Si5396A-Axxxxx-GM, where “xxxxx” is a unique numerical sequence representing the pre-programmed configuration.					

Table 3.2. Si5397/6 J/K/L/M Ordering guide (Integrated Reference)

Ordering Part Number	Number Of DSPLLs	Number of Input/Output Clocks	Output Clock Frequency Range	Package	Reference
<b>Si5397</b>					
Si5397J-A-GM <sup>1,2</sup>	4	4/8	0.0001 to 720 MHz	64-LGA 9x9 mm	Internal
Si5397K-A-GM <sup>1,2</sup>			0.0001 to 350 MHz		
Si5397L-A-GM <sup>1,2</sup>		4/4	0.0001 to 720 MHz		
Si5397M-A-GM <sup>1,2</sup>			0.0001 to 350 MHz		
Si5397J-A-EVB	—	8-output	—	Evaluation Board	
<b>Si5396</b>					
Si5396J-A-GM <sup>1,2</sup>	2	4/4	0.0001 to 720 MHz	44-LGA 7x7 mm	Internal
Si5396K-A-GM <sup>1,2</sup>			0.0001 to 350 MHz		
Si5396J-A-EVB	—	4-output	—	Evaluation Board	
<b>Notes:</b>					
1. Add an R at the end of the device part number to denote tape and reel ordering options.					
2. Custom, factory pre-programmed devices are available. Ordering part numbers are assigned by the ClockBuilder Pro software. Part number format is: Si5397A-Axxxxx-GM or Si5396A-Axxxxx-GM, where “xxxxx” is a unique numerical sequence representing the pre-programmed configuration.					

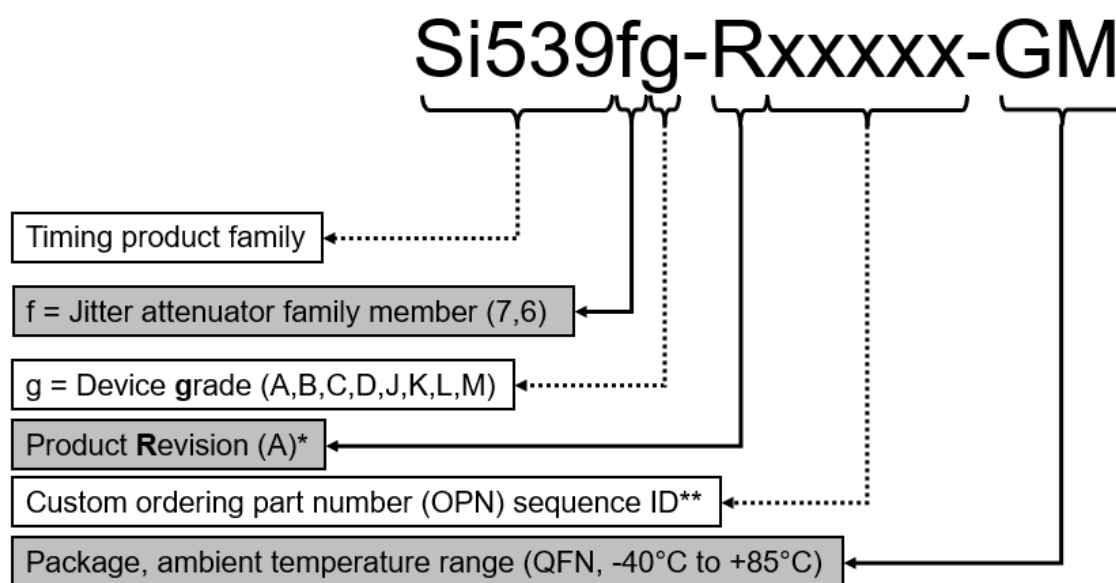

\*See Ordering Guide table for current product revision.

\*\* (Optional) 5 digits; assigned by ClockBuilder Pro for Custom, factory-preprogrammed OPN devices only; (The “xxxxx” field is not included for “Base” OPNs).

Figure 3.1. Ordering Part Number Fields

# Table of Contents

<b>1. Feature List</b>	<b>2</b>
<b>2. Related Documents</b>	<b>3</b>
<b>3. Ordering Guide</b>	<b>4</b>
<b>4. Functional Description</b>	<b>8</b>
4.1 Frequency Configuration	8
4.2 DSPLL Loop Bandwidth	8
4.3 Fastlock Feature	8
4.4 Modes of Operation	9
4.4.1 Initialization and Reset	9
4.4.2 Free-run Mode	9
4.4.3 Lock Acquisition Mode	10
4.4.4 Locked Mode	10
4.4.5 Holdover Mode	10
4.4.6 Frequency-on-the-Fly (FOTF)	10
4.5 Digitally-Controlled Oscillator (DCO) Mode	11
4.6 External Reference (Grade A/B/C/D Only)	11
4.7 Inputs (IN0, IN1, IN2, IN3)	12
4.7.1 Input Selection	12
4.7.2 Manual Input Selection	12
4.7.3 Automatic Input Selection	12
4.7.4 Hitless Input Switching	12
4.7.5 Frequency Ramped Input Switching	12
4.7.6 Glitchless Input Switching	12
4.7.7 Typical Hitless Switching Scenarios	13
4.7.8 Synchronizing to Gapped Input Clocks	14
4.8 Fault Monitoring	15
4.8.1 Input LOS Detection	15
4.8.2 XA/XB LOS Detection	15
4.8.3 OOF Detection	16
4.8.4 LOL Detection	17
4.8.5 Interrupt Pin (INTRb)	18
4.9 Outputs	18
4.9.1 Output Crosspoint	18
4.9.2 Output Signal Format	18
4.9.3 Programmable Common Mode Voltage For Differential Outputs	18
4.9.4 LVCMOS Output Impedance Selection	18
4.9.5 LVCMOS Output Signal Swing	18
4.9.6 LVCMOS Output Polarity	18
4.9.7 Output Enable/Disable	19
4.9.8 Output Disable During LOL	19
4.9.9 Output Disable During XAXB_LOS	19
4.9.10 Output Driver State When Disabled	19

4.9.11 Synchronous/Asynchronous Output Disable . . . . .	.19
4.9.12 Output Divider (R) Synchronization . . . . .	.19
4.10 Power Management . . . . .	.19
4.11 In-Circuit Programming. . . . .	.19
4.12 Serial Interface . . . . .	.19
4.13 Custom Factory Preprogrammed Parts . . . . .	.20
4.14 Register Map . . . . .	.20
<b>5. Electrical Specifications . . . . .</b>	<b>21</b>
<b>6. Typical Application Schematic . . . . .</b>	<b>37</b>
<b>7. Detailed Block Diagrams . . . . .</b>	<b>38</b>
<b>8. Typical Operating Characteristics (Jitter and Phase Noise) . . . . .</b>	<b>40</b>
<b>9. Pin Descriptions . . . . .</b>	<b>42</b>
<b>10. Package Outlines . . . . .</b>	<b>49</b>
10.1 Si5397 9x9 mm 64-QFN Package Diagram . . . . .	.49
10.2 Si5397 9x9 mm 64-LGA Package Diagram . . . . .	.50
10.3 Si5396 7x7 mm 44-QFN Package Diagram . . . . .	.51
10.4 Si5396 7x7 mm 44-LGA Package Diagram . . . . .	.52
<b>11. PCB Land Pattern . . . . .</b>	<b>53</b>
<b>12. Top Marking . . . . .</b>	<b>55</b>
<b>13. Revision History. . . . .</b>	<b>56</b>

## 4. Functional Description

The Si5397/96 multi-PLL Jitter attenuators take advantage of Silicon Labs' 4<sup>th</sup> generation DSPLL technology to offer the industry's most integrated and flexible jitter attenuating clock generator solution. Each of the DSPLLs operate independently from each other and are controlled through a common serial interface. Each DSPLL has access to any of the four inputs (IN0 to IN3) with manual or automatic input selection. Any of the output clocks (OUT0 to OUT7) can be configured to any of the DSPLLs using a flexible crosspoint connection. The Si5396 is a smaller form factor dual DSPLL version with four inputs and four outputs.

### 4.1 Frequency Configuration

The frequency configuration for each of the DSPLLs is programmable through the serial interface and can also be stored in non-volatile memory. The combination of fractional input dividers ( $P_n/P_d$ ), fractional frequency multiplication ( $M_n/M_d$ ), and integer output division ( $R_n$ ) allows each of the DSPLLs to lock to any input frequency and generate virtually any output frequency. All divider values for a specific frequency plan are easily determined using the ClockBuilder Pro utility.

### 4.2 DSPLL Loop Bandwidth

The DSPLL loop bandwidth determines the amount of input clock jitter attenuation. Register-configurable DSPLL loop bandwidth settings in the range of 0.1 Hz to 4 kHz are available for selection for each of the DSPLLs. Since the loop bandwidth is controlled digitally, each of the DSPLLs will always remain stable with less than 0.1 dB of peaking regardless of the loop bandwidth selection.

### 4.3 Fastlock Feature

Selecting a low DSPLL loop bandwidth (e.g. 0.1 Hz) will generally lengthen the lock acquisition time. The fastlock feature allows setting a temporary Fastlock Loop Bandwidth that is used during the lock acquisition process. Higher fastlock loop bandwidth settings will enable the DSPLLs to lock faster. Fastlock Loop Bandwidth settings in the range of 100 Hz to 4 kHz are available for selection. The DSPLL will revert to its normal loop bandwidth once lock acquisition has completed.



## 4.4 Modes of Operation

Once initialization is complete, each of the DSPLLs operates independently in one of four modes: Free-run Mode, Lock Acquisition Mode, Locked Mode, or Holdover Mode. A state diagram showing the modes of operation is shown in the figure below. The following sections describe each of these modes in greater detail.

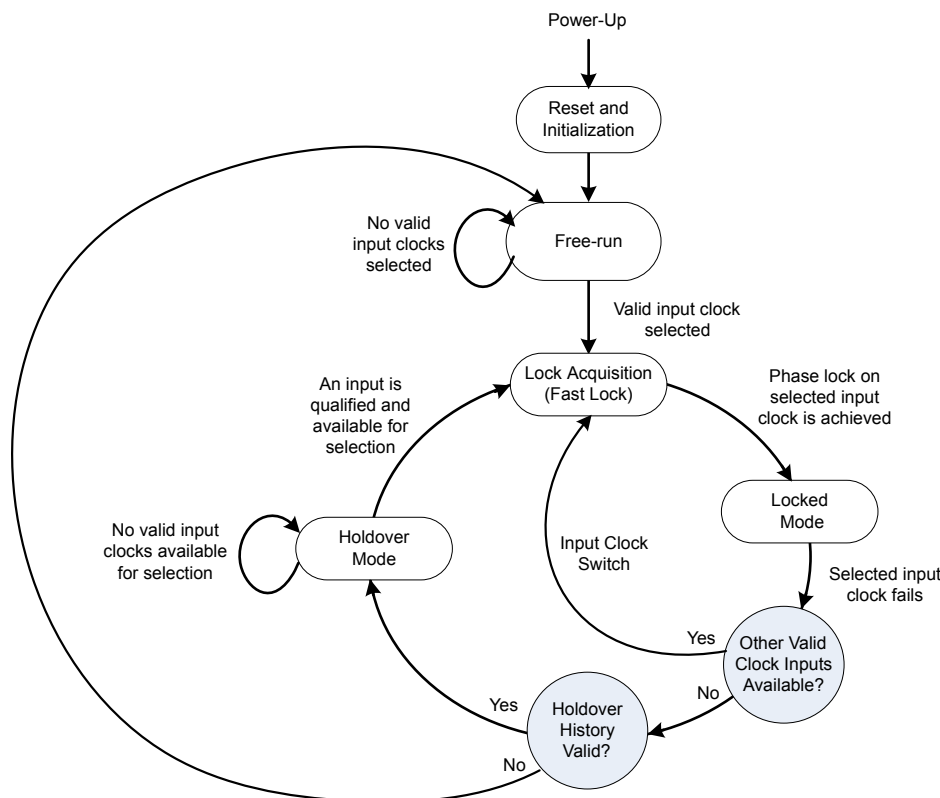

Figure 4.1. Modes of Operation

### 4.4.1 Initialization and Reset

Once power is applied, the device begins an initialization period where it downloads default register values and configuration data from NVM and performs other initialization tasks. Communicating with the device through the serial interface is possible once this initialization period is complete. No clocks will be generated until the initialization is complete.

Clocks that feature the integrated crystal may require a slightly longer settling time compared to the external crystal device. See the Reference Manual for more details.

There are two types of resets available. A hard reset is functionally similar to a device power-up. All registers will be restored to the values stored in NVM, and all circuits including the serial interface will be restored to their initial state. A hard reset is initiated using the RSTb pin or by asserting the hard reset register bit.

A soft reset bypasses the NVM download. It is simply used to initiate register configuration changes.

### 4.4.2 Free-run Mode

All four DSPLLs will automatically enter freerun mode once power is applied to the device and initialization is complete. The frequency accuracy of the generated output clocks in Free-run Mode is entirely dependent on the frequency accuracy of the external crystal or reference clock on the XA/XB pins. For example, if the crystal frequency is  $\pm 100$  ppm, then all the output clocks will be generated at their configured frequency  $\pm 100$  ppm in Free-run Mode. Any drift of the crystal frequency will be tracked at the output clock frequencies. A TCXO or OCXO is recommended for applications that need better frequency accuracy and stability while in Free-run Mode or Holdover Mode.

### 4.4.3 Lock Acquisition Mode

Each of the DSPLLs independently monitors its configured inputs for a valid clock. If at least one valid clock is available for synchronization, a DSPLL will automatically start the lock acquisition process.

If the fast lock feature is enabled, a DSPLL will acquire lock using the Fastlock Loop Bandwidth setting and then transition to the DSPLL Loop Bandwidth setting when lock acquisition is complete. During lock acquisition the outputs will generate a clock that follows the VCO frequency change as it pulls-in to the input clock frequency.

### 4.4.4 Locked Mode

Once locked, a DSPLL will generate output clocks that are both frequency and phase locked to their selected input clocks. At this point, any XTAL frequency drift will not affect the output frequency. Each DSPLL has its own LOL pin and status bit to indicate when lock is achieved. See [4.8.4 LOL Detection](#) for more details on the operation of the loss of lock circuit.

### 4.4.5 Holdover Mode

Any of the DSPLLs will automatically enter Holdover Mode when the selected input clock becomes invalid and no other valid input clocks are available for selection. Each DSPLL uses an averaged input clock frequency as its final holdover frequency to minimize the disturbance of the output clock phase and frequency when an input clock suddenly fails. The holdover circuit for each DSPLL stores up to 120 seconds of historical frequency data while locked to a valid clock input. The final averaged holdover frequency value is calculated from a programmable window within the stored historical frequency data. Both the window size and delay are programmable, as shown in the figure below. The window size determines the amount of holdover frequency averaging. The delay value allows ignoring frequency data that may be corrupt just before the input clock failure.

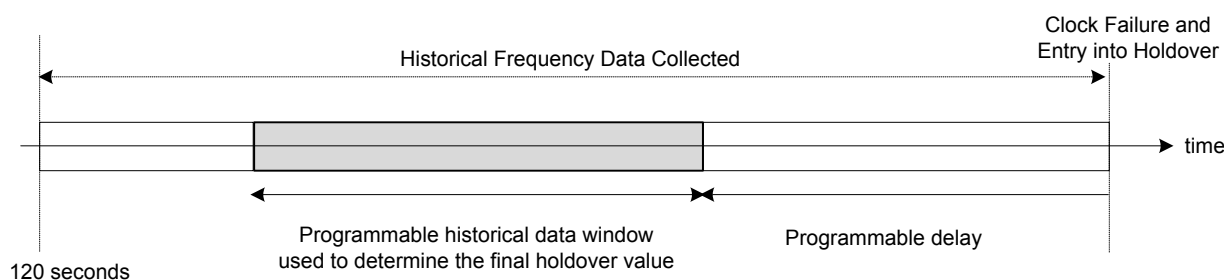

**Figure 4.2. Programmable Holdover Window**

When entering Holdover Mode, a DSPLL will pull its output clock frequency to the calculated averaged holdover frequency. While in Holdover Mode, the output frequency drift is entirely dependent on the external crystal or external reference clock connected to the XA/XB pins. If the clock input becomes valid, a DSPLL will automatically exit the Holdover Mode and reacquire lock to the new input clock. This process involves pulling the output clock frequencies to achieve frequency and phase lock with the input clock. This pull-in process is glitchless, and its rate is controlled by the DSPLL bandwidth or the fastlock bandwidth. These options are register programmable.

The DSPLL output frequency when exiting holdover can be ramped (recommended). Just before the exit is initiated, the difference between the current holdover frequency and the new desired frequency is measured. Using the calculated difference and a user-selectable ramp rate, the output is linearly ramped to the new frequency. The ramp rate can be 0.2 ppm/s, 40,000 ppm/s, or any of about 40 values in between. The DSPLL loop BW does not limit or affect ramp rate selections (and vice versa). CBPro defaults to ramped exit from holdover. The same ramp rate settings are used for both exit from holdover and ramped input switching. For more information on ramped input switching, see [4.7.5 Frequency Ramped Input Switching](#).

**Note:** If ramped holdover exit is not selected, the holdover exit is governed either by (1) the DSPLL loop BW or (2) a user-selectable holdover exit BW.

### 4.4.6 Frequency-on-the-Fly (FOTF)

The Si5397/96 uses register writes to support configuration on the fly to allow certain characteristics to be changed on one DSPLL without affecting the clocks generated from other DSPLLs. These characteristics include Input/Output Frequencies, PLL bandwidth, LOL, and OOF settings. See the [Si5397/96 Family Reference Manual](#) and [AN1178: Frequency-On-the-Fly for Silicon Labs Jitter Attenuators and Clock Generators](#) for more details.

#### 4.5 Digitally-Controlled Oscillator (DCO) Mode

The DSPLLs support a DCO mode where their output frequencies are adjustable in predefined steps defined by frequency step words (FSW). The frequency adjustments are controlled through the serial interface or by pin control using frequency increment (FINC) or decrement (FDEC). A FINC will add the frequency step word to the DSPLL output frequency, while a FDEC will decrement it. The DCO mode is available when the DSPLL is operating in either Free-run or Locked Mode.

#### 4.6 External Reference (Grade A/B/C/D Only)

An external crystal (XTAL) is used in combination with the internal oscillator (OSC) to produce an ultra-low jitter reference clock for the DSPLLs and for providing a stable reference for the Free-run and Holdover Modes. A simplified diagram is shown in the figure below. The device includes internal XTAL loading capacitors, which eliminates the need for external capacitors and also has the benefit of reduced noise coupling from external sources. Refer to [Table 5.12 External Crystal Specifications for Grades A/B/C/D<sup>1</sup>](#) on page 34 for crystal specifications. A crystal in the range of 48 MHz to 54 MHz is recommended for best jitter performance. The [Si5397/96 Family Reference Manual](#) provides additional information on PCB layout recommendations for the crystal to ensure optimum jitter performance.

To achieve optimal jitter performance and minimize BOM cost, a crystal is recommended on the XA/XB reference input. For SyncE line card PLL applications (e.g. loop bandwidth set to 0.1 Hz), a TCXO is required on the XA/XB reference to minimize wander and to provide a stable holdover reference. See the [Si5397/96 Family Reference Manual](#) for more information. Selection between the external XTAL or REFCLK is controlled by register configuration. The internal crystal loading capacitors ( $C_L$ ) are disabled in the REFCLK mode. Refer to [Table 5.3 Input Clock Specifications](#) on page 23 for REFCLK requirements when using this mode. The [Si5397/96 Family Reference Manual](#) provides additional information on PCB layout recommendations for the crystal to ensure optimum jitter performance. A  $P_{REF}$  divider is available to accommodate external clock frequencies higher than 54 MHz. Although the REFCLK frequency range of 25 MHz to 54 MHz is supported, frequencies in the range of 48 MHz to 54 MHz will achieve the best output jitter performance.

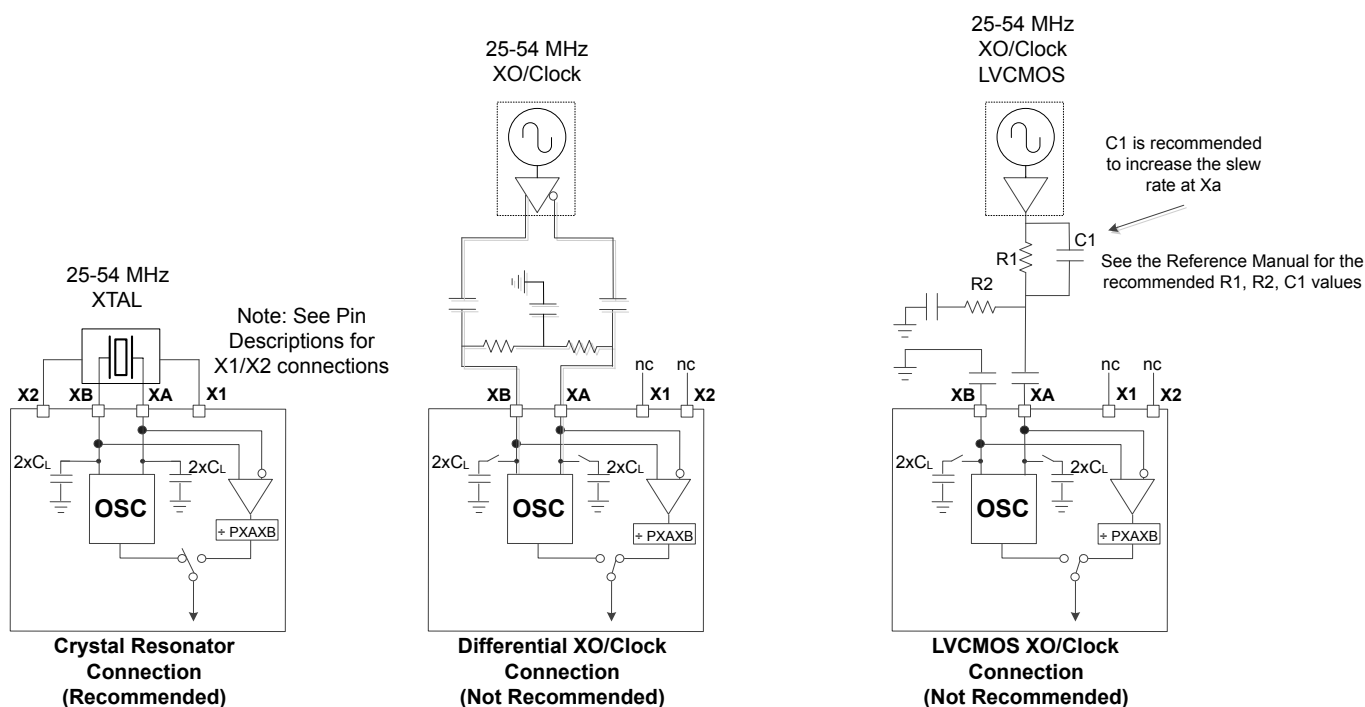

Note: XA and XB must not exceed the maximum input voltage listed in [Table 5.3 Input Clock Specifications](#) on page 24

Figure 4.3. Crystal Resonator and External Reference Clock Connection Options

Note: Connecting an external reference to a device that already has an integrated reference (grades J/K/L/M) is not allowed. Doing so could lead to internal damage to the circuits.

## 4.7 Inputs (IN0, IN1, IN2, IN3)

The Si5397 has four inputs that can be synchronized with four DSPLLs. The Si5396 has four inputs that can be synchronized with two DSPLLs. The inputs accept both differential and single-ended clocks. A crosspoint between the inputs and the DSPLLs allows any of the inputs to connect to any of the DSPLLs.

### 4.7.1 Input Selection

Input selection for each of the DSPLLs can be made manually through register control or automatically using an internal state machine.

### 4.7.2 Manual Input Selection

In Manual Mode, the input selection is made by writing to a register. If there is no clock signal on the selected input, the DSPLL will automatically enter Holdover Mode.

### 4.7.3 Automatic Input Selection

When configured in this mode, the DSPLL automatically selects a valid input that has the highest configured priority. The priority scheme is independently configurable for each DSPLL and supports revertive or non-revertive selection.

All inputs are continuously monitored for loss of signal (LOS) and/or invalid frequency range (OOF). Only inputs that do not assert both the LOS and OOF monitors can be selected for synchronization by the automatic state machine. The DSPLL(s) will enter the Holdover mode if there are no valid inputs available.

### 4.7.4 Hitless Input Switching

Hitless switching is a feature that prevents a phase offset from propagating to the output when switching between two clock inputs that have a fixed phase relationship. A hitless switch can only occur when the two input frequencies are frequency locked, meaning that they have to be exactly at the same frequency, or at an integer frequency relationship to each other. When hitless switching is enabled, the DSPLL simply absorbs the phase difference between the two input clocks during an input switch. When disabled, the phase difference between the two inputs is propagated to the output at a rate determined by the DSPLL Loop Bandwidth. The hitless switching feature supports clock frequencies down to the minimum input frequency of 8 kHz; however, for optimum hitless switching performance, higher input frequencies are recommended. Hitless switching can be enabled on a per DSPLL basis.

### 4.7.5 Frequency Ramped Input Switching

The ramped input switching feature is enabled/disabled depending on both the frequency of the Phase-Frequency detector (Fpfd) and the difference in input frequencies (Zero-PPM vs non-zero PPM). The table below shows the selection criteria to enable ramped input switching. The same ramp rate settings are used for both holdover exit and clock switching. For more information on ramped exit from holdover, see [4.4.5 Holdover Mode](#) and the [Si5397/96 Family Reference Manual](#).

**Table 4.1. Recommended Ramped Input Switching Settings for Internal Clock Switches**

Maximum Input Frequency Difference	Fpfd < 500 kHz	Fpfd ≥ 500 kHz
<b>0 ppm Frequency Locked</b>	Ramped Exit from Holdover	
<b>≤ 10 ppm</b>	Ramped Input Switching and Ramped Exit from Holdover	Ramped Exit from Holdover
<b>&gt; 10 ppm</b>	Ramped Input Switching and Ramped Exit from Holdover	
<b>Note:</b>		
1. The Fpfd value is determined by various requirements of the frequency plan and is displayed in the CBPro project file.		

Always enable hitless switching and enable phase buildout on holdover exit. In CBPro these selections are in Step 14 of 18 DSPLL configure.

### 4.7.6 Glitchless Input Switching

The DSPLLs have the ability of switching between two input clock frequencies that are up to ±500 ppm apart. The DSPLL will pull-in to the new frequency using the DSPLL Loop Bandwidth or using the Fastlock Loop Bandwidth if it is enabled. The loss of lock (LOL) indicator will assert while the DSPLL is pulling-in to the new clock frequency. There will be no output runt pulses generated at the output during the transition.

4.7.7 Typical Hitless Switching Scenarios

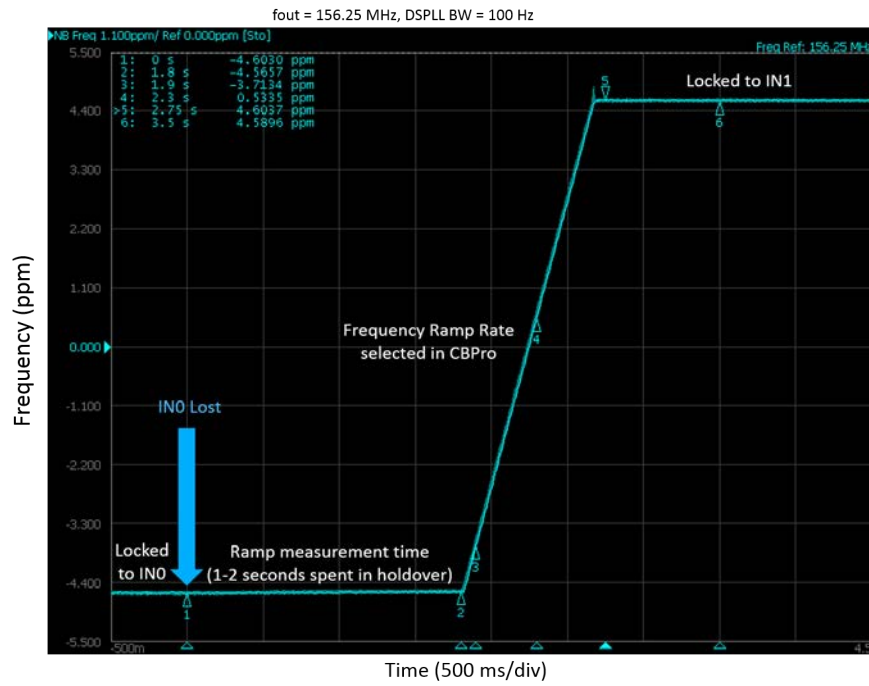

Figure 4.4. Output Frequency Transient—Ramped Switching between Two 8 kHz Inputs ( $\pm 4.6$  ppm Offset)

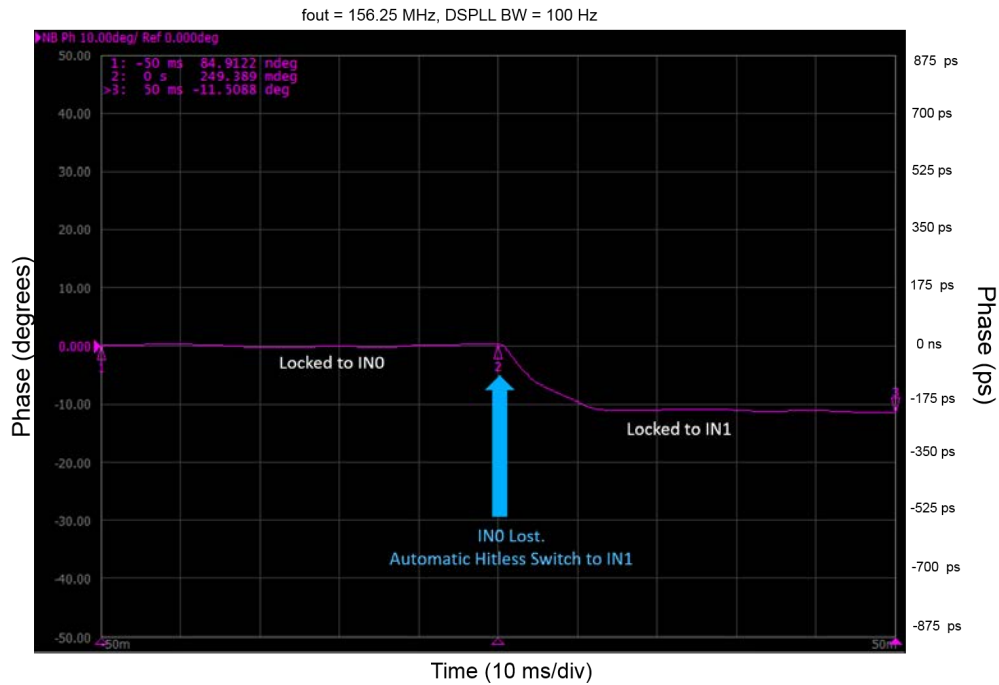
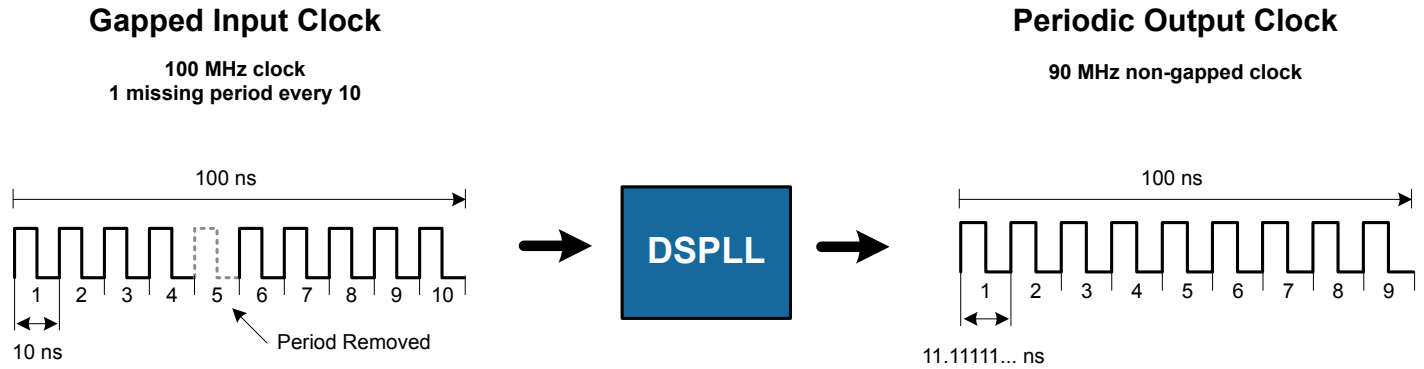

Figure 4.5. Output Phase Transient—Hitless Switching between Two 25 MHz Inputs (0 ppm, 180 Degree Phase Shift)

### 4.7.8 Synchronizing to Gapped Input Clocks

Each of the DSPLLs support locking to an input clock that has missing periods. This is also referred to as a gapped clock. The purpose of gapped clocking is to modulate the frequency of a periodic clock by selectively removing some of its cycles. Gapping a clock severely increases its jitter, so a phase-locked loop with high jitter tolerance and low loop bandwidth is required to produce a low-jitter periodic clock. The resulting output will be a periodic non-gapped clock with an average frequency of the input with its missing cycles. For example, an input clock of 100 MHz with one cycle removed every 10 cycles will result in a 90 MHz periodic non-gapped output clock. This is shown in the figure below.



**Figure 4.6. Generating an Averaged Clock Output Frequency from a Gapped Clock Input**

A valid gapped clock input must have a minimum frequency of 10 MHz with a maximum of two missing cycles out of every 8. Locking to a gapped clock will not trigger the LOS, OOF, and LOL fault monitors. Clock switching between gapped clocks may violate the hitless switching specification in [Table 5.8 Performance Characteristics on page 30](#) when the switch occurs during a gap in either input clock.

### 4.8 Fault Monitoring

All four input clocks (IN0, IN1, IN2, IN3) are monitored for LOS and OOF, as shown in the figure below. The reference at the XA/XB pins is also monitored for LOS since it provides a critical reference clock for the DSPLLs. Each of the DSPLLs also has an LOL indicator, which is asserted when synchronization is lost with their selected input clock.

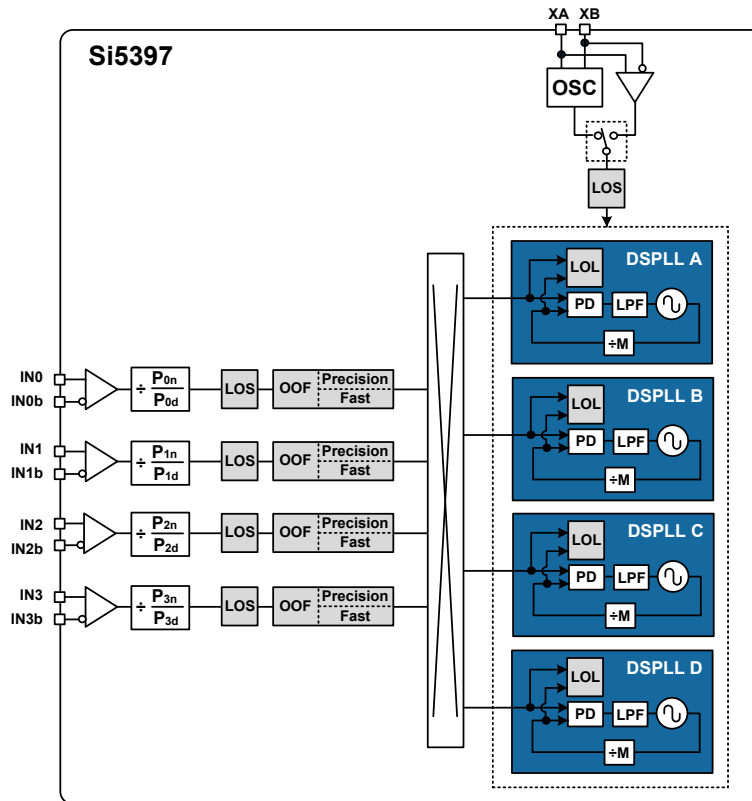

Figure 4.7. Si5397 Fault Monitors

#### 4.8.1 Input LOS Detection

The loss of signal monitor measures the period of each input clock cycle to detect phase irregularities or missing clock edges. Each of the input LOS circuits has its own programmable sensitivity which allows ignoring missing edges or intermittent errors. Loss of signal sensitivity is configurable using the ClockBuilder Pro utility. The LOS status for each of the monitors is accessible by reading a status register. The live LOS register always displays the current LOS state and a sticky register always stays asserted until cleared. An option to disable any of the LOS monitors is also available.

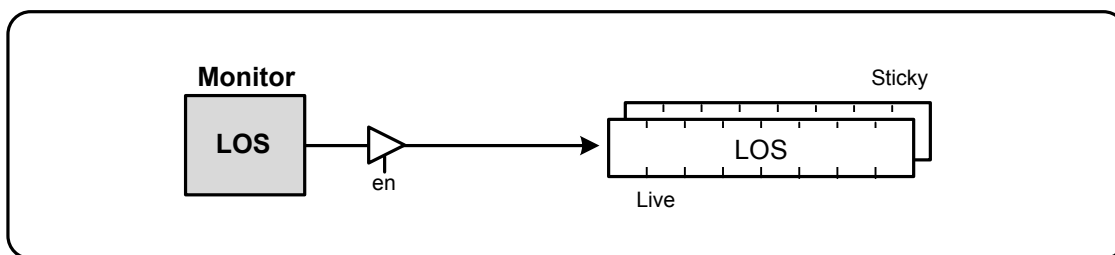

Figure 4.8. LOS Status Indicators

#### 4.8.2 XA/XB LOS Detection

A LOS monitor is available to ensure that the external crystal or reference clock is valid. By default the output clocks are disabled when XAXB\_LOS is detected. This feature can be disabled such that the device will continue to produce output clocks when XAXB\_LOS is detected.

### 4.8.3 OOF Detection

Each input clock is monitored for frequency accuracy with respect to an OOF reference, which it considers as its “0\_ppm” reference.

This OOF reference can be selected as either:

- XA/XB pins
- Any input clock (IN0, IN1, IN2, IN3)

The final OOF status is determined by the combination of both a precise OOF monitor and a fast OOF monitor, as shown in the figure below. An option to disable either monitor is also available. The live OOF register always displays the current OOF state and its sticky register bit stays asserted until cleared.

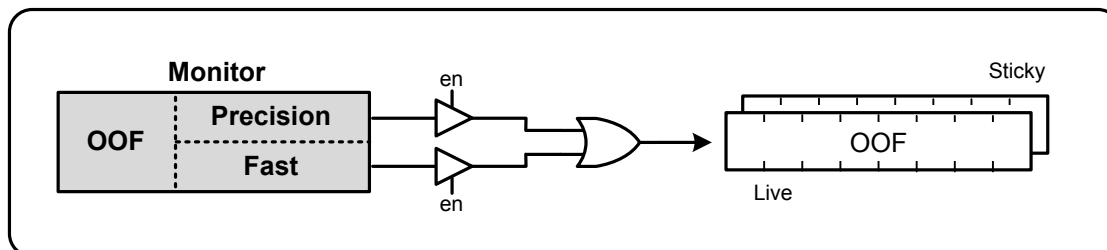

Figure 4.9. OOF Status Indicator

#### 4.8.3.1 Precision OOF Monitor

The precision OOF monitor circuit measures the frequency of all input clocks to within 1/16 ppm accuracy with respect to the selected OOF frequency reference. A valid input clock frequency is one that remains within the OOF frequency range, which is register configurable up to  $\pm 512$  ppm in steps of 1/16 ppm. A configurable amount of hysteresis is also available to prevent the OOF status from toggling at the failure boundary. An example is shown in the figure below. In this case, the OOF monitor is configured with a valid frequency range of  $\pm 6$  ppm and with 2 ppm of hysteresis. An option to use one of the input pins (IN0 – IN3) as the 0 ppm OOF reference instead of the XA/XB pins is available. This option is register-configurable.

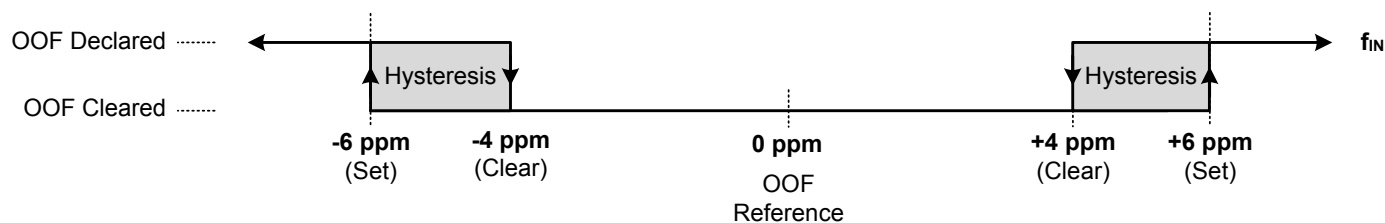

Figure 4.10. Example of Precise OOF Monitor Assertion and De-assertion Triggers

#### 4.8.3.2 Fast OOF Monitor

Because the precision OOF monitor needs to provide 1/16 ppm of frequency measurement accuracy, it must measure the monitored input clock frequencies over a relatively long period of time. This may be too slow to detect an input clock that is quickly ramping in frequency. An additional level of OOF monitoring called the Fast OOF monitor runs in parallel with the precision OOF monitors to quickly detect a ramping input frequency. The Fast OOF monitor asserts OOF on an input clock frequency that has changed by greater than  $\pm 4000$  ppm.



#### 4.8.4 LOL Detection

There is an LOL monitor for each of the DSPLLs. The LOL monitor asserts an LOL register bit when a DSPLL has lost synchronization with its selected input clock. There is also a dedicated loss of lock pin that reflects the loss of lock condition for each of the DSPLLs (LOL\_Ab, LOL\_Bb, LOL\_Cb, LOL\_Db). The LOL monitor functions by measuring the frequency difference between the input and feedback clocks at the phase detector. There are two LOL frequency monitors, one that sets the LOL indicator (LOL Set) and another that clears the indicator (LOL Clear). An optional timer is available to delay clearing of the LOL indicator to allow additional time for the DSPLL to completely lock to the input clock. The timer is also useful to prevent the LOL indicator from toggling or chattering as the DSPLL completes lock acquisition. A block diagram of the LOL monitor is shown in the figure below. The live LOL register always displays the current LOL state and a sticky register always stays asserted until cleared. The LOLb pin reflects the current state of the LOL monitor.

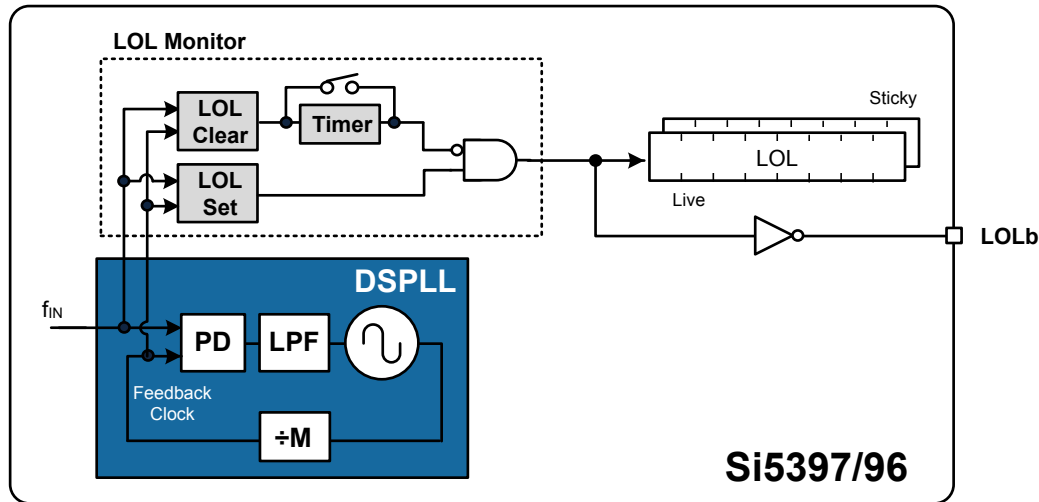

Figure 4.11. LOL Status Indicators

Each of the LOL frequency monitors has adjustable sensitivity, which is register-configurable from 0.1 ppm to 10,000 ppm. Having two separate frequency monitors allows for hysteresis to help prevent chattering of LOL status. An example configuration where LOCKED is indicated when there is less than 0.1 ppm frequency difference at the inputs of the phase detector and LOL is indicated when there is more than 1 ppm frequency difference is shown in the figure below.

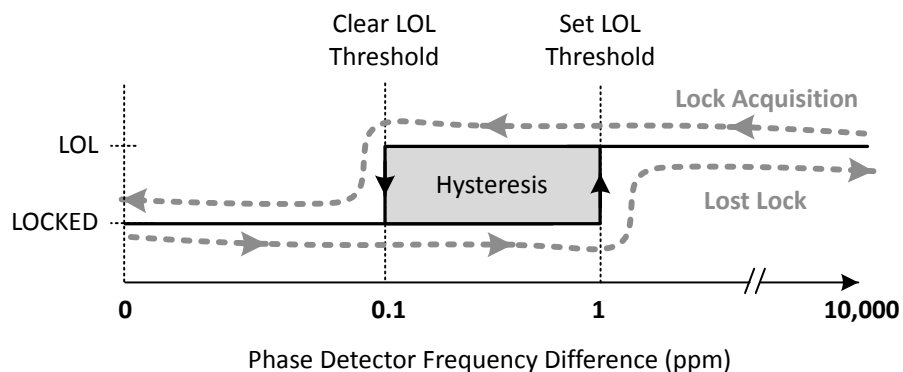

Figure 4.12. LOL Set and Clear Thresholds

An optional timer is available to delay clearing of the LOL indicator to allow additional time for the DSPLL to completely lock to the input clock. The timer is also useful to prevent the LOL indicator from toggling or chattering as the DSPLL completes lock acquisition. The configurable delay value depends on frequency configuration and loop bandwidth of the DSPLL and is automatically calculated using the ClockBuilderPro utility.

#### 4.8.5 Interrupt Pin (INTRb)

An interrupt pin (INTRb) indicates a change in state of the status indicators (LOS, OOF, LOL, HOLD). Any of the status indicators are maskable to prevent assertion of the interrupt pin. The state of the INTRb pin is reset by clearing the status register that caused the interrupt.

#### 4.9 Outputs

The Si5397 supports up to eight differential output drivers and the Si5396 supports four. Each driver has a configurable voltage amplitude and common mode voltage covering a wide variety of differential signal formats including LVPECL, LVDS, HCSL, and CML. In addition to supporting differential signals, any of the outputs can be configured as single-ended LVCMOS (3.3 V, 2.5 V, or 1.8 V) providing up to 16 single-ended outputs, or any combination of differential and single-ended outputs.

##### 4.9.1 Output Crosspoint

A crosspoint allows any of the output drivers to connect with any of the DSPLLs, as shown in the figure below. The crosspoint configuration is programmable and can be stored in NVM so that the desired output configuration is ready at power-up.

##### 4.9.2 Output Signal Format

The differential output amplitude and common mode voltage are both fully programmable and compatible with a wide variety of signal formats, including LVDS and LVPECL. In addition to supporting differential signals, any of the outputs can be configured as LVCMOS (3.3 V, 2.5 V, or 1.8 V) drivers providing up to 16 single-ended outputs or any combination of differential and single-ended outputs.

##### 4.9.3 Programmable Common Mode Voltage For Differential Outputs

The common mode voltage ( $V_{CM}$ ) for the differential modes is programmable and depends on the voltage available at the output's VDDO pin. Setting the common mode voltage is useful when dc-coupling the output drivers.

##### 4.9.4 LVCMOS Output Impedance Selection

Each LVCMOS driver has a configurable output impedance to accommodate different trace impedances and drive strengths. A source termination resistor is recommended to help match the selected output impedance to the trace impedance. There are three programmable output impedance selections for each VDDO option, as shown in the table below. Note that selecting a lower source impedance may result in higher output power consumption.

**Table 4.2. Typical Output Impedance ( $Z_S$ )**

VDDO	CMOS_DRIVE_Selection		
	OUTx_CMOS_DRV = 1	OUTx_CMOS_DRV = 2	OUTx_CMOS_DRV = 3
3.3 V	38 $\Omega$	30 $\Omega$	22 $\Omega$
2.5 V	43 $\Omega$	35 $\Omega$	24 $\Omega$
1.8 V	—	46 $\Omega$	31 $\Omega$

##### 4.9.5 LVCMOS Output Signal Swing

The signal swing ( $V_{OL}/V_{OH}$ ) of the LVCMOS output drivers is set by the voltage on the VDDO pins. Each output driver has its own VDDO pin allowing a unique output voltage swing for each of the LVCMOS drivers.

##### 4.9.6 LVCMOS Output Polarity

When a driver is configured as an LVCMOS output, it generates a clock signal on both pins (OUTx and OUTxb). By default the clock on the OUTxb pin is generated with the same polarity (in phase) with the clock on the OUTx pin. The polarity of these clocks is configurable, which enables complementary clock generation and/or inverted polarity with respect to other output drivers.

#### 4.9.7 Output Enable/Disable

The Si5397/96 allows enabling/disabling outputs by pin or register control, or a combination of both. Two output enable pins are available (OE0b, OE1b). The output enable pins can be mapped to any of the outputs (OUTx) through register configuration. By default OE0b controls all of the outputs while OE1b remains unmapped and has no effect until configured. The figure below shows an example of an output enable mapping scheme that is register configurable and can be stored in NVM as the default at power-up.

Enabling and disabling outputs can also be controlled by register control. This allows disabling one or more output when the OEb pin(s) has them enabled. By default the output enable register settings are configured to allow the OEb pins to have full control.

#### 4.9.8 Output Disable During LOL

By default a DSPLL that is out of lock will generate either free-running clocks or generate clocks in holdover mode. There is an option to disable the outputs when a DSPLL is LOL. This option can be useful to force a downstream PLL into holdover.

#### 4.9.9 Output Disable During XAXB\_LOS

The internal oscillator circuit (OSC) in combination with the external crystal (XTAL) provides a critical function for the operation of the DSPLLs. In the event of a crystal failure the device will assert an XAXB\_LOS alarm. By default all outputs will be disabled during assertion of the XAXB\_LOS alarm. There is an option to leave the outputs enabled during an XAXB\_LOS alarm, but the frequency accuracy and stability will be indeterminate during this fault condition.

#### 4.9.10 Output Driver State When Disabled

The disabled state of an output driver is register configurable as disable low or disable high.

#### 4.9.11 Synchronous/Asynchronous Output Disable

Outputs can be configured to disable synchronously or asynchronously. In synchronous disable mode the output will wait until a clock period has completed before the driver is disabled. This prevents unwanted runt pulses from occurring when disabling an output. In asynchronous disable mode, the output clock will disable immediately without waiting for the period to complete.

#### 4.9.12 Output Divider (R) Synchronization

All the output R dividers are reset to a known state during the power-up initialization period. This ensures consistent and repeatable phase alignment across all output drivers. Resetting the device using the RSTb pin or asserting the hard reset bit will have the same result.

### 4.10 Power Management

Unused inputs, output drivers, and DSPLLs can be powered down when unused. Consult the [Si5397/96 Family Reference Manual](#) and ClockBuilder Pro configuration utility for details.

### 4.11 In-Circuit Programming

The Si5397/96 is fully configurable using the serial interface (I<sup>2</sup>C or SPI). At power-up the device downloads its default register values from internal non-volatile memory (NVM). Application specific default configurations can be written into NVM allowing the device to generate specific clock frequencies at power-up. Writing default values to NVM is in-circuit programmable with normal operating power supply voltages applied to its V<sub>DD</sub> and V<sub>DDA</sub> pins. The NVM is two time writable. Once a new configuration has been written to NVM, the old configuration is no longer accessible. Refer to the [Si5397/96 Family Reference Manual](#) for a detailed procedure for writing registers to NVM.

### 4.12 Serial Interface

Configuration and operation of the Si5397/96 is controlled by reading and writing registers using the I<sup>2</sup>C or SPI interface. The I2C\_SEL pin selects I<sup>2</sup>C or SPI operation. Communication with both 3.3 V and 1.8 V host is supported. The SPI mode operates in either 4-wire or 3-wire mode. See the [Si5397/96 Family Reference Manual](#) for details.

### 4.13 Custom Factory Preprogrammed Parts

For applications where a serial interface is not available for programming the device, custom pre-programmed parts can be ordered with a specific configuration written into NVM. A factory pre-programmed part will generate clocks at power-up. Custom, factory-pre-programmed devices are available. Use the ClockBuilder Pro custom part number wizard ([www.silabs.com/clockbuilderpro](http://www.silabs.com/clockbuilderpro)) to quickly and easily request and generate a custom part number for your configuration.

In less than three minutes, you will be able to generate a custom part number with a detailed data sheet addendum matching your design's configuration. Once you receive the confirmation email with the data sheet addendum, simply place an order with your local Silicon Labs sales representative. Samples of your pre-programmed device will typically ship in about two weeks.

### 4.14 Register Map

The register map is divided into multiple pages where each page has 256 addressable registers. Page 0 contains frequently accessible registers, such as alarm status, resets, device identification, etc. Other pages contain registers that need less frequent access, such as frequency configuration and general device settings. Refer to the [Si5397/96 Family Reference Manual](#) for a complete list of register descriptions and settings. It is strongly recommended that [ClockBuilder Pro](#) be used to create and manage register settings.

## 5. Electrical Specifications

**Table 5.1. Recommended Operating Conditions**

Parameter	Symbol	Min	Typ	Max	Unit
Ambient Temperature	$T_A$	-40	25	85	°C
Junction Temperature	$T_{JMAX}$	—	—	125	°C
Core Supply Voltage	$V_{DD}$	1.71	1.80	1.89	V
	$V_{DDA}$	3.14	3.30	3.47	V
Output Driver Supply Voltage	$V_{DDO}$	3.14	3.30	3.47	V
		2.37	2.50	2.62	V
		1.71	1.80	1.89	V
Status Pin Supply Voltage	$V_{DDS}$	3.14	3.30	3.47	V
		1.71	1.80	1.89	V

**Note:**

1. All minimum and maximum specifications are guaranteed and apply across the recommended operating conditions. Typical values apply at nominal supply voltages and an operating temperature of 25 °C unless otherwise noted.

**Table 5.2. DC Characteristics**

( $V_{DD} = 1.8\text{ V} \pm 5\%$ ,  $V_{DDA} = 3.3\text{ V} \pm 5\%$ ,  $V_{DDIO}/V_{DDS} = 3.3\text{ V} \pm 5\%$ ,  $1.8\text{ V} \pm 5\%$ ,  $V_{DDO} = 1.8\text{ V} \pm 5\%$ ,  $2.5\text{ V} \pm 5\%$ , or  $3.3\text{ V} \pm 5\%$ ,  $T_A = -40$  to  $85\text{ }^\circ\text{C}$ )

Parameter	Symbol	Test Condition	Min	Typ	Max	Unit
Core Supply Current <sup>1, 2, 3</sup>	$I_{DD}$	Si5397, 4 DSPLLs	—	320	520	mA
		S5397, 1 DSPLL	—	200	360	mA
		Si5396, 2 DSPLLs	—	180	290	mA
	$I_{DDA}$	Si5397, 4 DSPLLs	—	155	195	mA
		Si5397, 1 DSPLL	—	125	140	mA
		Si5396, 2 DSPLLs	—	120	150	mA
Output Buffer Supply Current	$I_{DDO}$	2.5 V LVPECL Output <sup>3</sup>	—	22	26	mA
		2.5 V LVDS Output <sup>3</sup>	—	15	18	mA
		3.3 V LVCMOS Output <sup>4</sup>	—	22	30	mA
		2.5 V LVCMOS Output <sup>4</sup>	—	18	23	mA
		1.8 V LVCMOS Output <sup>4</sup>	—	12	16	mA
Total Power Dissipation <sup>5</sup>	$P_d$	Si5397, 4 DSPLLs <sup>1</sup>	—	1400	1950	mW
		Si5397, 2 DSPLLs <sup>1</sup>	—	1100	1550	mW
		Si5396, 2 DSPLLs <sup>2</sup>	—	870	1200	mW

**Notes:**

- Si5397 test configuration: 7×2.5 V LVDS outputs enabled @156.25 MHz. Excludes power in termination resistors.
- Si5396 test configuration: 4×2.5 V LVDS outputs enabled @ 156.25 MHz. Excludes power in termination resistors.
- Differential outputs terminated into an ac-coupled 100 Ω load.

**Differential Output Test Configuration**

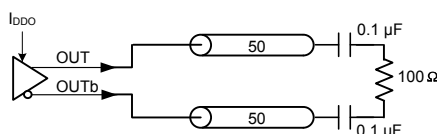

- LVCMOS outputs measured into a 5-inch 50 Ω PCB trace with 5 pF load. The LVCMOS outputs were set to `OUTx_CMOS_DRV = 3`, which is the strongest driver setting. Refer to the [Si5397/96 Family Reference Manual](#) for more details on register settings.

**LVCMOS Output Test Configuration**

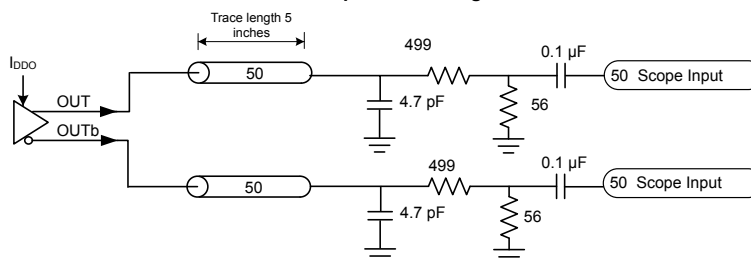

- Detailed power consumption for any configuration can be estimated using [ClockBuilder Pro](#) when an evaluation board (EVB) is not available. All EVBs support detailed current measurements for any configuration.

**Table 5.3. Input Clock Specifications**
 $V_{DD} = 1.8\text{ V} \pm 5\%$ ,  $V_{DDA} = 3.3\text{ V} \pm 5\%$ ,  $T_A = -40\text{ to }85\text{ }^\circ\text{C}$ 

Parameter	Symbol	Test Condition	Min	Typ	Max	Unit
<b>Standard Differential or Single-Ended - AC Coupled Input Buffer (IN0/IN0b, IN1/IN1b, IN2/IN2b, IN3/IN3b)</b>						
Input Frequency Range	$f_{IN}$	Differential	0.008	—	750	MHz
		All Single-ended signals (including LVCMOS)	0.008	—	250	MHz
Voltage Swing <sup>1</sup>	$V_{IN}$	Differential ac-coupled $f_{IN} < 250\text{ MHz}$	100	—	1800	mVpp_se
		Differential ac-coupled $250\text{ MHz} < f_{IN} < 750\text{ MHz}$	225	—	1800	mVpp_se
		Single-ended ac-coupled $f_{IN} < 250\text{ MHz}$	100	—	3600	mVpp_se
Slew Rate <sup>2,3</sup>	SR		400	—	—	V/ $\mu$ s
Duty Cycle	DC		40	—	60	%
Input Capacitance	$C_{IN}$		—	2.4	—	pF
Input Resistance Differential	$R_{IN\_DIFF}$		—	16	—	k $\Omega$
Input Resistance Single-ended	$R_{IN\_SE}$		—	8	—	k $\Omega$
<b>LVCMOS / Pulsed CMOS DC-Coupled Input Buffer (IN0, IN1, IN2, IN3)<sup>4</sup></b>						
Input Frequency	$f_{IN\_CMOS}$	Standard CMOS & Non-standard CMOS	0.008	—	250	MHz
		Pulsed CMOS	0.008	—	1	MHz
Input Voltage <sup>5</sup>	$V_{IL}$	Standard CMOS	—	—	0.5	V
		Non-standard CMOS & Pulsed CMOS	—	—	0.4	V
	$V_{IH}$	Standard CMOS	1.3	—	—	V
		Non-standard CMOS & Pulsed CMOS	0.8	—	—	V
Slew Rate <sup>2,3</sup>	SR		400	—	—	V/ $\mu$ s
Duty Cycle	DC	Standard CMOS & Non-standard CMOS	40	—	60	%
		Pulsed CMOS	5	—	95	
Minimum Pulse Width	PW	Standard CMOS & Non-standard CMOS (250 MHz @ 40% Duty Cycle)	1.6	—	—	ns
		Pulsed CMOS (1 MHz @ 40% Duty Cycle)	50	—	—	

Parameter	Symbol	Test Condition	Min	Typ	Max	Unit
Input Resistance	$R_{IN}$		—	8	—	$k\Omega$
<b>REFCLK (Applied to XA/XB)</b>						
REFCLK Frequency	$f_{IN\_REF}$	Full operating range. Jitter performance may be reduced.	24.97	—	54.06	MHz
		Range for best jitter.	48	—	54	MHz
Input Voltage Swing	$V_{IN\_DIFF}$		365	—	2500	mVpp_diff
	$V_{IN\_SE}$		365	—	2000	mVpp_se
Slew rate <sup>2,3</sup>	SR		400	—	—	V/ $\mu$ s
Input Duty Cycle	DC		40	—	60	%

**Notes:**

- Voltage swing is specified as single-ended mVpp.

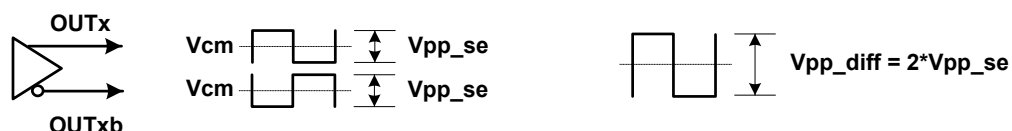

- Recommended for specified jitter performance. Slew rate can go lower, but jitter performance could degrade if the minimum slew rate specification is not met (See the [Si5397/96 Family Reference Manual](#)).

3. Rise and fall times can be estimated using the following simplified equation:  $t_r/t_f_{80-20} = ((0.8 - 0.2) \times V_{IN\_Vpp\_se}) / SR$ .

- Standard, Non-standard and Pulsed CMOS refer to different formats of CMOS each with a voltage swing of 1.8V, 2.5V or 3.3V +/-5%.

- Standard CMOS refers to the industry standard LVCMOS signal.
- Non-standard CMOS refers to a signal that has been attenuated/level-shifted in order to comply with the specified non-standard VIL and VIH specifications.
- Pulsed CMOS refers to a signal that has been attenuated/level-shifted and has a low/high duty cycle and must be dc coupled. A typical application example is a low-frequency video frame sync pulse.

Refer to the [Si5397/96 Reference Manual](#) for the recommended connections/termination for the different modes.

- CMOS signals that exceed 3.3 V + 5% can be used as inputs as long as a resistive attenuation network is used to guarantee that the input voltage at the pin does not violate the device's input ratings. Please refer to the [Si5397/96 Reference Manual](#) for the recommended connections/termination for this mode.



**Table 5.4. Serial and Control Input Pin Specifications**
 $V_{DD} = 1.8\text{ V} \pm 5\%$ ,  $V_{DDA} = 3.3\text{ V} \pm 5\%$ ,  $V_{DDIO}/V_{DDS} = 3.3\text{ V} \pm 5\%$ ,  $1.8\text{ V} \pm 5\%$ ,  $T_A = -40\text{ to }85\text{ }^\circ\text{C}$ 

Parameter	Symbol	Test Condition	Min	Typ	Max	Unit
<b>Si5397 Serial and Control Input Pins (I2C_SEL, RSTb, OE0b, A1/SDO, SCLK, A0/CSb, FINC, A0/CSb, SDA/SDIO, DSPLL_SEL[1:0])</b>						
Input Voltage	$V_{IL}$		—	—	$0.3 \times V_{DDIO}^1$	V
	$V_{IH}$		$0.7 \times V_{DDIO}^1$	—	—	V
Input Capacitance	$C_{IN}$		—	2	—	pF
Input Resistance	$R_L$		—	20	—	k $\Omega$
Minimum Pulse Width	PW	RSTb, FINC	100	—	—	ns
Update Rate	$F_{UR}$	FINC	—	—	1	MHz
<b>Si5397 Control Input Pins (FDEC, OE1b)</b>						
Input Voltage	$V_{IL}$		—	—	$0.3 \times V_{DDS}$	V
	$V_{IH}$		$0.7 \times V_{DDS}$	—	—	V
Input Capacitance	$C_{IN}$		—	2	—	pF
Minimum Pulse Width	PW	FDEC	100	—	—	ns
Update Rate	$F_{UR}$	FDEC	—	—	1	MHz
<b>Si5396 Serial and Control Input Pins (I2C_SEL, RSTb, OE0b, OE1b, A1/SDO, SCLK, A0/CSb, SDA/SDIO)</b>						
Input Voltage	$V_{IL}$		—	—	$0.3 \times V_{DDIO}^1$	V
	$V_{IH}$		$0.7 \times V_{DDIO}^1$	—	—	V
Input Capacitance	$C_{IN}$		—	2	—	pF
Input Resistance	$R_L$		—	20	—	k $\Omega$
Minimum Pulse Width	PW	RSTb	100	—	—	ns
<b>Note:</b>						
1. $V_{DDIO}$ is determined by the IO_VDD_SEL bit. It is selectable as $V_{DDA}$ or $V_{DD}$ .						

**Table 5.5. Differential Clock Output Specifications**(V<sub>DD</sub> = 1.8 V ±5%, V<sub>DDA</sub> = 3.3V ±5%, V<sub>DDO</sub> = 1.8 V ±5%, 2.5 V ±5%, or 3.3 V ±5%, T<sub>A</sub> = -40 to 85 °C)

Parameter	Symbol	Test Condition		Min	Typ	Max	Unit
Output Frequency	f <sub>OUT</sub>			0.0001	—	720	MHz
Duty Cycle	DC	f <sub>OUT</sub> < 400 MHz		48	—	52	%
		400 MHz < f <sub>OUT</sub> < 720 MHz		45	—	55	%
Output Voltage Amplitude <sup>1</sup>	V <sub>OUT</sub>	V <sub>DDO</sub> = 3.3 V, 2.5 V, or 1.8 V	LVDS	350	450	530	mVpp <sub>se</sub>
		V <sub>DDO</sub> = 3.3 V, 2.5 V	LVPECL	630	750	950	mVpp <sub>se</sub>
Common Mode Voltage <sup>1,2</sup>	V <sub>CM</sub>	V <sub>DDO</sub> = 3.3 V	LVDS	1.10	1.20	1.30	V
			LVPECL	1.90	2.00	2.10	V
		V <sub>DDO</sub> = 2.5 V	LVPECL, LVDS	1.10	1.20	1.30	V
			sub-LVDS	0.80	0.90	1.00	V
Output-to-Output Skew (Same DSPLL, Different Outputs)	T <sub>SKS</sub>	f <sub>OUT</sub> = 720 MHz (LVDS differential)		—	0	75	ps
OUT-OUTb Skew (Same Output)	T <sub>SK_OUT</sub>	Measured from positive to negative output pins		—	0	50	ps
Rise and Fall Times	t <sub>r</sub> /t <sub>f</sub>	f <sub>OUT</sub> > 100 MHz (20% to 80%)		—	100	200	ps
Differential Output Impedance	Z <sub>O</sub>			—	100	—	Ω
Power Supply Noise Rejection <sup>2</sup>	PSRR	10 kHz sinusoidal noise		—	-101	—	dBc
		100 kHz sinusoidal noise		—	-96	—	dBc
		500 kHz sinusoidal noise		—	-99	—	dBc
		1 MHz sinusoidal noise		—	-97	—	dBc
Output-output Crosstalk <sup>3</sup>	XTALK	Si5397		—	-72	—	dB
		Si5396		—	-88	—	dB

Parameter	Symbol	Test Condition	Min	Typ	Max	Unit
-----------	--------	----------------	-----	-----	-----	------

**Notes:**

- Output amplitude and common-mode settings are programmable through register settings and can be stored in NVM. Each output driver can be programmed independently. Note that the maximum LVDS single-ended amplitude can be up to 110 mV higher than the TIA/EIA-644 maximum. Refer to the [Si5397/96 Reference Manual](#) for more suggested output settings. Not all combinations of voltage amplitude and common mode voltages settings are possible.

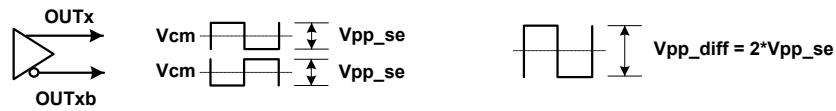
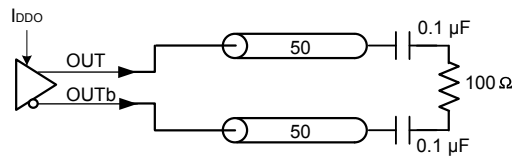
**Differential Output Test Configuration**

- Measured for 156.25 MHz carrier frequency. 100 mVpp sinewave noise added to V<sub>DDO</sub> = 3.3 V and noise spur amplitude measured.
- Measured across two adjacent outputs, both in LVDS mode, with the victim running at 155.52 MHz and the aggressor at 156.25 MHz. Refer to "AN862: Optimizing Si534x Jitter Performance in Next Generation Internet Infrastructure Systems" for guidance on crosstalk optimization. Note that all active outputs must be terminated when measuring crosstalk.

**Table 5.6. LVCMOS Clock Output Specifications**

 ( $V_{DD} = 1.8\text{ V} \pm 5\%$ ,  $V_{DDA} = 3.3\text{ V} \pm 5\%$ ,  $V_{DDO} = 1.8\text{ V} \pm 5\%$ ,  $2.5\text{ V} \pm 5\%$ , or  $3.3\text{ V} \pm 5\%$ ,  $T_A = -40\text{ to }85\text{ }^\circ\text{C}$ )

Parameter	Symbol	Test Condition	Min	Typ	Max	Unit	
Output Frequency	$f_{OUT}$		0.0001	—	250	MHz	
Duty Cycle	DC	$f_{OUT} < 100\text{ MHz}$	48	—	52	%	
		$100\text{ MHz} < f_{OUT} < 250\text{ MHz}$	44	—	56		
Output Voltage High <sup>1,2,3</sup>	$V_{OH}$	$V_{DDO} = 3.3\text{ V}$					
		OUTx_CMOS_DRV=1	$I_{OH} = -10\text{ mA}$	$V_{DDO} \times 0.85$	—	—	V
		OUTx_CMOS_DRV=2	$I_{OH} = -12\text{ mA}$		—	—	
		OUTx_CMOS_DRV=3	$I_{OH} = -17\text{ mA}$		—	—	
		$V_{DDO} = 2.5\text{ V}$					
		OUTx_CMOS_DRV=1	$I_{OH} = -6\text{ mA}$	$V_{DDO} \times 0.85$	—	—	V
		OUTx_CMOS_DRV=2	$I_{OH} = -8\text{ mA}$		—	—	
		OUTx_CMOS_DRV=3	$I_{OH} = -11\text{ mA}$		—	—	
		$V_{DDO} = 1.8\text{ V}$					
		OUTx_CMOS_DRV=2	$I_{OH} = -4\text{ mA}$	$V_{DDO} \times 0.85$	—	—	V
OUTx_CMOS_DRV=3	$I_{OH} = -5\text{ mA}$	—	—				
Output Voltage Low <sup>1,2,3</sup>	$V_{OL}$	$V_{DDO} = 3.3\text{ V}$					
		OUTx_CMOS_DRV=1	$I_{OL} = 10\text{ mA}$	—	—	$V_{DDO} \times 0.15$	V
		OUTx_CMOS_DRV=2	$I_{OL} = 12\text{ mA}$	—	—		
		OUTx_CMOS_DRV=3	$I_{OL} = 17\text{ mA}$	—	—		
		$V_{DDO} = 2.5\text{ V}$					
		OUTx_CMOS_DRV=1	$I_{OL} = 6\text{ mA}$	—	—	$V_{DDO} \times 0.15$	V
		OUTx_CMOS_DRV=2	$I_{OL} = 8\text{ mA}$	—	—		
		OUTx_CMOS_DRV=3	$I_{OL} = 11\text{ mA}$	—	—		
		$V_{DDO} = 1.8\text{ V}$					
		OUTx_CMOS_DRV=2	$I_{OL} = 4\text{ mA}$	—	—	$V_{DDO} \times 0.15$	V
OUTx_CMOS_DRV=3	$I_{OL} = 5\text{ mA}$	—	—	$V_{DDO} \times 0.15$	V		
Rise and Fall Times <sup>3</sup>	$t_r/t_f$	(20% to 80%)	$V_{DDO} = 3.3\text{ V}$	—	400	600	ps
			$V_{DDO} = 2.5\text{ V}$	—	450	600	ps
			$V_{DDO} = 1.8\text{ V}$	—	550	750	ps

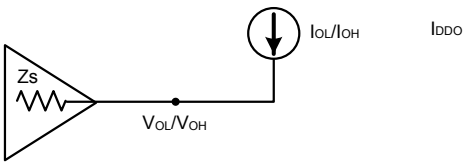
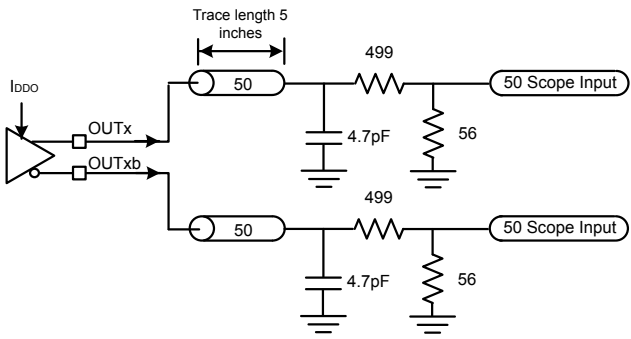
Parameter	Symbol	Test Condition	Min	Typ	Max	Unit
<p>1. Driver strength is a register programmable setting and stored in NVM. Options are OUTx_CMOS_DRV = 1, 2, 3. Refer to the <a href="#">Si5397/96 Family Reference Manual</a> for more details on register settings.</p> <p>2. I<sub>OL</sub>/I<sub>OH</sub> is measured at V<sub>OL</sub>/V<sub>OH</sub> as shown in the DC test configuration.</p> <p style="text-align: center;"><b>DC Test Configuration</b></p>  <p>3. A series termination resistor (Rs) is recommended to help match the source impedance to a 50 Ω PCB trace. A 4.7 pF capacitive load is assumed. The LVCMOS outputs were set to OUTx_CMOS_DRV = 3, at 156.25 MHz.</p> <p style="text-align: center;"><b>LVCMOS Output Test Configuration</b></p> 						

**Table 5.7. Output Serial and Status Pin Specifications**

(V<sub>DD</sub> = 1.8 V ±5%, V<sub>DDA</sub> = 3.3 V ±5%, V<sub>DDIO</sub>/V<sub>DDS</sub> = 3.3 V ±5%, 1.8 V ±5%, T<sub>A</sub> = -40 to 85 °C)

Parameter	Symbol	Test Condition	Min	Typ	Max	Unit
<b>Si5397 Serial and Status Output Pins (LOL_Ab, LOL_Bb, LOL_Cb, LOL_Db, INTRb, LOS_XAXBb, SDA/SDIO<sup>1</sup>, A1/SDO)</b>						
Output Voltage	V <sub>OH</sub>	I <sub>OH</sub> = -2 mA	V <sub>DDIO</sub> <sup>2</sup> x 0.85	—	—	V
	V <sub>OL</sub>	I <sub>OL</sub> = 2 mA	—	—	V <sub>DDIO</sub> <sup>2</sup> x 0.15	V
<b>Si5396 Status Output Pins (INTRb, LOS_XAXBb, SDA/SDIO<sup>1</sup>, A1/SDO)</b>						
Output Voltage	V <sub>OH</sub>	I <sub>OH</sub> = -2 mA	V <sub>DDIO</sub> <sup>2</sup> x 0.85	—	—	V
	V <sub>OL</sub>	I <sub>OL</sub> = 2 mA	—	—	V <sub>DDIO</sub> <sup>2</sup> x 0.15	V
<b>Si5396 Status Output Pins (LOL_Ab, LOL_Bb)</b>						
Output Voltage	V <sub>OH</sub>	I <sub>OH</sub> = -2 mA	V <sub>DDS</sub> x 0.85	—	—	V
	V <sub>OL</sub>	I <sub>OL</sub> = 2 mA	—	—	V <sub>DDS</sub> x 0.15	V

**Notes:**

- The V<sub>OH</sub> specification does not apply to the open-drain SDA/SDIO output when the serial interface is in I<sup>2</sup>C mode or is unused with I2C\_SEL pulled high. V<sub>OL</sub> remains valid in all cases.
- V<sub>DDIO</sub> is determined by the IO\_VDD\_SEL bit. It is selectable as V<sub>DDA</sub> or V<sub>DD</sub>. Users normally select this option in the [ClockBuilder Pro](#) GUI. Alternatively, refer to the [Si5397/96 Family Reference Manual](#) for more details on register settings.

**Table 5.8. Performance Characteristics**
 $V_{DD} = 1.8\text{ V} \pm 5\%$ ,  $V_{DDA} = 3.3\text{ V} \pm 5\%$ ,  $V_{DDO} = 1.8\text{ V} \pm 5\%$ ,  $2.5\text{ V} \pm 5\%$ , or  $3.3\text{ V} \pm 5\%$ ,  $T_A = -40\text{ to }85\text{ }^\circ\text{C}$ 

Parameter	Symbol	Test Condition	Min	Typ	Max	Unit	
PLL Loop Bandwidth Programming Range <sup>1</sup>	$f_{BW}$		0.1	—	4000	Hz	
Initial Start-Up Time	$t_{START}$	Time from power-up to when the device generates free-running clocks	—	30	45	ms	
PLL Lock Time <sup>2</sup>	$t_{ACQ}$	With Fastlock enabled, $f_{IN} = 19.44\text{ MHz}$	—	280	300	ms	
POR to Serial Interface Ready <sup>3</sup>	$t_{RDY}$		—	—	15	ms	
Maximum Phase Transient During a Hitless Switch <sup>4</sup>	$t_{SWITCH}$	Single automatic/manual switch between two 8 kHz inputs, DSPLL BW = 40 Hz	—	—	0.8	ns	
		Single automatic/manual switch between two 2 MHz inputs, DSPLL BW = 400 Hz	—	—	0.3	ns	
							ns
							ns
Input-to-Output Delay Variation <sup>5</sup>	$t_{IODELAY}$	$f_{IN} = f_{OUT} = 2\text{ MHz}$ DSPLL BW = 4 kHz	—	—	0.55	ns	
		$f_{IN} = f_{OUT} = 62\text{ kHz}$ DSPLL BW = 4 kHz	—	—	0.75	ns	
		$f_{IN} = f_{OUT} = 8\text{ kHz}$ DSPLL BW = 4 kHz	—	—	3.00	ns	
Jitter Peaking	$J_{PK}$	Measured with a frequency plan running a 25 MHz input, 25 MHz output, and a loop bandwidth of 4 Hz	—	—	0.1	dB	
Jitter Tolerance	$J_{TOL}$	Compliant with G.8262 Options 1 and 2 for 1G, 10G or 25G Synchronous Ethernet Jitter Modulation Frequency = 10 Hz	—	3180	—	UI pk-pk	
Pull-in Range	$\omega_P$		—	500	—	ppm	
RMS Phase Jitter <sup>6</sup>	$J_{GEN}$	12 kHz to 20 MHz	—	95	140	fs	

**Notes:**

- Actual loop bandwidth might be lower; please refer to CBPro for actual value on your frequency plan.
- Lock Time can vary significantly depending on several parameters, such as bandwidths, LOL thresholds, etc. For this case, lock-time was measured with nominal bandwidth set to 100 Hz, fastlock bandwidth set to 1 kHz, LOL set/clear thresholds of 6/0.6 ppm respectively, using IN0 as clock reference by removing the reference and enabling it again, then measuring the delta time between the first rising edge of the clock reference and the LOL indicator deassertion.
- Measured as time from valid VDD/VDDA rails (90% of their value) to when the serial interface is ready to respond to commands.
- Higher input frequencies will typically result in higher Fpfd frequencies, which, in turn, will result in better hitless switching performance. It is recommended to use higher input frequencies for the best hitless switching performance.
- Delay is dependent on frequency configuration. Using  $f_{PFD} < 128\text{ kHz}$  will result in higher delay values. Input clock rise time must be  $< 200\text{ ps}$ .
- Test conditions:  $f_{IN} = 19.44\text{ MHz}$ ,  $f_{OUT} = 156.25\text{ MHz}$  LVPECL, loop bandwidth = 100 Hz,  $f_{XTAL} = 48\text{ MHz}$ .

**Table 5.9. I<sup>2</sup>C Timing Specifications (SCL, SDA)**V<sub>DD</sub>= 1.8 V ±5%, V<sub>DDA</sub>= 3.3 V ±5%, V<sub>DDS</sub>/V<sub>DDIO</sub>= 3.3 V ±5%, 1.8 V ±5%, T<sub>A</sub>= -40 to 85 °C

Parameter	Symbol	Test Condition	Standard Mode 100 kbps		Fast Mode 400 kbps		Unit
			Min	Max	Min	Max	
SCL Clock Frequency	f <sub>SCL</sub>		—	100	—	400	kHz
SMBus Timeout	—		25	35	25	35	ms
Hold time (Repeated) START condition	t <sub>HD:STA</sub>		4.0	—	0.6	—	μs
Low Period of the SCL Clock	t <sub>LOW</sub>		4.7	—	1.3	—	μs
HIGH Period of the SCL Clock	t <sub>HIGH</sub>		4.0	—	0.6	—	μs
Setup Time for a Repeated START Condition	t <sub>SU:STA</sub>		4.7	—	0.6	—	μs
Data Hold Time	t <sub>HD:DAT</sub>		100	—	100	—	ns
Data Setup Time	t <sub>SU:DAT</sub>		250	—	100	—	ns
Rise Time of both SDA and SCL Signals	t <sub>r</sub>		—	1000	20	300	ns
Fall Time of both SDA and SCL Signals	t <sub>f</sub>		—	300	—	300	ns
Setup Time for STOP Condi- tion	t <sub>SU:STO</sub>		4.0	—	0.6	—	μs
Bus Free Time between a STOP and START Condition	t <sub>BUF</sub>		4.7	—	1.3	—	μs
Data Valid Time	t <sub>VD:DAT</sub>		—	3.45	—	0.9	μs
Data Valid Acknowledge Time	t <sub>VD:ACK</sub>		—	3.45	—	0.9	μs

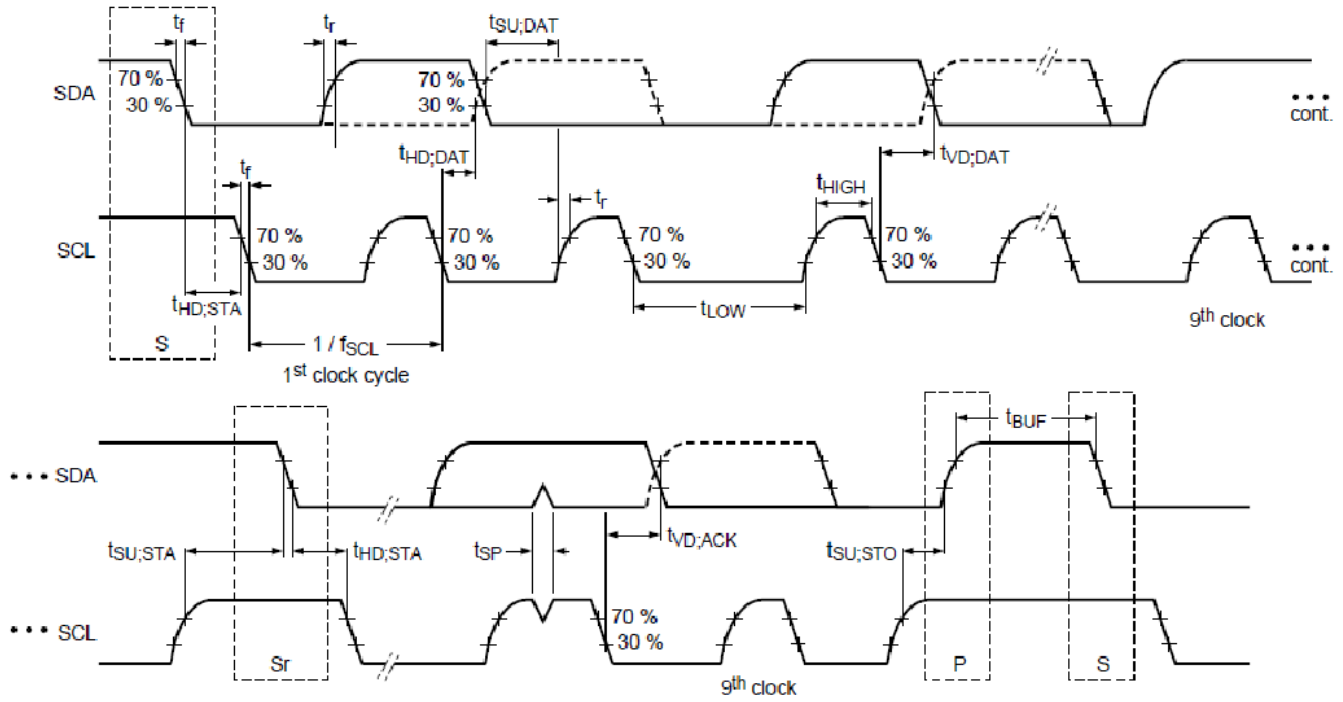

Figure 5.1. I<sup>2</sup>C Serial Port Timing Standard and Fast Modes

Table 5.10. SPI Timing Specifications (4-Wire)

(V<sub>DD</sub> = 1.8 V ±5%, V<sub>DDA</sub> = 3.3 V ±5%, V<sub>DDIO</sub> = 3.3 V ±5%, 1.8 V ±5%, T<sub>A</sub> = -40 to 85 °C)

Parameter	Symbol	Min	Typ	Max	Unit
SCLK Frequency	f <sub>SPI</sub>	—	—	20	MHz
SCLK Duty Cycle	T <sub>DC</sub>	40	—	60	%
SCLK Period	T <sub>C</sub>	50	—	—	ns
Delay Time, SCLK Fall to SDO Active	T <sub>D1</sub>	—	—	18	ns
Delay Time, SCLK Fall to SDO	T <sub>D2</sub>	—	—	15	ns
Delay Time, CSb Rise to SDO Tri-State	T <sub>D3</sub>	—	—	15	ns
Setup Time, CSb to SCLK	T <sub>SU1</sub>	5	—	—	ns
Hold Time, SCLK Fall to CSb	T <sub>H1</sub>	5	—	—	ns
Setup Time, SDI to SCLK Rise	T <sub>SU2</sub>	5	—	—	ns
Hold Time, SDI to SCLK Rise	T <sub>H2</sub>	5	—	—	ns
Delay Time Between Chip Selects (CSb)	T <sub>CS</sub>	95	—	—	ns



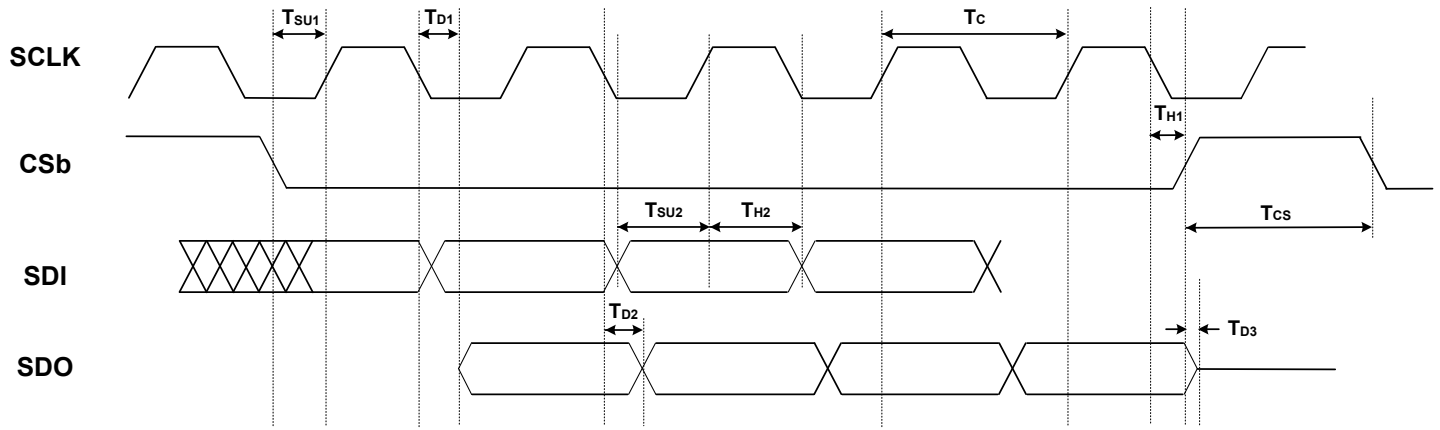

Figure 5.2. 4-Wire SPI Serial Interface Timing

Table 5.11. SPI Timing Specifications (3-Wire)

( $V_{DD} = 1.8\text{ V} \pm 5\%$ ,  $V_{DDA} = 3.3\text{ V} \pm 5\%$ ,  $V_{DDIO} = 3.3\text{ V} \pm 5\%$ ,  $1.8\text{ V} \pm 5\%$ ,  $T_A = -40\text{ to }85\text{ }^\circ\text{C}$ )

Parameter	Symbol	Min	Typ	Max	Units
SCLK Frequency	$f_{\text{SPI}}$	—	—	20	MHz
SCLK Duty Cycle	$T_{\text{DC}}$	40	—	60	%
SCLK Period	$T_{\text{C}}$	50	—	—	ns
Delay Time, SCLK Fall to SDIO Turn-on	$T_{\text{D1}}$	—	12.5	18	ns
Delay Time, SCLK Fall to SDIO Next-bit	$T_{\text{D2}}$	—	10	15	ns
Delay Time, CSb Rise to SDIO Tri-State	$T_{\text{D3}}$	—	10	15	ns
Setup Time, CSb to SCLK	$T_{\text{SU1}}$	5	—	—	ns
Hold Time, SCLK Fall to CSb	$T_{\text{H1}}$	5	—	—	ns
Setup Time, SDI to SCLK Rise	$T_{\text{SU2}}$	5	—	—	ns
Hold Time, SDI to SCLK Rise	$T_{\text{H2}}$	5	—	—	ns
Delay Time Between Chip Selects (CSb)	$T_{\text{CS}}$	95	—	—	ns

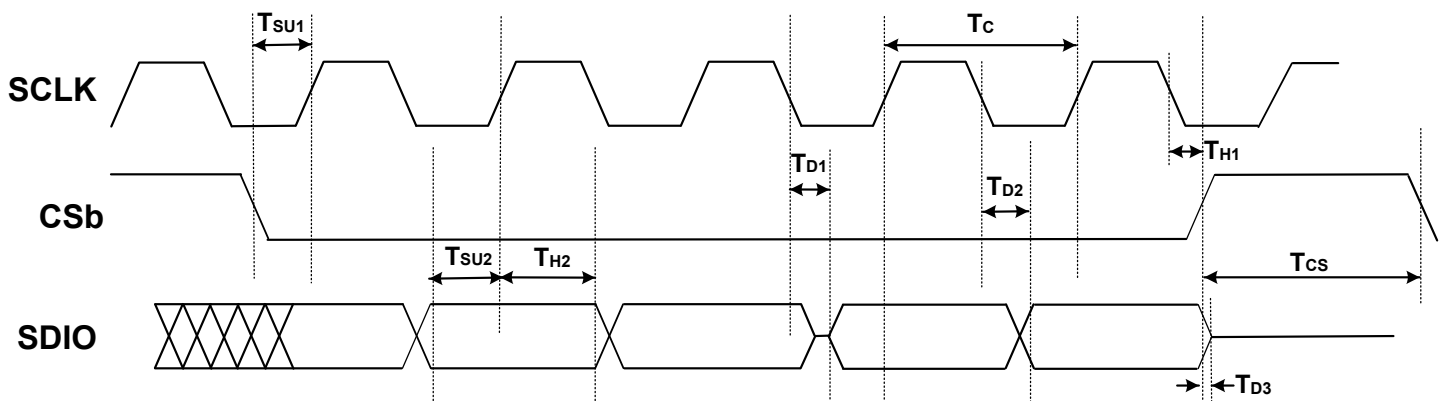

Figure 5.3. 3-Wire SPI Serial Interface Timing

Table 5.12. External Crystal Specifications for Grades A/B/C/D<sup>1</sup>

Parameter	Symbol	Test Condition	Min	Typ	Max	Unit
Crystal Frequency Range	$f_{XTAL(A/B/C/D)}$	Full operating range. Jitter performance may be reduced.	24.97	—	54.06	MHz
		Range for best jitter.	48	—	54	MHz
Load Capacitance	$C_L$		—	8	—	pF
Crystal Drive Level	$d_L$		—	—	200	$\mu$ W
Equivalent Series Resistance Shunt Capacitance	$r_{ESR}$ $C_O$	Refer to the <a href="#">Si5397/96 Family Reference Manual</a> to determine ESR and shunt capacitance.				
<b>Notes:</b>						
1. Refer to the Si534x/8x/9x Recommended Crystal, TCXO and OCXOs Reference Manual for recommended 48 to 54 MHz crystals.						

Table 5.13. Internal Reference Specifications for Grade J/K/L/M<sup>1, 2</sup>

Parameter	Symbol	Test Condition	Min	Typ	Max	Unit
Initial Accuracy	—		-8	—	+8	ppm
Frequency Characteristics across Temperature	—	Inclusive of temperature range of -40 to 125 °C, aging at 115 °C and reflow	-88	—	+88	ppm
Activity Dip	—	Frequency Perturbations	-2	—	+2	ppm
Overall Accuracy	—	Inclusive of Initial Accuracy, Frequency Characteristics Across Temperature and Activity Dips (all items listed above)	-98	—	+98	ppm
<b>Note:</b>						
1. These devices with integrated reference have been tuned with an internal 48 MHz reference to deliver optimum performance. It is important to note that connecting an external reference to a device that already has an integrated reference is not allowed. Doing so could lead to internal damage to the circuits.						
2. Clocks that feature the integrated crystal may require a slightly longer settling time compared to the external crystal device. See the Reference Manual for more details.						

Table 5.14. Thermal Characteristics 44-QFN and 44-LGA (Si5396)

Parameter	Symbol	Test Condition	44-QFN	44-LGA	Unit
Thermal Resistance Junction to Ambient	$\theta_{JA}$	Still Air <sup>1, 2</sup>	22.3	25.49	°C/W
		Air Flow 1 m/s <sup>1, 2</sup>	19.4	22.14	°C/W
		Air Flow 2 m/s <sup>1, 2</sup>	18.4	21.13	°C/W
Thermal Resistance Junction to Case	$\theta_{JC}$		10.9	9.87	°C/W
Thermal Resistance Junction to Board	$\theta_{JB}$		9.3	9.52	°C/W
	$\Psi_{JB}$		9.2	9.58	°C/W
Thermal Resistance Junction to Top Center	$\Psi_{JT}$		0.23	0.81	°C/W

**Note:**

- 44-QFN: Based on PCB Dimension: 3" x 4.5" PCB Thickness: 1.6 mm, PCB Land/Via: 36, Number of Cu Layers: 4.
- 44-LGA: Based on 4 layer PCB with dimension 4" x 4.5", PCB Thickness of 1.6 mm, per JEDEC. PCB Center Land with 16 Via to top internal plane of PCB.

Table 5.15. Thermal Characteristics 64-QFN and 64-LGA (Si5397)

Parameter	Symbol	Test Condition	64-QFN	64-LGA	Unit
Thermal Resistance Junction to Ambient	$\theta_{JA}$	Still Air <sup>1, 2</sup>	22	22.3	°C/W
		Air Flow 1 m/s <sup>1, 2</sup>	19.4	19.4	°C/W
		Air Flow 2 m/s <sup>1, 2</sup>	18.3	18.4	°C/W
Thermal Resistance Junction to Case	$\theta_{JC}$		9.5	10.9	°C/W
Thermal Resistance Junction to Board	$\theta_{JB}$		9.4	9.3	°C/W
	$\Psi_{JB}$		9.3	9.2	°C/W
Thermal Resistance Junction to Top Center	$\Psi_{JT}$		0.2	0.23	°C/W

**Note:**

- 64-QFN: Based on PCB Dimension: 3" x 4.5" PCB Thickness: 1.6 mm, PCB Land/Via: 36, Number of Cu Layers: 4.
- 64-LGA: Based on 4 layer PCB with dimension 4" x 4.5", PCB Thickness of 1.6 mm, per JEDEC. PCB Center Land with 16 Via to top internal plane of PCB.

Table 5.16. Absolute Maximum Ratings<sup>1,2,3</sup>

Parameter	Symbol	Test Condition	Value	Unit
DC Supply Voltage	$V_{DD}$		–0.5 to 3.8	V
	$V_{DDA}$		–0.5 to 3.8	V
	$V_{DDO}$		–0.5 to 3.8	V
	$V_{DDS}$		–0.5 to 3.8	V
Input Voltage Range	$V_{I1}$ <sup>4</sup>	IN0 – IN3	–1.0 to 3.8	V
	$V_{I2}$	RSTb, OE0b, OE1b, I2C_SEL, FINC, FDEC, PLL_SEL[1:0] SDA/SDIO, A1/SDO, SCLK, A0/CSb	–0.5 to 3.8	V
	$V_{I3}$	XA/XB	–0.5 to 2.7	V
Latch-up Tolerance	LU		JESD78 Compliant	
ESD Tolerance	HBM	100 pF, 1.5 k $\Omega$	2.0	kV
Max Junction Temperature in Operation	$T_{JCT}$		125	$^{\circ}$ C
Storage Temperature Range	$T_{STG}$		–55 to 150	$^{\circ}$ C
Soldering Temperature (Pb-free profile) <sup>5</sup>	$T_{PEAK}$		260	$^{\circ}$ C
Soldering Temperature Time at $T_{PEAK}$ (Pb-free profile) <sup>5</sup>	$T_P$		20–40	s

**Notes:**

- Permanent device damage may occur if the absolute maximum ratings are exceeded. Functional operation should be restricted to the conditions as specified in the operational sections of this data sheet. Exposure to absolute maximum rating conditions for extended periods may affect device reliability.
- 64-QFN/LGA and 44-QFN/LGA packages are RoHS compliant.
- For detailed packaging information, go to [www.silabs.com/support/quality/pages/RoHSInformation.aspx](http://www.silabs.com/support/quality/pages/RoHSInformation.aspx).
- The minimum voltage at these pins can be as low as –1.0 V when an ac input signal of 10 MHz or greater is applied. See [Table 5.3 Input Clock Specifications on page 23](#) spec for Single-ended ac-coupled  $f_{IN} < 250$  MHz.
- The device is compliant with JEDEC J-STD-020.

## 6. Typical Application Schematic

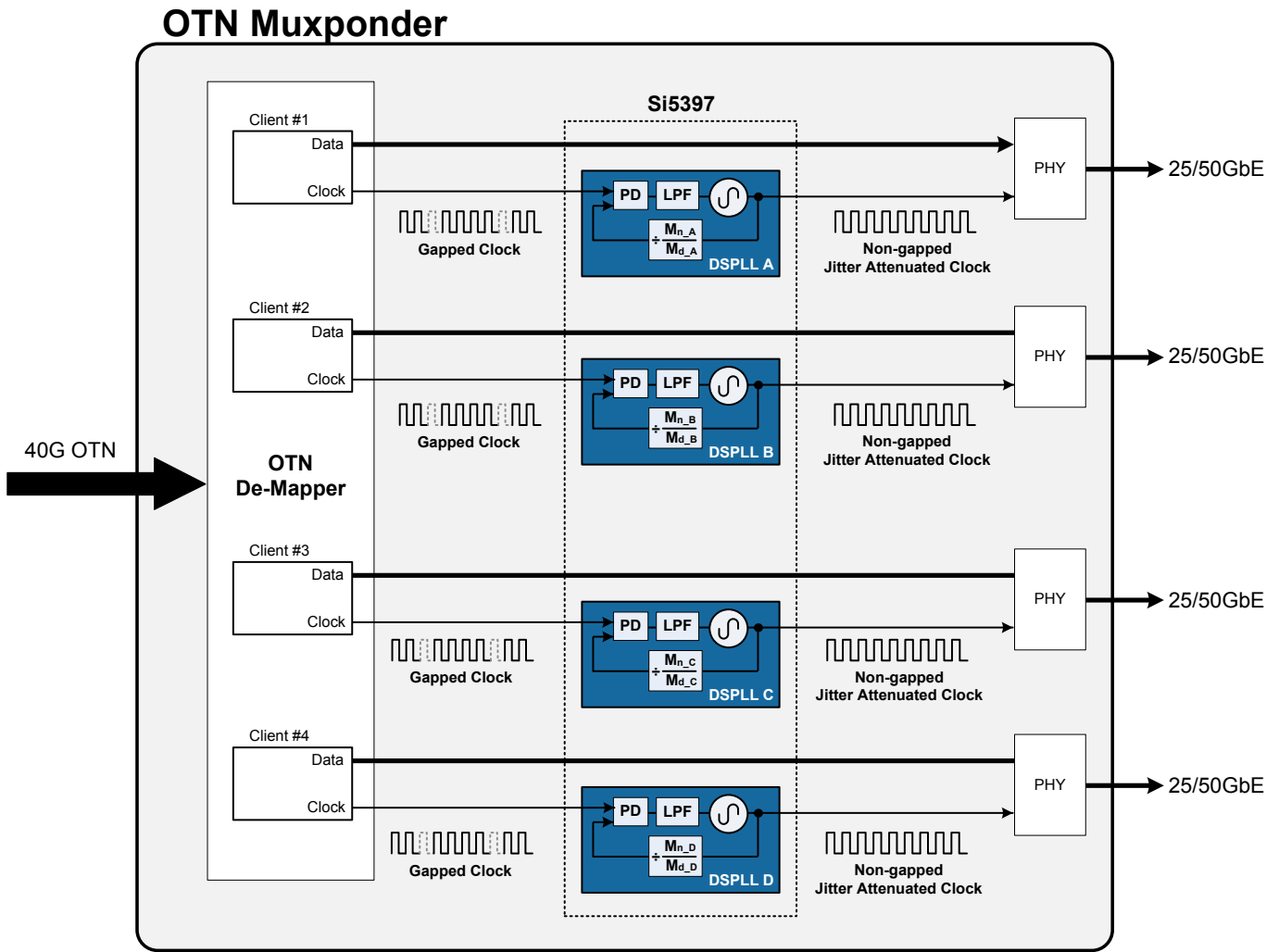

Figure 6.1. Using the Si5397 to Clean Gapped Clocks in an OTN Application

## 7. Detailed Block Diagrams

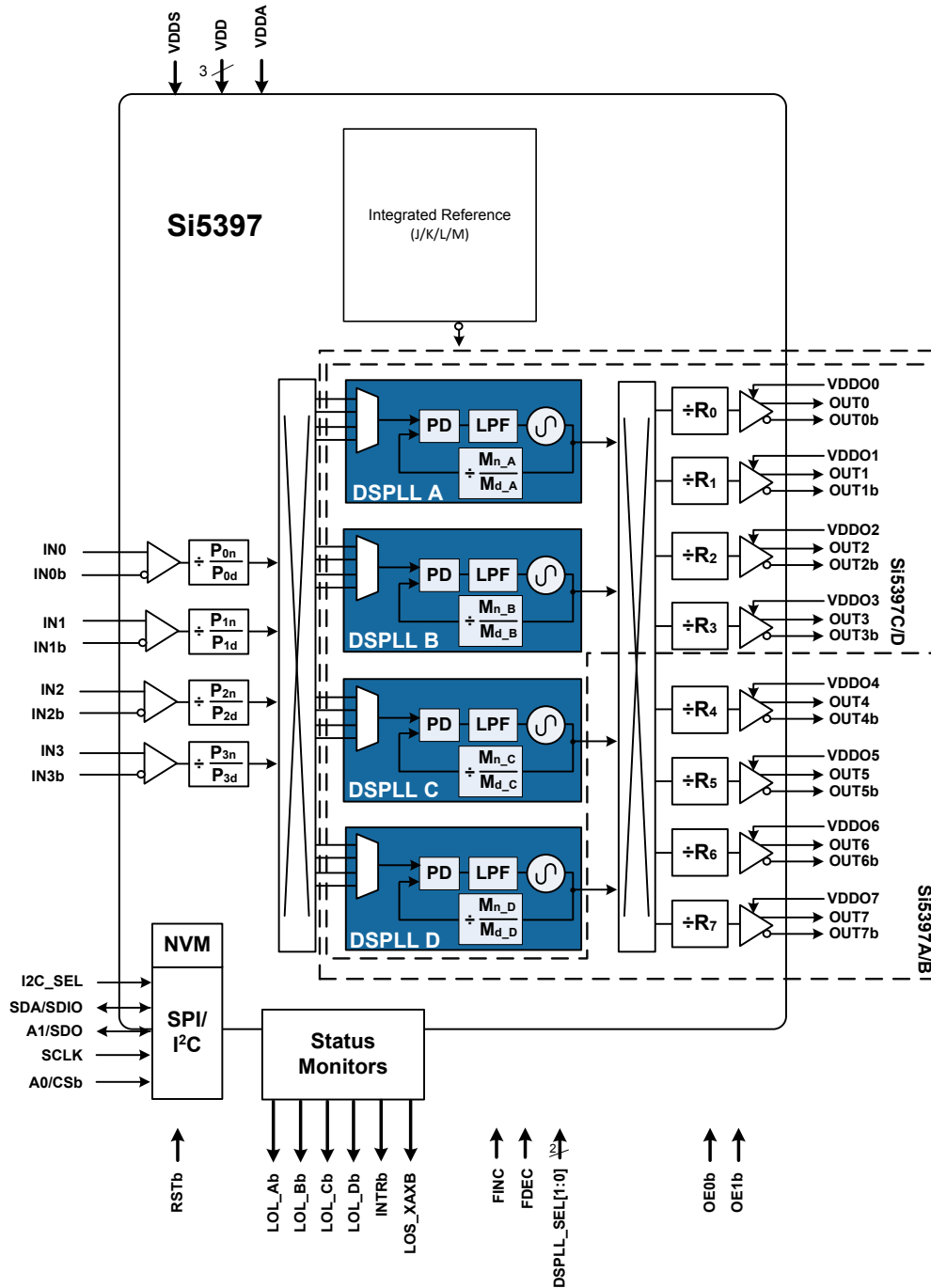

Figure 7.1. Si5397 Block Diagram

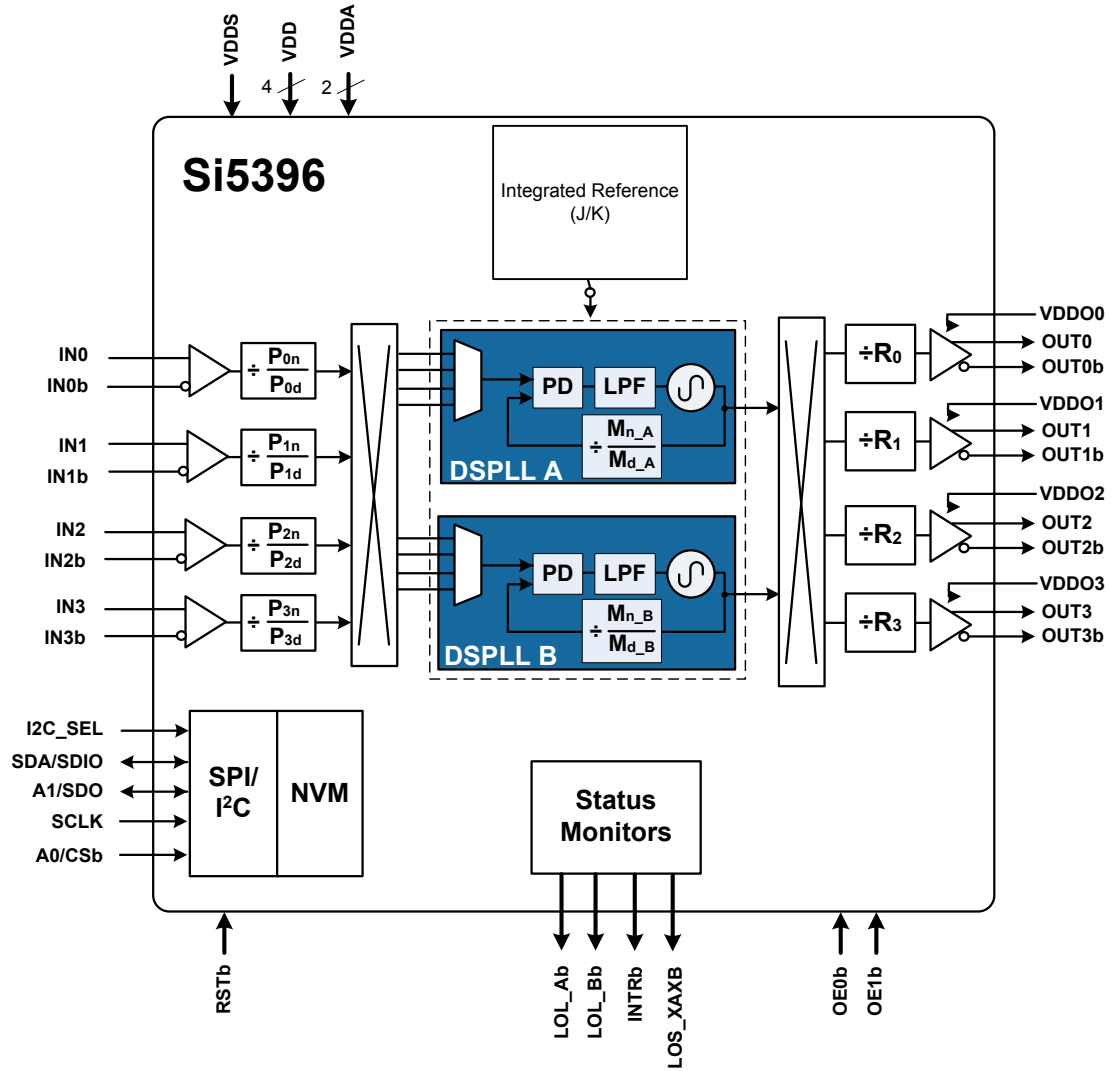

Figure 7.2. Si5396 Block Diagram

### 8. Typical Operating Characteristics (Jitter and Phase Noise)

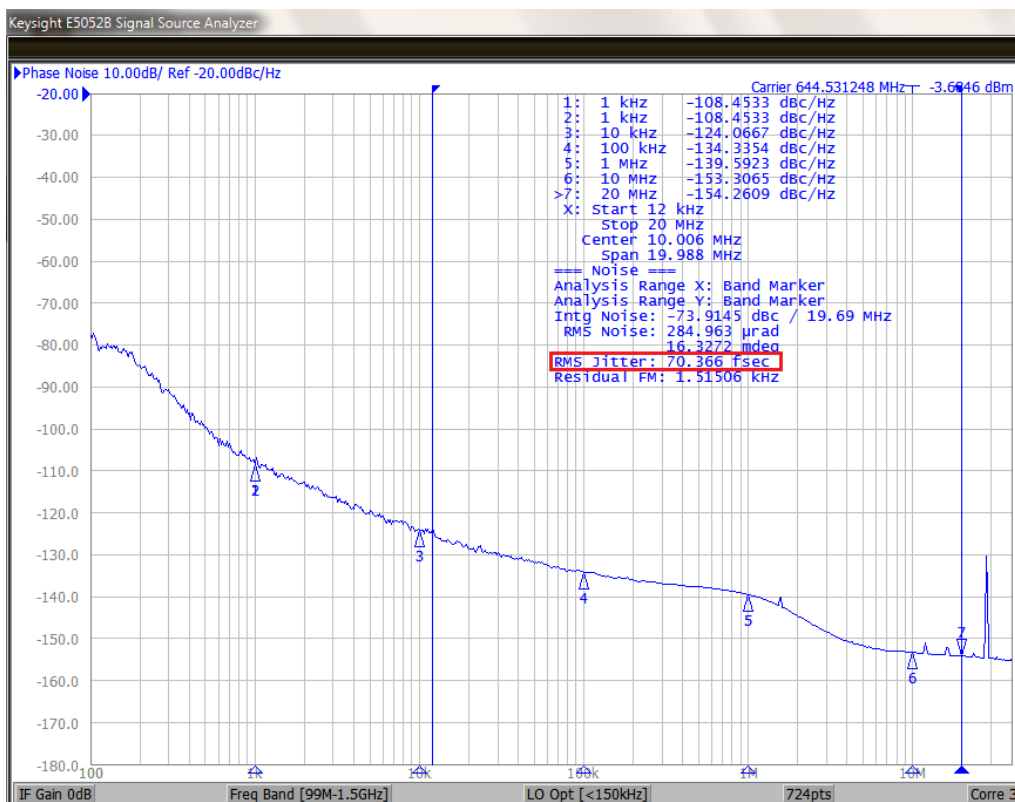

Figure 8.1. Input = 19.44 MHz; Output = 644.531248 MHz, 2.5 V LVDS

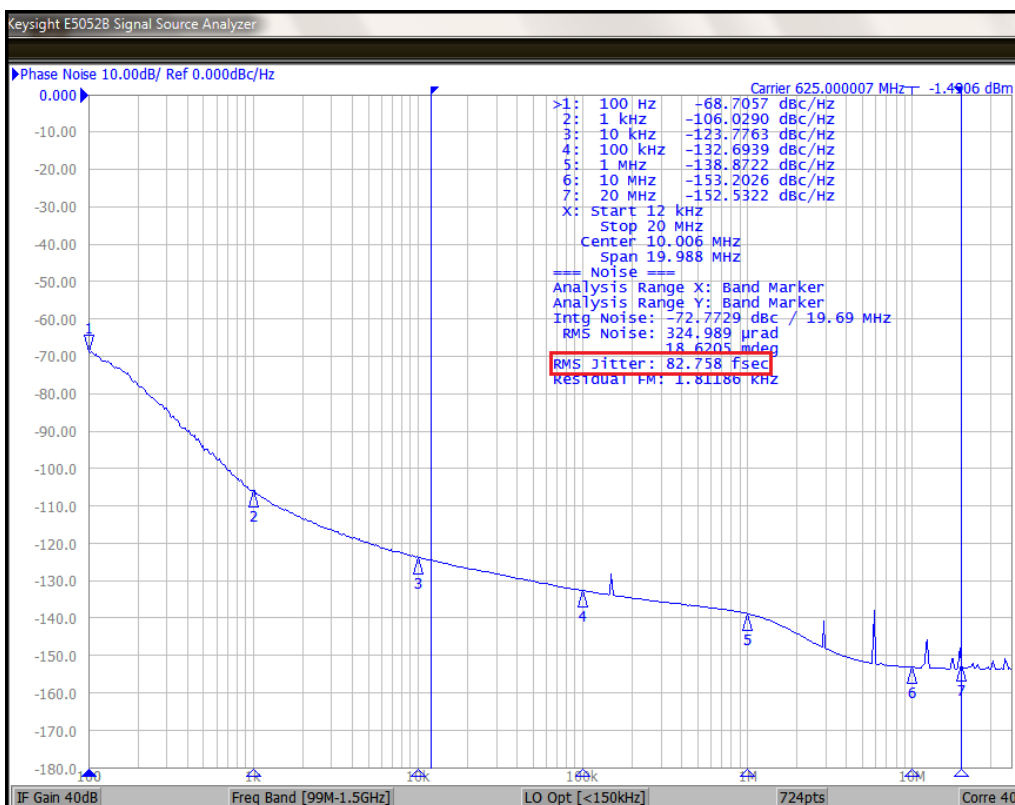

Figure 8.2. Input = 25 MHz; Output = 625 MHz, 2.5 V LVDS



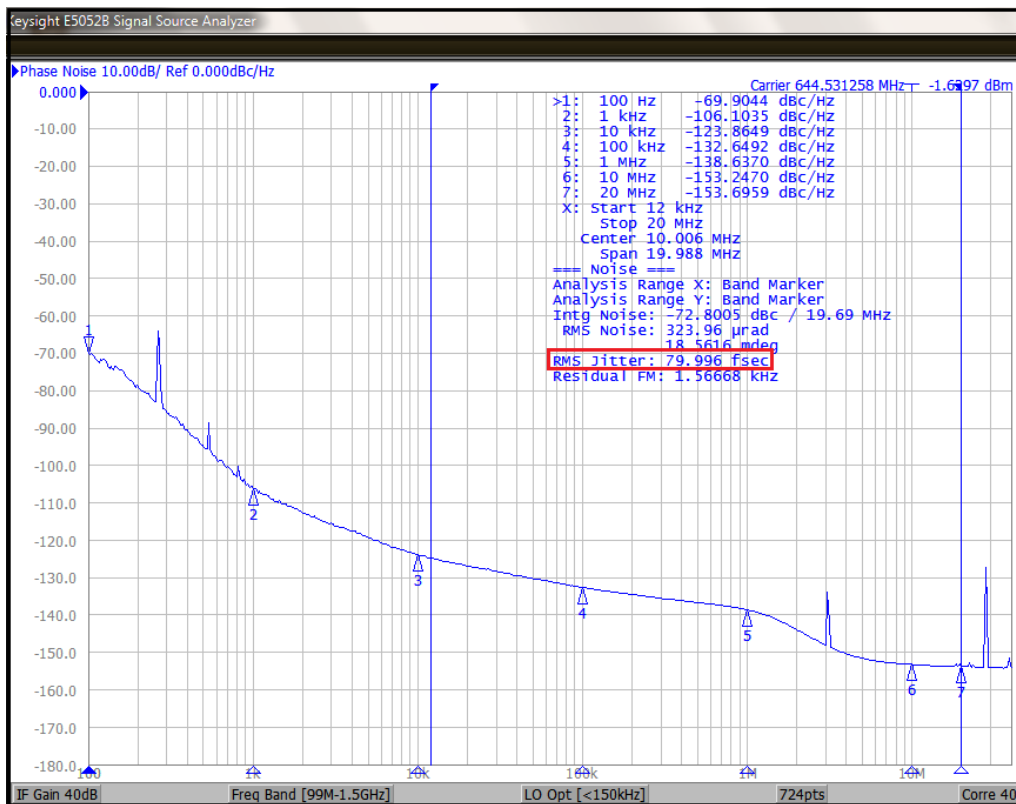

Figure 8.3. Input = 19.44 MHz; Output = 644.53125 MHz, 2.5 V LVDS

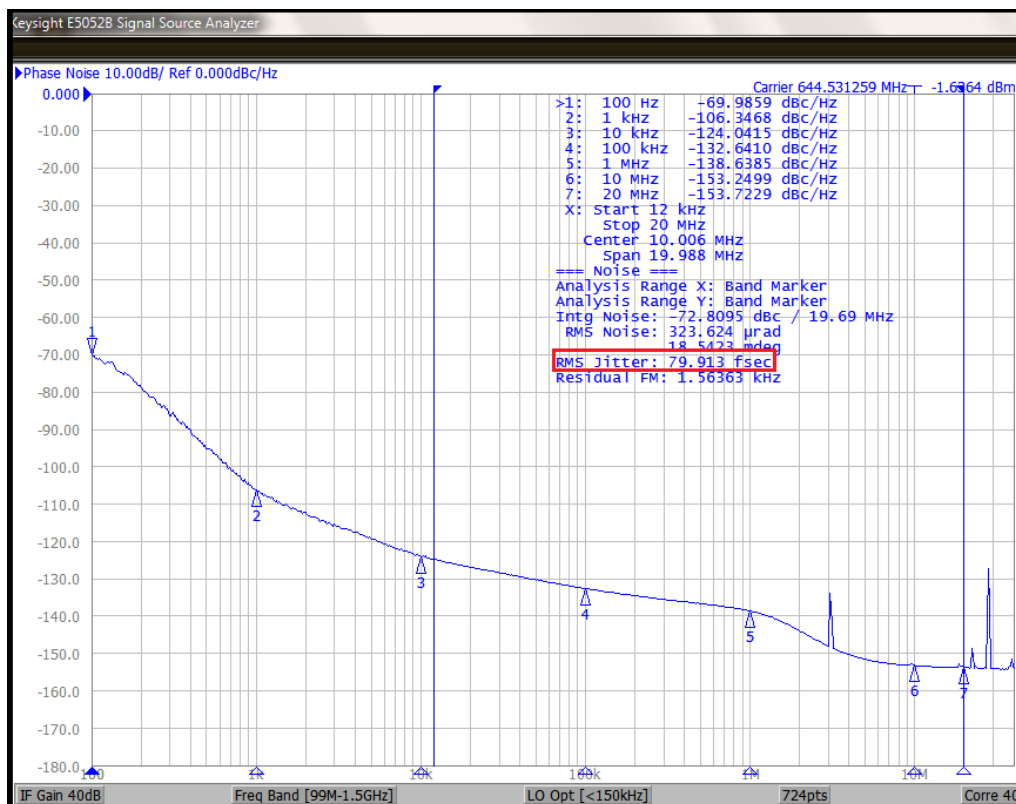
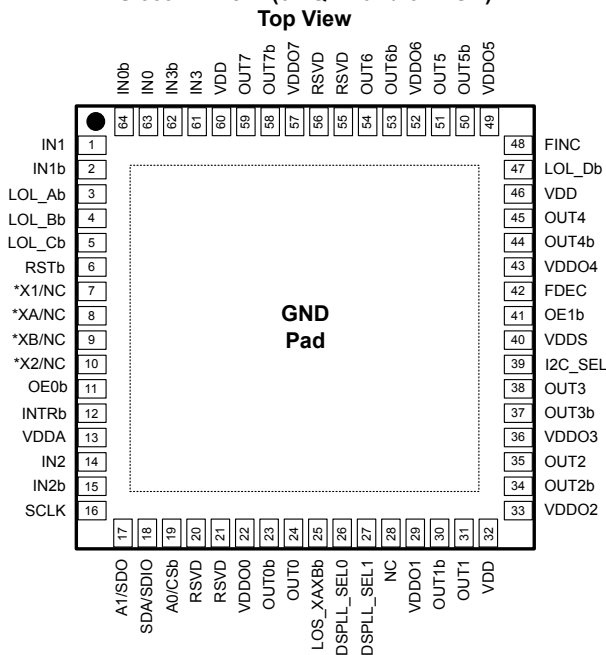

Figure 8.4. Input = 25 MHz; Output = 644.53125 MHz, 2.5 V LVDS

## 9. Pin Descriptions

Si5397A/B/J/K (64-QFN and 64-LGA)



Si5396A/B/J/K (44-QFN and 44-LGA)

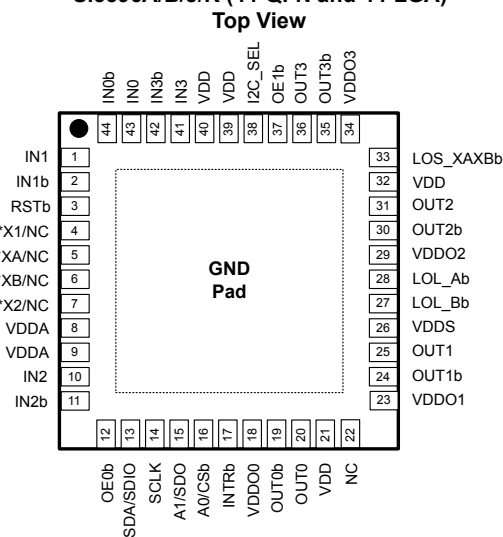

Si5397C/D/L/M (64-QFN and 64-LGA)

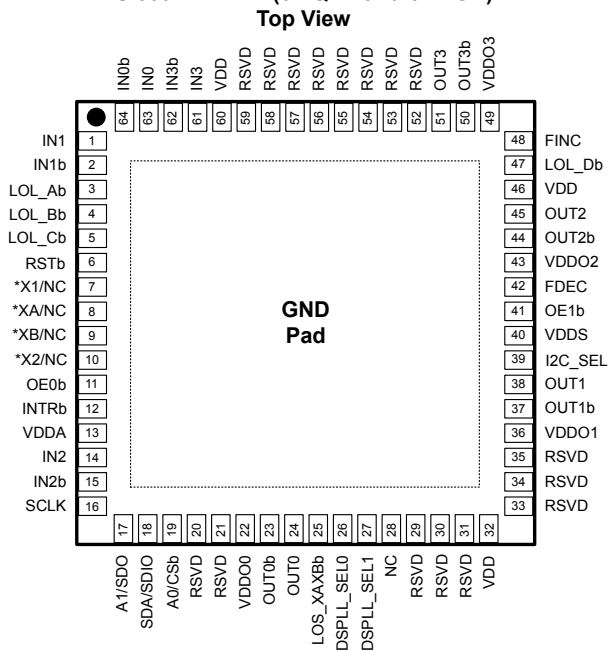

\*Grades A/B/C/D require external references so these pins can be connected to those references (XTAL, XO, VCXO etc). Note that connecting an external reference to a device that already has an internal reference is not recommended and could lead to internal damage to the circuits.

Table 9.1. Si5397/96 Pin Descriptions<sup>1</sup>

Pin Name	Pin Number			Pin Type <sup>2</sup>	Function
	Si5397A/B	Si5397C/D	Si5396		
<b>Inputs</b>					
XA/NC	8	8	5	I	<b>Crystal Input for Grade A/B/C/D.</b> Input pins for external crystal (XTAL). Alternatively these pins can be driven with an external reference clock (REFCLK). An internal register bit selects XTAL or REFCLK mode. Default is XTAL mode.
XB/NC	9	9	6	I	
X1/NC	7	7	4	I	<b>XTAL Shield for Grade A/B/C/D.</b> Connect these pins directly to the XTAL ground pins. X1, X2 and the XTAL ground pins should be separated from the PCB ground plane. Refer to the <a href="#">Si5397/96 Family Reference Manual</a> for layout guidelines.
X2/NC	10	10	7	I	
IN0	63	63	43	I	<b>Clock Inputs.</b> These pins accept an input clock for synchronizing the device. They support both differential and single-ended clock signals. Refer to for input termination options. These pins are high-impedance and must be terminated externally. The negative side of the differential input must be grounded when accepting a single-ended clock.
IN0b	64	64	44	I	
IN1	1	1	1	I	
IN1b	2	2	2	I	
IN2	14	14	10	I	
IN2b	15	15	11	I	
IN3	61	61	41	I	
IN3b	62	62	42	I	
<b>Outputs</b>					

Pin Name	Pin Number			Pin Type <sup>2</sup>	Function
	Si5397A/B	Si5397C/D	Si5396		
OUT0	24	24	20	O	<b>Output Clocks.</b> These output clocks support a programmable signal amplitude and common mode voltage. Desired output signal format is configurable using register control. Termination recommendations are provided in and . Unused outputs should be left unconnected.
OUT0b	23	23	19	O	
OUT1	31	38	25	O	
OUT1b	30	37	24	O	
OUT2	35	45	31	O	
OUT2b	34	44	30	O	
OUT3	38	51	36	O	
OUT3b	37	50	35	O	
OUT4	45	—	—	O	
OUT4b	44	—	—	O	
OUT5	51	—	—	O	
OUT5b	50	—	—	O	
OUT6	54	—	—	O	
OUT6b	53	—	—	O	
OUT7	59	—	—	O	
OUT7b	58	—	—	O	

Pin Name	Pin Number			Pin Type <sup>2</sup>	Function
	Si5397A/B	Si5397C/D	Si5396		
<b>Serial Interface</b>					
I2C_SEL	39	39	38	I	<b>I<sup>2</sup>C Select.</b> <sup>3</sup> This pin selects the serial interface mode as I <sup>2</sup> C (I2C_SEL = 1) or SPI (I2C_SEL = 0). This pin is internally pulled high.
SDA/SDIO	18	18	13	I/O	<b>Serial Data Interface.</b> <sup>3</sup> This is the bidirectional data pin (SDA) for the I <sup>2</sup> C mode, or the bidirectional data pin (SDIO) in the 3-wire SPI mode, or the input data pin (SDI) in 4-wire SPI mode. When in I <sup>2</sup> C mode, this is an open-drain output and must be pulled-up using an external resistor of at least 1 k $\Omega$ . No pull-up resistor is needed when in SPI mode, as the output is a push-pull driver. Tie low when unused.
A1/SDO	17	17	15	I/O	<b>Address Select 1/Serial Data Output.</b> <sup>3</sup> In I <sup>2</sup> C mode this pin is an open drain and functions as the A1 address input pin. It does not have an internal pull-up or pull-down resistor. In 4-wire SPI mode this output is a push pull driver and functions as the serial data output (SDO) pin. It drives high to the voltage selected by the IO_VDD_SEL bit. Leave disconnected when unused.
SCLK	16	16	14	I	<b>Serial Clock Input.</b> <sup>3</sup> This pin functions as the serial clock input for both I <sup>2</sup> C and SPI modes. When in I <sup>2</sup> C mode, this pin must be pulled-up using an external resistor of > 1 k $\Omega$ . No pull-up resistor is needed when in SPI mode.
A0/CSb	19	19	16	I	<b>Address Select 0/Chip Select.</b> <sup>3</sup> This pin functions as the hardware controlled address A0 in I <sup>2</sup> C mode. In SPI mode, this pin functions as the chip select input (active low). This pin is internally pulled-up.
<b>Control/Status</b>					
INTRb	12	12	17	O	<b>Interrupt.</b> <sup>3</sup> This pin is asserted low when a change in device status has occurred. It should be left unconnected when not in use.
RSTb	6	6	3	I	<b>Device Reset.</b> <sup>3</sup> Active low input that performs power-on reset (POR) of the device. Resets all internal logic to a known state and forces the device registers to their default values. Clock outputs are disabled during reset. This pin is internally pulled-up.
OE0b	11	11	12	I	<b>Output Enable 0.</b> <sup>3</sup> This pin is used to enable (when held low) and disable (when held high) the output clocks. By default this pin controls all outputs. It can also be configured to control a subset of outputs. See <a href="#">4.9.7 Output Enable/Disable</a> for details. This pin is internally pulled-down.

Pin Name	Pin Number			Pin Type <sup>2</sup>	Function
	Si5397A/B	Si5397C/D	Si5396		
OE1b	41	41	—		<b>Output Enable 1. (Si5397)<sup>4</sup></b> This is an additional output enable pin that can be configured to control a subset of outputs. By default it has no control on the outputs until configured. See <a href="#">4.9.7 Output Enable/Disable</a> for details. There is no internal pull-up/pull-down for this pin. This pin must be pulled up or down externally (do not leave floating when not in use).
	—	—	37		<b>Output Enable 1. (Si5396)<sup>3</sup></b> This is an additional output enable pin that can be configured to control a subset of outputs. By default it has no control on the outputs until configured. See <a href="#">4.9.7 Output Enable/Disable</a> for details. This pin is internally pulled-down.
LOL_Ab	3	3	28	O	<b>Loss Of Lock_A/B/C/D.<sup>3, 4</sup></b> These output pins indicate when DSPLL A, B, C, D is out-of-lock (low) or locked (high). They can be left unconnected when not in use. Si5397: See Note 3, Si5396: See Note 4.
LOL_Bb	4	4	27	O	
LOL_Cb	5	5	—	O	
LOL_Db	47	47	—	O	
LOS_XAXBb	25	25	33	O	<b>Status Pins.<sup>3</sup></b> This pin indicates a loss of signal alarm on the XA/XB pins. This either indicates a XTAL failure or a loss of external signal on the XA/XB pins. This pin can be left unconnected when unused.
DSPLL_SEL0	26	26	—	I	<b>DSPLL Select Pins (Si5397 only).<sup>3</sup></b> These pins are used in conjunction with the FINC and FDEC pins. The DSPLL_SEL[1:0] pins determine which DSPLL is affected by a frequency change using the FINC and FDEC pins. See <a href="#">4.5 Digitally-Controlled Oscillator (DCO) Mode</a> for details. These pins are internally pulled-down.
DSPLL_SEL1	27	27	—	I	
FDEC	42	42	—	I	<b>Frequency Decrement Pin (Si5397 only).<sup>4</sup></b> This pin is used to step-down the output frequency of a selected DSPLL. The frequency change step size is register configurable. The DSPLL that is affected by the frequency change is determined by the DSPLL_SEL[1:0] pins. This pin must be pulled up or down externally (do not leave floating when not in use).
FINC	48	48	—	I	<b>Frequency Increment Pin (Si5397 only).<sup>3</sup></b> This pin is used to step-up the output frequency of a selected DSPLL. The frequency change step size is register configurable. The DSPLL that is affected by the frequency change is determined by the DSPLL_SEL[1:0] pins. This pin is pulled low internally and can be left unconnected when not in use.

Pin Name	Pin Number			Pin Type <sup>2</sup>	Function
	Si5397A/B	Si5397C/D	Si5396		
RSVD	20	20	—	—	<b>Reserved.</b> These pins are connected to the die. Leave disconnected.
	21	21	—	—	
	—	29	—	—	
	—	30	—	—	
	—	31	—	—	
	—	33	—	—	
	—	34	—	—	
	—	35	—	—	
	—	52	—	—	
	—	53	—	—	
	—	54	—	—	
	55	55	—	—	
	56	56	—	—	
	—	57	—	—	
—	58	—	—		
—	59	—	—		
NC	28	28	22	—	<b>No Connect.</b> These pins are not connected to the die. Leave disconnected.
<b>Power</b>					
VDD	32	32	21	P	<b>Core Supply Voltage.</b> The device core operates from a 1.8 V supply. See the <a href="#">Si5397/96 Family Reference Manual</a> for power supply filtering recommendations. A 0402 1 $\mu$ F capacitor should be placed very near each of these pins.
	46	46	32		
	60	60	39		
	—	—	40		
VDDA	13	13	8	P	<b>Core Supply Voltage 3.3 V.</b> This core supply pin requires a 3.3 V power source. See the <a href="#">Si5397/96 Family Reference Manual</a> for power supply filtering recommendations. A 0402 1 $\mu$ F capacitor should be placed very near each of these pins.
	—	—	9	P	
VDDS	40	40	26	P	<b>Status Output Voltage.</b> The voltage on this pin determines VOL/VOH on the Si5396 LOL_Ab and LOL_Bb outputs. On the Si5397, this pin determines VIL/VIH for the FDEC and OE1b inputs. Connect to either 3.3 V or 1.8 V. A 0.1 $\mu$ F bypass capacitor should be placed very close to this pin.

Pin Name	Pin Number			Pin Type <sup>2</sup>	Function
	Si5397A/B	Si5397C/D	Si5396		
VDDO0	22	22	18	P	<b>Output Clock Supply Voltage 0–7.</b> Supply voltage (3.3 V, 2.5 V, 1.8 V) for OUTn, OUTnb outputs. A 0.1 $\mu$ F bypass capacitor should be placed very close to this pin. Leave VDDO pins of unused output drivers unconnected. An alternate option is to connect the VDDO pin to a power supply and disable the output driver to minimize current consumption. A 0402 1 $\mu$ F capacitor should be placed very near each of these pins.
VDDO1	29	36	23	P	
VDDO2	33	43	29	P	
VDDO3	36	49	34	P	
VDDO4	43	—	—	P	
VDDO5	49	—	—	P	
VDDO6	52	—	—	P	
VDDO7	57	—	—	P	
GND PAD	—	—	—	P	<b>Ground Pad.</b> This pad provides connection to ground and must be connected for proper operation. Use as many vias as practical and keep the via length to an internal ground plan as short as possible.

**Notes:**

1. Refer to the [Si5397/96 Family Reference Manual](#) for more information on register setting names.
2. I = Input, O = Output, P = Power.
3. The IO\_VDD\_SEL control bit (0x0943 bit 0) selects 3.3 V or 1.8 V operation.
4. The voltage on the VDDS pin(s) determines 3.3 V or 1.8 V operation.
5. All status pins except I<sup>2</sup>C and SPI are push-pull.



## 10. Package Outlines

### 10.1 Si5397 9x9 mm 64-QFN Package Diagram

The figure below illustrates the package details for the Si5397 A/B/C/D. The table below lists the values for the dimensions shown in the illustration.

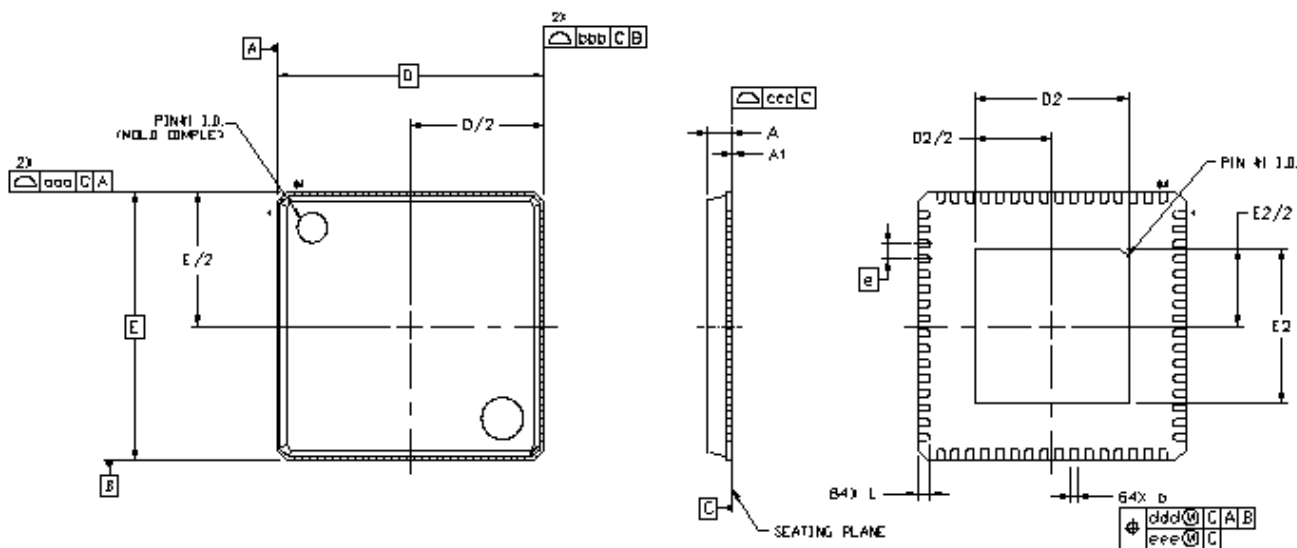

Figure 10.1. 64-Pin Quad Flat No-Lead (QFN)

Table 10.1. Package Dimensions

Dimension	Min	Nom	Max
A	0.80	0.85	0.90
A1	0.00	0.02	0.05
b	0.18	0.25	0.30
D	9.00 BSC		
D2	5.10	5.20	5.30
e	0.50 BSC		
E	9.00 BSC		
E2	5.10	5.20	5.30
L	0.30	0.40	0.50
aaa	—	—	0.15
bbb	—	—	0.10
ccc	—	—	0.08
ddd	—	—	0.10

#### Notes:

1. All dimensions shown are in millimeters (mm) unless otherwise noted.
2. Dimensioning and Tolerancing per ANSI Y14.5M-1994.
3. This drawing conforms to the JEDEC Solid State Outline MO-220.
4. Recommended card reflow profile is per the JEDEC/IPC J-STD-020 specification for Small Body Components.



### 10.3 Si5396 7x7 mm 44-QFN Package Diagram

The figure below illustrates the package details for the Si5396 A/B. The table below lists the values for the dimensions shown in the illustration.

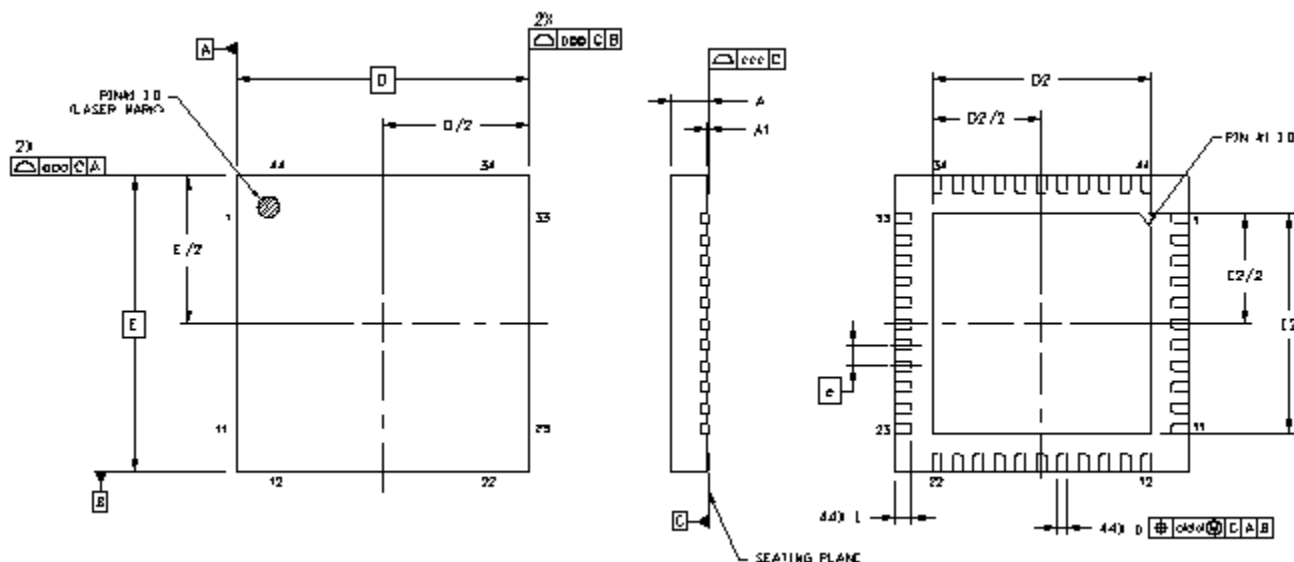

Figure 10.3. 44-Pin Quad Flat No-Lead (QFN)

Table 10.3. Package Dimensions

Dimension	Min	Nom	Max
A	0.80	0.85	0.90
A1	0.00	0.02	0.05
b	0.18	0.25	0.30
D	7.00 BSC		
D2	5.10	5.20	5.30
e	0.50 BSC		
E	7.00 BSC		
E2	5.10	5.20	5.30
L	0.30	0.40	0.50
aaa	—	—	0.15
bbb	—	—	0.10
ccc	—	—	0.08
ddd	—	—	0.10

**Notes:**

1. All dimensions shown are in millimeters (mm) unless otherwise noted.
2. Dimensioning and Tolerancing per ANSI Y14.5M-1994.
3. This drawing conforms to the JEDEC Solid State Outline MO-220.
4. Recommended card reflow profile is per the JEDEC/IPC J-STD-020 specification for Small Body Components.

## 10.4 Si5396 7x7 mm 44-LGA Package Diagram

The following figure illustrates the package details for the Si5396 J/K. The table lists the values for the dimensions shown in the illustration.



Figure 10.4. 44-Pin Quad Flat No-Lead (QFN)

Table 10.4. Package Dimensions

Dimension	Min	Nom	Max
A	0.80	0.85	0.90
A1	0.00	0.02	0.05
b	0.18	0.25	0.30
D	7.00 BSC		
D2	5.10	5.20	5.30
e	0.50 BSC		
E	7.00 BSC		
E2	5.10	5.20	5.30
L	0.30	0.40	0.50
aaa	—	—	0.10
bbb	—	—	0.10
ccc	—	—	0.08
ddd	—	—	0.10

**Note:**

1. All dimensions shown are in millimeters (mm) unless otherwise noted.
2. Dimensioning and Tolerancing per ANSI Y14.5M-1994.
3. This drawing conforms to the JEDEC Solid State Outline MO-220.
4. Recommended card reflow profile is per the JEDEC/IPC J-STD-020 specification for Small Body Components.

## 11. PCB Land Pattern

The figure below illustrates the PCB land pattern details for the devices. The table below lists the values for the dimensions shown in the illustration. Refer to the [Si5397/96 Family Reference Manual](#) for information about thermal via recommendations.

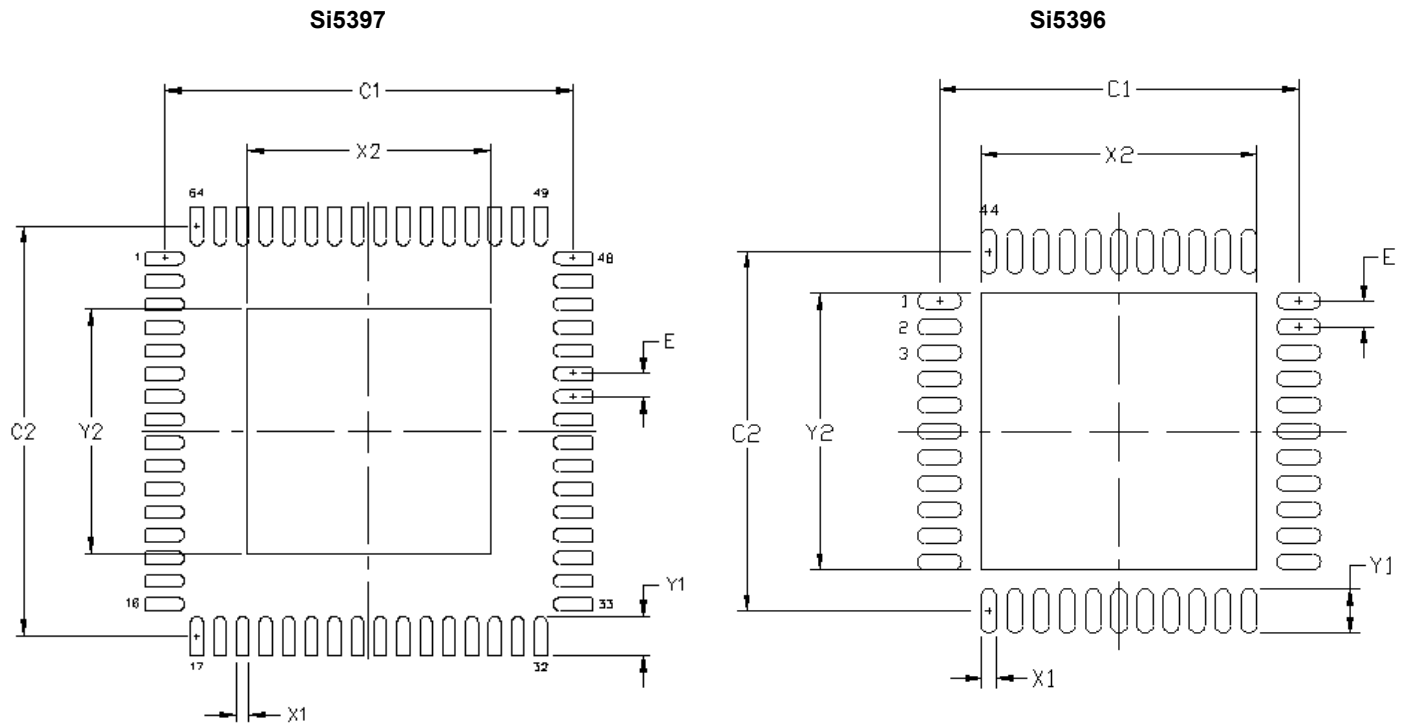

Figure 11.1. PCB Land Pattern

Table 11.1. PCB Land Pattern Dimensions

Dimension	Si5397 (Max)	Si5396 (Max)
C1	8.90	6.90
C2	8.90	6.90
E	0.50	0.50
X1	0.30	0.30
Y1	0.85	0.85
X2	5.30	5.30
Y2	5.30	5.30

**Notes:****General**

1. All dimensions shown are in millimeters (mm) unless otherwise noted.
2. This Land Pattern Design is based on the IPC-7351 guidelines.
3. All dimensions shown are at Maximum Material Condition (MMC). Least Material Condition is calculated based on a fabrication Allowance of 0.05 mm.

**Solder Mask Design**

1. All metal pads are to be non-solder mask defined (NSMD). Clearance between the solder mask and the metal pad is to be 60 µm minimum, all the way around the pad.

**Stencil Design**

1. A stainless steel, laser-cut and electro-polished stencil with trapezoidal walls should be used to assure good solder paste release.
2. The stencil thickness should be 0.125 mm (5 mils).
3. The ratio of stencil aperture to land pad size should be 1:1 for all perimeter pads.
4. While the same land pattern design can be used for both QFN and LGA package types, the stencil design will need to match the respective ground pads as shown in the Package outline.

**Card Assembly**

1. A No-Clean, Type-3 solder paste is recommended.
2. The recommended card reflow profile is per the JEDEC/IPC J-STD-020 specification for Small Body Components.

## 12. Top Marking

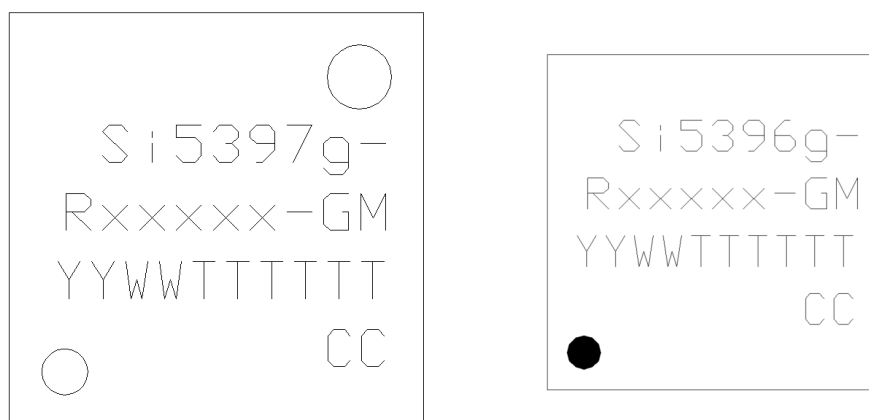

Figure 12.1. Top Marking

Table 12.1. Top Marking Explanation

Line	Characters	Description
1	Si5397g- Si5396g-	Base part number and Device Grade. Si5397: Quad/Dual PLL; 64-QFN Si5396: Dual PLL; 44-QFN g = Device Grade (A/B/C/D/J/K/L/M). See 3. <a href="#">Ordering Guide</a> for more information. – = Dash character.
2	Rxxxxx-GM	R = Product revision. (See 3. <a href="#">Ordering Guide</a> for current revision.) xxxxx = Customer specific NVM sequence number. (Optional NVM code assigned for custom, factory pre-programmed devices. Characters are not included for standard, factory default configured devices). See 3. <a href="#">Ordering Guide</a> for more information. -GM = Package (QFN) and temperature range (–40 to +85 °C).
3	YYWWTTTTTT	YYWW = Characters correspond to the year (YY) and work week (WW) of package assembly. TTTTTT = Manufacturing trace code.
4	CC	CC = Taiwan; Country of Origin (ISO Abbreviation)

## 13. Revision History

### Revision 1.0

June, 2019

- Add Integrated reference options J/K/L/M
- Updated Figure 4.3. Crystal Resonator and External Reference Clock Connection Options
- Table 5.2 DC Characteristics
  - Core supply current IDD/IDDA limits clarified for each device
  - Output Buffer supply conditions clarified
  - Total power dissipation numbers updated
  - Updated test configuration diagrams
- Table 5.3 Input clock specifications
  - Updated Input voltage section of "LVCMOS / Pulsed CMOS DC-Coupled Input Buffer" to include standard CMOS
- Table 5.5 Differential Clock Output Specifications
  - Increased max Rise and Fall times from 150ps to 200ps based on final characterization
- Table 5.6. LVCMOS Clock Output Specifications
  - Updated Min and Max limits for duty cycle
  - Updated test configuration diagrams
- Table 5.8. Performance Characteristics
  - Updated hitless switching specifications
- Updated Table 5.10. SPI Timing Specifications (4-Wire) table and timing diagram
- Updated Table 5.11. SPI Timing Specifications (3-Wire)
- Changed NC/XA, NC/XB, NC/X1, NC/X2 to XA, XB, X1, X2 respectively since integrated crystal devices are getting their own data sheet

### Revision 0.96

June, 2018

Preliminary data sheet.





## ClockBuilder Pro

One-click access to Timing tools, documentation, software, source code libraries & more. Available for Windows and iOS (CBGo only).

[www.silabs.com/CBPro](http://www.silabs.com/CBPro)



**Timing Portfolio**  
[www.silabs.com/timing](http://www.silabs.com/timing)



**SW/HW**  
[www.silabs.com/CBPro](http://www.silabs.com/CBPro)



**Quality**  
[www.silabs.com/quality](http://www.silabs.com/quality)



**Support and Community**  
[community.silabs.com](http://community.silabs.com)

### Disclaimer

Silicon Labs intends to provide customers with the latest, accurate, and in-depth documentation of all peripherals and modules available for system and software implementers using or intending to use the Silicon Labs products. Characterization data, available modules and peripherals, memory sizes and memory addresses refer to each specific device, and "Typical" parameters provided can and do vary in different applications. Application examples described herein are for illustrative purposes only. Silicon Labs reserves the right to make changes without further notice to the product information, specifications, and descriptions herein, and does not give warranties as to the accuracy or completeness of the included information. Without prior notification, Silicon Labs may update product firmware during the manufacturing process for security or reliability reasons. Such changes will not alter the specifications or the performance of the product. Silicon Labs shall have no liability for the consequences of use of the information supplied in this document. This document does not imply or expressly grant any license to design or fabricate any integrated circuits. The products are not designed or authorized to be used within any FDA Class III devices, applications for which FDA premarket approval is required or Life Support Systems without the specific written consent of Silicon Labs. A "Life Support System" is any product or system intended to support or sustain life and/or health, which, if it fails, can be reasonably expected to result in significant personal injury or death. Silicon Labs products are not designed or authorized for military applications. Silicon Labs products shall under no circumstances be used in weapons of mass destruction including (but not limited to) nuclear, biological or chemical weapons, or missiles capable of delivering such weapons. Silicon Labs disclaims all express and implied warranties and shall not be responsible or liable for any injuries or damages related to use of a Silicon Labs product in such unauthorized applications.

### Trademark Information

Silicon Laboratories Inc.®, Silicon Laboratories®, Silicon Labs®, SiLabs® and the Silicon Labs logo®, Bluegiga®, Bluegiga Logo®, Clockbuilder®, CMEMS®, DSPLL®, EFM®, EFM32®, EFR®, Ember®, Energy Micro, Energy Micro logo and combinations thereof, "the world's most energy friendly microcontrollers", Ember®, EZLink®, EZRadio®, EZRadioPRO®, Gecko®, Gecko OS, Gecko OS Studio, ISOmodem®, Precision32®, ProSLIC®, Simplicity Studio®, SiPHY®, Telegesis, the Telegesis Logo®, USBXpress®, Zentri, the Zentri logo and Zentri DMS, Z-Wave®, and others are trademarks or registered trademarks of Silicon Labs. ARM, CORTEX, Cortex-M3 and THUMB are trademarks or registered trademarks of ARM Holdings. Keil is a registered trademark of ARM Limited. Wi-Fi is a registered trademark of the Wi-Fi Alliance. All other products or brand names mentioned herein are trademarks of their respective holders.



Silicon Laboratories Inc.  
400 West Cesar Chavez  
Austin, TX 78701  
USA

<http://www.silabs.com>

Компания «Life Electronics» занимается поставками электронных компонентов импортного и отечественного производства от производителей и со складов крупных дистрибьюторов Европы, Америки и Азии.

С конца 2013 года компания активно расширяет линейку поставок компонентов по направлению коаксиальный кабель, кварцевые генераторы и конденсаторы (керамические, пленочные, электролитические), за счёт заключения дистрибьюторских договоров

Мы предлагаем:

- Конкуренспособные цены и скидки постоянным клиентам.
- Специальные условия для постоянных клиентов.
- Подбор аналогов.
- Поставку компонентов в любых объемах, удовлетворяющих вашим потребностям.
- Приемлемые сроки поставки, возможна ускоренная поставка.
- Доставку товара в любую точку России и стран СНГ.
- Комплексную поставку.
- Работу по проектам и поставку образцов.
- Формирование склада под заказчика.
- Сертификаты соответствия на поставляемую продукцию (по желанию клиента).
- Тестирование поставляемой продукции.
- Поставку компонентов, требующих военную и космическую приемку.
- Входной контроль качества.
- Наличие сертификата ISO.

В составе нашей компании организован Конструкторский отдел, призванный помогать разработчикам, и инженерам.

Конструкторский отдел помогает осуществить:

- Регистрацию проекта у производителя компонентов.
- Техническую поддержку проекта.
- Защиту от снятия компонента с производства.
- Оценку стоимости проекта по компонентам.
- Изготовление тестовой платы монтаж и пусконаладочные работы.



Тел: +7 (812) 336 43 04 (многоканальный)

Email: [org@lifeelectronics.ru](mailto:org@lifeelectronics.ru)