

## Low voltage 1 $\Omega$ single-pole double-throw analog switch with break-before-make feature

Datasheet - production data

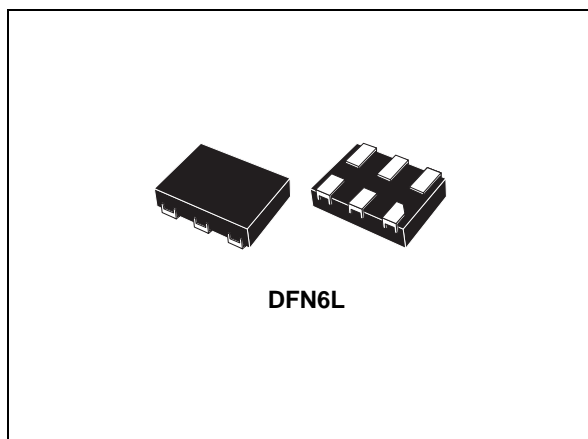

### Features

- High speed:
  - $t_{PD} = 130$  ps (typ.) at  $V_{CC} = 3.0$  V
  - $t_{PD} = 140$  ps (typ.) at  $V_{CC} = 2.3$  V
- Ultra low power dissipation:
  - $I_{CC} = 0.2$   $\mu$ A (max.) at  $T_A = 85$   $^{\circ}$ C
- Low ON resistance:
  - $R_{ON} = 1.0$   $\Omega$  (typ.) at  $V_{CC} = 4.5$  V
  - $R_{ON} = 1.2$   $\Omega$  (typ.) at  $V_{CC} = 3.0$  V
  - $R_{ON} = 2.0$   $\Omega$  (typ.) at  $V_{CC} = 1.8$  V
- Wide operating voltage range:
  - $V_{CC}$  (opr.) = 1.65 to 4.5 V single supply
- 5 V tolerant and 1.8 V compatible threshold ON digital control input at  $V_{CC} = 1.65$  to 4.5 V
- Latch-up performance exceeds 200 mA per JESD 78, Class II
- ESD performance tested per JESD 22
  - 2000 V human-body model (A114-B, Class II)
  - 200 V machine model (A115-A)
- 1000 V charged-device model (C101)

### Description

The AS11P2TLR is a high speed CMOS low voltage single analog SPDT (single-pole double-throw) switch or 2:1 multiplexer/demultiplexer switch manufactured using silicon gate C<sup>2</sup>MOS technology. Designed to operate from a 1.65 to 4.5 V supply, this device is ideal for portable applications.

The device offers very low ON-resistance (1  $\Omega$ ) at  $V_{CC} = 4.5$  V. Switch S1 is ON (connected to common ports Dn) when the SEL input is held high, and OFF (state of high impedance exists between the two ports) when SEL is held low.

Switch S2 is ON (connected to common port D) when the SEL input is held low, and OFF (state of high impedance exists between the two ports) when SEL is held high.

Additional key features are fast switching speed, break-before-make delay time and ultralow power consumption. All inputs and outputs are equipped with protection circuits to protect against static discharge, giving them immunity from ESD and transient excess voltage.

**Table 1. Device summary**

Order code	Package	Packaging
AS11P2TLRQ	DFN6L (1.2 x 1 mm)	Tape and reel

# Contents

<b>1</b>	<b>Pin connections and functions</b> .....	<b>3</b>
<b>2</b>	<b>Electrical ratings</b> .....	<b>4</b>
<b>3</b>	<b>Electrical characteristics</b> .....	<b>5</b>
3.1	DC electrical characteristics .....	5
3.2	AC electrical characteristics .....	6
3.3	Analog switch characteristics .....	7
<b>4</b>	<b>Test circuits</b> .....	<b>8</b>
<b>5</b>	<b>Package information</b> .....	<b>12</b>
<b>6</b>	<b>Revision history</b> .....	<b>17</b>

# 1 Pin connections and functions

Figure 1. Pin connections (top through view)

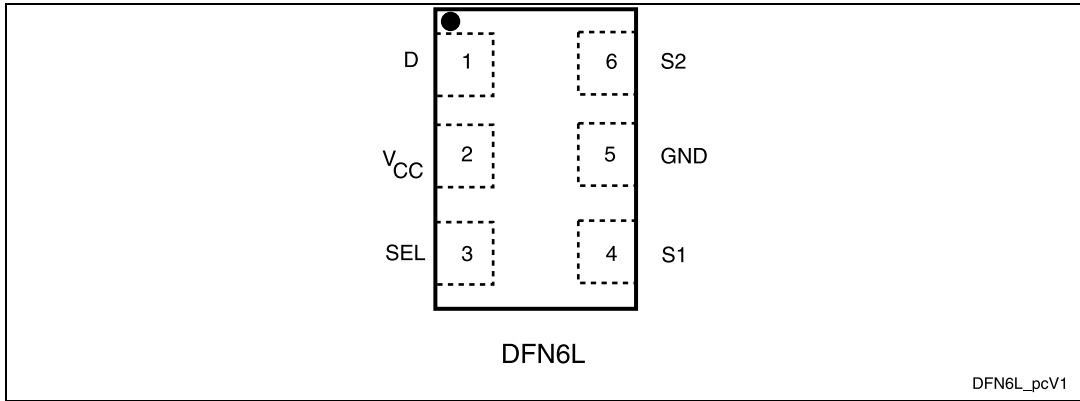

Table 2. Pin descriptions

Pin number	Symbol	Name and function
4	S1	Independent channel
6	S2	Independent channel
1	D	Common channels
3	SEL	Control
2	V <sub>CC</sub>	Positive supply voltage
5	GND	Ground (0 V)

Figure 2. Input equivalent circuit

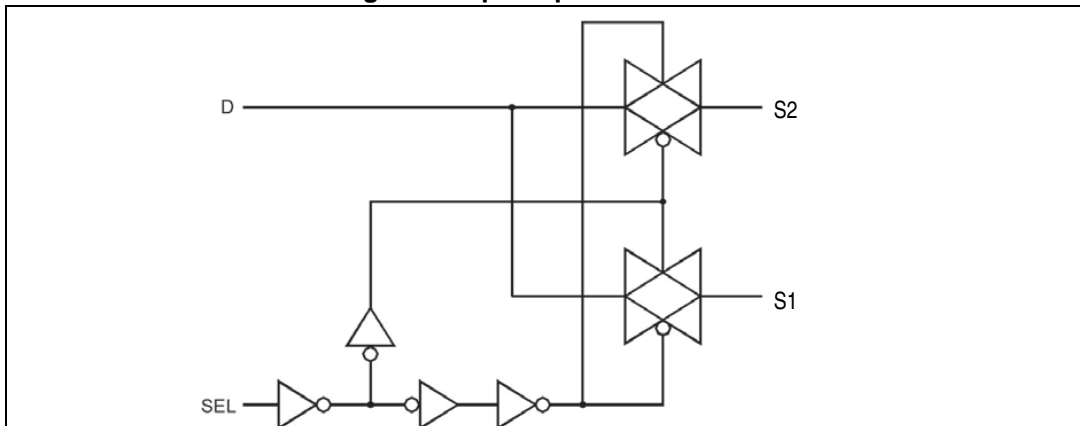

Table 3. Truth table

Sel	Switch S1	Switch S2
H	ON	OFF <sup>(1)</sup>
L	OFF <sup>(1)</sup>	ON

1. High impedance.

## 2 Electrical ratings

Stressing the device above the rating listed in [Table 4: Absolute maximum ratings](#) may cause permanent damage to the device. These are stress ratings only and operation of the device at these or any other conditions above those indicated in [Table 5: Recommended operating conditions](#) of this specification is not implied. Exposure to absolute maximum rating conditions for extended periods may affect device reliability. Refer also to the STMicroelectronics™ SURE program and other relevant quality documents.

**Table 4. Absolute maximum ratings**

Symbol	Parameter	Value	Unit
$V_{CC}$	Supply voltage	-0.5 to 5.5	V
$V_I$	DC input voltage	-0.5 to $V_{CC} + 0.5$	V
$V_{IC}$	DC control input voltage	-0.5 to 5.5	V
$V_O$	DC output voltage	-0.5 to $V_{CC} + 0.5$	V
$I_{IKC}$	DC input diode current on control pin ( $V_{SEL} < 0$ V)	-50	mA
$I_{IK}$	DC input diode current ( $V_{IN} < 0$ V)	±50	mA
$I_{OK}$	DC output diode current	±20	mA
$I_O$	DC output current	±200	mA
$I_{OP}$	DC output current peak (pulse at 1 ms, 10% duty cycle)	±400	mA
$I_{CC}$ or $I_{GND}$	DC $V_{CC}$ or ground current	±100	mA
$P_D$	Power dissipation at $T_A = 70$ °C <sup>(1)</sup>	1120	mW
$T_{STG}$	Storage temperature	-65 to 150	°C
$T_L$	Lead temperature (10 s)	300	°C

1. Derate above 70 °C by 18.5 mW/°C.

**Table 5. Recommended operating conditions**

Symbol	Parameter	Value	Unit
$V_{CC}$	Supply voltage	1.65 to 4.5	V
$V_I$	Input voltage	0 to $V_{CC}$	V
$V_{IC}$	Control input voltage	0 to 4.5	V
$V_O$	Output voltage	0 to $V_{CC}$	V
$T_{op}$	Operating temperature	-40 to 85	°C
dt/dv	Input rise and fall time control input	$V_{CC} = 1.65$ to $2.7$ V	0 to 20
		$V_{CC} = 3.0$ to $4.5$ V	0 to 10

### 3 Electrical characteristics

#### 3.1 DC electrical characteristics

Table 6. DC specifications

Symbol	Parameter	V <sub>CC</sub> (V)	Test condition	Value					Unit
				T <sub>A</sub> = 25 °C			-40 to 85 °C		
				Min.	Typ.	Max.	Min.	Max.	
V <sub>IH</sub>	High level input voltage	1.65 – 1.95		0.65 V <sub>CC</sub>			0.65 V <sub>CC</sub>		V
		2.3 – 2.5		1.2			1.2		
		2.7 – 3.0		1.3			1.3		
		3.3 – 3.6		1.4			1.4		
		4.5		1.6			1.6		
V <sub>IL</sub>	Low level input voltage	1.65 – 1.95				0.40		0.40	V
		2.3 – 2.5				0.60		0.60	
		2.7 – 3.0				0.60		0.60	
		3.3 – 3.6				0.60		0.60	
		4.5				0.80		0.80	
R <sub>ON</sub>	Switch ON-resistance	1.8	V <sub>S</sub> = 0 V to V <sub>CC</sub> I <sub>S</sub> = 100 mA		2.0	3.0		3.5	Ω
		2.7			1.3	1.6		1.8	
		3.0			1.2	1.5		1.7	
		4.5			1.0	1.2		1.4	
ΔR <sub>ON</sub>	ON-resistance match between channels <sup>(1)</sup>	1.8	V <sub>S</sub> at R <sub>ON</sub> max I <sub>S</sub> = 100 mA		0.06				Ω
		2.7			0.05				
		3.0			0.05				
		4.5			0.05				
R <sub>FLAT</sub>	ON-resistance flatness <sup>(2)</sup>	1.8	V <sub>S</sub> = 0 V to V <sub>CC</sub> I <sub>S</sub> = 100 mA		1.0	1.5		1.5	Ω
		2.7			0.45	0.60		0.70	
		3.0			0.43	0.50		0.60	
		4.5			0.39	0.50		0.60	
I <sub>OFF</sub>	OFF state leakage current (Sn), (D)	4.3	V <sub>S</sub> = 0.3 or 4 V			±20		±100	nA
I <sub>IN</sub>	Input leakage current	0 – 4.5	V <sub>SEL</sub> = 0 to 4.5 V			±0.1		±1.0	μA
I <sub>CC</sub>	Quiescent supply current	1.65 – 4.5	V <sub>SEL</sub> = V <sub>CC</sub> or GND			±0.1		±1.0	μA

Table 6. DC specifications (continued)

Symbol	Parameter	V <sub>CC</sub> (V)	Test condition	Value					Unit
				T <sub>A</sub> = 25 °C			-40 to 85 °C		
				Min.	Typ.	Max.	Min.	Max.	
I <sub>CCLV</sub>	Quiescent supply current low voltage driving	4.3	V <sub>SEL</sub> = 1.65 V		±17	±35		±70	μA
		4.3	V <sub>SEL</sub> = 1.80 V		±15	±30		±60	
		4.3	V <sub>SEL</sub> = 2.60 V		±5	±10		±20	

1.  $\Delta R_{ON} = R_{ON(Max)} - R_{ON(Min)}$
2. Flatness is defined as the difference between the maximum and minimum value of ON-resistance as measured over the specified analog signal ranges.

### 3.2 AC electrical characteristics

Table 7. AC electrical characteristics (C<sub>L</sub> = 35 pF, R<sub>L</sub> = 50 Ω, t<sub>r</sub> = t<sub>f</sub> ≤ 5 ns)

Symbol	Parameter	V <sub>CC</sub> (V)	Test conditions	Value					Unit
				T <sub>A</sub> = 25 °C			- 40 to 85 °C		
				Min.	Typ.	Max.	Min.	Max.	
t <sub>PLH</sub> , t <sub>PHL</sub>	Propagation delay	1.65 – 1.95			0.15				ns
		2.3 – 2.7			0.14				
		3.0 – 3.3			0.13				
		3.6 – 5.0			0.13				
t <sub>ON</sub>	Turn-ON time	1.65 – 1.95	V <sub>S</sub> = 0.8 V		36				ns
		2.3 – 2.7	V <sub>S</sub> = 1.5 V		31	40		45	
		3.0 – 3.3			24	31		40	
		3.6 – 5.0			21	28		32	
t <sub>OFF</sub>	Turn-OFF time	1.65 – 1.95	V <sub>S</sub> = 0.8 V		29				ns
		2.3 – 2.7	V <sub>S</sub> = 1.5 V		17	27		37	
		3.0 – 3.3			12	23		33	
		3.6 – 5.0			11	21		31	
t <sub>D</sub>	Break-before-make time delay	1.65 – 1.95	C <sub>L</sub> = 35 pF R <sub>L</sub> = 50 Ω V <sub>S</sub> = 1.5 V		15				ns
		2.3 – 2.7			10				
		3.0 – 3.3			8				
		3.6 – 5.0			6				
Q	Charge injection	1.65	C <sub>L</sub> = 100 pF V <sub>GEN</sub> = 0 V R <sub>GEN</sub> = 0 Ω		16				pC
		2.3			22				
		3			26				
		5.0			33				

### 3.3 Analog switch characteristics

Table 8. Analog switch characteristics ( $C_L = 5 \text{ pF}$ ,  $R_L = 50 \text{ } \Omega$ ,  $T_A = 25 \text{ } ^\circ\text{C}$ )

Symbol	Parameter	$V_{CC}$ (V)	Test conditions	Value					Unit
				$T_A = 25 \text{ } ^\circ\text{C}$			$-40 \text{ to } 85 \text{ } ^\circ\text{C}$		
				Min.	Typ.	Max.	Min.	Max.	
OIRR	OFF isolation <sup>(1)</sup>	1.65 – 5.0	$V_S = 1 V_{RMS}$ $f = 100 \text{ kHz}$		- 75				dB
Xtalk	Crosstalk	1.6 – 5.0	$V_S = 1 V_{RMS}$ $f = 100 \text{ kHz}$		- 80				dB
THD	Total harmonic distortion	2.3 – 5.0	$R_L = 600 \text{ } \Omega$ $V_S = 2 V_{PP}$ $f = 20 \text{ Hz to } 20 \text{ kHz}$		0.03				%
BW	-3 dB bandwidth	1.65 – 5.0	$R_L = 50 \text{ } \Omega$		150				MHz
$C_{IN}$	Control pin input capacitance				6				pF
$C_{ON}$	Sn port capacitance when switch is enabled	3.3	$f = 1 \text{ MHz}$		52				
$C_{OFF}$	Sn port capacitance when switch is disabled	3.3	$f = 1 \text{ MHz}$		25				
$C_D$	D port capacitance when switch is enabled	3.3	$f = 1 \text{ MHz}$		50				

1. OFF isolation =  $20 \log_{10} (V_D/V_S)$ ,  $V_D$  = output.  $V_S$  = input to OFF switch.

# 4 Test circuits

Figure 3. ON resistance

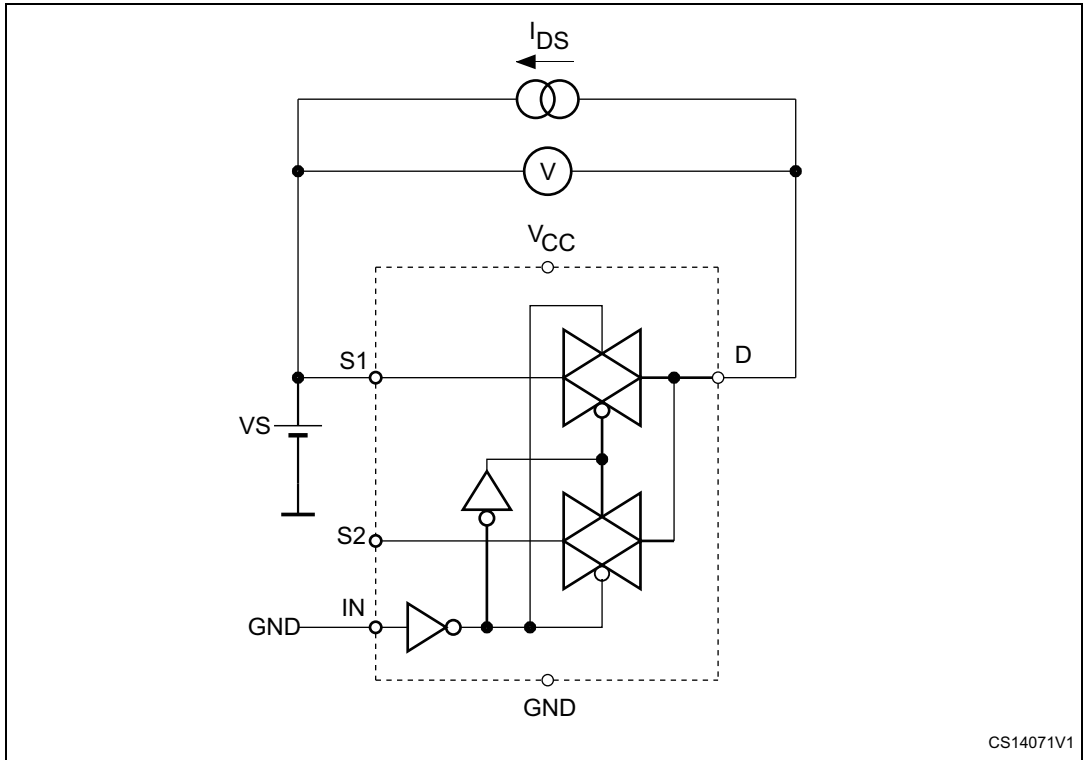

Figure 4. Bandwidth

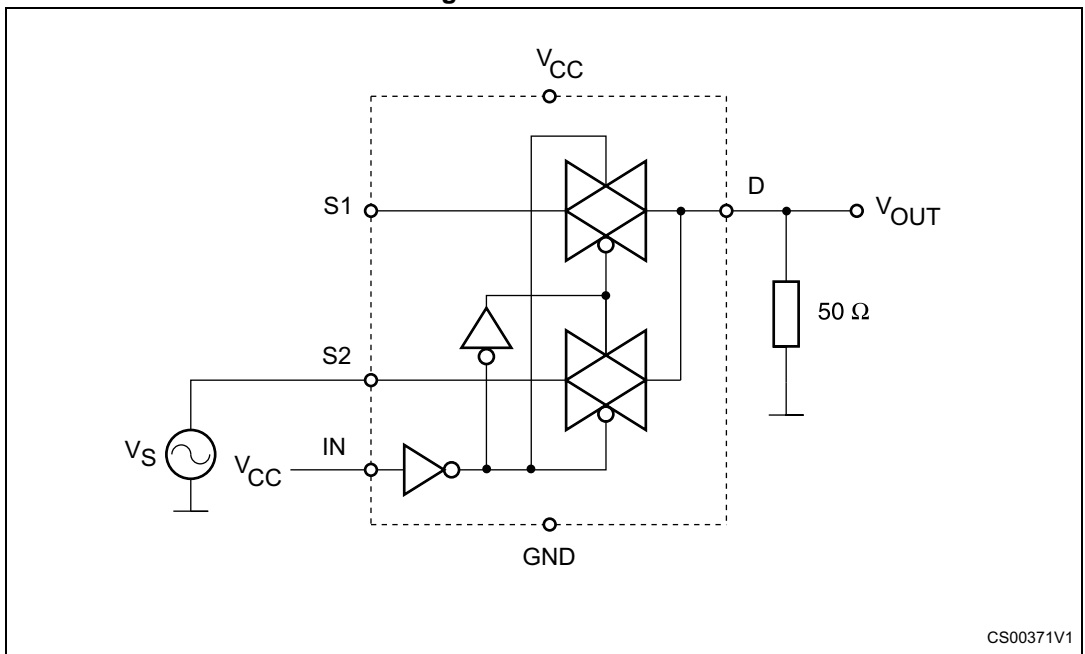



Figure 5. OFF leakage

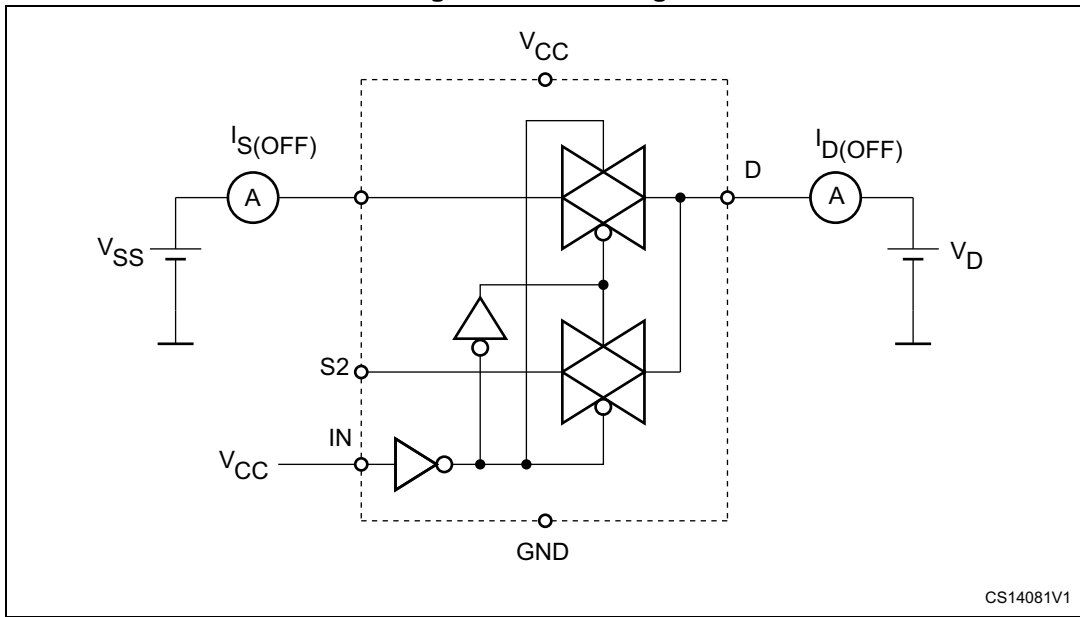

Figure 6. Channel-to-channel crosstalk

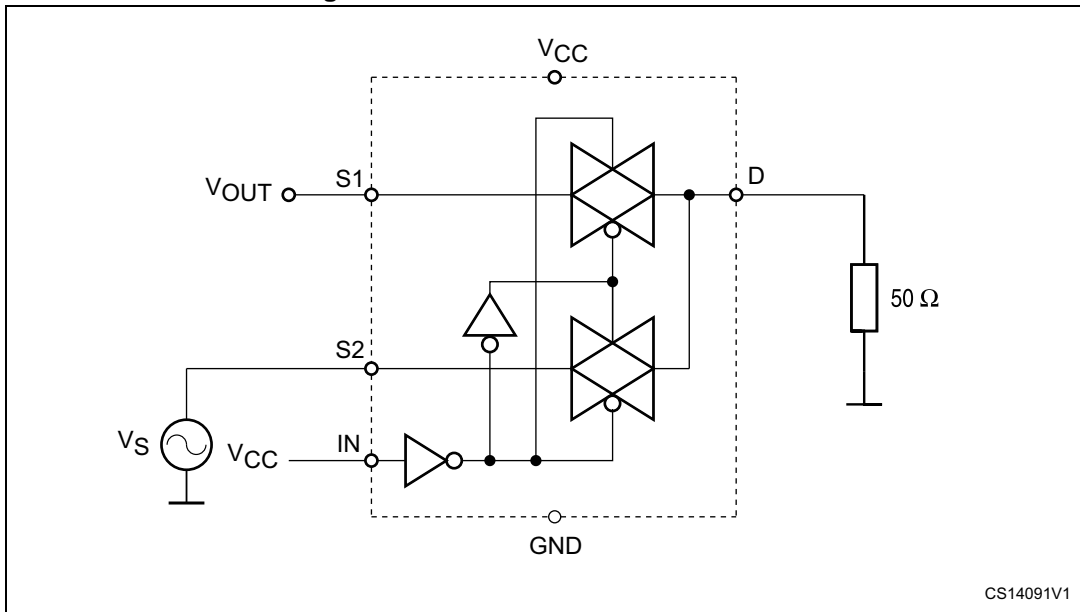

Figure 7. OFF isolation

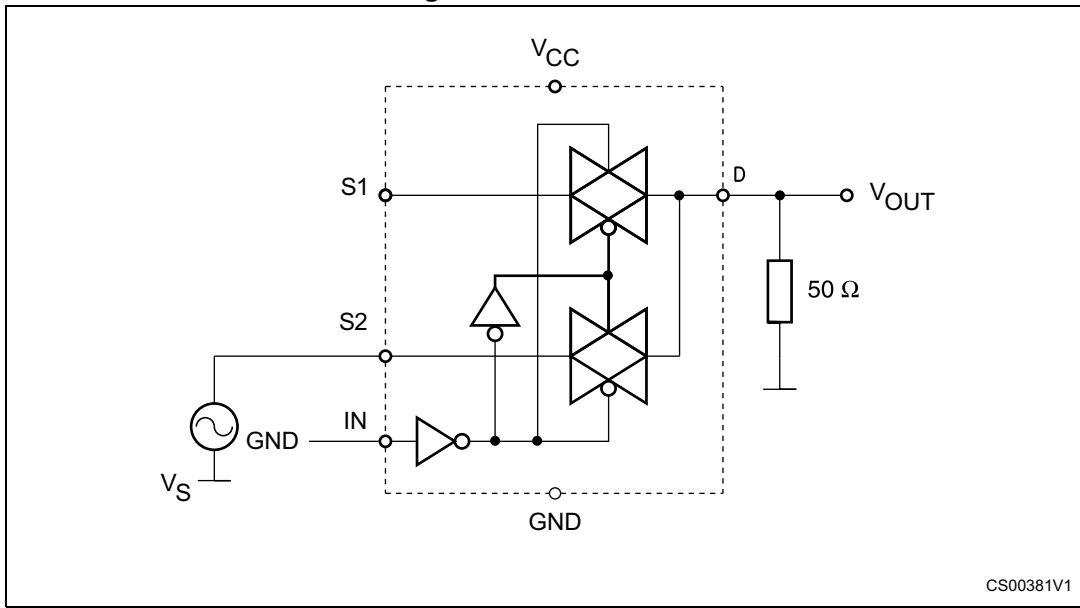
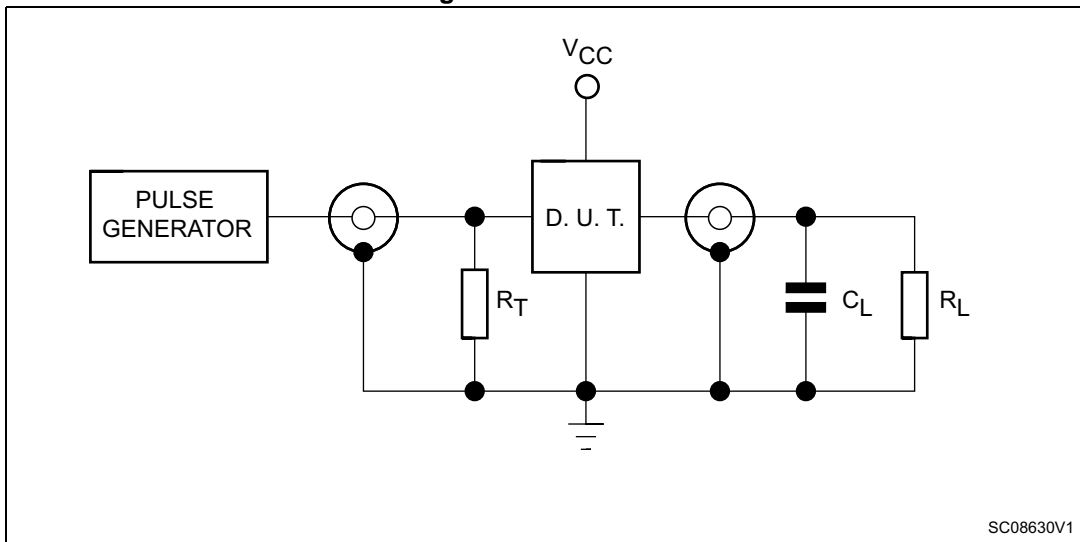

Figure 8. Test circuit



1.  $C_L = 5/35$  pF or equivalent: (includes jig capacitance).
2.  $R_L = 50 \Omega$  or  $\epsilon\theta\upsilon\iota\omega\alpha\lambda\epsilon\nu\tau$ .
3.  $R_T = Z_{OUT}$  of pulse generator (typically  $50 \Omega$ ).

Figure 9. Break-before-make time delay

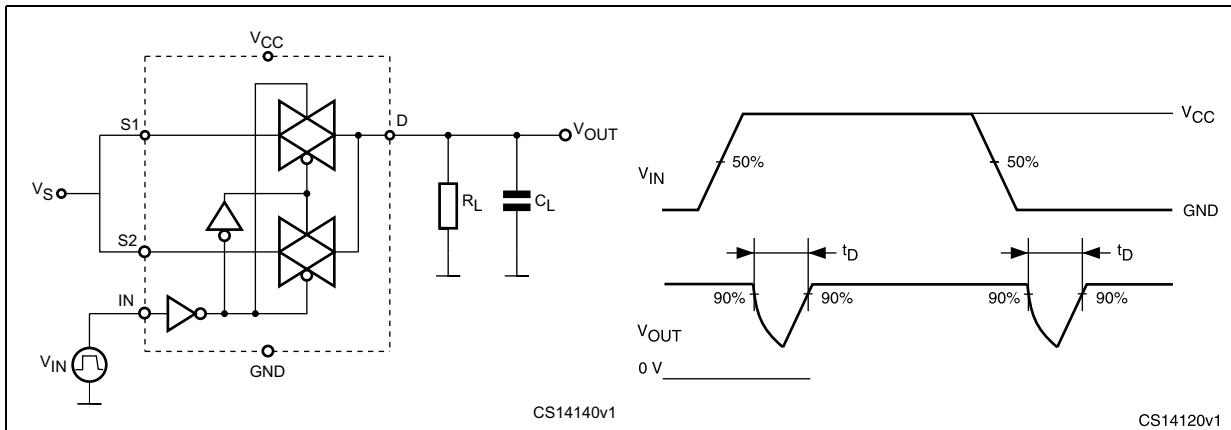

Figure 10. Switching time and charge injection ( $V_{GEN} = 0\text{ V}$ ,  $R_{GEN} = 0\ \Omega$ ,  $R_L = 1\text{ M}\Omega$ ,  $C_L = 100\text{ pF}$ )

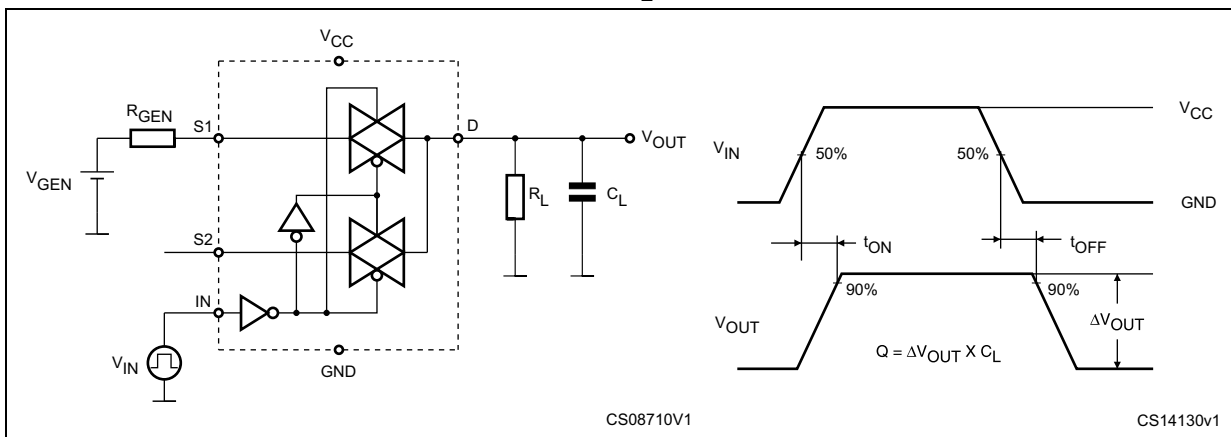
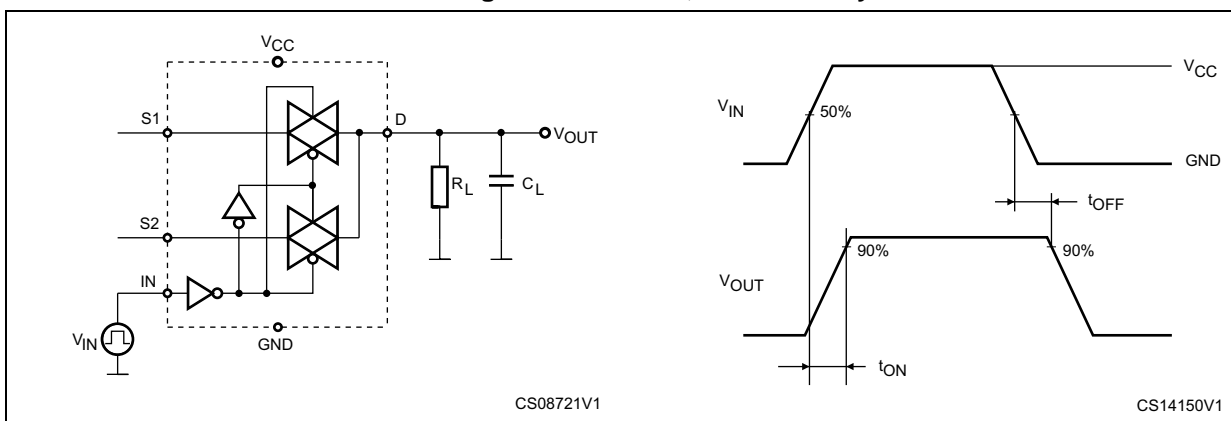

Figure 11. Turn-on, turn-off delay time



# 5 Package information

In order to meet environmental requirements, ST offers these devices in different grades of ECOPACK® packages, depending on their level of environmental compliance. ECOPACK specifications, grade definitions and product status are available at: [www.st.com](http://www.st.com). ECOPACK is an ST trademark.

**Figure 12. DFN6L (1.2 x 1 mm) package outline**

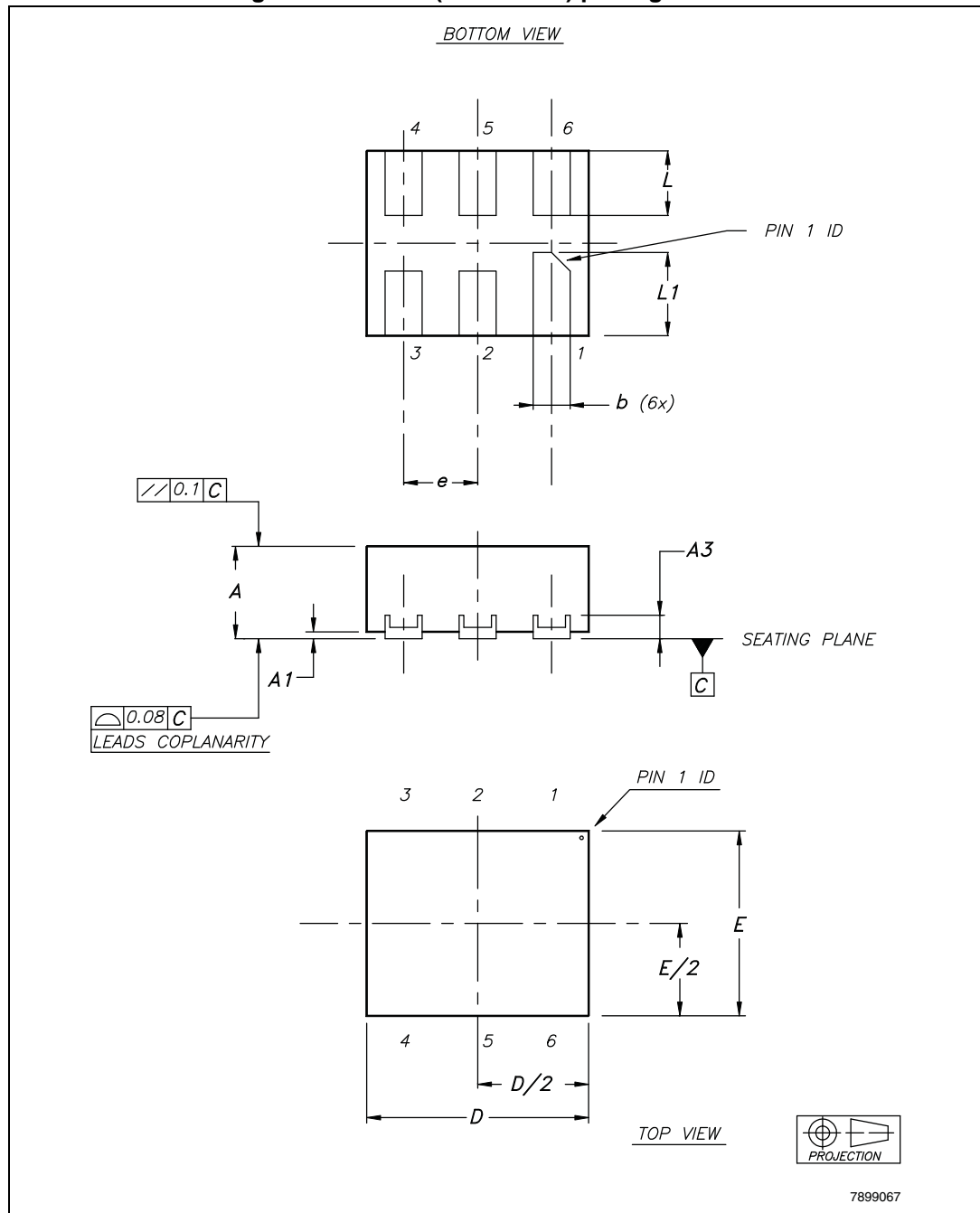

1. Drawing is not to scale.

Table 9. DFN6L (1.2 x 1 mm) mechanical data

Symbol	Dimensions (millimeters)		
	Typ.	Min.	Max.
A	0.50	0.45	0.55
A1	0.02	0	0.05
A3	0.127		
b	0.20	0.15	0.25
D	1.20	1.15	1.25
E	1	0.95	1.05
e	0.40		
L	0.35	0.30	0.40
L1	0.45	0.40	0.50

Figure 13. DFN6L (1.2 x 1 mm) footprint recommendation

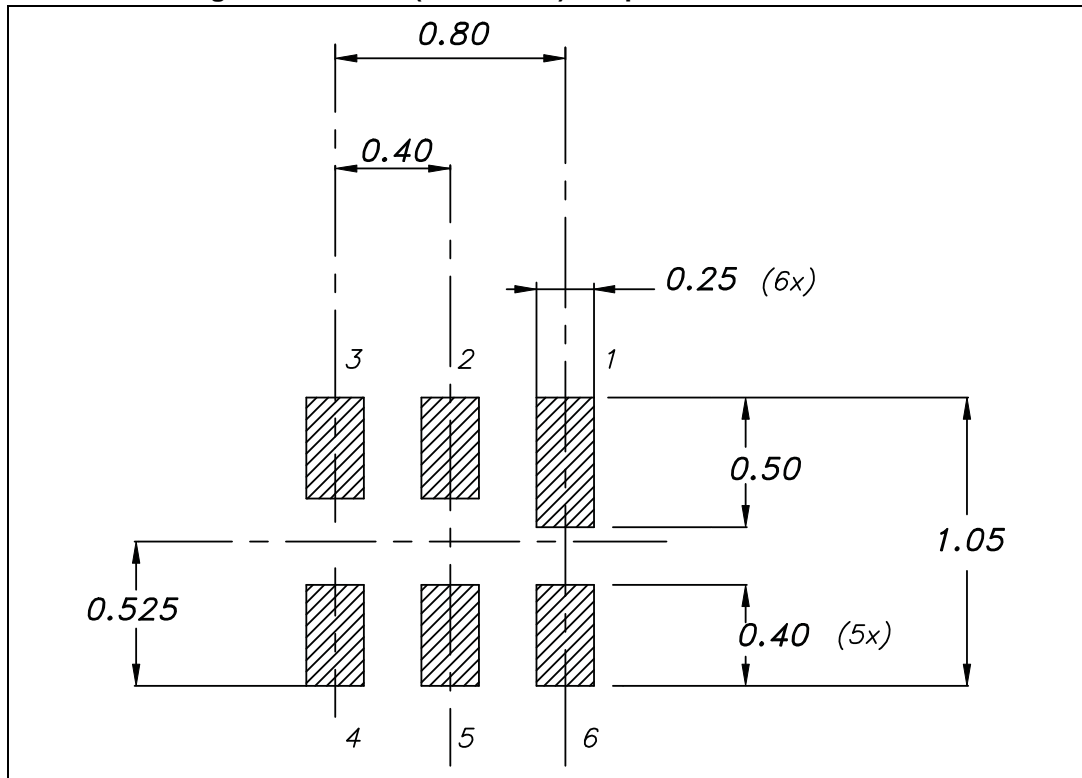
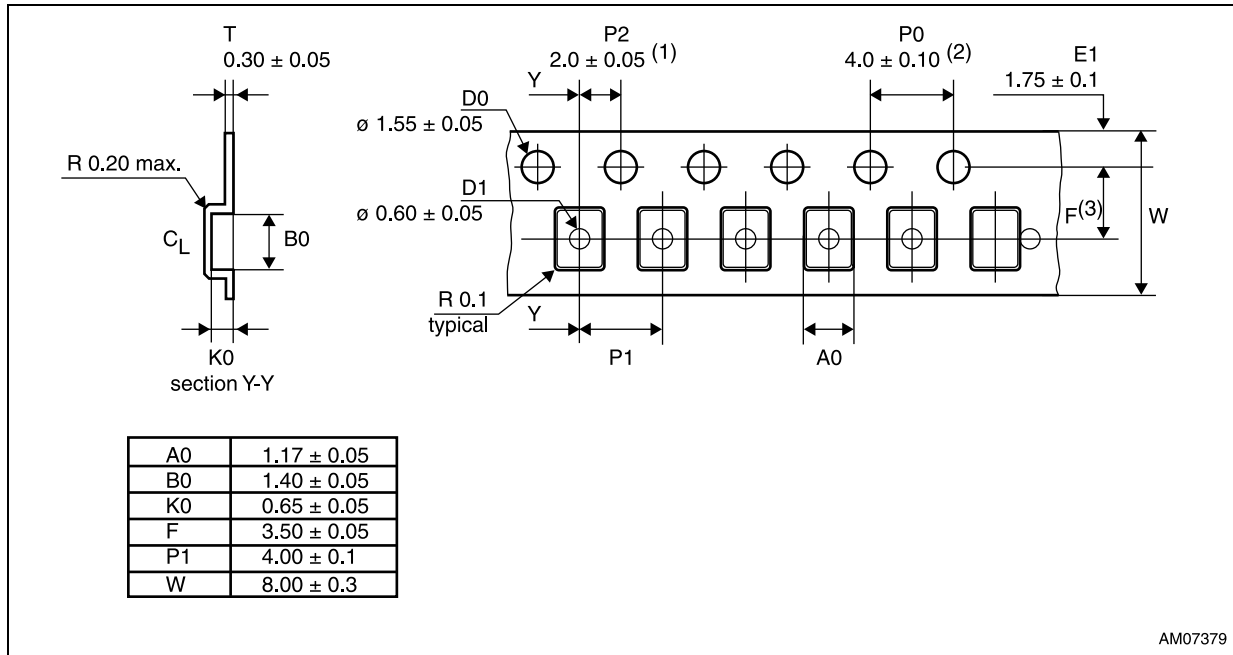

Figure 14. DFN6L carrier tape information



AM07379

1. Measured from centreline of sprocket hole to centreline of pocket.
2. Cumulative tolerance of 10 sprocket holes is ± 0.20.
3. Measured from centreline of sprocket hole to centreline of pocket.
4. Other material available.
5. Drawing is not to scale.
6. All dimensions are in millimeters unless otherwise stated.

Figure 15. DFN6L reel information drawing (back view)

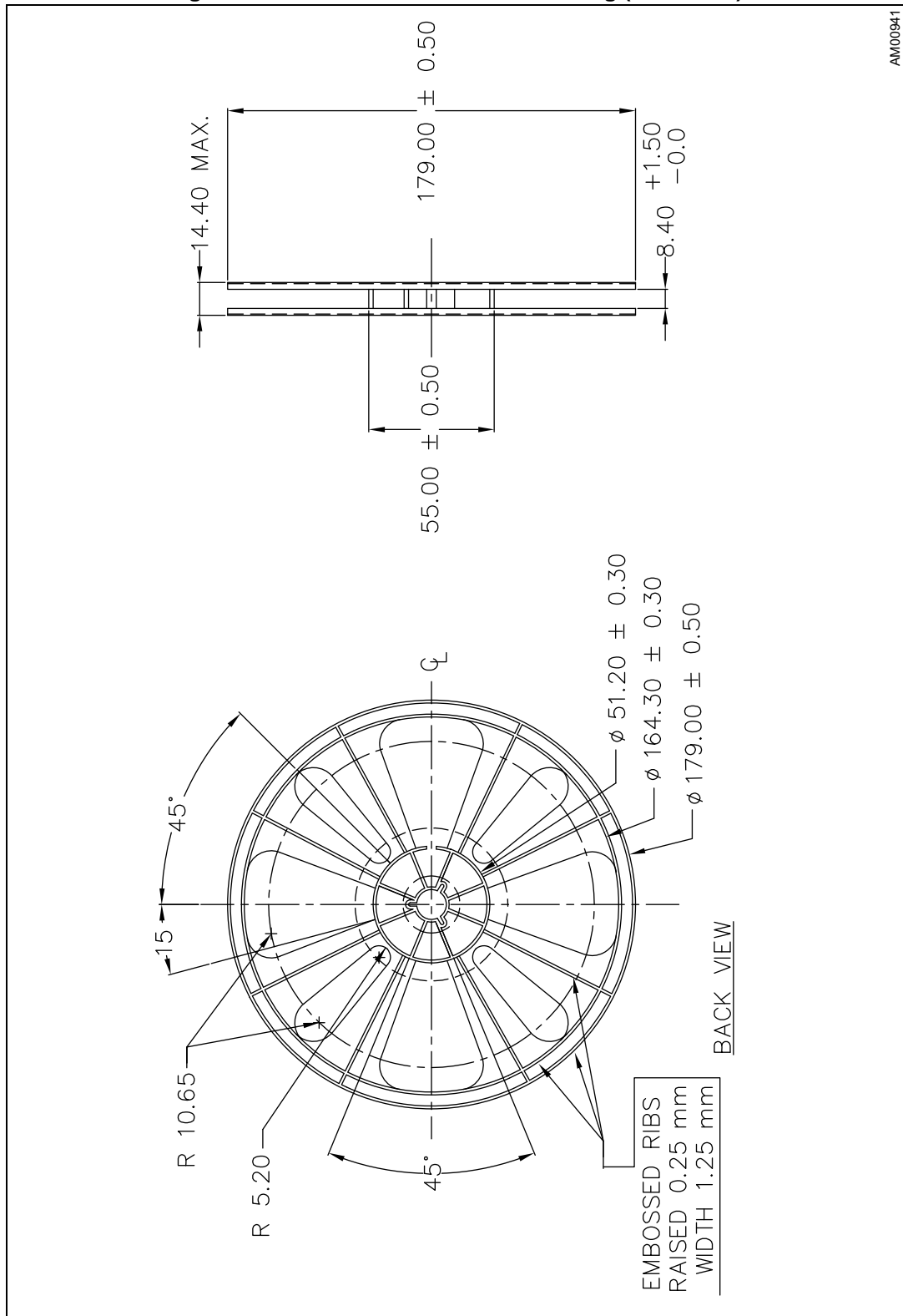

1. Drawing is not to scale.
2. Dimensions are in millimeters.

Figure 16. DFN6L reel information drawing (front view)

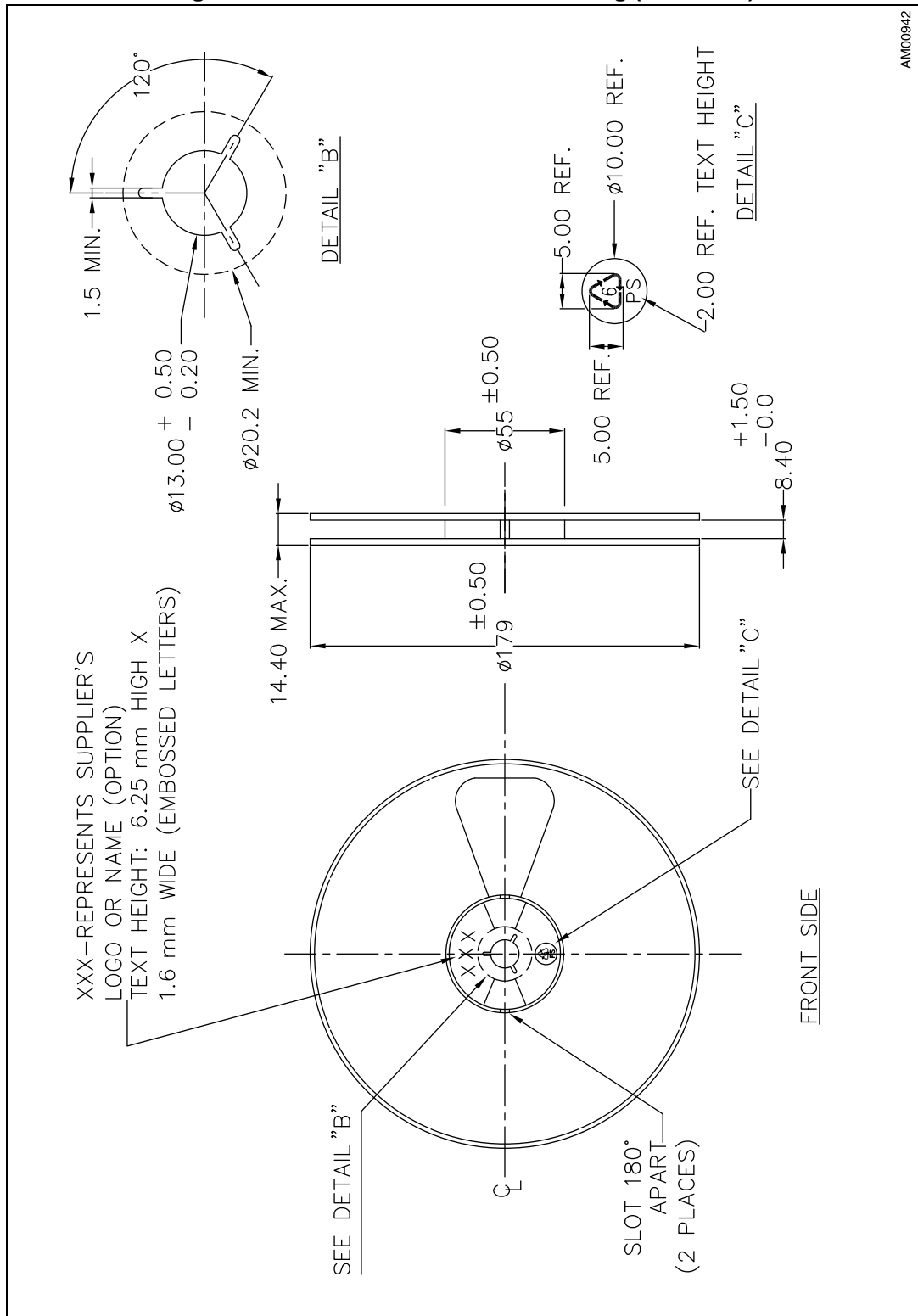

1. Drawing not to scale.  
Dimensions are in millimeters.



## 6 Revision history

**Table 10. Document revision history**

Date	Revision	Changes
07-Mar-2014	1	Initial release.
08-Nov-2017	2	Updated order code AS11P2TLR with AS11P2TLRQ <a href="#">Table 1: Device summary.</a>

**IMPORTANT NOTICE – PLEASE READ CAREFULLY**

STMicroelectronics NV and its subsidiaries (“ST”) reserve the right to make changes, corrections, enhancements, modifications, and improvements to ST products and/or to this document at any time without notice. Purchasers should obtain the latest relevant information on ST products before placing orders. ST products are sold pursuant to ST’s terms and conditions of sale in place at the time of order acknowledgement.

Purchasers are solely responsible for the choice, selection, and use of ST products and ST assumes no liability for application assistance or the design of Purchasers’ products.

No license, express or implied, to any intellectual property right is granted by ST herein.

Resale of ST products with provisions different from the information set forth herein shall void any warranty granted by ST for such product.

ST and the ST logo are trademarks of ST. All other product or service names are the property of their respective owners.

Information in this document supersedes and replaces information previously supplied in any prior versions of this document.

© 2017 STMicroelectronics – All rights reserved

Компания «Life Electronics» занимается поставками электронных компонентов импортного и отечественного производства от производителей и со складов крупных дистрибьюторов Европы, Америки и Азии.

С конца 2013 года компания активно расширяет линейку поставок компонентов по направлению коаксиальный кабель, кварцевые генераторы и конденсаторы (керамические, пленочные, электролитические), за счёт заключения дистрибьюторских договоров

Мы предлагаем:

- Конкурентоспособные цены и скидки постоянным клиентам.
- Специальные условия для постоянных клиентов.
- Подбор аналогов.
- Поставку компонентов в любых объемах, удовлетворяющих вашим потребностям.
- Приемлемые сроки поставки, возможна ускоренная поставка.
- Доставку товара в любую точку России и стран СНГ.
- Комплексную поставку.
- Работу по проектам и поставку образцов.
- Формирование склада под заказчика.
- Сертификаты соответствия на поставляемую продукцию (по желанию клиента).
- Тестирование поставляемой продукции.
- Поставку компонентов, требующих военную и космическую приемку.
- Входной контроль качества.
- Наличие сертификата ISO.

В составе нашей компании организован Конструкторский отдел, призванный помогать разработчикам, и инженерам.

Конструкторский отдел помогает осуществить:

- Регистрацию проекта у производителя компонентов.
- Техническую поддержку проекта.
- Защиту от снятия компонента с производства.
- Оценку стоимости проекта по компонентам.
- Изготовление тестовой платы монтаж и пусконаладочные работы.



Тел: +7 (812) 336 43 04 (многоканальный)

Email: [org@lifeelectronics.ru](mailto:org@lifeelectronics.ru)