

Hi-Reliability GaAlAs Infrared Emitting Diode

OP223, OP224 (TX, TXV), OP224 (S)



Features:

- Processed to OPTEK's military screening program, patterned after MIL-PRF-19500
- Miniature hermetically sealed "pill" package
- Twice the power output of GaAs at same drive current
- "S" level screening available
- Mechanically and spectrally matched to OP600 phototransistors



Description:

Each **OP223 (TX)** and **OP224 (S, TX, TXV)** device is an 890 nm high reliability gallium aluminum arsenide infrared emitting diode that is mounted in a miniature hermetically sealed "pill" type package which can be directly mounted to PCBs. The gallium aluminum arsenide feature provides twice the radiated output of gallium arsenide at the same forward current.

After electrical testing by manufacturing, devices are processed to OPTEK's 100 percent screening program, which is patterned after MIL-PRF-19500. With a wavelength centered at 890 nm, the *OP223 (TXV) and OP224 (S, TX, TXV)*.

TX and TXV devices are processed to OPTEK's military screening program patterned after MIL-PRF-19500. S devices are processed to OPTEK's military screening program patterned after MIL-STD-883.

Please refer to Application Bulletins 208 and 210 for additional design information and reliability (degradation) data.

Contact your local representative or OPTEK for more information.

Applications:

- Non-contact reflective object sensor
- Assembly line automation
- Machine automation
- Machine safety
- End of travel sensor
- Door sensor

Part Number	LED Peak Wavelength	Output Power Minimum	Total Beam Angle	Lead Length
OP223TX	890 nm	1.00 mW/cm ²	24°	N/A
OP224S				
OP224TX				
OP224TXV				



Pin #	LED	Sensor
1	Anode	Collector
2	Cathode	Emitter

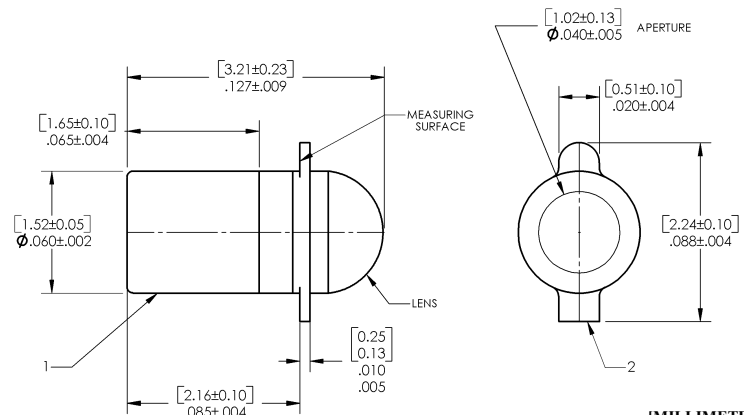

DIMENSIONS ARE IN: [MILLIMETERS]
INCHES

General Note

TT Electronics reserves the right to make changes in product specification without notice or liability. All information is subject to TT Electronics' own data and is considered accurate at time of going to print.

TT Electronics | OPTEK Technology, Inc.
1645 Wallace Drive, Carrollton, TX 75006 | Ph: +1 972 323 2200
sensors@ttelelectronics.com | www.ttelelectronics.com

Hi-Reliability GaAlAs Infrared Emitting Diode

OP223, OP224 (TX, TXV), OP224 (S)



Electrical Specifications

Absolute Maximum Ratings ($T_A = 25^\circ\text{C}$ unless otherwise noted)

Storage Temperature Range	-65° C to +150° C
Operating Temperature Range	-55° C to +125° C
Lead Soldering Temperature [1/16 inch (1.6 mm) from case for 5 seconds with soldering iron] ⁽¹⁾	260° C
Reverse Voltage	2.0 V
Continuous Forward Current	100 mA
Power Dissipation ⁽²⁾	100 mW

Notes:

1. No clean or low solids. RMA flux is recommended. Duration can be extended to 10 seconds maximum when flow soldering.
2. Derate linearly 1.00 mW/° C above 25° C.

Electrical Characteristics ($T_A = 25^\circ\text{C}$ unless otherwise noted)

SYMBOL	PARAMETER	MIN	TYP	MAX	UNITS	TEST CONDITIONS
--------	-----------	-----	-----	-----	-------	-----------------

Input Diode

SYMBOL	PARAMETER	MIN	TYP	MAX	UNITS	TEST CONDITIONS
E_E (APT)	Radiant Power Output OP223 (TX) OP224 (S, TX, TXV)	1.00 1.50	- -	- -	mW	$I_F = 50\text{ mA}$ $I_F = 50\text{ mA}$
V_F	Forward Voltage	0.80	-	1.80	V	$I_F = 50\text{ mA}$
I_R	Reverse Current	-	-	100	μA	$V_R = 2.0\text{ V}$
λ_P	Wavelength at Peak Emission	-	890	-	nm	$I_F = 50\text{ mA}$
B	Spectral Bandwidth between Half Power Points	-	80	-	nm	$I_F = 50\text{ mA}$
$\Delta\lambda_P/\Delta T$	Spectral Shift with Temperature	-	0.18	-	nm/°C	$I_F = \text{Constant}$
θ_{HP}	Emission Angle at Half Power Points	-	18	-	Degree	$I_F = 50\text{ mA}$

General Note

TT Electronics reserves the right to make changes in product specification without notice or liability. All information is subject to TT Electronics' own data and is considered accurate at time of going to print.

TT Electronics | OPTEK Technology, Inc.
1645 Wallace Drive, Carrollton, TX 75006 | Ph: +1 972 323 2200
sensors@ttelelectronics.com | www.ttelelectronics.com

Hi-Reliability GaAlAs Infrared Emitting Diode

OP223, OP224 (TX, TXV), OP224 (S)



OP223 (TX), OP224 (S, TX, TXV)

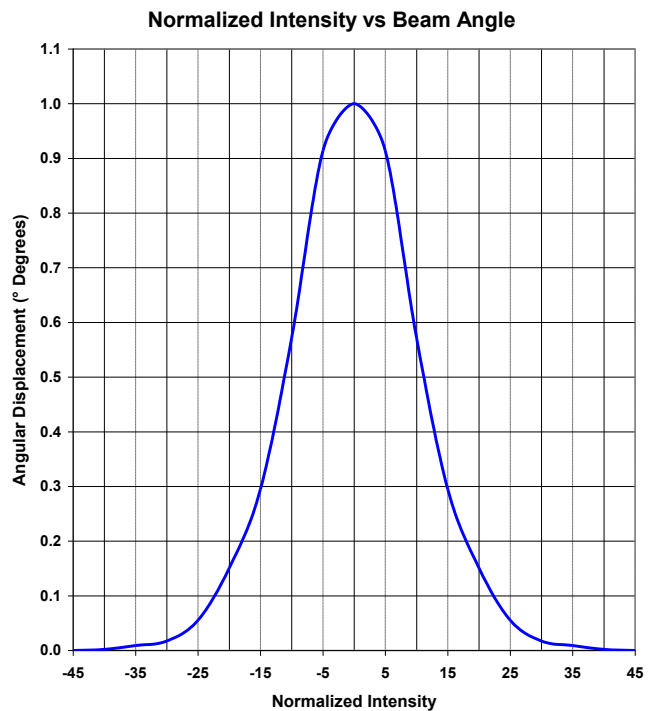
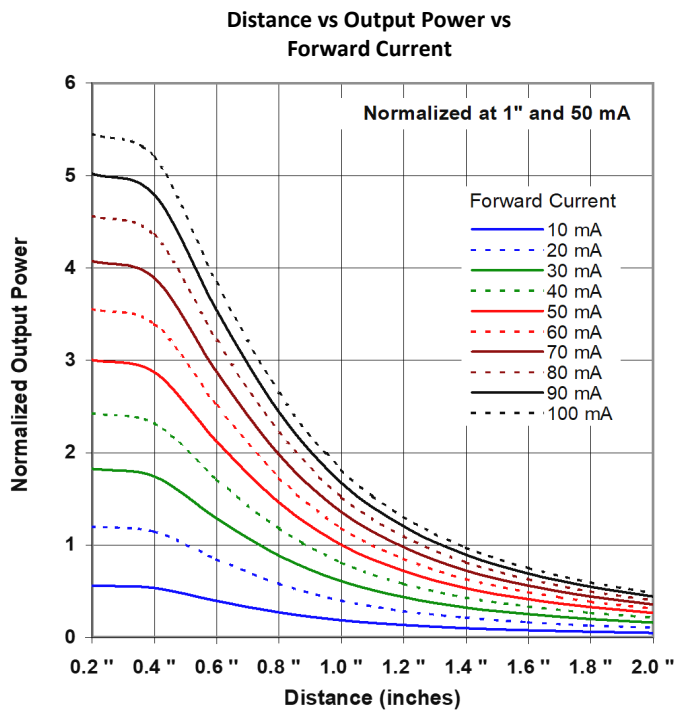
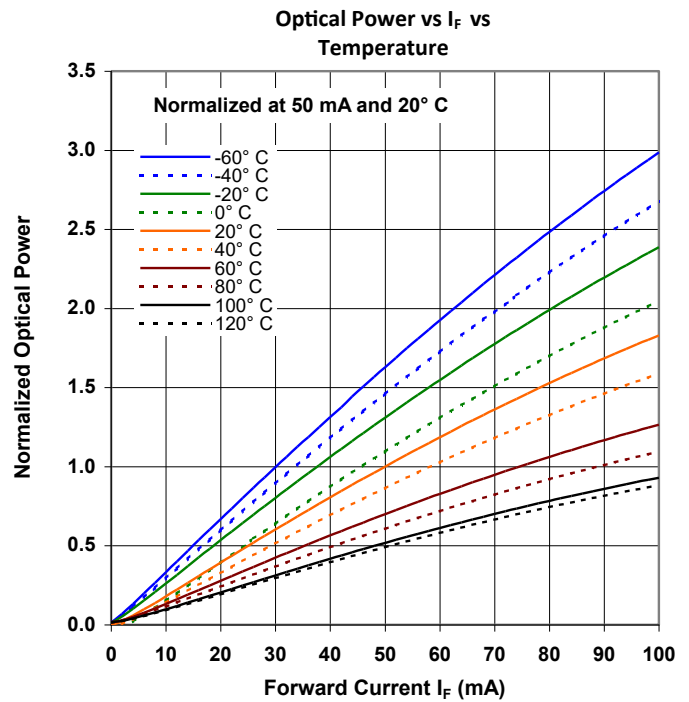
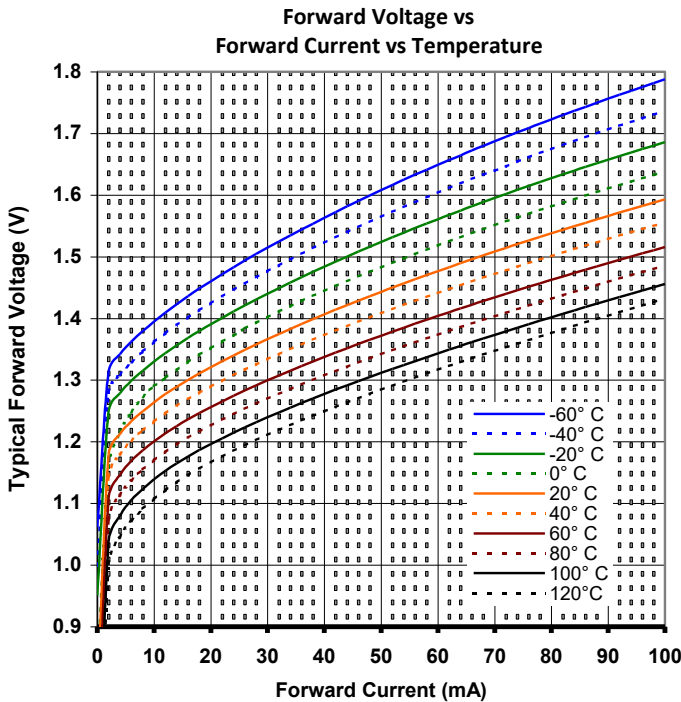

General Note
 TT Electronics reserves the right to make changes in product specification without notice or liability. All information is subject to TT Electronics' own data and is considered accurate at time of going to print.

TT Electronics | OPTEK Technology, Inc.
 1645 Wallace Drive, Carrollton, TX 75006 | Ph: +1 972 323 2200
 sensors@ttelelectronics.com | www.ttelelectronics.com

Компания «Life Electronics» занимается поставками электронных компонентов импортного и отечественного производства от производителей и со складов крупных дистрибьюторов Европы, Америки и Азии.

С конца 2013 года компания активно расширяет линейку поставок компонентов по направлению коаксиальный кабель, кварцевые генераторы и конденсаторы (керамические, пленочные, электролитические), за счёт заключения дистрибьюторских договоров

Мы предлагаем:

- Конкуренспособные цены и скидки постоянным клиентам.
- Специальные условия для постоянных клиентов.
- Подбор аналогов.
- Поставку компонентов в любых объемах, удовлетворяющих вашим потребностям.
- Приемлемые сроки поставки, возможна ускоренная поставка.
- Доставку товара в любую точку России и стран СНГ.
- Комплексную поставку.
- Работу по проектам и поставку образцов.
- Формирование склада под заказчика.
- Сертификаты соответствия на поставляемую продукцию (по желанию клиента).
- Тестирование поставляемой продукции.
- Поставку компонентов, требующих военную и космическую приемку.
- Входной контроль качества.
- Наличие сертификата ISO.

В составе нашей компании организован Конструкторский отдел, призванный помогать разработчикам, и инженерам.

Конструкторский отдел помогает осуществить:

- Регистрацию проекта у производителя компонентов.
- Техническую поддержку проекта.
- Защиту от снятия компонента с производства.
- Оценку стоимости проекта по компонентам.
- Изготовление тестовой платы монтаж и пусконаладочные работы.



Тел: +7 (812) 336 43 04 (многоканальный)

Email: org@lifeelectronics.ru