

## Current transformer - PACT RCP-4000A-UIRO-PT-D95 - 2906234

Please be informed that the data shown in this PDF Document is generated from our Online Catalog. Please find the complete data in the user's documentation. Our General Terms of Use for Downloads are valid (<http://phoenixcontact.com/download>)



Set consisting of a 4-way signal conditioner with push-in connection technology and a Rogowski coil 300 mm in length/95 mm in diameter for AC current measurement on busbars and power lines. The signal conditioner outputs 8 different standard signals on the output side and has one switching output.



### Key Commercial Data

Packing unit	1 pc
Weight per Piece (excluding packing)	440.0 g
Custom tariff number	85437090
Country of origin	Germany

### Technical data

#### Measuring transducer supply

Nominal supply voltage	24 V DC
Nominal supply voltage range	9.6 V DC ... 30 V DC
Power consumption	$\leq 1$ W (at $I_{OUT} = 20$ mA, 9.6 V DC, 600 $\Omega$ load)

#### Measuring coil input data

Frequency measuring range	40 Hz ... 20000 Hz
Position error	$< 1$ %
Linearity error	0.1 %

#### Measuring transducer input data

Measuring ranges (current)	100 A 250 A 400 A 630 A 1000 A 1500 A 2000 A 4000 A
Configurable/programmable	Via DIP switches

#### Measuring transducer signal input

Input signal (at 50 Hz)	100 mV (1000 A)
Input impedance	$> 100$ k $\Omega$

#### Measuring coil signal output

## Current transformer - PACT RCP-4000A-UIRO-PT-D95 - 2906234

### Technical data

#### Measuring coil signal output

Output signal (at 50 Hz)	100 mV (no load, at 1,000 A)
Output voltage (in no-load operation)	$V_{OUT} = M \cdot di/dt$
Output voltage (sinusoidal, in no-load operation)	100 mV ( $V_{OUT} = 2 \cdot \pi \cdot M \cdot f \cdot I$ (M = 0.318 $\mu$ H; example: At 50 Hz; I = 1,000 A))

#### Measuring transducer signal output

Current output signal	0 mA ... 20 mA (via DIP switch)
	4 mA ... 20 mA (via DIP switch)
	0 mA ... 10 mA (via DIP switch)
	2 mA ... 10 mA (via DIP switch)
	0 mA ... 21 mA (Can be set via software)
Voltage output signal	0 V ... 10 V (via DIP switch)
	2 V ... 10 V (via DIP switch)
	0 V ... 5 V (via DIP switch)
	1 V ... 5 V (via DIP switch)
	0 V ... 10.5 V (Can be set via software)
Load/output load current output	$\leq 600 \Omega$ (20 mA)

#### General data, measuring coil

Length of measuring coil	300 mm
Diameter of measuring coil	8.3 mm $\pm$ 0.2 mm
Length of signal cable	3000 mm
Conductor structure signal line	2x 0.22 mm (Signal (tinned))
	1x 0.22 mm (Shielding (tinned))
Coil material	Elastollan
Housing material	PC
Insulation	double insulation
Rated insulation voltage	1000 V AC (rms CAT III)
	600 V AC (rms CAT IV)
Test voltage	10.45 kV (DC / 1 min.)
Basic accuracy	$<\pm 0.21 \%$
UL, USA / Canada	UL 61010 Recognized

#### General data for measuring transducer

Maximum transmission error	$\leq 0.5 \%$ (From the range end value)
Frequency range	16 Hz ... 1000 Hz
Housing material	PBT
Degree of protection	IP20
Test voltage	3 kV (50 Hz, 1 min.)

# Current transformer - PACT RCP-4000A-UIRO-PT-D95 - 2906234

## Technical data

### General data for measuring transducer

UL, USA / Canada	UL 508 Listed
------------------	---------------

### General data

Standards/regulations	IEC 61010-1
	IEC 61010-2-032
Pollution degree	2
Overvoltage category	II
Typical measuring error	< 1 %

### Connection data

Connection name	Measuring transducer side
Conductor cross section flexible min.	0.2 mm <sup>2</sup>
Conductor cross section flexible max.	2.5 mm <sup>2</sup>
Conductor cross section solid min.	0.2 mm <sup>2</sup>
Conductor cross section solid max.	2.5 mm <sup>2</sup>
Conductor cross section AWG min.	26
Conductor cross section AWG max.	12
Screw thread	M3
Connection method	Push-in connection
Stripping length	10 mm

### Dimensions

Width	6.20 mm
Height	110.50 mm
Depth	120.50 mm

### Ambient conditions

Ambient temperature (operation)	-30 °C ... 80 °C (Measuring coil)
	-40 °C ... 70 °C (Measuring transducer)
Ambient temperature (storage/transport)	-40 °C ... 80 °C (Measuring coil)
	-40 °C ... 85 °C (Measuring transducer)
Maximum altitude	> 4000 m
Measuring coil degree of protection	IP67 (not assessed by UL)

## Classifications

### eCl@ss

eCl@ss 5.1	27200303
eCl@ss 6.0	27200303

# Current transformer - PACT RCP-4000A-UIRO-PT-D95 - 2906234

## Classifications

ETIM

ETIM 4.0	EC002475
ETIM 5.0	EC002475

## Drawings

Block diagram

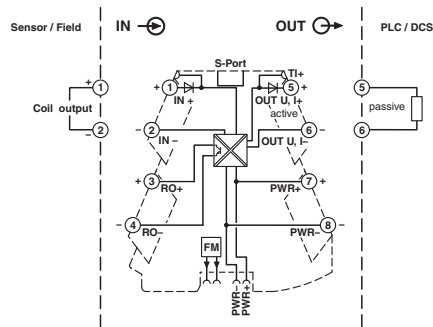

Компания «Life Electronics» занимается поставками электронных компонентов импортного и отечественного производства от производителей и со складов крупных дистрибьюторов Европы, Америки и Азии.

С конца 2013 года компания активно расширяет линейку поставок компонентов по направлению коаксиальный кабель, кварцевые генераторы и конденсаторы (керамические, пленочные, электролитические), за счёт заключения дистрибьюторских договоров

Мы предлагаем:

- Конкурентоспособные цены и скидки постоянным клиентам.
- Специальные условия для постоянных клиентов.
- Подбор аналогов.
- Поставку компонентов в любых объемах, удовлетворяющих вашим потребностям.
- Приемлемые сроки поставки, возможна ускоренная поставка.
- Доставку товара в любую точку России и стран СНГ.
- Комплексную поставку.
- Работу по проектам и поставку образцов.
- Формирование склада под заказчика.
- Сертификаты соответствия на поставляемую продукцию (по желанию клиента).
- Тестирование поставляемой продукции.
- Поставку компонентов, требующих военную и космическую приемку.
- Входной контроль качества.
- Наличие сертификата ISO.

В составе нашей компании организован Конструкторский отдел, призванный помогать разработчикам, и инженерам.

Конструкторский отдел помогает осуществить:

- Регистрацию проекта у производителя компонентов.
- Техническую поддержку проекта.
- Защиту от снятия компонента с производства.
- Оценку стоимости проекта по компонентам.
- Изготовление тестовой платы монтаж и пусконаладочные работы.



Тел: +7 (812) 336 43 04 (многоканальный)

Email: [org@lifeelectronics.ru](mailto:org@lifeelectronics.ru)