

Fixed Code Encoder

FEATURES

Operating

- 2 Programmable 32-bit Serial Numbers
- 10-bit Serial Number
- 66-bit Transmission Code Length
- Nonvolatile 16-bit Counter
- 3.5V -13.3V Operation
- 3 Inputs, 7 Functions Available
- Selectable Baud Rate
- Automatic Code Word Completion
- Battery Low Signal Transmitted to Receiver

Other

- Pinout Compatible With Most KEELOQ® Encoders
- Simple Programming Interface
- On-chip EEPROM
- On-chip Oscillator and Timing Components
- Button Inputs Have Internal Pull-down Resistors
- Minimum External Components Required

Typical Applications

The HCS101 is ideal for remote control applications. These applications include:

- Low-end Automotive Alarm Systems
- Low-end Automotive Immobilizers
- Gate and Garage Door Openers
- Identity Tokens
- Low-end Burglar Alarm Systems
- Fan and Lighting Controls
- Toys

DESCRIPTION

The HCS101 from Microchip Technology Inc. is a fixed code encoder designed for remote control systems. It provides a small package outline and low cost to make this device a perfect solution for unidirectional remote control systems.

It is pin compatible with Microchip's HCS201 Code Hopping Encoder allowing easy upgrading to a more secure remote keyless entry (RKE) system.

The 8-pin HCS101 operates over a wide voltage range of 3.5V to 13.3V and has three button inputs allowing the system designer the freedom to utilize up to 7 functions. The only components required for device operation are the buttons and RF circuitry, allowing a very low system cost.

PACKAGE TYPES

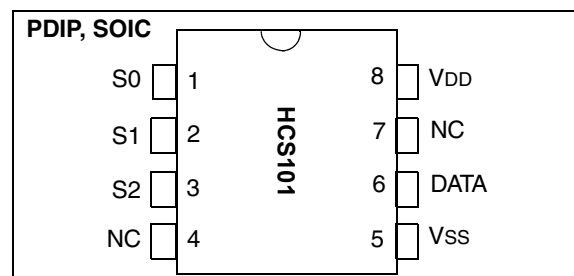

HCS101 BLOCK DIAGRAM

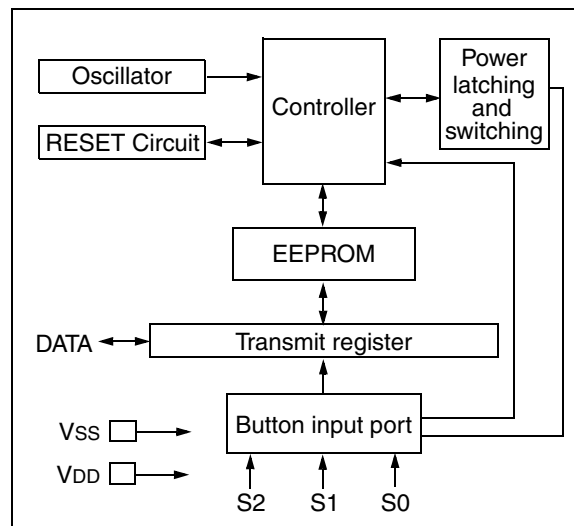

1.0 SYSTEM OVERVIEW

As indicated in the block diagram in Figure 1-1, the HCS101 has a small EEPROM array, which must be loaded with several parameters before use. These parameters include:

- Two 32-bit serial numbers
- 16-bit counter value
- Additional 10-bit serial number
- Configuration data

The EEPROM data for each transmitter is programmed by the manufacturer at the time of production.

Any type of controller may be used as a receiver, but it is typically a microcontroller with compatible firmware that allows the receiver to operate in conjunction with a transmitter, based on the HCS101.

FIGURE 1-1: BASIC OPERATION OF TRANSMITTER ENCODER

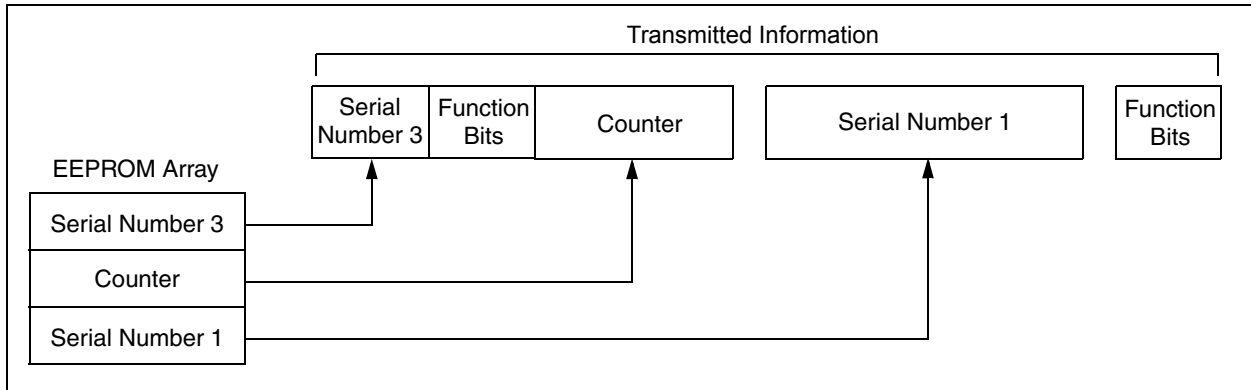

2.0 DEVICE OPERATION

As shown in the typical application circuits in Figure 2-1, the HCS101 is easy to use. It requires only the addition of buttons and RF circuitry for use as the transmitter in your application. A description of each pin is given in Table 2-1.

FIGURE 2-1: TYPICAL CIRCUITS

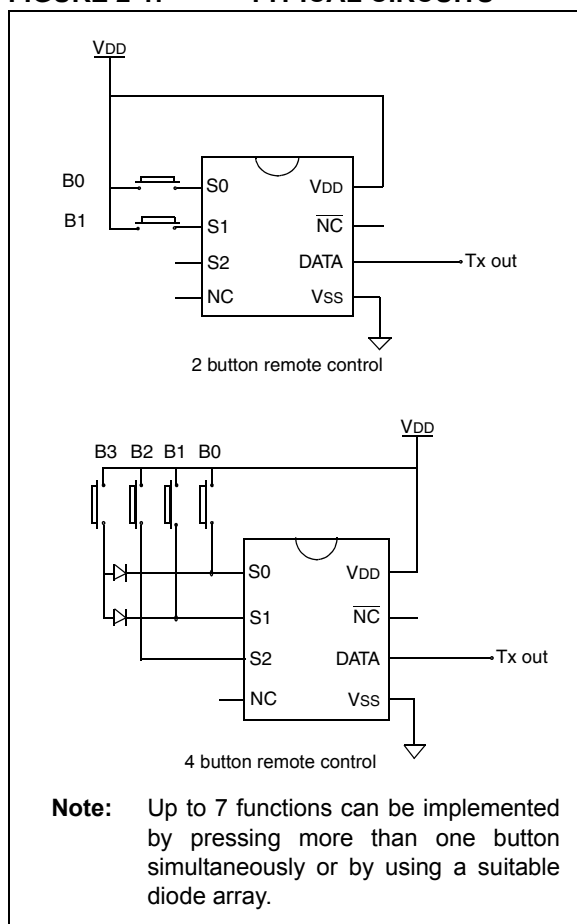

TABLE 2-1: PIN DESCRIPTIONS

Name	Pin Number	Description
S0	1	Switch input 0
S1	2	Switch input 1
S2	3	Switch input 2/Clock pin for Programming mode
NC	4	No connection
Vss	5	Ground reference connection
DATA	6	Pulse Width Modulation (PWM) output pin/Data pin for Programming mode
NC	7	No connection
VDD	8	Positive supply voltage connection

The HCS101 will wake-up upon detecting a switch closure and then delay for a debounce delay (T_{DB}) as shown in Figure 2-2. The device will then update the 16-bit counter before it loads the transmit register. The data is then transmitted serially on the DATA pin in Pulse Width Modulation (PWM) format.

If additional buttons are pressed during a transmission, the current transmission is terminated. The HCS101 restarts and the new transmission will contain the latest button information. When all buttons are released, the device completes the current code word and then powers down. Released buttons do not terminate and/or restart transmissions.

FIGURE 2-2: ENCODER OPERATION

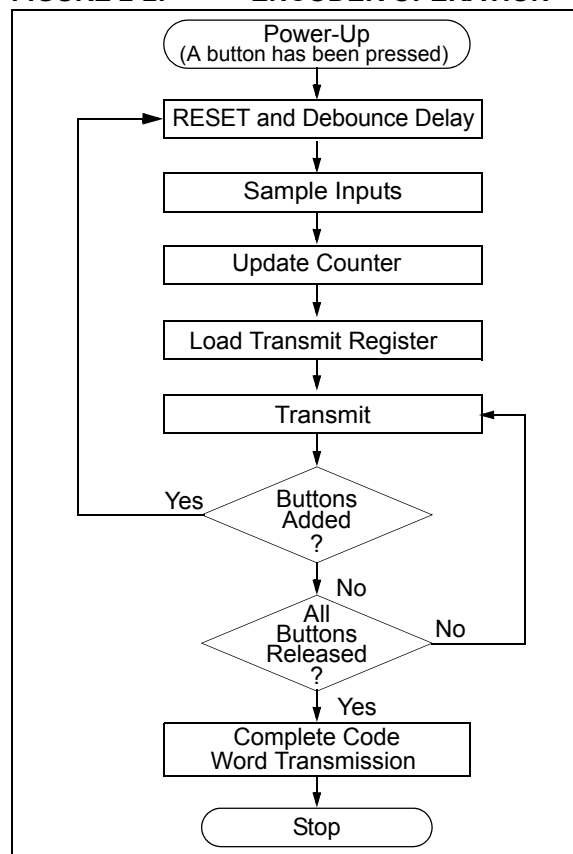

3.0 TRANSMITTED WORD

3.1 Transmission Format (PWM Mode)

The HCS101 transmission is made up of several code words as shown in Figure 3-1. Each code word starts with a preamble and a header, followed by the data. The code word is followed by a guard period before the next code word begins. The same code word is transmitted as long as the button is pressed. Refer to Table 7-3 for transmission timing requirements.

3.2 Code Word Organization

The HCS101 transmits a 66-bit code word. The 66-bit word is constructed from the serial numbers, counter and function information. The code word format is shown in Figure 3-2.

Under normal conditions, serial number 1 is transmitted with the counter and serial number 3. If all the buttons are pressed, serial number 2 is transmitted in place of the counter and serial number 3.

FIGURE 3-1: CODE WORD TRANSMISSION FORMAT

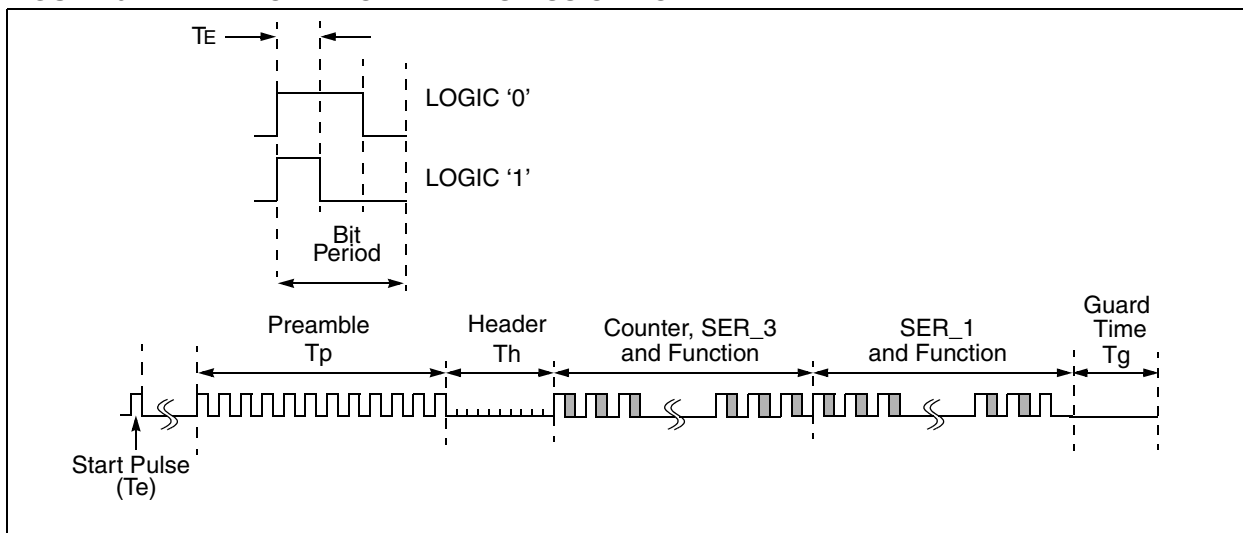
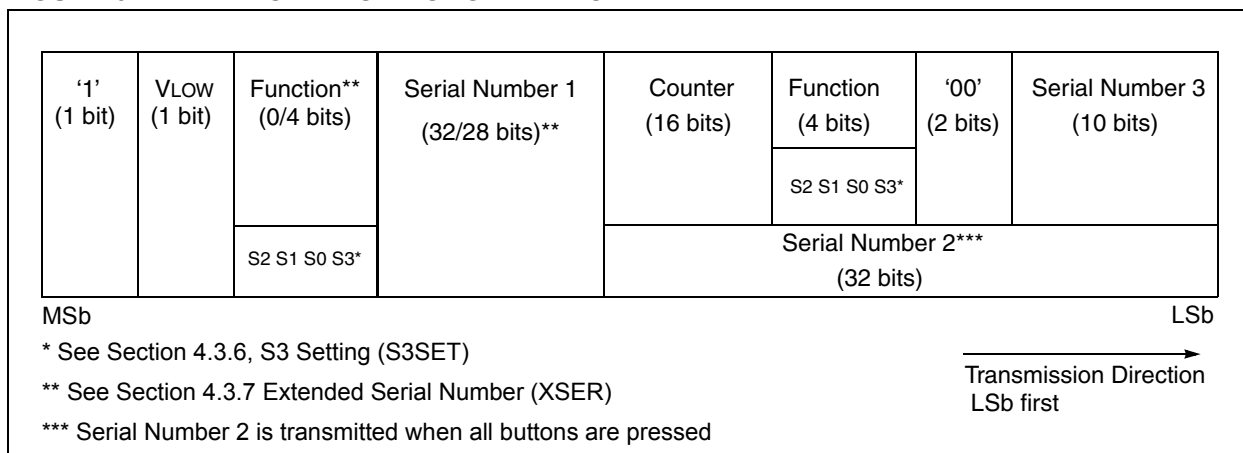

FIGURE 3-2: CODE WORD ORGANIZATION



4.0 EEPROM MEMORY ORGANIZATION

The HCS101 contains 192 bits (12 x 16-bit words) of EEPROM memory as shown in Table 4-1. Further descriptions of the memory array are given in the following sections.

TABLE 4-1: EEPROM MEMORY MAP

WORD ADDRESS	MNEMONIC	DESCRIPTION
0	RESERVED	Set to 0000H
1	RESERVED	Set to 0000H
2	RESERVED	Set to 0000H
3	RESERVED	Set to 0000H
4	CNTR	Counter
5	RESERVED	Set to 0000H
6	SER_1	Device Serial Number 1 (word 0) 16 LSB's
7	SER_1	Device Serial Number 1 (word 1) 16 MSB's
8	SER_2	Device Serial Number 2 (word 0) 16 LSB's
9	SER_2	Device Serial Number 2 (word 1) 16 MSB's
10	SER_3	Device Serial Number 3
11	CONFIG	Config Word

4.1 CNTR (Counter)

This is the 16-bit gray code counter value that can be used to track the number of times a transmitter has been activated.

4.2 SER_1, SER_2, SER_3 (Encoder Serial Number)

SER_1, and SER_2 are the 32-bit device serial numbers. SER_3 is an additional 10-bit serial number transmitted with every transmission. The most significant 6 bits of the 16-bit SER_3 word are reserved and should be set to zero.

4.3 Configuration Word

The configuration word is a 16-bit word stored in the EEPROM array that is used by the device to store the status configuration options. Further explanations of each of the bits are described in the following sections.

TABLE 4-2: CONFIGURATION WORD

Bit Number	Bit Name
0	OSC0
1	OSC1
2	OSC2
3	OSC3
4	VLOWS
5	BRS
6	MTX4
7	TXEN
8	S3SET
9	XSER
10	RESERVED
11	RESERVED
12	RESERVED
13	RESERVED
14	RESERVED
15	RESERVED

4.3.1 OSCILLATOR TUNING BITS (OSC0 TO OSC3)

These bits are used to tune the nominal frequency of the HCS101 to within $\pm 10\%$ of its nominal value over temperature and voltage.

4.3.2 LOW VOLTAGE TRIP POINT SELECT (VLOWS)

The low voltage trip point select bit (VLOWS) and the S3 setting bit (S3SET) are used to determine the voltage level for the low voltage detector.

VLOWS	S3SET*	Trip Point
0	0	4.4
0	1	4.4
1	0	9
1	1	6.75

* See also Section 4.3.6

4.3.3 BAUD RATE SELECT BITS (BRS)

BRS selects the speed of transmission and the code word blanking. Table 4-3 shows how the bit is used to select the different baud rates and Section 5.2 provides a detailed explanation of code word blanking.

TABLE 4-3: BAUD RATE SELECT

BRS	Basic Pulse Element	Code Words Transmitted
0	400 μ s	All
1	200 μ s	1 out of 2

4.3.4 MINIMUM FOUR TRANSMISSIONS (MTX4)

If this bit is cleared, at least one code word is completed when the HCS101 is activated. If this bit is set, at least four complete code words are transmitted.

4.3.5 TRANSMIT PULSE ENABLE (TXEN)

If this bit is cleared, no start pulse occurs before a transmission. If the bit is set, a start pulse (1 TE long) is transmitted before the first code word's preamble.

4.3.6 S3 SETTING (S3SET)

This bit determines the value of S3 in the function code during a transmission and the high trip point selected by V_{LOWS} in Section 4.3.2. If this bit is cleared, S3 mirrors S2 during a transmission. If the S3SET bit is set, S3 in the function code is always set, independent of the value of S2.

4.3.7 EXTENDED SERIAL NUMBER (XSER)

If this bit is cleared, the most significant four bits of the 32-bit Serial Number 1 are replaced with the function code. If this bit is set, the full 32-bit Serial Number 1 is transmitted.

5.0 SPECIAL FEATURES

5.1 Code Word Completion

Code word completion is an automatic feature that ensures the entire code word is transmitted, even if the button is released before the transmission is complete. If the button is held down beyond the time for one code word, multiple code words will result. If another button is activated during a transmission, the active transmission will be aborted and a new transmission will begin using the new button information.

5.2 Blank Alternate Code Word

Federal Communications Commission (FCC) Rules, Part 15 specify the limits on fundamental power and harmonics that can be transmitted. Power is calculated on the worst case average power transmitted in a 100 ms window. It is therefore advantageous to minimize the duty cycle of the transmission by minimizing the duty cycle of the individual bits and by blanking out consecutive words. The transmission duty cycle can be lowered by setting BRS. This reduces the average power transmitted and hence, assists in FCC approval of a transmitter device. Shortening the code word length and transmitting only every other code word (Figure 5-1) also may allow a higher amplitude transmission for greater range.

5.3 Auto-Shutoff

The auto-shutoff function automatically stops the device from transmitting if a button inadvertently gets pressed for longer than the time-out period, T_{TO}. This will prevent the device from draining the battery if a button gets pressed while the transmitter is in a pocket or purse.

5.4 V_{LOW}: Voltage LOW Indicator

The V_{LOW} bit is included in every transmission and will be transmitted as a one if the operating voltage has dropped below the low voltage trip point. Refer to Figure 3-2. The trip point is selectable based on the battery voltage being used. See Section 4.3.2 for a description of how the low voltage select option is set.

FIGURE 5-1: CODE WORD TRANSMISSIONS

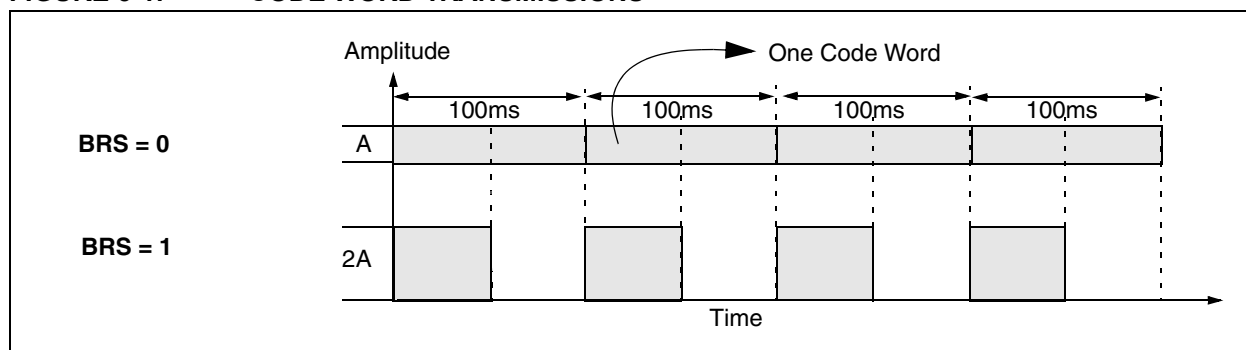

6.0 PROGRAMMING THE HCS101

When using the HCS101 in a system, the user will have to program some parameters into the device, including the serial number and the counter, before it can be used. The programming cycle allows the user to input a 192-bit serial data stream which is then stored internally in EEPROM. Programming will be initiated by forcing the DATA line high after the S2 line has been held high for the appropriate length of time. Refer to Table 6-1 and Figure 6-1.

After the Program mode is entered, a delay must be provided to the device for the automatic bulk write cycle to complete. This will write all locations in the EEPROM to all zeros. The device can then be programmed by clocking in 16 bits at a time, using S2 as the clock line and DATA as the data in line. After each 16-bit word is loaded, a programming delay is required for the internal program cycle to complete. This delay can take up to T_{wc} .

The HCS101 will signal that the write is complete by sending out a train of ACK pulses, TACKH high, TACKL low on DATA. The ACK pulses will continue until S2 is dropped. These times can be used to calculate the oscillator calibration value. The first pulse's width should NOT be used for calibration.

At the end of the programming cycle, the device can be verified as shown in Figure 6-2 by reading back the EEPROM. Reading is done by clocking the S2 line and reading the data bits on the DATA pin. **A verify operation can only be done once, immediately following the program cycle.**

Note: To ensure that the device does not accidentally enter Programming mode, DATA should never be pulled high by the circuit connected to it. Special care should be taken when driving PNP RF transistors.

FIGURE 6-1: PROGRAMMING WAVEFORMS

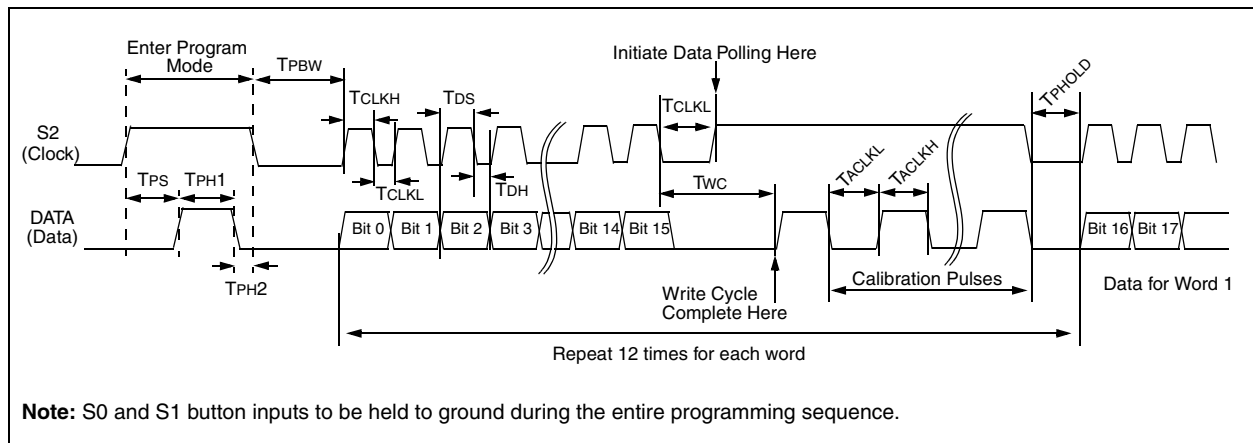

FIGURE 6-2: VERIFY WAVEFORMS

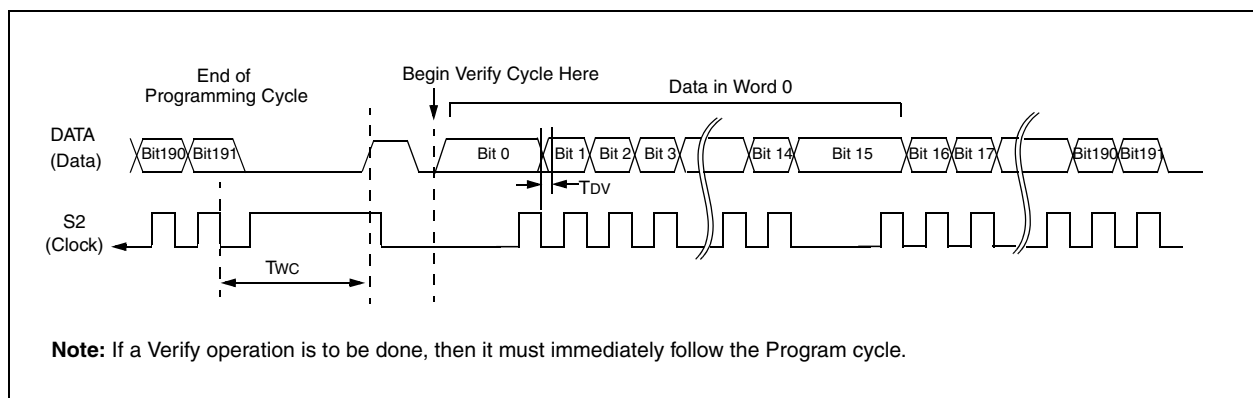

TABLE 6-1: PROGRAMMING/VERIFY TIMING REQUIREMENTS

VDD = 5.0V ± 10% 25° C ± 5°C				
Parameter	Symbol	Min.	Max.	Units
Program mode setup time	TPS	1.5	1.75	ms
Hold time 1	TPH1	4.5	—	ms
Hold time 2	TPH2	50	—	µs
Bulk Write time	TPBW	4.0	—	ms
Program delay time	T _{PROG}	4.0	—	ms
Program cycle time	TWC	50	—	ms
Clock low time	TCLKL	50	—	µs
Clock high time	TCLKH	50	—	µs
Data setup time	TDS	0	—	µs
Data hold time	TDH	30	—	µs
Data out valid time	TDV	—	30	µs
Hold time	TPHOLD	100	—	µs ⁽¹⁾
Acknowledge low time	TACKL	800	—	µs ⁽¹⁾
Acknowledge high time	TACKH	800	—	µs ⁽¹⁾

Note 1: Typical values - not tested in production

7.0 ELECTRICAL CHARACTERISTICS FOR HCS101

Absolute Maximum Ratings[†]

V _{DD} Supply voltage	-0.3 to 13.5 V
V _{IN} Input voltage	-0.3 to V _{DD} + 0.3 V
V _{OUT} Output voltage	-0.3 to V _{DD} + 0.3 V
I _{OUT} Max Output current	50 mA
T _{STG} Storage temperature (Note)	-55 to +125°C
T _{LSOL} Lead soldering temperature (Note)	300°C
V _{ESD} ESD rating	2000 V

[†] **NOTICE:** Stresses above those listed under “Absolute Maximum Ratings” may cause permanent damage to the device. This is a stress rating only and functional operation of the device at those or any other conditions above those indicated in the operation listings of this specification is not implied. Exposure to maximum rating conditions for extended periods may affect device reliability.

TABLE 7-1: DC CHARACTERISTICS

Commercial (C):T _{AMB} = 0°C to +70°C Industrial (I):T _{AMB} = -40°C to +85°C									
		3.5V < V _{DD} < 5.0V			5.0V < V _{DD} < 13.3V				
Parameter	Sym.	Min.	Typ ¹	Max.	Min.	Typ ¹	Max.	Unit	Conditions
Operating Current (avg) ⁽²⁾	I _{CC}		—	0.5		—	2	mA mA	
Standby Current	I _{CCS}		0.1	1.0		0.1	1.0	μA	
Auto-shutoff Current ^(3,4)	I _{CCS}		40	75		160	300	μA	
High Level Input Voltage	V _{IH}	0.55V _{DD}		V _{DD} +0.3	2.75		V _{DD} +0.3	V	
Low Level Input Voltage	V _{IL}	-0.3		0.15V _{DD}	-0.3		0.75	V	
High Level Output Voltage	V _{OH}	0.6V _{DD}			3.3			V V	I _{OH} = -1.0 mA V _{DD} = 3.5V I _{OH} = -2.0 mA V _{DD} = 10V
Low Level Output Voltage	V _{OL}			0.08V _{DD}			0.4	V V	I _{OL} = 1.0 mA V _{DD} = 3.5V I _{OL} = 2.0 mA V _{DD} = 10V
Pull-down Resistance; S0-S2	R _{SO-2}	40	60	80	40	60	80	kΩ	V _{DD} = 4.0V
Pull-down Resistance; DATA	R _{DATA}	80	120	160	80	120	160	kΩ	V _{DD} = 4.0V

Note 1: Typical values are at 25°C.

2: No load.

3: Auto-shutoff current specification does not include the current through the input pulldown resistors.

4: Auto-shutoff current is periodically sampled and not 100% tested.

FIGURE 7-1: POWER-UP AND TRANSMIT TIMING

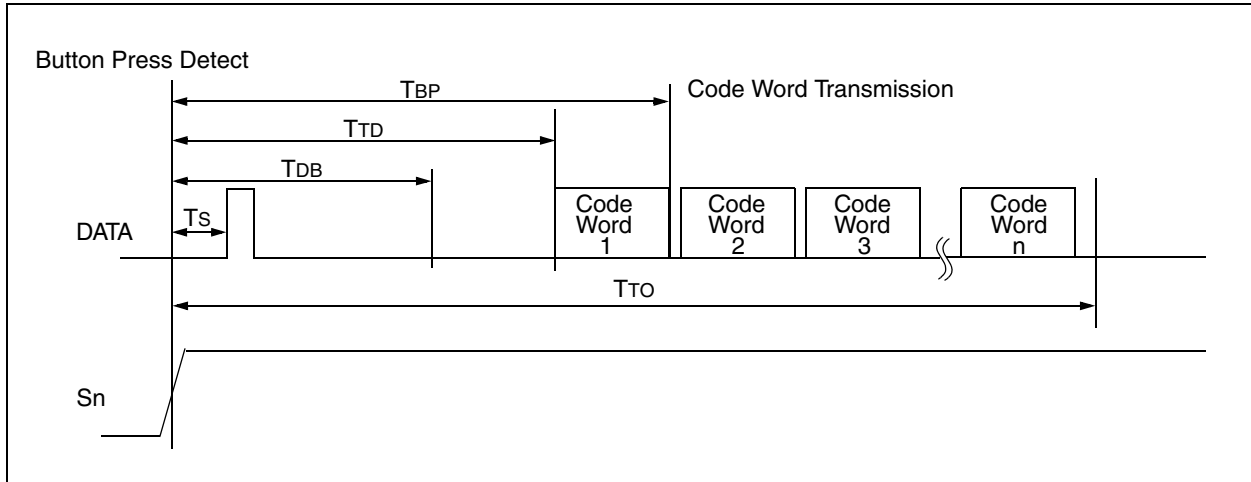

TABLE 7-2: POWER-UP AND TRANSMIT TIMING⁽²⁾

		Standard Operating Conditions (unless otherwise specified): Commercial (C): 0°C ≤ TA ≤ +70°C Industrial (I): -40°C ≤ TA ≤ +85°C				
Symbol	Parameters	Min.	Typ.	Max.	Units	Conditions
TBP	Time to second button press	10 + Code Word Time	—	26 + Code Word Time	ms	(Note 1)
TTD	Transmit delay from button detect	12	—	26	ms	
TDB	Debounce delay	6	—	20	ms	
TTo	Auto-shutoff time-out period	—	27	—	s	
Ts	Start pulse delay	—	4.5	—	ms	

Note 1: TBP is the time in which a second button can be pressed without completion of the first code word and the intention was to press the combination of buttons.

2: Typical values - not tested in production.

FIGURE 7-2: PREAMBLE/HEADER FORMAT

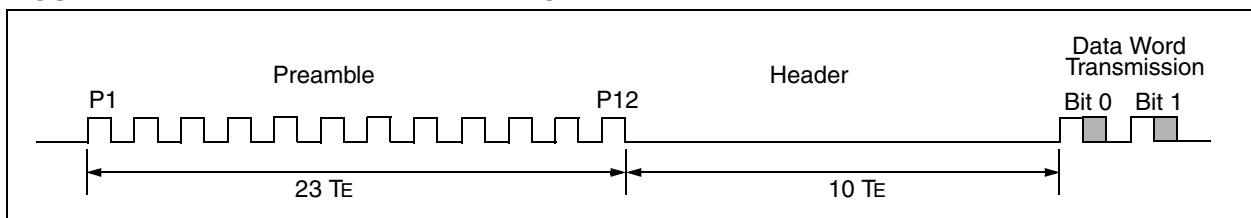

FIGURE 7-3: DATA WORD FORMAT (XSER = 0)

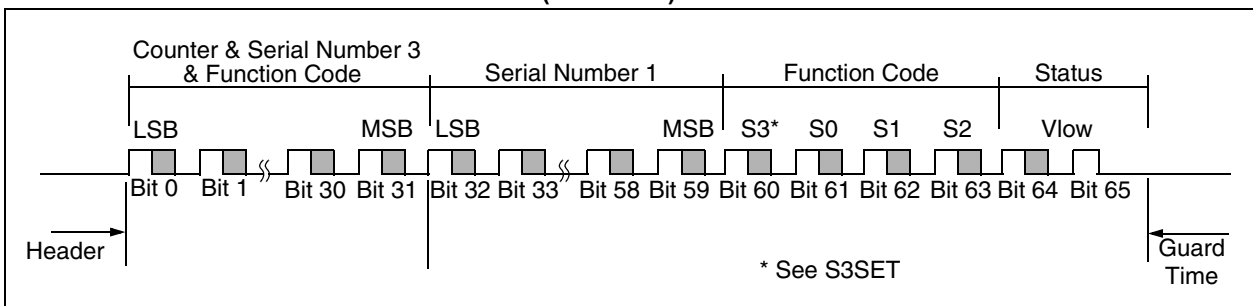

TABLE 7-3: CODE WORD TRANSMISSION TIMING REQUIREMENTS

VDD = +3.5 to 13.3V Commercial (C):TAMB = 0°C to +70°C Industrial (I):TAMB = -40°C to +85°C			Code Words Transmitted						Units
			All			1 out of 2			
Symbol	Characteristic	Number of TE	Min.	Typ.	Max.	Min.	Typ.	Max.	Units
TE	Basic pulse element	1	360	400	440	180	200	220	µs
TBP	PWM bit pulse width	3	—	3	—	—	3	—	ms
TP	Preamble duration	24	8.64	9.6	10.56	4.32	4.8	5.28	ms
TH	Header duration	10	3.6	4.0	4.4	1.8	2.0	2.2	ms
THOP	Hopping code duration	96	34.56	38.4	42.24	17.28	19.2	21.12	ms
TFIX	Fixed code duration	102	36.72	40.8	44.88	18.36	20.4	22.44	ms
TG	Guard Time	39	14.04	15.6	17.16	7.02	7.8	8.58	ms
—	Total Transmit Time	271	97.56	108.4	119.24	48.78	54.2	59.62	ms
—	PWM data rate	—	925	833	757	1851	1667	1515	bps

Note: The timing parameters are not tested but derived from the oscillator clock.

8.0 PACKAGING INFORMATION

8.1 Package Marking Information

8-Lead PDIP (300 mil)



8-Lead SOIC (150 mil)



Legend:	XX...X	Customer-specific information
	Y	Year code (last digit of calendar year)
	YY	Year code (last 2 digits of calendar year)
	WW	Week code (week of January 1 is week '01')
	NNN	Alphanumeric traceability code
	(e3)	Pb-free JEDEC designator for Matte Tin (Sn)
	*	This package is Pb-free. The Pb-free JEDEC designator (e3) can be found on the outer packaging for this package.

Note: In the event the full Microchip part number cannot be marked on one line, it will be carried over to the next line, thus limiting the number of available characters for customer-specific information.

8.2 Package Details

8-Lead Plastic Dual In-line (P) - 300 mil (PDIP)

8-Lead Plastic Dual In-Line (P) - 300 mil Body [PDIP]

Note: For the most current package drawings, please see the Microchip Packaging Specification located at <http://www.microchip.com/packaging>

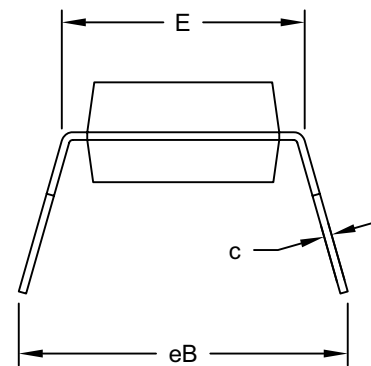
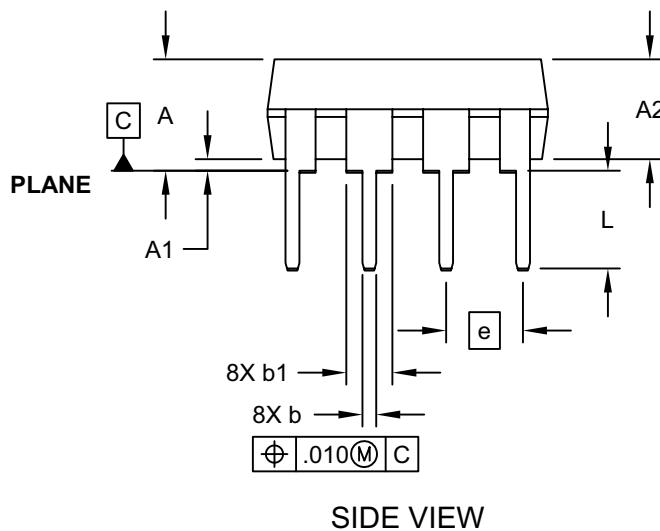
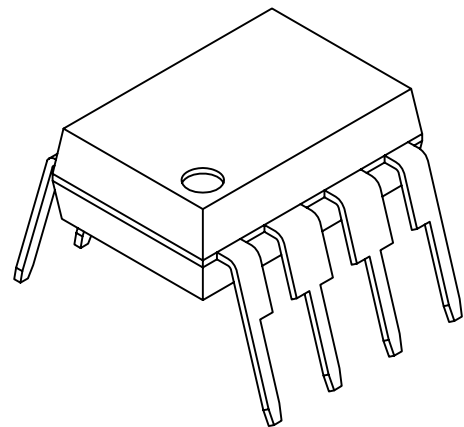
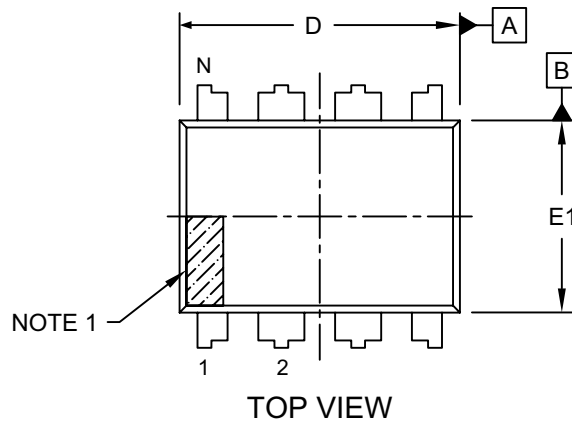

Microchip Technology Drawing No. C04-018D Sheet 1 of 2

8-Lead Plastic Dual In-Line (P) - 300 mil Body [PDIP]

Note: For the most current package drawings, please see the Microchip Packaging Specification located at <http://www.microchip.com/packaging>

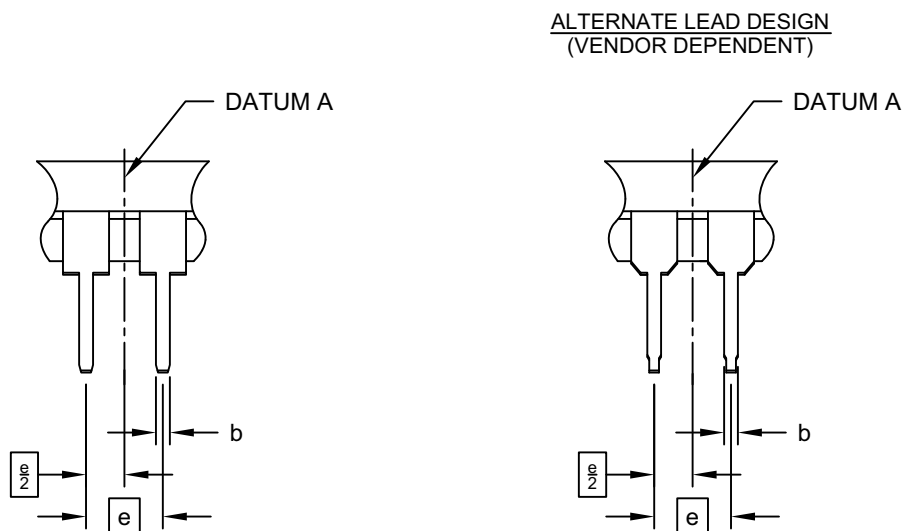

		Units	INCHES		
Dimension Limits			MIN	NOM	MAX
Number of Pins	N		8		
Pitch	e		.100 BSC		
Top to Seating Plane	A	-	-	-	.210
Molded Package Thickness	A2	.115	.130	.195	
Base to Seating Plane	A1	.015	-	-	
Shoulder to Shoulder Width	E	.290	.310	.325	
Molded Package Width	E1	.240	.250	.280	
Overall Length	D	.348	.365	.400	
Tip to Seating Plane	L	.115	.130	.150	
Lead Thickness	c	.008	.010	.015	
Upper Lead Width	b1	.040	.060	.070	
Lower Lead Width	b	.014	.018	.022	
Overall Row Spacing	§	eB	-	-	.430

Notes:

1. Pin 1 visual index feature may vary, but must be located within the hatched area.
2. § Significant Characteristic
3. Dimensions D and E1 do not include mold flash or protrusions. Mold flash or protrusions shall not exceed .010" per side.
4. Dimensioning and tolerancing per ASME Y14.5M

BSC: Basic Dimension. Theoretically exact value shown without tolerances.

Microchip Technology Drawing No. C04-018D Sheet 2 of 2

8-Lead Plastic Small Outline (SN) - Narrow, 150 mil (SOIC)

8-Lead Plastic Small Outline (SN) - Narrow, 3.90 mm (.150 In.) Body [SOIC]

Note: For the most current package drawings, please see the Microchip Packaging Specification located at <http://www.microchip.com/packaging>

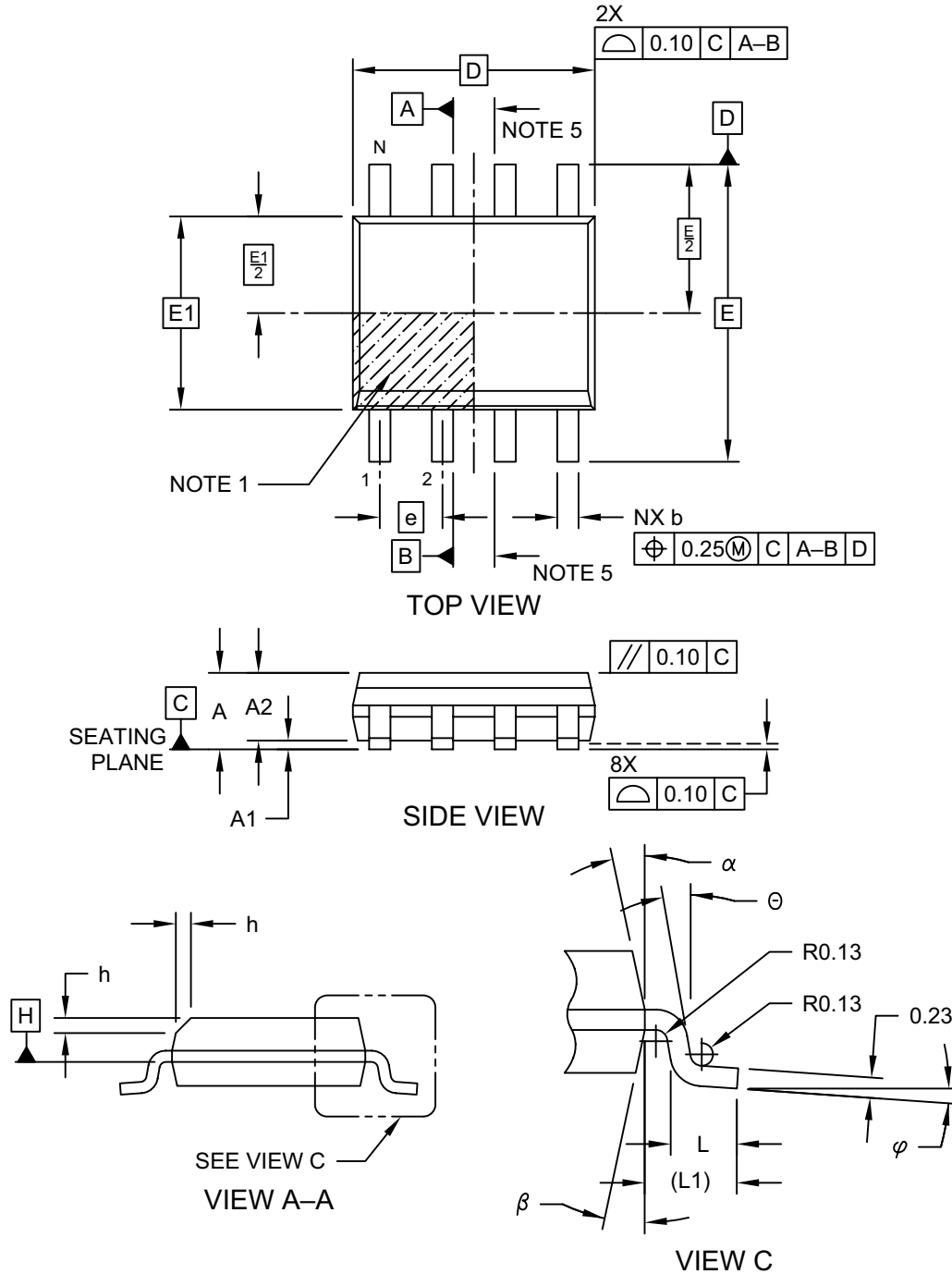

Microchip Technology Drawing No. C04-057-SN Rev D Sheet 1 of 2

8-Lead Plastic Small Outline (SN) - Narrow, 3.90 mm (.150 In.) Body [SOIC]

Note: For the most current package drawings, please see the Microchip Packaging Specification located at <http://www.microchip.com/packaging>

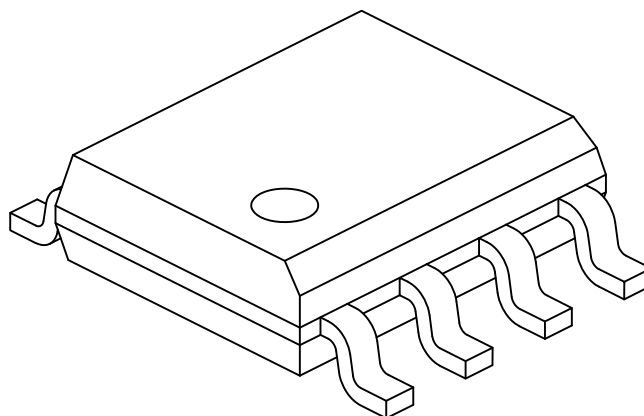

Dimension Limits	Units	MILLIMETERS		
		MIN	NOM	MAX
Number of Pins	N	8		
Pitch	e	1.27 BSC		
Overall Height	A	-	-	1.75
Molded Package Thickness	A2	1.25	-	-
Standoff §	A1	0.10	-	0.25
Overall Width	E	6.00 BSC		
Molded Package Width	E1	3.90 BSC		
Overall Length	D	4.90 BSC		
Chamfer (Optional)	h	0.25	-	0.50
Foot Length	L	0.40	-	1.27
Footprint	L1	1.04 REF		
Foot Angle	φ	0°	-	8°
Lead Thickness	c	0.17	-	0.25
Lead Width	b	0.31	-	0.51
Mold Draft Angle Top	α	5°	-	15°
Mold Draft Angle Bottom	β	5°	-	15°

Notes:

- Pin 1 visual index feature may vary, but must be located within the hatched area.
- § Significant Characteristic
- Dimensions D and E1 do not include mold flash or protrusions. Mold flash or protrusions shall not exceed 0.15mm per side.
- Dimensioning and tolerancing per ASME Y14.5M
 - BSC: Basic Dimension. Theoretically exact value shown without tolerances.
 - REF: Reference Dimension, usually without tolerance, for information purposes only.
- Datums A & B to be determined at Datum H.

Microchip Technology Drawing No. C04-057-SN Rev D Sheet 2 of 2

8-Lead Plastic Small Outline (SN) - Narrow, 3.90 mm Body [SOIC]

Note: For the most current package drawings, please see the Microchip Packaging Specification located at <http://www.microchip.com/packaging>

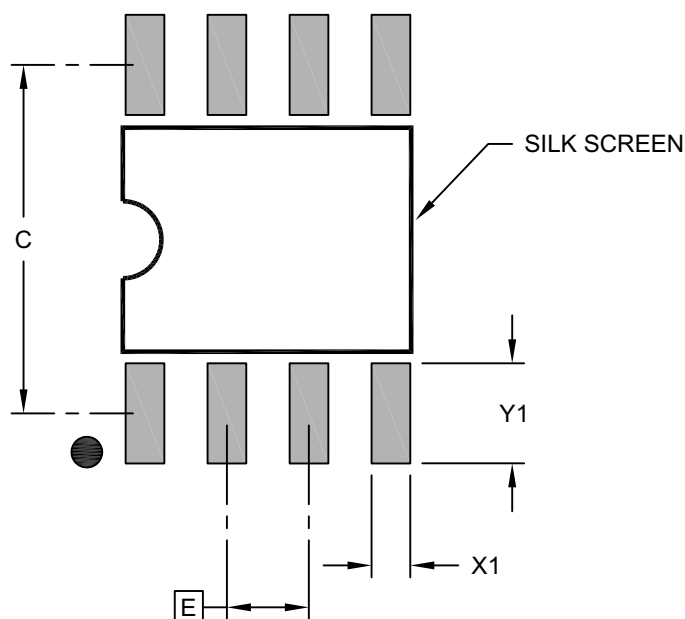

RECOMMENDED LAND PATTERN

Dimension Limits	Units	MILLIMETERS		
		MIN	NOM	MAX
Contact Pitch	E	1.27 BSC		
Contact Pad Spacing	C		5.40	
Contact Pad Width (X8)	X1			0.60
Contact Pad Length (X8)	Y1			1.55

Notes:

1. Dimensioning and tolerancing per ASME Y14.5M

BSC: Basic Dimension. Theoretically exact value shown without tolerances.

Microchip Technology Drawing C04-2057-SN Rev B

HCS101 PRODUCT IDENTIFICATION SYSTEM

To order or obtain information, e.g., on pricing or delivery, refer to the factory or the listed sales office.

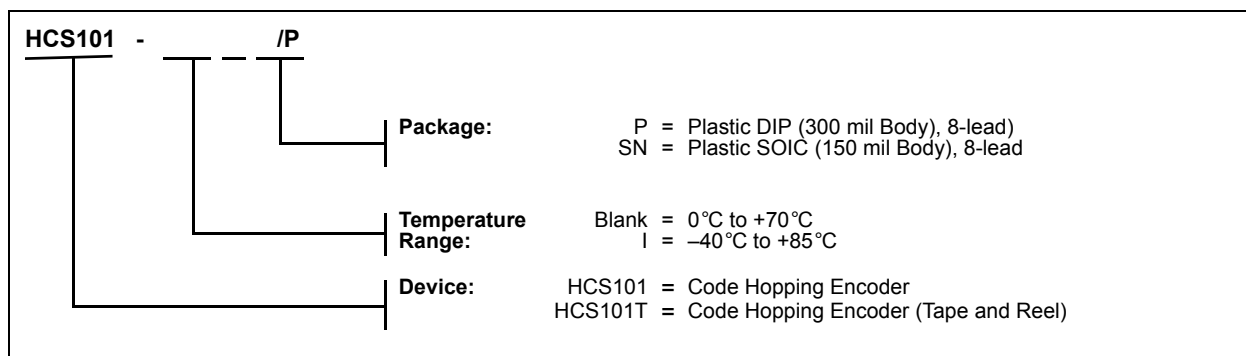

Sales and Support

Data Sheets

Products supported by a preliminary Data Sheet may have an errata sheet describing minor operational differences and recommended workarounds. To determine if an errata sheet exists for a particular device, please contact one of the following:

1. Your local Microchip sales office.
2. The Microchip Worldwide Web Site. (www.microchip.com)

APPENDIX A: REVISION HISTORY

Revision D (January 2013)

Added a note to each package outline drawing.

Revision E (October 2017)

Updated Table 6-1; Updated Package Drawings;
Replaced Reader Response page with On-Line
Customer Support page.

THE MICROCHIP WEB SITE

Microchip provides online support via our WWW site at www.microchip.com. This web site is used as a means to make files and information easily available to customers. Accessible by using your favorite Internet browser, the web site contains the following information:

- **Product Support** – Data sheets and errata, application notes and sample programs, design resources, user's guides and hardware support documents, latest software releases and archived software
- **General Technical Support** – Frequently Asked Questions (FAQ), technical support requests, online discussion groups, Microchip consultant program member listing
- **Business of Microchip** – Product selector and ordering guides, latest Microchip press releases, listing of seminars and events, listings of Microchip sales offices, distributors and factory representatives

CUSTOMER CHANGE NOTIFICATION SERVICE

Microchip's customer notification service helps keep customers current on Microchip products. Subscribers will receive e-mail notification whenever there are changes, updates, revisions or errata related to a specified product family or development tool of interest.

To register, access the Microchip web site at www.microchip.com. Under "Support", click on "Customer Change Notification" and follow the registration instructions.

CUSTOMER SUPPORT

Users of Microchip products can receive assistance through several channels:

- Distributor or Representative
- Local Sales Office
- Field Application Engineer (FAE)
- Technical Support

Customers should contact their distributor, representative or Field Application Engineer (FAE) for support. Local sales offices are also available to help customers. A listing of sales offices and locations is included in the back of this document.

Technical support is available through the web site at: <http://microchip.com/support>

Note the following details of the code protection feature on Microchip devices:

- Microchip products meet the specification contained in their particular Microchip Data Sheet.
- Microchip believes that its family of products is one of the most secure families of its kind on the market today, when used in the intended manner and under normal conditions.
- There are dishonest and possibly illegal methods used to breach the code protection feature. All of these methods, to our knowledge, require using the Microchip products in a manner outside the operating specifications contained in Microchip's Data Sheets. Most likely, the person doing so is engaged in theft of intellectual property.
- Microchip is willing to work with the customer who is concerned about the integrity of their code.
- Neither Microchip nor any other semiconductor manufacturer can guarantee the security of their code. Code protection does not mean that we are guaranteeing the product as “unbreakable.”

Code protection is constantly evolving. We at Microchip are committed to continuously improving the code protection features of our products. Attempts to break Microchip's code protection feature may be a violation of the Digital Millennium Copyright Act. If such acts allow unauthorized access to your software or other copyrighted work, you may have a right to sue for relief under that Act.

Information contained in this publication regarding device applications and the like is provided only for your convenience and may be superseded by updates. It is your responsibility to ensure that your application meets with your specifications. MICROCHIP MAKES NO REPRESENTATIONS OR WARRANTIES OF ANY KIND WHETHER EXPRESS OR IMPLIED, WRITTEN OR ORAL, STATUTORY OR OTHERWISE, RELATED TO THE INFORMATION, INCLUDING BUT NOT LIMITED TO ITS CONDITION, QUALITY, PERFORMANCE, MERCHANTABILITY OR FITNESS FOR PURPOSE. Microchip disclaims all liability arising from this information and its use. Use of Microchip devices in life support and/or safety applications is entirely at the buyer's risk, and the buyer agrees to defend, indemnify and hold harmless Microchip from any and all damages, claims, suits, or expenses resulting from such use. No licenses are conveyed, implicitly or otherwise, under any Microchip intellectual property rights unless otherwise stated.

Microchip received ISO/TS-16949:2009 certification for its worldwide headquarters, design and wafer fabrication facilities in Chandler and Tempe, Arizona; Gresham, Oregon and design centers in California and India. The Company's quality system processes and procedures are for its PIC® MCUs and dsPIC® DSCs, KEELOQ® code hopping devices, Serial EEPROMs, microperipherals, nonvolatile memory and analog products. In addition, Microchip's quality system for the design and manufacture of development systems is ISO 9001:2000 certified.

**QUALITY MANAGEMENT SYSTEM
CERTIFIED BY DNV
= ISO/TS 16949 =**

Trademarks

The Microchip name and logo, the Microchip logo, AnyRate, AVR, AVR logo, AVR Freaks, BeaconThings, BitCloud, chipKIT, chipKIT logo, CryptoMemory, CryptoRF, dsPIC, FlashFlex, flexPWR, Helder, JukeBlox, KEELOQ, KEELOQ logo, Kleer, LANCheck, LINK MD, maXStylus, maXTouch, MediaLB, megaAVR, MOST, MOST logo, MPLAB, OptoLyzer, PIC, picoPower, PICSTART, PIC32 logo, Prochip Designer, QTouch, RightTouch, SAM-BA, SpyNIC, SST, SST Logo, SuperFlash, tinyAVR, UNI/O, and XMEGA are registered trademarks of Microchip Technology Incorporated in the U.S.A. and other countries.

ClockWorks, The Embedded Control Solutions Company, EtherSynch, Hyper Speed Control, HyperLight Load, IntelliMOS, mTouch, Precision Edge, and Quiet-Wire are registered trademarks of Microchip Technology Incorporated in the U.S.A.

Adjacent Key Suppression, AKS, Analog-for-the-Digital Age, Any Capacitor, AnyIn, AnyOut, BodyCom, CodeGuard, CryptoAuthentication, CryptoCompanion, CryptoController, dsPICDEM, dsPICDEM.net, Dynamic Average Matching, DAM, ECAN, EtherGREEN, In-Circuit Serial Programming, ICSP, Inter-Chip Connectivity, JitterBlocker, KleerNet, KleerNet logo, Mindi, MiWi, motorBench, MPASM, MPF, MPLAB Certified logo, MPLIB, MPLINK, MultiTRAK, NetDetach, Omniscient Code Generation, PICDEM, PICDEM.net, PICKit, PICtail, PureSilicon, QMatrix, RightTouch logo, REAL ICE, Ripple Blocker, SAM-ICE, Serial Quad I/O, SMART-I.S., SQI, SuperSwitcher, SuperSwitcher II, Total Endurance, TSHARC, USBCheck, VariSense, ViewSpan, WiperLock, Wireless DNA, and ZENA are trademarks of Microchip Technology Incorporated in the U.S.A. and other countries.

SQTP is a service mark of Microchip Technology Incorporated in the U.S.A.

Silicon Storage Technology is a registered trademark of Microchip Technology Inc. in other countries.

GestIC is a registered trademark of Microchip Technology Germany II GmbH & Co. KG, a subsidiary of Microchip Technology Inc., in other countries.

All other trademarks mentioned herein are property of their respective companies.

© 1999-2017, Microchip Technology Incorporated, All Rights Reserved.

ISBN: 978-1-5224-2325-6



MICROCHIP

Worldwide Sales and Service

AMERICAS

Corporate Office

2355 West Chandler Blvd.
Chandler, AZ 85224-6199

Tel: 480-792-7200

Fax: 480-792-7277

Technical Support:

<http://www.microchip.com/support>

Web Address:

www.microchip.com

Atlanta

Duluth, GA

Tel: 678-957-9614

Fax: 678-957-1455

Austin, TX

Tel: 512-257-3370

Boston

Westborough, MA

Tel: 774-760-0087

Fax: 774-760-0088

Chicago

Itasca, IL

Tel: 630-285-0071

Fax: 630-285-0075

Dallas

Addison, TX

Tel: 972-818-7423

Fax: 972-818-2924

Detroit

Novi, MI

Tel: 248-848-4000

Houston, TX

Tel: 281-894-5983

Indianapolis

Noblesville, IN

Tel: 317-773-8323

Fax: 317-773-5453

Tel: 317-536-2380

Los Angeles

Mission Viejo, CA

Tel: 949-462-9523

Fax: 949-462-9608

Tel: 951-273-7800

Raleigh, NC

Tel: 919-844-7510

New York, NY

Tel: 631-435-6000

San Jose, CA

Tel: 408-735-9110

Tel: 408-436-4270

Canada - Toronto

Tel: 905-695-1980

Fax: 905-695-2078

ASIA/PACIFIC

Asia Pacific Office

Suites 3707-14, 37th Floor
Tower 6, The Gateway
Harbour City, Kowloon

Hong Kong

Tel: 852-2943-5100

Fax: 852-2401-3431

Australia - Sydney

Tel: 61-2-9868-6733

Fax: 61-2-9868-6755

China - Beijing

Tel: 86-10-8569-7000

Fax: 86-10-8528-2104

China - Chengdu

Tel: 86-28-8665-5511

Fax: 86-28-8665-7889

China - Chongqing

Tel: 86-23-8980-9588

Fax: 86-23-8980-9500

China - Dongguan

Tel: 86-769-8702-9880

China - Guangzhou

Tel: 86-20-8755-8029

China - Hangzhou

Tel: 86-571-8792-8115

Fax: 86-571-8792-8116

China - Hong Kong SAR

Tel: 852-2943-5100

Fax: 852-2401-3431

China - Nanjing

Tel: 86-25-8473-2460

Fax: 86-25-8473-2470

China - Qingdao

Tel: 86-532-8502-7355

Fax: 86-532-8502-7205

China - Shanghai

Tel: 86-21-3326-8000

Fax: 86-21-3326-8021

China - Shenyang

Tel: 86-24-2334-2829

Fax: 86-24-2334-2393

China - Shenzhen

Tel: 86-755-8864-2200

Fax: 86-755-8203-1760

China - Wuhan

Tel: 86-27-5980-5300

Fax: 86-27-5980-5118

China - Xian

Tel: 86-29-8833-7252

Fax: 86-29-8833-7256

ASIA/PACIFIC

China - Xiamen

Tel: 86-592-2388138

Fax: 86-592-2388130

China - Zhuhai

Tel: 86-756-3210040

Fax: 86-756-3210049

India - Bangalore

Tel: 91-80-3090-4444

Fax: 91-80-3090-4123

India - New Delhi

Tel: 91-11-4160-8631

Fax: 91-11-4160-8632

India - Pune

Tel: 91-20-3019-1500

Japan - Osaka

Tel: 81-6-6152-7160

Fax: 81-6-6152-9310

Japan - Tokyo

Tel: 81-3-6880-3770

Fax: 81-3-6880-3771

Korea - Daegu

Tel: 82-53-744-4301

Fax: 82-53-744-4302

Korea - Seoul

Tel: 82-2-554-7200

Fax: 82-2-558-5932 or

82-2-558-5934

Malaysia - Kuala Lumpur

Tel: 60-3-6201-9857

Fax: 60-3-6201-9859

Malaysia - Penang

Tel: 60-4-227-8870

Fax: 60-4-227-4068

Philippines - Manila

Tel: 63-2-634-9065

Fax: 63-2-634-9069

Singapore

Tel: 65-6334-8870

Fax: 65-6334-8850

Taiwan - Hsin Chu

Tel: 886-3-5778-366

Fax: 886-3-5770-955

Taiwan - Kaohsiung

Tel: 886-7-213-7830

Taiwan - Taipei

Tel: 886-2-2508-8600

Fax: 886-2-2508-0102

Thailand - Bangkok

Tel: 66-2-694-1351

Fax: 66-2-694-1350

EUROPE

Austria - Wels

Tel: 43-7242-2244-39

Fax: 43-7242-2244-393

Denmark - Copenhagen

Tel: 45-4450-2828

Fax: 45-4485-2829

Finland - Espoo

Tel: 358-9-4520-820

France - Paris

Tel: 33-1-69-53-63-20

Fax: 33-1-69-30-90-79

Germany - Garching

Tel: 49-8931-9700

Germany - Haan

Tel: 49-2129-3766400

Germany - Heilbronn

Tel: 49-7131-67-3636

Germany - Karlsruhe

Tel: 49-721-625370

Germany - Munich

Tel: 49-89-627-144-0

Fax: 49-89-627-144-44

Germany - Rosenheim

Tel: 49-8031-354-560

Israel - Ra'anana

Tel: 972-9-744-7705

Italy - Milan

Tel: 39-0331-742611

Fax: 39-0331-466781

Italy - Padova

Tel: 39-049-7625286

Netherlands - Drunen

Tel: 31-416-690399

Fax: 31-416-690340

Norway - Trondheim

Tel: 47-7289-7561

Poland - Warsaw

Tel: 48-22-3325737

Romania - Bucharest

Tel: 40-21-407-87-50

Spain - Madrid

Tel: 34-91-708-08-90

Fax: 34-91-708-08-91

Sweden - Gothenberg

Tel: 46-31-704-60-40

Sweden - Stockholm

Tel: 46-8-5090-4654

UK - Wokingham

Tel: 44-118-921-5800

Fax: 44-118-921-5820

Mouser Electronics

Authorized Distributor

Click to View Pricing, Inventory, Delivery & Lifecycle Information:

[Microchip:](#)

[HCS101/P](#)

Компания «Life Electronics» занимается поставками электронных компонентов импортного и отечественного производства от производителей и со складов крупных дистрибьюторов Европы, Америки и Азии.

С конца 2013 года компания активно расширяет линейку поставок компонентов по направлению коаксиальный кабель, кварцевые генераторы и конденсаторы (керамические, пленочные, электролитические), за счёт заключения дистрибьюторских договоров

Мы предлагаем:

- Конкурентоспособные цены и скидки постоянным клиентам.
- Специальные условия для постоянных клиентов.
- Подбор аналогов.
- Поставку компонентов в любых объемах, удовлетворяющих вашим потребностям.
- Приемлемые сроки поставки, возможна ускоренная поставка.
- Доставку товара в любую точку России и стран СНГ.
- Комплексную поставку.
- Работу по проектам и поставку образцов.
- Формирование склада под заказчика.
- Сертификаты соответствия на поставляемую продукцию (по желанию клиента).
- Тестирование поставляемой продукции.
- Поставку компонентов, требующих военную и космическую приемку.
- Входной контроль качества.
- Наличие сертификата ISO.

В составе нашей компании организован Конструкторский отдел, призванный помогать разработчикам, и инженерам.

Конструкторский отдел помогает осуществить:

- Регистрацию проекта у производителя компонентов.
- Техническую поддержку проекта.
- Защиту от снятия компонента с производства.
- Оценку стоимости проекта по компонентам.
- Изготовление тестовой платы монтаж и пусконаладочные работы.



Тел: +7 (812) 336 43 04 (многоканальный)

Email: org@lifeelectronics.ru