

Ultra-low power Bluetooth® low energy microphone based on SPBTLE-1S certified module

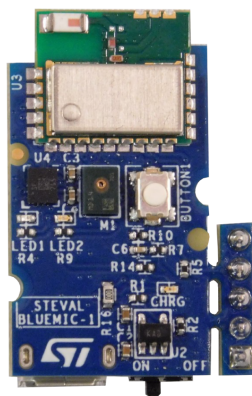

Features

- Bluetooth® SMART small form factor board based on the SPBTLE-1S module, Bluetooth v4.2 compliant
- On-board SPBTLE-1S module, based on BlueNRG-1, Bluetooth low energy application processor system on chip embedding:
 - an ultra-low power ARM® Cortex®-M0 32-bit core architecture
 - programmable embedded 160 KB Flash
 - 24 KB embedded RAM with data retention
- On-board MP34DT05-A (or MP34DT04-C1 in the first generation board) digital MEMS microphone
- On-board LSM6DSL: MEMS 3D accelerometer ($\pm 2 / \pm 4 / \pm 8 / \pm 16$ g) plus 3D gyroscope ($\pm 125 / \pm 245 / \pm 500 / \pm 1000 / \pm 2000$ dps)
- Voltage supply: 1V8 or 3V3
- Battery or USB powered
- 100 mAh Li-Ion battery
- On-board STBC08 linear Li-Ion battery charger
- SWD connector
- Included in the development kit package:
 - STEVAL-BLUEMIC-1
 - Plastic box for housing STEVAL-BLUEMIC-1
 - 100 mAh Li-Ion battery
 - SWD programming cable
- SW development kit for audio and inertial MEMS data streaming over BLE
- ST BlueMS: Android and iOS demo App available in the respective stores
- CE certified
- RoHS and China RoHS compliant
- Contains Transmitter Module FCC (ID: S9NSPBTLE1S) certified
- Contains Transmitter Module IC (IC: 8976C-SPBTLE1S) certified

Summary table	
BlueNRG-1 very low power Bluetooth low energy single mode system-on-chip embedding a high performance	BlueNRG-1
STSW-BLUEMIC-1 evaluation software package	STSW-BLUEMIC-1
STSW-BLUENRG1-DK software package	STSW-BLUENRG1-DK
MP34DT05-A ultra-compact, low-power, omnidirectional, digital MEMS microphone	MP34DT05-A
LSM6DSL 3-axis accelerometer and gyroscope	LSM6DSL
STEVAL-BLUEMIC-1 evaluation board	STEVAL-BLUEMIC-1

Description

The **STEVAL-BLUEMIC-1** evaluation board mounts the **SPBTLE-1S** Bluetooth® SMART application processor compliant with BT specification v4.2. It supports multiple simultaneous roles and can act as a Bluetooth Smart master and slave device at the same time.

This BLE wireless battery powered solution also embeds digital MEMS microphone **MP34DT05-A** (or MP34DT04-C1 in the first generation board) and 3D accelerometer + 3D gyroscope, which render this evaluation board suitable for a wide range of advanced smart applications.

The evaluation board comes with a SW development kit that includes the Bluetooth low energy stack, all the drivers for audio and inertial data acquisition, and button and LED management. A ready-to-use BlueVoice library is included as middleware and a sample application is provided to get you started with voice streaming over BLE to an Android or iOS device, running the ST BlueMS apps.

1 Schematic diagrams

Figure 1. Power and SPBTLE-1S module

Figure 2. MEMS, button and LEDs

Revision history

Table 1. Document revision history

Date	Version	Changes
18-Jul-2017	1	Initial release.
20-Nov-2017	2	Updated cover page features.
06-Feb-2018	3	Added device summary table in cover page. Update schematic diagrams.

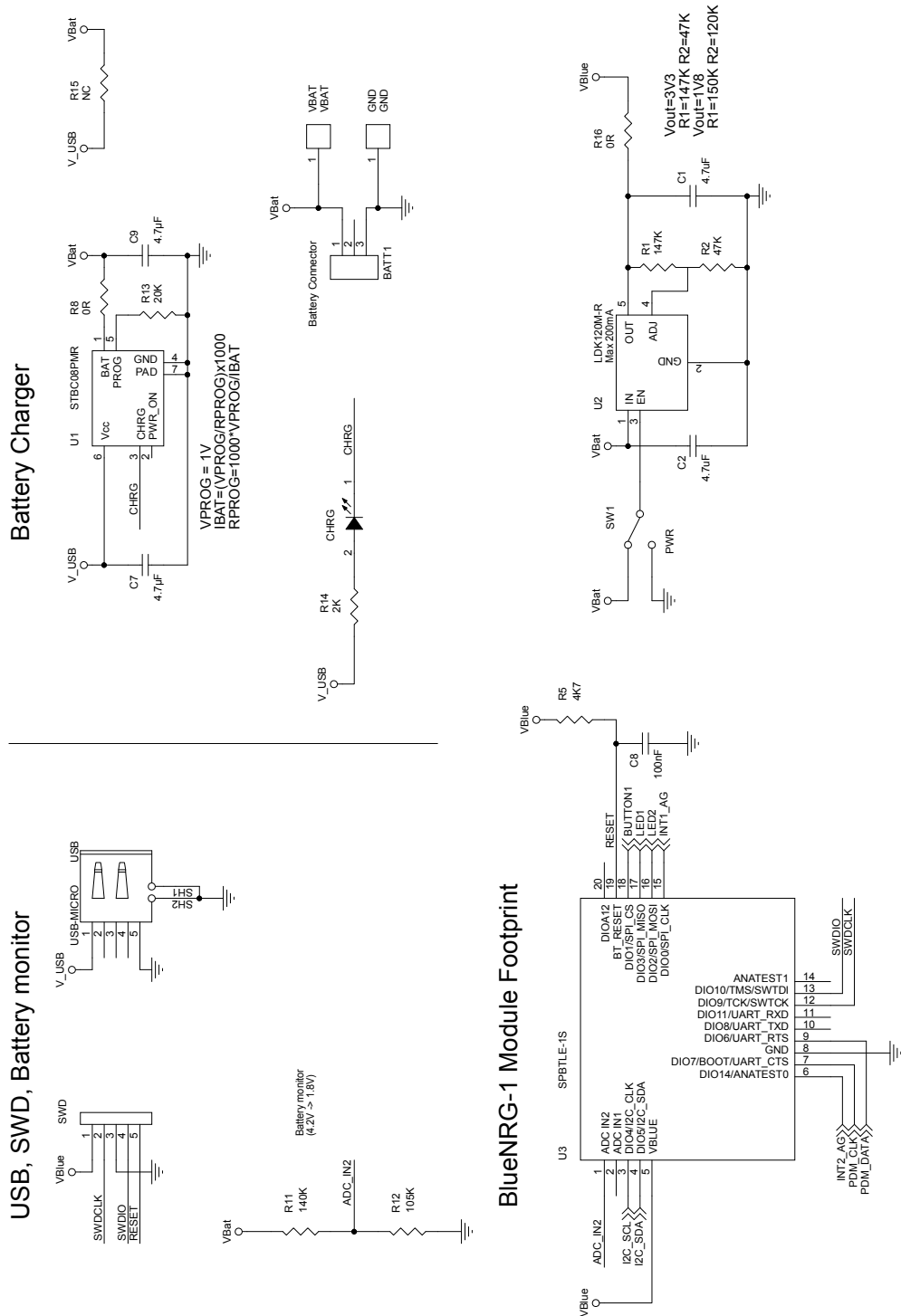
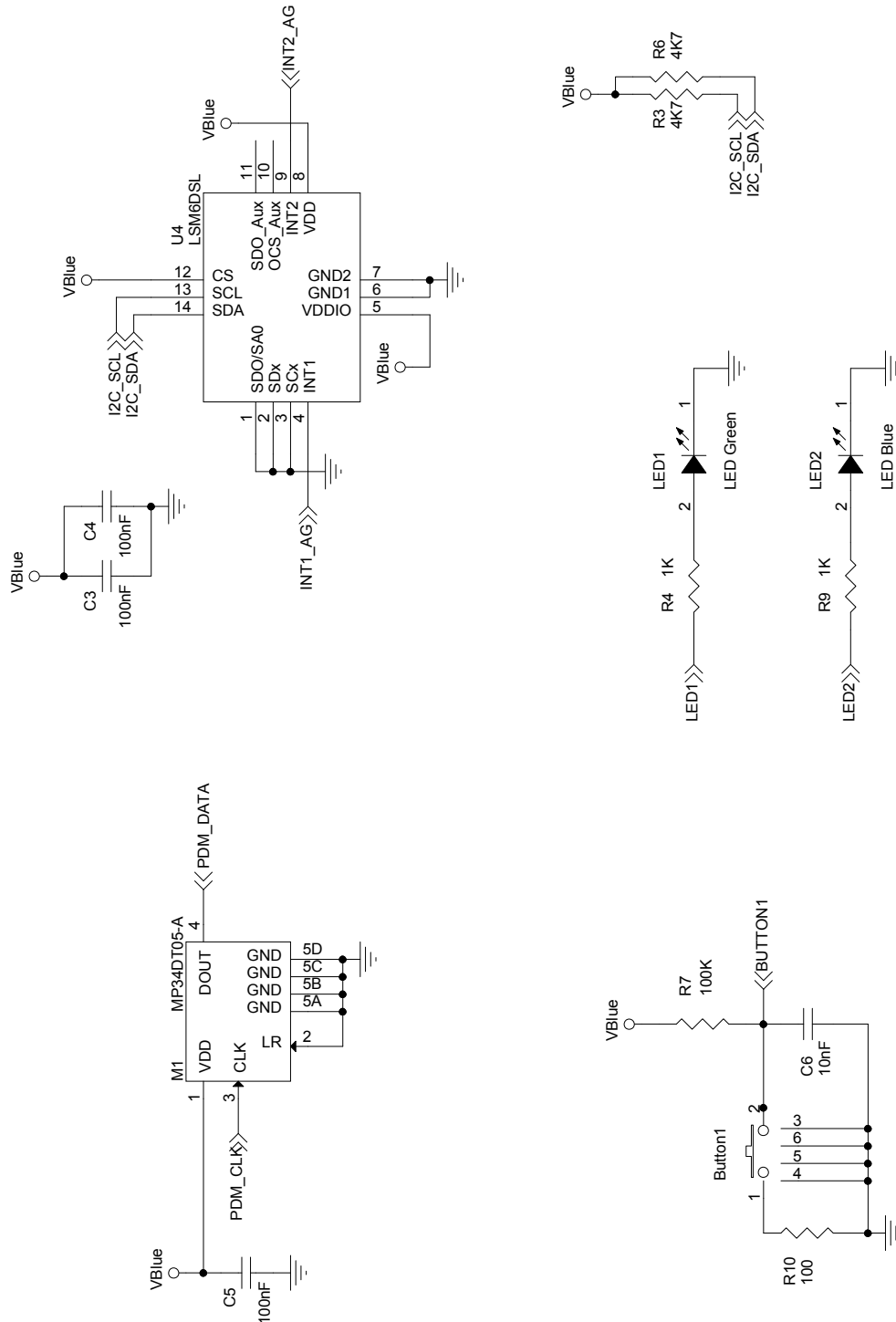
IMPORTANT NOTICE – PLEASE READ CAREFULLY

STMicroelectronics NV and its subsidiaries (“ST”) reserve the right to make changes, corrections, enhancements, modifications, and improvements to ST products and/or to this document at any time without notice. Purchasers should obtain the latest relevant information on ST products before placing orders. ST products are sold pursuant to ST’s terms and conditions of sale in place at the time of order acknowledgement.

Purchasers are solely responsible for the choice, selection, and use of ST products and ST assumes no liability for application assistance or the design of Purchasers’ products.

No license, express or implied, to any intellectual property right is granted by ST herein.

Resale of ST products with provisions different from the information set forth herein shall void any warranty granted by ST for such product.

ST and the ST logo are trademarks of ST. All other product or service names are the property of their respective owners.

Information in this document supersedes and replaces information previously supplied in any prior versions of this document.

© 2018 STMicroelectronics – All rights reserved

Компания «Life Electronics» занимается поставками электронных компонентов импортного и отечественного производства от производителей и со складов крупных дистрибьюторов Европы, Америки и Азии.

С конца 2013 года компания активно расширяет линейку поставок компонентов по направлению коаксиальный кабель, кварцевые генераторы и конденсаторы (керамические, пленочные, электролитические), за счёт заключения дистрибьюторских договоров

Мы предлагаем:

- Конкуренспособные цены и скидки постоянным клиентам.
- Специальные условия для постоянных клиентов.
- Подбор аналогов.
- Поставку компонентов в любых объемах, удовлетворяющих вашим потребностям.
- Приемлемые сроки поставки, возможна ускоренная поставка.
- Доставку товара в любую точку России и стран СНГ.
- Комплексную поставку.
- Работу по проектам и поставку образцов.
- Формирование склада под заказчика.
- Сертификаты соответствия на поставляемую продукцию (по желанию клиента).
- Тестирование поставляемой продукции.
- Поставку компонентов, требующих военную и космическую приемку.
- Входной контроль качества.
- Наличие сертификата ISO.

В составе нашей компании организован Конструкторский отдел, призванный помогать разработчикам, и инженерам.

Конструкторский отдел помогает осуществить:

- Регистрацию проекта у производителя компонентов.
- Техническую поддержку проекта.
- Защиту от снятия компонента с производства.
- Оценку стоимости проекта по компонентам.
- Изготовление тестовой платы монтаж и пусконаладочные работы.



Тел: +7 (812) 336 43 04 (многоканальный)

Email: org@lifeelectronics.ru