

KGZ-10 Series Oxygen Sensors



DESCRIPTION

The KGZ-10 is a high-accuracy, zirconia-based oxygen sensor. The ability of the sensor to operate without any reference gas makes it ideal for potential applications such as combustion control or aircraft oxygen generation systems.

The sensor employs two ZrO_2 discs with a small hermetically sealed chamber in between. One of the discs functions as a reversible oxygen pump, which is used to successively fill and empty the chamber. The second disc measures the ratio of the partial pressure difference and generates a corresponding sense voltage.

FEATURES

- High-accuracy measurement
- Low power consumption
- No reference gas required
- Linear output signal
- No need for temperature stabilization
- Function testing and calibration in ambient air
- Long life

A heat element produces the $700\text{ }^{\circ}\text{C}$ [$1292\text{ }^{\circ}\text{F}$] required for the ZrO_2 to operate as an O_2 pump. The time taken for the pump to achieve specific minimum and maximum pressures within this chamber is a measure of the partial oxygen pressure of the environment.

The KGZ-10 has to be operated by an electronic measuring circuit that controls the sensor operation and signal processing. This circuit can either be incorporated into the customer's own electronics, or be purchased as a separate interface board from Honeywell.

POTENTIAL APPLICATIONS

- Boiler combustion controls
- Aircraft oxygen generation systems

KGZ-10 Series

Table 1. Technical Specifications

Characteristic	Parameter
Sensor voltage levels (recommended)	45-64-85 mV
Pump current (recommended)	40 uA
Heater supply,	4.0 V (1.7 A)
Heater supply (stand by)	2.0 V
Pump resistance at 700 °C [1292 °F]:	
dc	1 kOhm, typ.
ac	1 kHz, 120 Ohm, typ.
Oxygen pressure range	2 mbar to 3 bar
Operational temperature	700 °C [1292 °F]
Stand by temperature	500 °C [932 °F], typ.
Sensitivity	1.05 ms/mbar
Accuracy	<5 mbar
Response time	<4 s
Warm up time	<100 s
Warm up time (from stand by)	<20 s
Permissible gas temperature	-100 °C/250 °C [-148 °F/482 °F]
Gas flow rate	0 m/s to 10 m/s
Repetitive permissible acceleration	5 g
Incidental permissible acceleration	30 g

Oxygen Sensors

Figure 1. KGZ-10 Dimensions (For reference only: mm/in.)



Figure 2. KGZ-10SP Dimensions (For reference only: mm/in.)

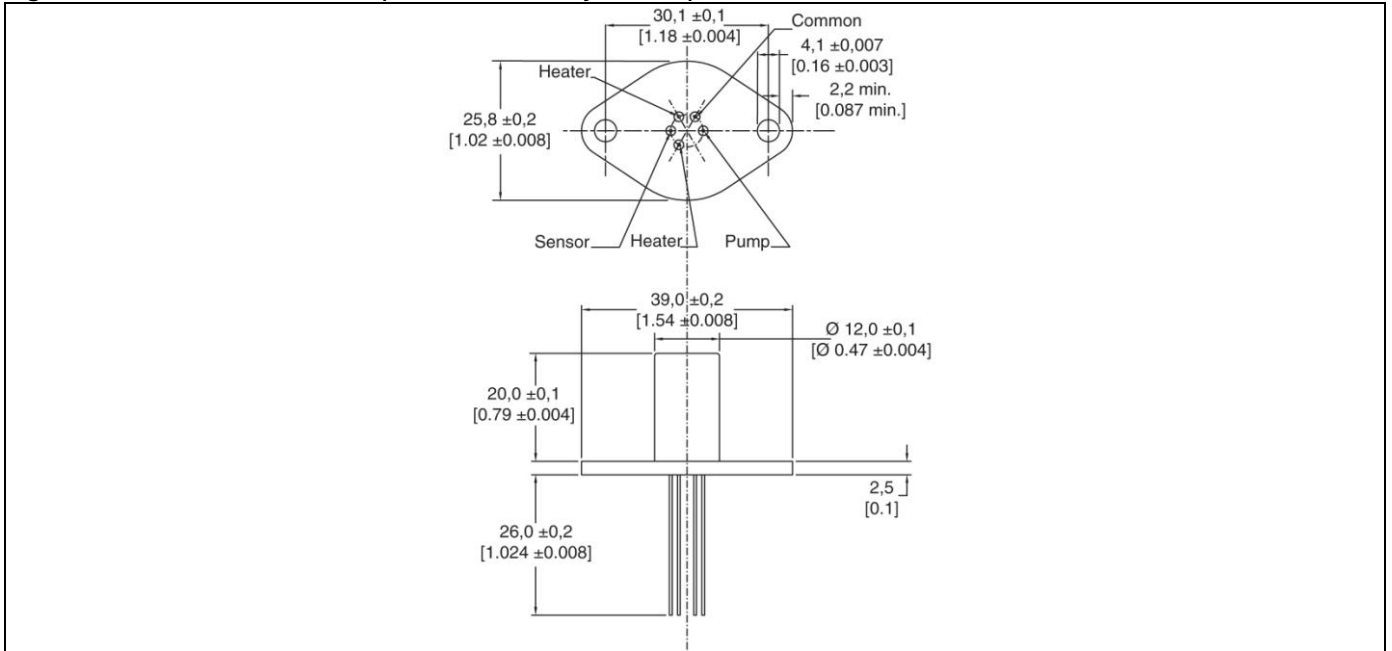

Order Guide

Catalog Listing	Description
KGZ-10	Oxygen sensor, flange mount with tabs
KGZ-10SP	Oxygen sensor, flange mount with pins

WARNING

PERSONAL INJURY

DO NOT USE these products as safety or emergency stop devices or in any other application where failure of the product could result in personal injury.

Failure to comply with these instructions could result in death or serious injury.

WARRANTY/REMEDY

Honeywell warrants goods of its manufacture as being free of defective materials and faulty workmanship. Honeywell's standard product warranty applies unless agreed to otherwise by Honeywell in writing; please refer to your order acknowledgement or consult your local sales office for specific warranty details. If warranted goods are returned to Honeywell during the period of coverage, Honeywell will repair or replace, at its option, without charge those items it finds defective. **The foregoing is buyer's sole remedy and is in lieu of all other warranties, expressed or implied, including those of merchantability and fitness for a particular purpose. In no event shall Honeywell be liable for consequential, special, or indirect damages.**

While we provide application assistance personally, through our literature and the Honeywell web site, it is up to the customer to determine the suitability of the product in the application.

Specifications may change without notice. The information we supply is believed to be accurate and reliable as of this printing. However, we assume no responsibility for its use.

WARNING

MISUSE OF DOCUMENTATION

- The information presented in this product sheet is for reference only. Do not use this document as a product installation guide.
- Complete installation, operation, and maintenance information is provided in the instructions supplied with each product.

Failure to comply with these instructions could result in death or serious injury.

SALES AND SERVICE

Honeywell serves its customers through a worldwide network of sales offices, representatives and distributors. For application assistance, current specifications, pricing or name of the nearest Authorized Distributor, contact your local sales office or:

E-mail: info.sc@honeywell.com

Internet: www.honeywell.com/sensing

Phone and Fax:

Asia Pacific	+65 6355-2828
	+65 6445-3033 Fax
Europe	+44 (0) 1698 481481
	+44 (0) 1698 481676 Fax
Latin America	+1-305-805-8188
	+1-305-883-8257 Fax
USA/Canada	+1-800-537-6945
	+1-815-235-6847
	+1-815-235-6545 Fax

Sensing and Control
Honeywell
1985 Douglas Drive North
Golden Valley, MN 55422
www.honeywell.com/sensing

100458-3-EN IL50 GLO Printed in USA
February 2011
Copyright © 2011 Honeywell International Inc. All rights reserved.

Honeywell

Компания «Life Electronics» занимается поставками электронных компонентов импортного и отечественного производства от производителей и со складов крупных дистрибьюторов Европы, Америки и Азии.

С конца 2013 года компания активно расширяет линейку поставок компонентов по направлению коаксиальный кабель, кварцевые генераторы и конденсаторы (керамические, пленочные, электролитические), за счёт заключения дистрибьюторских договоров

Мы предлагаем:

- Конкурентоспособные цены и скидки постоянным клиентам.
- Специальные условия для постоянных клиентов.
- Подбор аналогов.
- Поставку компонентов в любых объемах, удовлетворяющих вашим потребностям.
- Приемлемые сроки поставки, возможна ускоренная поставка.
- Доставку товара в любую точку России и стран СНГ.
- Комплексную поставку.
- Работу по проектам и поставку образцов.
- Формирование склада под заказчика.
- Сертификаты соответствия на поставляемую продукцию (по желанию клиента).
- Тестирование поставляемой продукции.
- Поставку компонентов, требующих военную и космическую приемку.
- Входной контроль качества.
- Наличие сертификата ISO.

В составе нашей компании организован Конструкторский отдел, призванный помогать разработчикам, и инженерам.

Конструкторский отдел помогает осуществить:

- Регистрацию проекта у производителя компонентов.
- Техническую поддержку проекта.
- Защиту от снятия компонента с производства.
- Оценку стоимости проекта по компонентам.
- Изготовление тестовой платы монтаж и пусконаладочные работы.



Тел: +7 (812) 336 43 04 (многоканальный)

Email: org@lifeelectronics.ru