



# USBF TV (USB-A)

USB Connection System for Harsh Environment



With USB Field, you can insert a standard USB 2.0 cordset into a metallic plug which will protect it from shocks, dust and fluids.

**No hazardous on-field cabling and grounding!**

This metallic plug is connected into a receptacle, using a Tri Start Thread coupling mechanism (MIL-DTL-38999 series III type) with anti-decoupling device for high vibrations.

**Applications**

- Embedded Computers
- Data Acquisition and transmission in harsh environment
- Railways
- Battelfield Communication Systems
- Navy Systems

**Data Transmission**

USB Specification 2.0  
Data Rate: Up to 480 Mb/s for High Speed USB

**MAIN CHARACTERISTICS**

- Sealed against fluids and dusts (IP68)
- Shock, Vibration and Traction resistant
- No cabling operation in field and no tools required
- Improved EMI protection
- Tri Start Thread coupling mechanism (MIL-DTL-38999 series III type) with anti-decoupling device
- 2 mechanical Coding / Polarization possibilities by the user (receptacle insert rotation)
- USBF TV plug retention in the receptacle: 100 N in the axis
- Mating cycles: 500 to 1500

**Environmental Protection**

- Sealing (when mated): IP68 (Temporary immersion)
- Salt Spray: 48 h with Nickel plating  
> 500 h with Olive Drab Cadmium  
1000 h with marine bronze shell
- Fire Retardant / Low Smoke: UL94 V0 and NF F 16 101 & 16 102
- Vibrations: 10 – 500 Hz, 10 g, 3 axes: no discontinuity > 1micro s
- Shocks: IK06: weight of 250 g drop from 40 cm [15.75 in] onto connectors (mated pair)
- Humidity: 21 days, 43°C, 98% humidity
- Temperature Range: - 40°C / +85°C

**Part Number Code**

<b>Series</b> USB Field TV	<b>USBF TV</b>	<b>2</b>	<b>1</b>	<b>G</b>
<b>Shell Type</b>				
<b>6:</b>	Plug			
<b>2:</b>	Square flange receptacle			
<b>2PE:</b>	Square flange receptacle with metal backshell (type 1) & with metal backshell + plastic gland (type 2)			
<b>2PEM:</b>	Square flange receptacle with backshell + metal gland (only for back termination type 2 = Solder)			
<b>7:</b>	Jam nut receptacle			
<b>7PE:</b>	Jam nut receptacle with metal backshell (type 1) & with metal backshell + plastic gland (type 2)			
<b>7PEM:</b>	Jam nut receptacle with backshell + metal gland (only for back termination type 2 = Solder)			
<b>Back Terminations (Receptacles only)</b>				
<b>1:</b>	Female USB-A			
<b>2:</b>	Solder (4 tinned holes)			
<b>Shells Material &amp; Finish</b>				
<b>N:</b>	Aluminium shell - Nickel plating - ROHS compliant			
<b>G:</b>	Aluminium shell - Olive Drab Cadmium plating			
<b>BZ:</b>	Marine bronze shell - ROHS compliant			

- Examples:
- Olive Drab Cadmium Plug: USBF TV 6G
  - Olive Drab Cadmium Square Flange Receptacle, USB-A back terminat°: USBF TV 21G
  - Olive Drab Cadmium Jam Nut Receptacle, USB-A receptacle back terminat°: USBF TV 71G
  - Nickel Jam Nut Receptacle, solder termination: USBF TV 72N

**Plug**

- Shell type 6

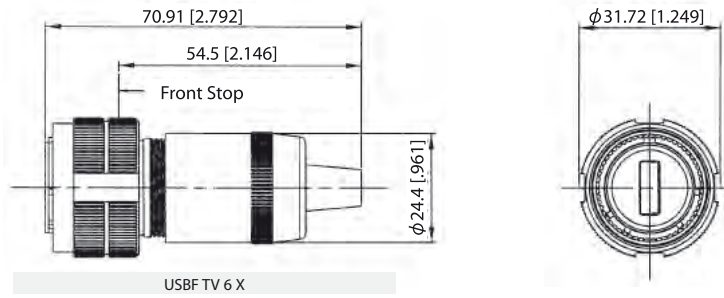

**Receptacles**

- Square flange receptacle  
4 mounting holes: Shell type 2

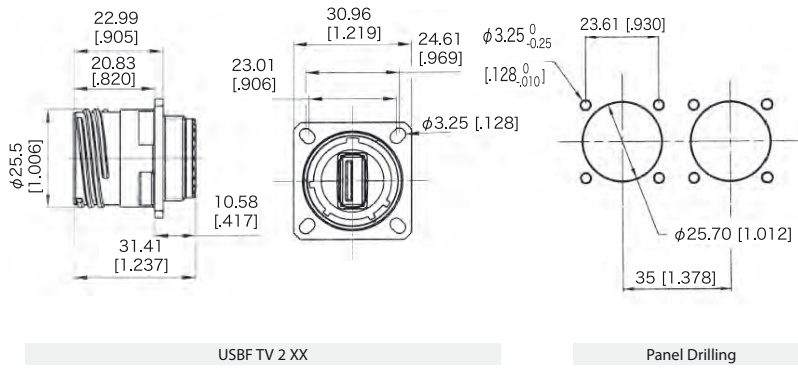

- Jam nut receptacle  
Hexagonal Nut mounting:  
Shell type 7

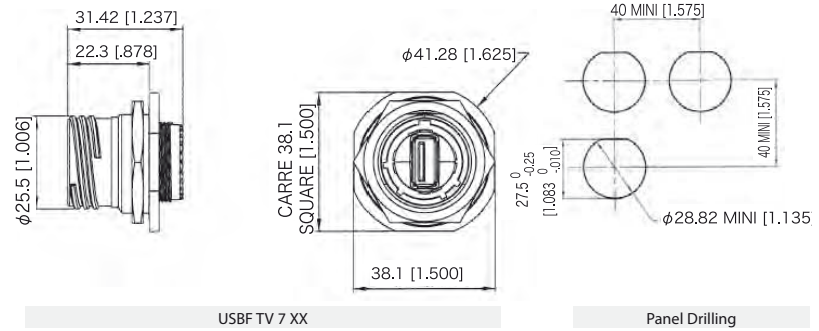

- Receptacles with backshell  
Shell type 2PE and 7PE

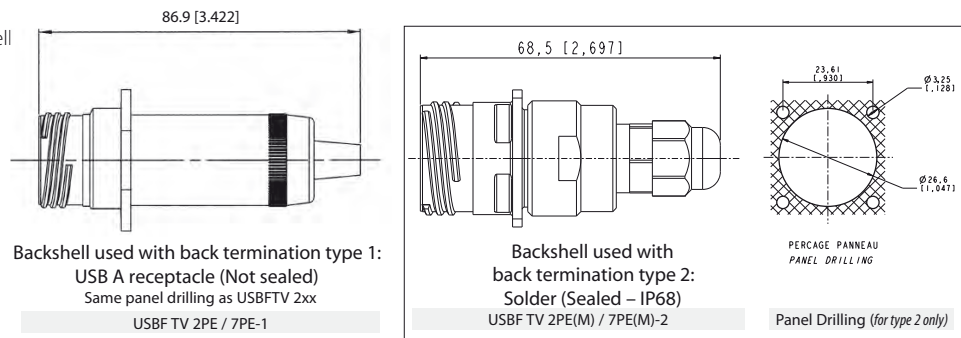

**Back Terminations**



Type 1: Female USB-A



Type 2: Solder 4 Tinned holes to solder your cable

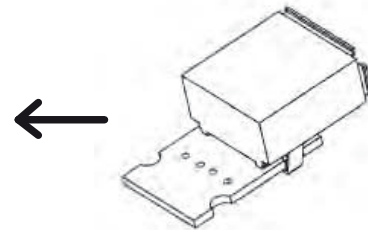

View of the PCB of the Type 2 version with 4 tinned holes for solder termination

## Assembly Instructions

Can be used with most the USB cordset brands: No tools required!

### Plug Assembly

1. Only if you need a full sealing (IP68): Install the white sticker around the plug, covering the 4 little holes of the overmolding
2. Insert the black O Ring around the front face of the USB A plug. This O Ring will ensure connection sealing
3. Insert the USB cordset into the metallic backshell
4. Insert the retention spacer laterally to the cable (this spacer is soft, in order to adapt to different shapes of overmolding) and slide the overmolding of the USB-A plug into this retention spacer
5. Insert the friction ring laterally to the cable
6. Choose the right coding (2 positions) and insert the USB-A plug into the protective plug. Note at this step, the main key is used for polarization.



7. Screw the backshell on the plug body. A wrench can be necessary to fully tighten it, and the connection to the receptacle can help

### IMPORTANT NOTE

The connection sealing is not done by the black retention spacer (which is slotted), but by the front face ORing (fig. 2)

### Receptacle Assembly

Insert the USB module from the rear. Reference is main key. Beware to have a coding compatible with the coding you used for the plug: on front view, the white shapes in the USBs must be on the same side.

To remove the USB module, insert the removal tool **USBF ODE** from the front, and push back the module.

### Accessories

#### ■ Metallic Caps

	USBF TVC	2	G
<b>Connector Type</b>			
6:	Plug		
2:	Square Flange Receptacle		
7:	Jam Nut Receptacle		
<b>Shells Material &amp; Finish</b>			
N:	Aluminium shell - Nickel - ROHS compliant		
G:	Aluminium shell - Olive Drab Cadmium		
BZ:	Marine bronze shell - ROHS compliant		

- Panel Gasket for square flange receptacle (Thickness: 0,8 mm [.031]): JE15



- Receptacle Insert removal tool: USBF ODE

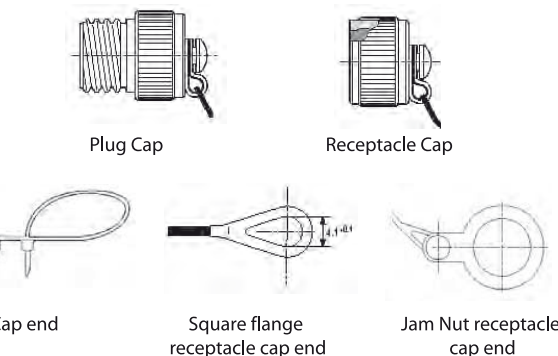

Компания «Life Electronics» занимается поставками электронных компонентов импортного и отечественного производства от производителей и со складов крупных дистрибьюторов Европы, Америки и Азии.

С конца 2013 года компания активно расширяет линейку поставок компонентов по направлению коаксиальный кабель, кварцевые генераторы и конденсаторы (керамические, пленочные, электролитические), за счёт заключения дистрибьюторских договоров

Мы предлагаем:

- Конкурентоспособные цены и скидки постоянным клиентам.
- Специальные условия для постоянных клиентов.
- Подбор аналогов.
- Поставку компонентов в любых объемах, удовлетворяющих вашим потребностям.
- Приемлемые сроки поставки, возможна ускоренная поставка.
- Доставку товара в любую точку России и стран СНГ.
- Комплексную поставку.
- Работу по проектам и поставку образцов.
- Формирование склада под заказчика.
- Сертификаты соответствия на поставляемую продукцию (по желанию клиента).
- Тестирование поставляемой продукции.
- Поставку компонентов, требующих военную и космическую приемку.
- Входной контроль качества.
- Наличие сертификата ISO.

В составе нашей компании организован Конструкторский отдел, призванный помогать разработчикам, и инженерам.

Конструкторский отдел помогает осуществить:

- Регистрацию проекта у производителя компонентов.
- Техническую поддержку проекта.
- Защиту от снятия компонента с производства.
- Оценку стоимости проекта по компонентам.
- Изготовление тестовой платы монтаж и пусконаладочные работы.



Тел: +7 (812) 336 43 04 (многоканальный)

Email: [org@lifeelectronics.ru](mailto:org@lifeelectronics.ru)