

Altech Corp.®

Serving the Automation & Control Industry since 1984



ISO 9001
QMI-SAI Global



Altech Smart Relay & Digital Multi-Timer

Altech® Smart Relay



Standards and Certifications

- UL 508
- IEC 61000-3-2
- IEC 61000-4-2-1~11

Features

- Supports upto 48 I/Os (32 digital inputs & 16 digital outputs)
- DST Feature Available
- Backlit LCD Screen for display & modification of pre-selected parameters of functional blocks, viewing I/O status and programming on the device
- PC software for programming, online & offline simulation, documentation & printing
- Designed for use in automation for commercial & Industrial sectors
- Modbus Communication

Programming Features

- 250 lines of ladder programming
- 16 soft text messages, Time Switches, Compare Counters, Timers, Counters & 12 analog functions

Function Blocks

Timers:	16 (ON Delay, Interval, Cyclic ON-OFF, OFF Delay)
Counters:	16 (Up/Down, Retentive selectable)
Time Switches:	16 (Weekly / Daily)
Compare Counters:	16
Analog Functions:	12 (DC Model)
Soft Text Messages:	16 (Priority Driven)
Auxiliary Relays:	32

FREE SOFTWARE DOWNLOAD

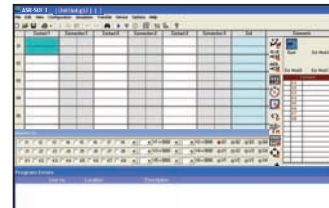

AltechCorp.com/SmartRelay



Mounting Dimensions

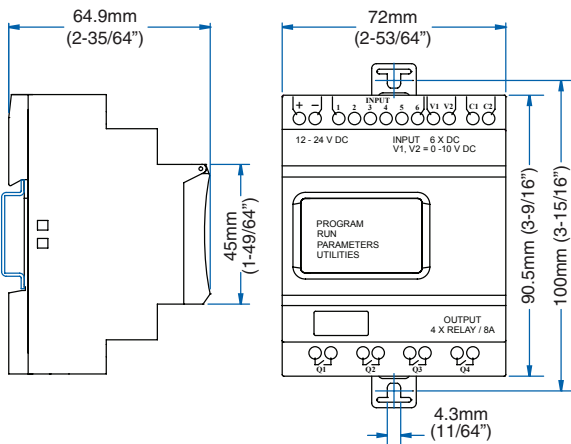

**Programmable Smart Relay
Base Module**

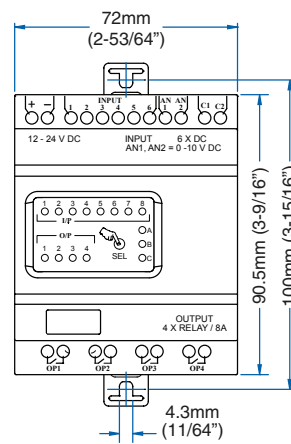

**Programmable Smart Relay
Expansion Module**

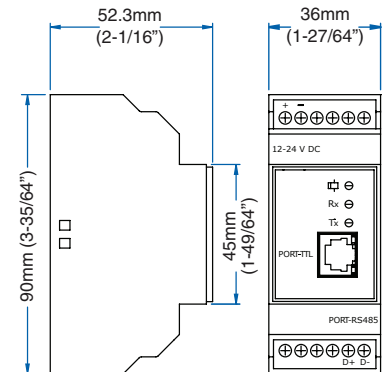

**Programmable Smart Relay
Communication Module**

Altech Smart Relay

Technical Specifications

I/O Extensions (Max.)	3	
Utilization Category	AC-15	Rated Voltage (Ue): 120/240 V, Rated Current (Ie): 3.0/1.5 A
	DC-13	Rated Voltage (Ue): 24/125/250 V, Current (Ie): 2.0/0.22/0.1 A
Power Reserve (For Clock Only)	150h at -10°C to +55°C	
Operating Temperature	-10°C to +55°C	
Storage Temperature	-25°C to +70°C	
Humidity (Non Condensing)	95% (Rh)	
Enclosure	Flame Retardant UL 94-V0	
Mounting	Base / DIN Rail	
Degree of Protection	IP 20 for Terminals, IP 40 for Enclosure	



Base Module



Expansion Module

Base Module

Cat. No.	ASR-B120AC	ASR-B24DC
Supply Voltage (-20% to + 10%)	110-240 VAC (50/60Hz)	12-24 VDC
Power Consumption	5W	5W
Max. Supply current	36 mA	360 mA
Digital Inputs	8	6
Digital Input Range	(0-40VAC) OFF,(80-265VAC) ON	(0-4VDC) OFF,(8-26.4VDC) ON
Analog Inputs	N/A	2 (can be used as Digital Inputs)
Analog Input Range	N/A	0 to 10 VDC
Digital Relay Output	4 NO (8A@240V AC, 5A@30V DC)	4 NO (8A@240V AC, 5A@30V DC)
Weight	0.51 lb. (230 g)	0.51 lb. (230 g)

Expansion Module

Cat. No.	ASR-E120AC	ASR-E24DC
Digital Inputs	8	6
Digital Input Range	(0-40VAC) OFF,(80-265VAC) ON	(0-4VDC) OFF,(8-26.4VDC) ON
Analog Inputs	N/A	2 (can be used as Digital Inputs)
Analog Input Range	N/A	0 to 10 VDC
Digital Relay Output	4 NO (8A@240V AC, 5A@30V DC)	4 NO (8A@240V AC, 5A@30V DC)
Weight	0.5 lb. (225 g)	0.5 lb. (225 g)

RS485 Communication Module (including communication cable)

Input	TTL Level
Output	RS-485 protocol (two wires, D+, D-)
Number of Nodes	32 standard unit loads
Isolation Voltage	2000 Vrms
Baud Rate	300, 600, 1200, 2400, 4800, 9600
Operating temperature	-10°C to +55°C
Storage temperature	-20°C to +70°C
LED Indicators	Red LED's for Tx & Rx. Green LED for Power indication
Weight	0.19 lb. (84 g)



Communication Cable

Cat. No.	ASR-C485-120AC	ASR-C485-24DC
Supply Voltage	110-240 VAC	12-24 VDC
Weight	0.18 lb. (80 g)	0.19 lb. (84 g)

Accessories



Cat. No.	ASR-MC	ASR-USB	ASR-RS232
Weight	Memory Card 0.18 lb. (80 g)	USB Cable 0.22 lb. (100 g)	Serial RS232 Cable 0.24 lb. (110 g)

Connection Diagrams

SUPPLY, INPUT & OUTPUT CONNECTIONS

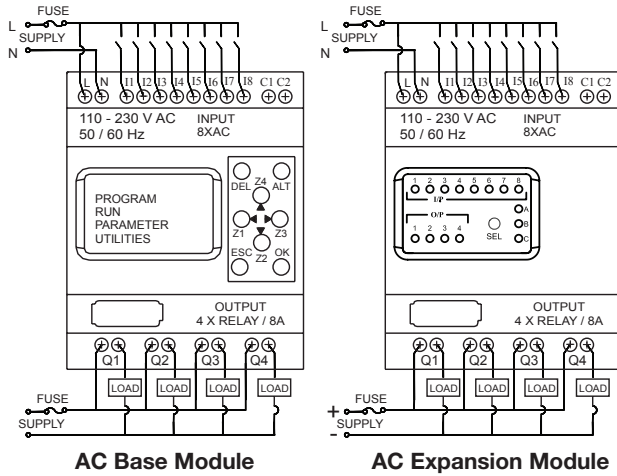

Fig. 1

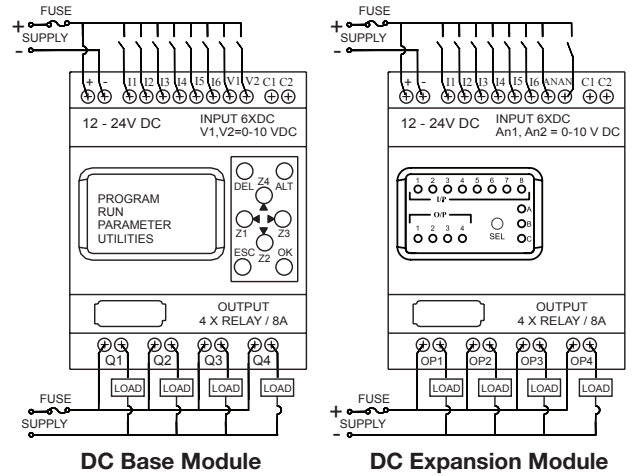

Fig. 2

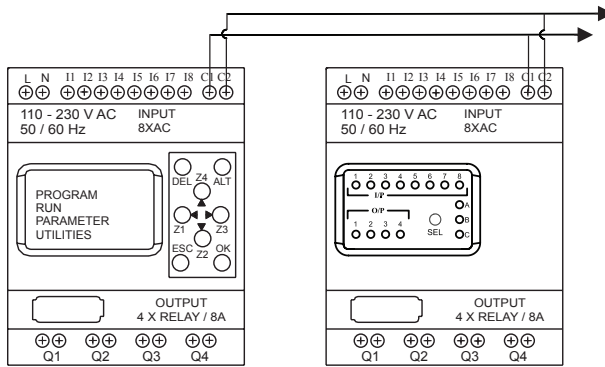

Fig. 3

Connection Between Base Module & Expansion

Same for both AC & DC



Fig. 4

Connection Between Base Module & Communication Module

Power Supply Wiring

1. Although the Altech Smart Relay has been designed to withstand the negative effects of any electrical noise that might be present its power supply. It may be necessary to insert an isolation transformer between the supply and line terminals of the Altech Smart Relay.
2. While using the DC Altech Smart Relay, run the 24 VDC Input line separate from 100 ~240V AC power lines.

Wiring of Input/Output

1. Separate input and output lines.
2. When the output lines are running close to power supply or input lines, use shielded wires and ground them.

Altech Universal Digital Multi-Timer

Altech's AMT-Series of Universal Digital Multi-Timers comprises 4 models featuring 8 or 18 timer functions to offer highest flexibility in controlling operations. The time range is adjustable from 0.1s to 999h. An LCD display shows current Run time information.

Features

- Multifunctional Timer (8 or 18 Functions)
- Universal Voltage 24~265 VAC/ DC
- Wide Time Range: 0.1s ~ 999h
- 3 Digit LCD Display for Preset Time and Run Time
- DIN Rail Mounted
- 17.5mm Width



Digital Timers

Cat. No.	AMT8-S1	AMT8-D2	AMT12-S1	AMT12-D2
Output Contacts	1 C/O	2 NO	1 C/O	2 NO
No. of Timer Functions	8	8	18	18
Functions / [setting mode]	1) ON Delay [A]		1) ON Delay [Q]	
	2) Cyclic OFF/ ON [b]		2) Cyclic OFF/ ON [1]	
	3) Cyclic ON/ OFF [c]		3) Cyclic ON/ OFF [2]	
	4) Signal ON/ OFF [d]		4) Impulse on Energizing [3]	
	5) Signal OFF Delay [E]		5) Accumulative Delay on Signal [4]	
	6) Interval [F]		6) Accumulative Delay on Inverted Signal [5]	
	7) Signal OFF/ ON [G]		7) Accumulative Impulse on Signal [6]	
	8) One Shot Output [H]		8) Signal ON Delay [7]	
			9) Inverted Signal ON Delay [8]	
			10) Signal OFF Delay [9]	
			11) Impulse ON/ OFF [R]	
			12) Signal OFF/ ON [b]	
			13) Leading Edge Impulse 1 [C]	
			14) Leading Edge Impulse 2 [d]	
			15) Trailing Edge Impulse 1 [E]	
			16) Trailing Edge Impulse 2 [F]	
			17) Delayed Impulse [G]	
			18) Inverted Signal ON Delay 2 [H]	

Specifications

Supply Voltage	24 - 265 VAC/ DC (50, 60Hz)
Power Consumption	10 VA max.
Timing Range	0.1s ~ 999h
Reset Time	200ms max.
Repeat Accuracy	+/-0.5%
Output Contact Rating	8A @ 240 VAC/ 24 VDC (resistive)
Electrical Life	10,000 switching cycles
Mechanical Life	2,000,000 switching cycles
AC-15 Rating	Rated Voltage (Ue): 125/ 240V, Rated Current (Ie): 3/1.5A
DC-13 Rating	Rated Voltage (Ue): 125/ 250V, Rated Current (Ie): 2/0.22/0.1A
Operating Temperature	-10°C ~ +55°C (+14°F ~ 131°F)
Storage Temperature	-20°C ~ +65°C (-4°F ~ 149°F)
Weight	85g (0.14lb.)
Protection Enclosure	IP30
Protection Terminals	IP20
Torque	0.40 Nm (3.5 lb.in.)
Terminal Wire Size	0.3-2.5 mm ² (22-14 AWG)

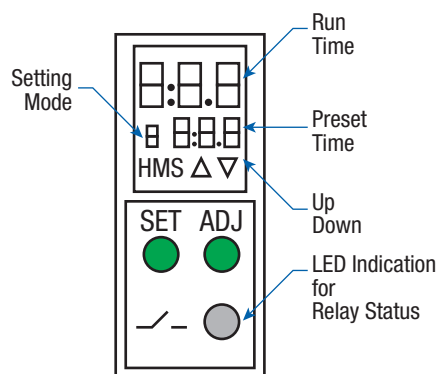

Connection Diagrams

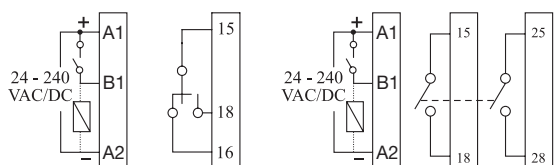

AMT8-S1, AMT12-S1

AMT8-S2, AMT12-S2

Dimensions

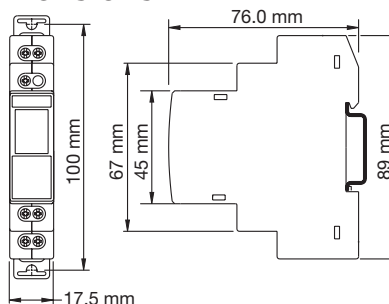

Scan this QR code for more information.



Компания «Life Electronics» занимается поставками электронных компонентов импортного и отечественного производства от производителей и со складов крупных дистрибьюторов Европы, Америки и Азии.

С конца 2013 года компания активно расширяет линейку поставок компонентов по направлению коаксиальный кабель, кварцевые генераторы и конденсаторы (керамические, пленочные, электролитические), за счёт заключения дистрибьюторских договоров

Мы предлагаем:

- Конкурентоспособные цены и скидки постоянным клиентам.
- Специальные условия для постоянных клиентов.
- Подбор аналогов.
- Поставку компонентов в любых объемах, удовлетворяющих вашим потребностям.
- Приемлемые сроки поставки, возможна ускоренная поставка.
- Доставку товара в любую точку России и стран СНГ.
- Комплексную поставку.
- Работу по проектам и поставку образцов.
- Формирование склада под заказчика.
- Сертификаты соответствия на поставляемую продукцию (по желанию клиента).
- Тестирование поставляемой продукции.
- Поставку компонентов, требующих военную и космическую приемку.
- Входной контроль качества.
- Наличие сертификата ISO.

В составе нашей компании организован Конструкторский отдел, призванный помогать разработчикам, и инженерам.

Конструкторский отдел помогает осуществить:

- Регистрацию проекта у производителя компонентов.
- Техническую поддержку проекта.
- Защиту от снятия компонента с производства.
- Оценку стоимости проекта по компонентам.
- Изготовление тестовой платы монтаж и пусконаладочные работы.



Тел: +7 (812) 336 43 04 (многоканальный)
Email: org@lifeelectronics.ru