

STRADA WHISPER

Backplane Connector



INTRODUCING

STRADA Whisper Backplane Connector

Blinding Speeds

The STRADA Whisper backplane family was designed with your end customer's need for high-performing, high-bandwidth systems in mind. Its revolutionary design transfers data at blinding speeds of 25 Gbps and offers unparalleled scalability up to 40 Gbps—allowing you to achieve efficient future system upgrades without costly backplane or midplane redesigns.

Performance Matters

The STRADA Whisper product family operates with extremely low noise, low insertion loss and little to no skew—all of which provide system architects with design flexibility and high design margin. Specific versions are available for 100-Ohm and 85-Ohm applications so you don't have to compromise on impedance discontinuities.

Mechanically, the STRADA Whisper connector family mirrors most high-speed backplane connectors in the market for easy implementation. It differentiates itself through folded signal pins surrounded by strong, protective C-shaped shields, which make the product family one of the most robust offerings in the market. Additionally, the connector footprint keeps crosstalk down and the overall connector design uses latest eye-of-needle (EON) technology.

Your Design Partner For 25-Gbps Architectures

To ensure smooth transitions from 10-Gbps to 25-Gbps systems using the STRADA Whisper connector, TE can assign a team of experts—comprised of our best signal integrity and mechanical engineers—to help you develop a solution that fits right into your architecture. Whether it's traditional backplane, orthogonal midplane, or a cabled-backplane system, TE can tailor the STRADA Whisper product portfolio to best fit and enable your system architecture.

Applications

- Servers & Storage
- Switches
- Routers
- Optical Transport
- Wireless infrastructure

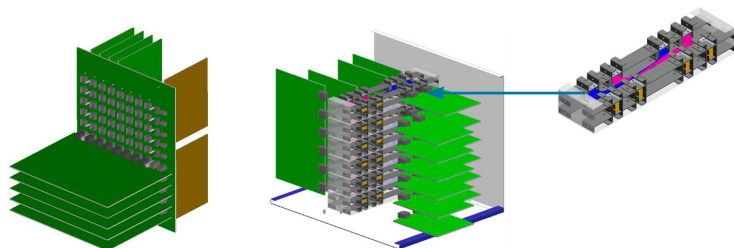

Orthogonal Midplane

Cabled-Midplane

Electrical Specifications

- Power Sum FEXT is lower than -50 dB for system implementation at 12.5 GHz
- Insertion loss is less than 1dB and linear up to 20 GHz
- Individual shielded pairs offer excellent signal integrity / EMI performance
- Little to no skew through high-speed differential pairs
- Common mode impedance controlled throughout the connector, including footprint and mating interface
- Superior 25-Gbps electrical performance maintained even in a 1.5mm unmated condition
- No reliance on noise cancellation, unlike some competitive products, which can be critical in high-speed applications
- 85-Ohm and 100-Ohm versions available

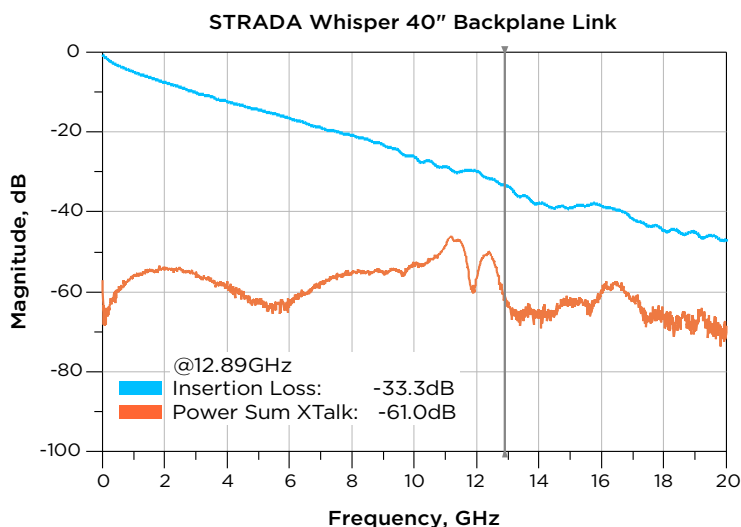

PRODUCT OFFERINGS

TE offers the STRADA Whisper product family in three versions: standard, orthogonal (for mid-plane structures) and a cabled version that allows you to run longer distances with lower insertion loss than PCB materials.

- Backplane Configuration
 - » 4.5mm right-angle receptacle
 - » 4.5mm vertical header
 - » 3.9mm right-angle receptacle
 - » 3.9mm vertical header
- Orthogonal Midplane configuration
 - » 3.9mm orthogonal right-angle receptacle
 - » 3.9mm orthogonal header
- Cable Assemblies
 - » 3.9mm cable assembly
- Embedded Cap Receptacles (in development)

4.5mm products are offered in 100 Ohm and 3.9mm configurations are offered in 85- and 100-Ohm versions.

Support Tools:
[S-parameter Models](#)
[Routing Designs](#)
[Application Instructions](#)

Related Links:
[DesignCon Papers](#)
[Micro Action Pin Papers](#)

Mechanical

RECEPTACLE

HEADER ASSEMBLY



Six ground connection points

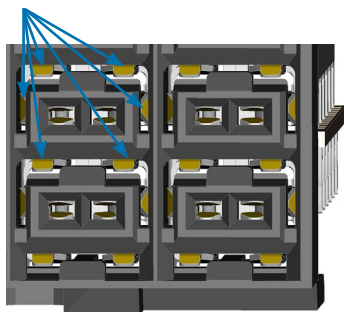
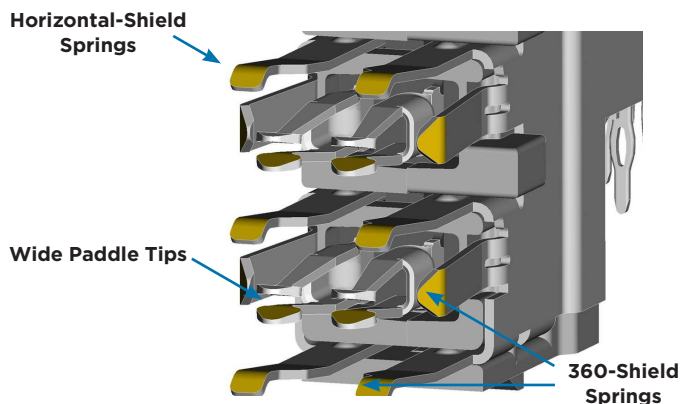

Fig. 1. Close up of signal contacts

Signal contacts are arranged horizontally in high-speed differential pairs for zero skew. This makes your board design simpler, while increasing signal integrity performance and saving board space. Each differential pair is surrounded by six ground connection points.

Connector allows for 1.5mm worth of mating separation (between both the ground and signal) through TE's patented C-shaped, 360-grounding design, which includes an extra "orphan" shield at the bottom of the horizontal stack of contacts for complete shielding. The 360-ground shield provides high signal integrity margin, (electrical margin) granting you more chip and PCB flexibility.

C-shaped shields protrude outwards to protect signal pins from damage.



Tabs on the sides of C-shield assure that ground contacts have at least a 2.5mm wipe, which helps maintain electrical performance with 1.5mm of unmated condition.

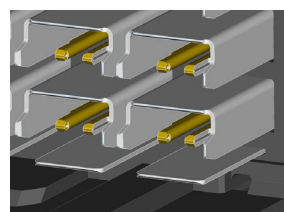

For More Information

www.te.com/products/stradawhisper

TE Technical Support Center

USA: +1 (800) 522-6752
Canada: +1 (905) 475-6222
Mexico: +52 (0) 55-1106-0800
Latin/S. America: +54 (0) 11-4733-2200
Germany: +49 (0) 6251-133-1999
UK: +44 (0) 800-267666
France: +33 (0) 1-3420-8686
Netherlands: +31 (0) 73-6246-999
China: +86 (0) 400-820-6015

te.com

© 2014 TE Connectivity Ltd. family of companies. All Rights Reserved. STRADA Whisper, TE Connectivity, TE Connectivity (logo) and Every Connection Counts are trademarks.

6-1773465-0 DTC

Компания «Life Electronics» занимается поставками электронных компонентов импортного и отечественного производства от производителей и со складов крупных дистрибьюторов Европы, Америки и Азии.

С конца 2013 года компания активно расширяет линейку поставок компонентов по направлению коаксиальный кабель, кварцевые генераторы и конденсаторы (керамические, пленочные, электролитические), за счёт заключения дистрибьюторских договоров

Мы предлагаем:

- Конкуренспособные цены и скидки постоянным клиентам.
- Специальные условия для постоянных клиентов.
- Подбор аналогов.
- Поставку компонентов в любых объемах, удовлетворяющих вашим потребностям.
- Приемлемые сроки поставки, возможна ускоренная поставка.
- Доставку товара в любую точку России и стран СНГ.
- Комплексную поставку.
- Работу по проектам и поставку образцов.
- Формирование склада под заказчика.
- Сертификаты соответствия на поставляемую продукцию (по желанию клиента).
- Тестирование поставляемой продукции.
- Поставку компонентов, требующих военную и космическую приемку.
- Входной контроль качества.
- Наличие сертификата ISO.

В составе нашей компании организован Конструкторский отдел, призванный помогать разработчикам, и инженерам.

Конструкторский отдел помогает осуществить:

- Регистрацию проекта у производителя компонентов.
- Техническую поддержку проекта.
- Защиту от снятия компонента с производства.
- Оценку стоимости проекта по компонентам.
- Изготовление тестовой платы монтаж и пусконаладочные работы.



Тел: +7 (812) 336 43 04 (многоканальный)
Email: org@lifeelectronics.ru