

MOD-VGA and MOD-VGA-32 USER'S MANUAL

Document revision B, June 2016
Designed by OLIMEX Ltd, 2012



All boards produced by Olimex LTD are ROHS compliant

DISCLAIMER

© 2016 Olimex Ltd. Olimex®, logo and combinations thereof, are registered trademarks of Olimex Ltd. Other product names may be trademarks of others and the rights belong to their respective owners.

The information in this document is provided in connection with Olimex products. No license, express or implied or otherwise, to any intellectual property right is granted by this document or in connection with the sale of Olimex products.

The Hardware project is released under the Creative Commons Attribution-Share Alike 3.0 United States License. You may reproduce it for both your own personal use, and for commercial use. You will have to provide a link to the original creator of the project <http://www.olimex.com> on any documentation or website. You may also modify the files, but you must then release them as well under the same terms. Credit can be attributed through a link to the creator website: <http://www.olimex.com>

The software is released under GPL.

It is possible that the pictures in this manual differ from the latest revision of the board.

The product described in this document is subject to continuous development and improvements. All particulars of the product and its use contained in this document are given by OLIMEX in good faith. However all warranties implied or expressed including but not limited to implied warranties of merchantability or fitness for purpose are excluded. This document is intended only to assist the reader in the use of the product. OLIMEX Ltd. shall not be liable for any loss or damage arising from the use of any information in this document or any error or omission in such information or any incorrect use of the product.

This evaluation board/kit is intended for use for engineering development, demonstration, or evaluation purposes only and is not considered by OLIMEX to be a finished end-product fit for general consumer use. Persons handling the product must have electronics training and observe good engineering practice standards. As such, the goods being provided are not intended to be complete in terms of required design-, marketing-, and/or manufacturing-related protective considerations, including product safety and environmental measures typically found in end products that incorporate such semiconductor components or circuit boards.

Olimex currently deals with a variety of customers for products, and therefore our arrangement with the user is not exclusive. Olimex assumes no liability for applications assistance, customer product design, software performance, or infringement of patents or services described herein.

THERE IS NO WARRANTY FOR THE DESIGN MATERIALS AND THE COMPONENTS USED TO CREATE MOD-VGA. THEY ARE CONSIDERED SUITABLE ONLY FOR MOD-VGA.

Table of Contents

<u>DISCLAIMER.....</u>	<u>2</u>
<u>CHAPTER 1: OVERVIEW.....</u>	<u>5</u>
<u>1. Introduction to the chapter.....</u>	<u>5</u>
<u>1.1 Features.....</u>	<u>5</u>
<u>1.2 Target market and purpose of the board.....</u>	<u>6</u>
<u>1.3 Organization.....</u>	<u>6</u>
<u>CHAPTER 2: SETTING UP THE MOD-VGA BOARD.....</u>	<u>7</u>
<u>2. Introduction to the chapter.....</u>	<u>7</u>
<u>2.1 Electrostatic warning.....</u>	<u>7</u>
<u>2.3 Requirements.....</u>	<u>7</u>
<u>2.4 Powering the board.....</u>	<u>8</u>
<u>2.5 Running an example using Olimex OLIMEXINO-328.....</u>	<u>8</u>
<u>CHAPTER 3: MOD-VGA BOARD DESCRIPTION.....</u>	<u>9</u>
<u>3. Introduction to the chapter.....</u>	<u>9</u>
<u>3.1 Layout (top view).....</u>	<u>9</u>
<u>3.2 Layout (bottom view).....</u>	<u>10</u>
<u>CHAPTER 4: The XILINX SPARTAN-3 XC3S200 FPGA.....</u>	<u>11</u>
<u>4. Introduction to the chapter.....</u>	<u>11</u>
<u>4.1 The XILINX SPARTAN-3 XC3S200 FPGA.....</u>	<u>11</u>
<u>CHAPTER 6: CONNECTORS, HARDWARE, PINOUTS.....</u>	<u>13</u>
<u>6. Introduction to the chapter.....</u>	<u>13</u>
<u>6.1 FPGA programming options.....</u>	<u>13</u>
<u>6.1.1 SPI PGM pinholes.....</u>	<u>13</u>
<u>6.1.2 JTAG pinholes.....</u>	<u>14</u>
<u>6.2 UEXT connector.....</u>	<u>14</u>
<u>6.3 Audio connector.....</u>	<u>15</u>
<u>6.4 VGA video connector.....</u>	<u>15</u>
<u>6.5 Arduino shield connector.....</u>	<u>16</u>
<u>6.6 Keyboard connector.....</u>	<u>17</u>
<u>6.7 Jumper description.....</u>	<u>17</u>
<u>6.7.1 5V/3V.....</u>	<u>17</u>
<u>6.7.2 SJ1.....</u>	<u>17</u>
<u>CHAPTER 8: SCHEMATICS.....</u>	<u>18</u>
<u>8. Introduction to the chapter.....</u>	<u>18</u>
<u>8.1 Eagle schematic.....</u>	<u>18</u>
<u>8.2 Physical dimensions.....</u>	<u>20</u>
<u>CHAPTER 9: REVISION HISTORY AND SUPPORT.....</u>	<u>21</u>
<u>9. Introduction to the chapter.....</u>	<u>21</u>

9.1 Document revision.....21
9.2 Board revision.....21
9.3 Useful web links and purchase codes.....22
9.4 Product support.....23

CHAPTER 1: OVERVIEW

1. Introduction to the chapter

Thank you for choosing the MOD-VGA video shield from Olimex! This document provides a user's guide for the Olimex MOD-VGA. As an overview, this chapter gives the scope of this document and lists the board's features. The document's organization is then detailed.

The MOD-VGA development board enables code development of applications running on the FPGA from the SPARTAN-3A family, manufactured by XLINIX.

MOD-VGA is an open-source, open-hardware project and all documentation is available to the customer. It is tested and working with OLIMEX AVR boards.

1.1 Features

MOD-VGA is a game adapter for the Arduino – or anything else with an SPI interface – built as a single shield that stacks up on top of the Arduino and has plugs for a VGA monitor and stereo speakers. The board is based on the open-source, open-hardware GAMEDUINO project by *excamera*. For more information on the original project please visit <http://excamera.com/sphinx/gameduino/>.

- Video output is 400x300 pixels in 512 colors
 - all color processed internally at 15-bit precision
 - compatible with any standard VGA monitor (800x600 @ 72Hz)
 - background graphics
 - 512x512 pixel character background
 - 256 characters, each with independent 4 color palette
 - pixel-smooth X-Y wraparound scroll
 - foreground graphics
 - each sprite is 16x16 pixels with per-pixel transparency
 - each sprite can use 256, 16 or 4 colors
 - four-way rotate and flip
 - 96 sprites per scan-line, 1536 texels per line
 - pixel-perfect sprite collision detection
- Audio output is a stereo 12-bit frequency synthesizer
 - 64 independent voices 10-8000 Hz
 - per-voice sine wave or white noise
 - sample playback channel

1.2 Target market and purpose of the board

The board follows the Arduino shield connector platform and can be mounted directly on 3.3V Arduino boards. Note that if your Arduino board doesn't have 3.3V operating mode you would need level shifter. The board comes with examples and libraries compatible with Arduino IDE (after importing the library and the examples provided on our web-site in Arduino).

The board is tested and working with our OLIMEXINO-328:

<https://www.olimex.com/Products/Duino/AVR/OLIMEXINO-328/open-source-hardware>.

The board has hardware compatibility with any 3.3V Arduino-like board and also Maple boards, Duinomite boards, and basically every board that follows the Arduino shield connector platform and can operate at 3.3V. However, the software support for all boards except for the Arduino-compatible AVR ones is not still implemented and might require extended software knowledge to be implemented.

Customers have full access to the technical documentation of the board. The software is released under General Purpose License and the board is considered open-hardware.

1.3 Organization

Each section in this document covers a separate topic, organized as follow:

- Chapter 1 is an overview of the board usage and features
- Chapter 2 provides a guide for quickly setting up the board and software notes
- Chapter 3 contains the general board diagram and layout
- Chapter 4 describes the component that is the heart of the board: the XILINX Spartan-3A FPGA
- Chapter 5 is an explanation of the control circuitry associated with the microcontroller to reset. Also shows the clocks on the board
- Chapter 6 covers the connector pinout, peripherals and jumper description
- Chapter 7 shows the memory map
- Chapter 8 provides the schematics
- Chapter 9 contains the revision history, useful links and support information

CHAPTER 2: SETTING UP THE MOD-VGA BOARD

2. Introduction to the chapter

This section helps you set up the MOD-VGA development board for the first time. Please consider first the electrostatic warning to avoid damaging the board, then discover the hardware and software required to operate the board.

The procedure to power up the board is given, and a description of the default board behavior is detailed.

2.1 Electrostatic warning

MOD-VGA is shipped in a protective anti-static package. The board must not be exposed to high electrostatic potentials. A grounding strap or similar protective device should be worn when handling the board. Avoid touching the component pins or any other metallic element.

2.3 Requirements

In order to set up the MOD-VGA optimally, the following items are required (separated in hardware and software requirements).

Hardware:

- Host board with Arduino platform connectors (For example OLIMEXINO-328 or OLIMEXINIO-32U4) that can operate at 3.3V (or level shifter)
- VGA monitor
- PS2 keyboard (that can operate at 5V or 3V)
- Audio output device

Software:

- Arduino-IDE
- A library that needs to be imported in Arduino-IDE and can be found at our web-site at MOD-VGA's page

2.4 Powering the board

The board gets powered when mounted on compatible Arduino board by 3.3V.

Important: MOD-VGA is not 5V tolerant.

The SPI lines coming from the main board go to the XYLNIX SPARTAN-3A chip via 47 Ohm resistors and the GPIO pins of SPARTAN-3A have an absolute maximum of 4.6V!

2.5 Running an example using Olimex OLIMEXINO-328

First place properly the library for Arduino that can be found on the device's web page:
<https://www.olimex.com/Products/Modules/Interface/MOD-VGA/>

Make sure that the OLIMEXINO-328 board operates at 3.3V! There is a switch that modifies the operating voltage of the board – either 3.3V or 5V operation.

Then start Arduino and open the corresponding to OLIMEXINO-328 board configuration:

Tools -> Board -> Arduino Duemilanove w\ATmega 328

Then program for example:

Files -> Examples -> Gameduino -> Audio -> player

We should see a graphic and there should be sound (if we have audio output device connected).

CHAPTER 3: MOD-VGA BOARD DESCRIPTION

3. Introduction to the chapter

Here you get acquainted with the main parts of the board. Note the names used on the board might differ from the names used below to describe them. For the actual names check the MOD-VGA board itself.

3.1 Layout (top view)

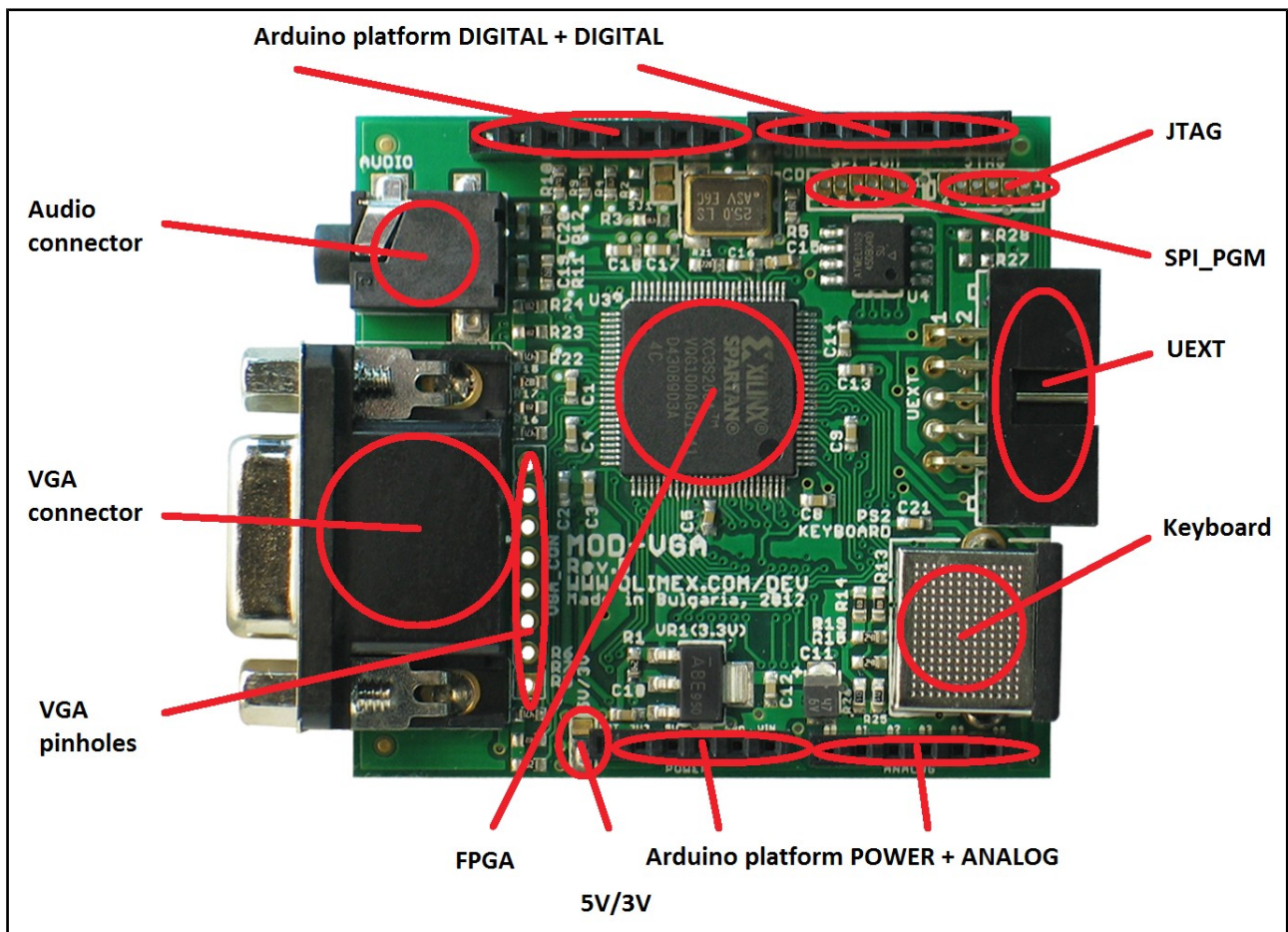

3.2 Layout (bottom view)

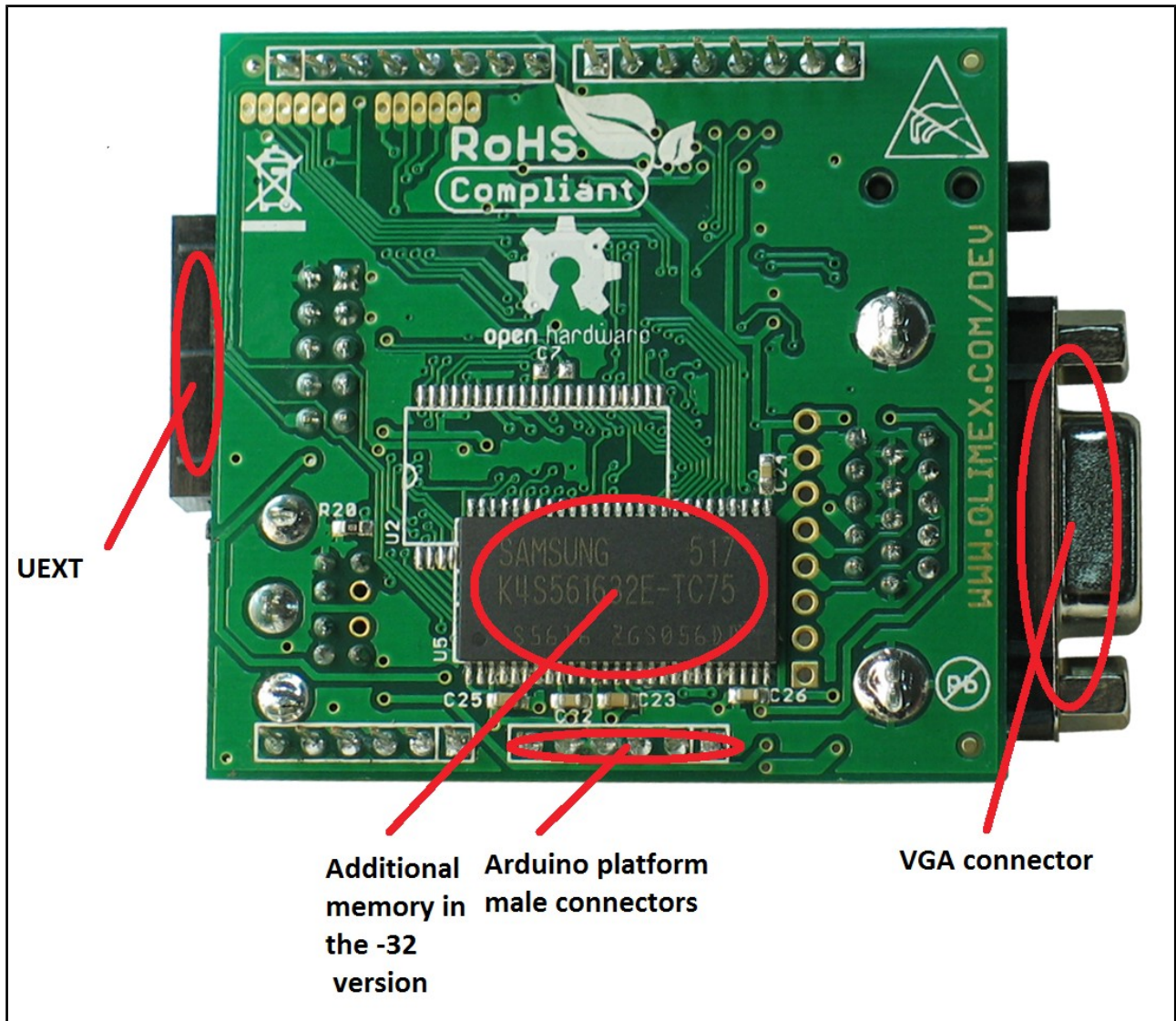

Note the base MOD-VGA version doesn't have the additional memory present on the picture of MOD-VGA-32.

CHAPTER 4: The XILINX SPARTAN-3 XC3S200 FPGA

4. Introduction to the chapter

In this chapter is located the information about the heart of MOD-VGA – its controller. The information is a modified version of the datasheet provided by its manufacturers.

4.1 The XILINX SPARTAN-3 XC3S200 FPGA

- Low-cost, high-performance logic solution for high-volume, consumer-oriented applications
 - ✓ 4320 logic cells
- SelectIO™ interface signaling
 - ✓ 173 I/O pins
 - ✓ 622+ Mb/s data transfer rate per I/O
 - ✓ 18 single-ended signal standards
 - ✓ 8 differential I/O standards including LVDS, RSDS
 - ✓ Termination by Digitally Controlled Impedance
 - ✓ Signal swing ranging from 1.14V to 3.465V
 - ✓ Double Data Rate (DDR) support
 - ✓ DDR, DDR2 SDRAM support up to 333 Mbps
- Logic resources
 - ✓ Abundant logic cells with shift register capability
 - ✓ Wide, fast multiplexers
 - ✓ Fast look-ahead carry logic
 - ✓ Dedicated 18 x 18 multipliers
 - ✓ JTAG logic compatible with IEEE 1149.1/1532
- SelectRAM™ hierarchical memory
 - ✓ 216 Kbits of total block RAM
 - ✓ 30 Kbits of total distributed RAM
- Digital Clock Manager (up to four DCMs)
 - ✓ Clock skew elimination
 - ✓ Frequency synthesis
 - ✓ High resolution phase shifting
- Eight global clock lines and abundant routing
 - ✓ Fully supported by Xilinx ISE® and WebPACK™ software development systems
 - ✓ MicroBlaze™ and PicoBlaze™ processor, PCI®, PCIExpress® PIPE Endpoint, and other IP cores
 - ✓ Pb-free packaging options
 - ✓ Automotive Spartan-3 XA Family variant

For comprehensive information on the microcontroller visit the Xilinx's web page for a datasheet.

At the moment of writing the FPGA's datasheet can be found at the following link:

http://www.xilinx.com/support/documentation/data_sheets/ds099.pdf

CHAPTER 6: CONNECTORS, HARDWARE, PINOUTS

6. Introduction to the chapter

In this chapter are presented the connectors that can be found on the board all together with their pinout and notes about them. Jumpers functions are described. Notes and info on specific peripherals are presented. Notes regarding the interfaces are given.

6.1 FPGA programming options

There are couple of options provided for programming the Xilinx FPGA. Both of them are located near the DIGITAL connector from the Arduino platform. Note that both of them lack headers. The SPI_PGM and JTAG are discussed below.

6.1.1 SPI_PGM pinholes

The SPI_PGM interface lacks connector. You can mount for instance WU06S for easier interfacing.

SPI_PGM	
PIN#	SIGNAL NAME
1	FLASH_SO
2	FLASH_SI
3	FLASH_SCK
4	#FLASH_CS
5	GND
6	+3.3V

6.1.2 JTAG pinholes

The JTAG interface lacks connector. You can mount plastic header (for instance WU06S) for easier interfacing.

JTAG	
PIN#	SIGNAL NAME
1	+3.3V
2	TCK
3	TDO
4	TMS
5	TDI
6	GND

6.2 UEXT connector

Note that the signals on the UEXT connector are multiplexed with the respective header pins from the Arduino shield connector.

Note that the SPI interface can also be found on the Arduino shield connector.

For more info on the UEXT connector please visit:

<https://www.olimex.com/Products/Modules/UEXT/>

UEXT connector		
Pin #	Signal Name	Processor Pin #
1	+3.3V	-
2	GND	-
3	Not Connected	-
4	INT	78
5	Not Connected	-
6	INT	78
7	UEXT_MISO	86
8	UEXT_MOSI	85
9	UEXT_CLK	84
10	UEXT_SSEL	88

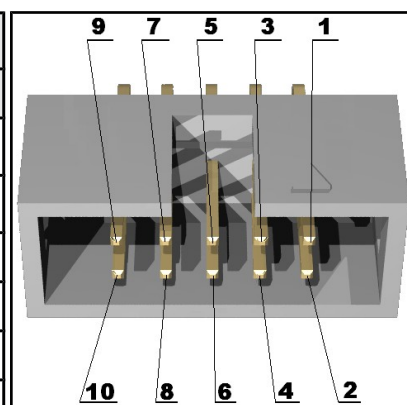

6.3 Audio connector

Standard audio jack and phone jack are mounted for the audio interfacing.

Headphones/Audio out connector		
Pin#	SIGNAL NAME	Processor Pin#
1	LINE_OUT_L	99
3	LINE_OUT_R	98
2	GND	GND pins

The headphones resistance is 16 Ohms!

6.4 VGA video connector

The female DA-15 connector is used for video output on a monitor.

Note that there is also a row of pinholes near the DA-15 named VGA_CON – it gives access to the used signals only. Check the tables below for pinout of both the DB15 and the VGA_CON.

VGA_CON	
PIN#	SIGNAL
1	VGA_R
2	VGA_G
3	VGA_B
4	H_SYNC
5	V_SYNC
6	+5V
7	GND
8	+3.3V

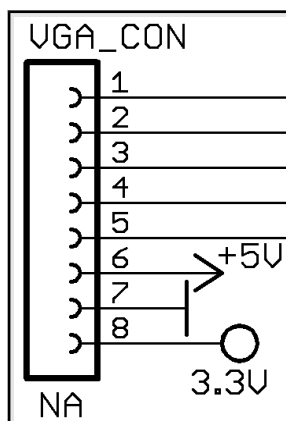

You may find the pinout of the DA-15 connector on the next page.

VGA DB15 connector			
GPIO Pin#	Signal Name	GPIO Pin#	Signal Name
1	VGA_R	2	VGA_G
3	VGA_B	4	Not Connected
5	GND	6	GND
7	GND	8	GND
9	GND	10	GND
11	Not Connected	12	Not Connected
13	VGA_HSYNC	14	VGA_VSYNC
15	Not Connected	16	Not Connected

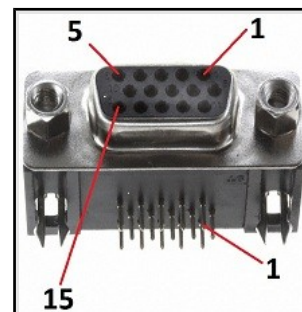

6.5 Arduino shield connector

Pad Name	Signal	Pad Name	Signal
POWER		ANALOG	
RST	Not connected	A0	Not connected
3V3	3V3	A1	Not connected
5V	5V	A2	Not connected
GND	GROUND	A3	Not connected
GND	GROUND	A4	Not connected
VIN	Not connected	A5	Not connected
DIGITAL #1		DIGITAL #2	
D0	Not connected	D8	Not connected
D1	Not connected	D9	UEXT_SSEL
D2	INT	D10	SPI_CS
D3	Not connected	D11	SPI_MOSI
D4	Not connected	D12	SPI_MISO
D5	Not connected	D13	SPI_CLK
D6	PS2_DATA	GND	Not connected
D7	PS2_CLK	AREF	Not connected

6.6 Keyboard connector

The key board connector is a standard PS2 one requiring MINI-DIN cable connector. By default it operates at 5V. The voltage available for the keyobard can be changed by modifying jumper 5V/3V.

6.7 Jumper description

Please note that both jumpers on the board are SMT type. If you feel insecure of your soldering/cutting technique it is better not to try to adjust the jumpers.

6.7.1 5V/3V

Those jumpers control the voltage available at the PS2 keyboard connector.

The default position is 5V.

6.7.2 SJ1

SJ1 jumper controls whether SPI SSEL line that is available on the UEXT pin #10 is also connected to pin D9 from the digital connector of the Arduino interface. If the jumper is connected then the mentioned multiplexing is present.

The default position is closed (SPI CS is available simultaneously at pin #10 of the UEXT connector and at pin D9 from the Arduino shield connector).

CHAPTER 8: SCHEMATICS

8. Introduction to the chapter

In this chapter are located the schematics describing logically and physically MOD-VGA.

8.1 Eagle schematic

The EAGLE schematic is situated on the next page for quicker reference. It can also be found on the web-page of the device. The schematic and board files are released under the Creative Commons Attribution-Share Alike 3.0 United States License. You may reproduce it for both your own personal use, and for commercial use. You will have to provide a link to the original creator of the project (<https://www.olimex.com>) on any documentation or website.

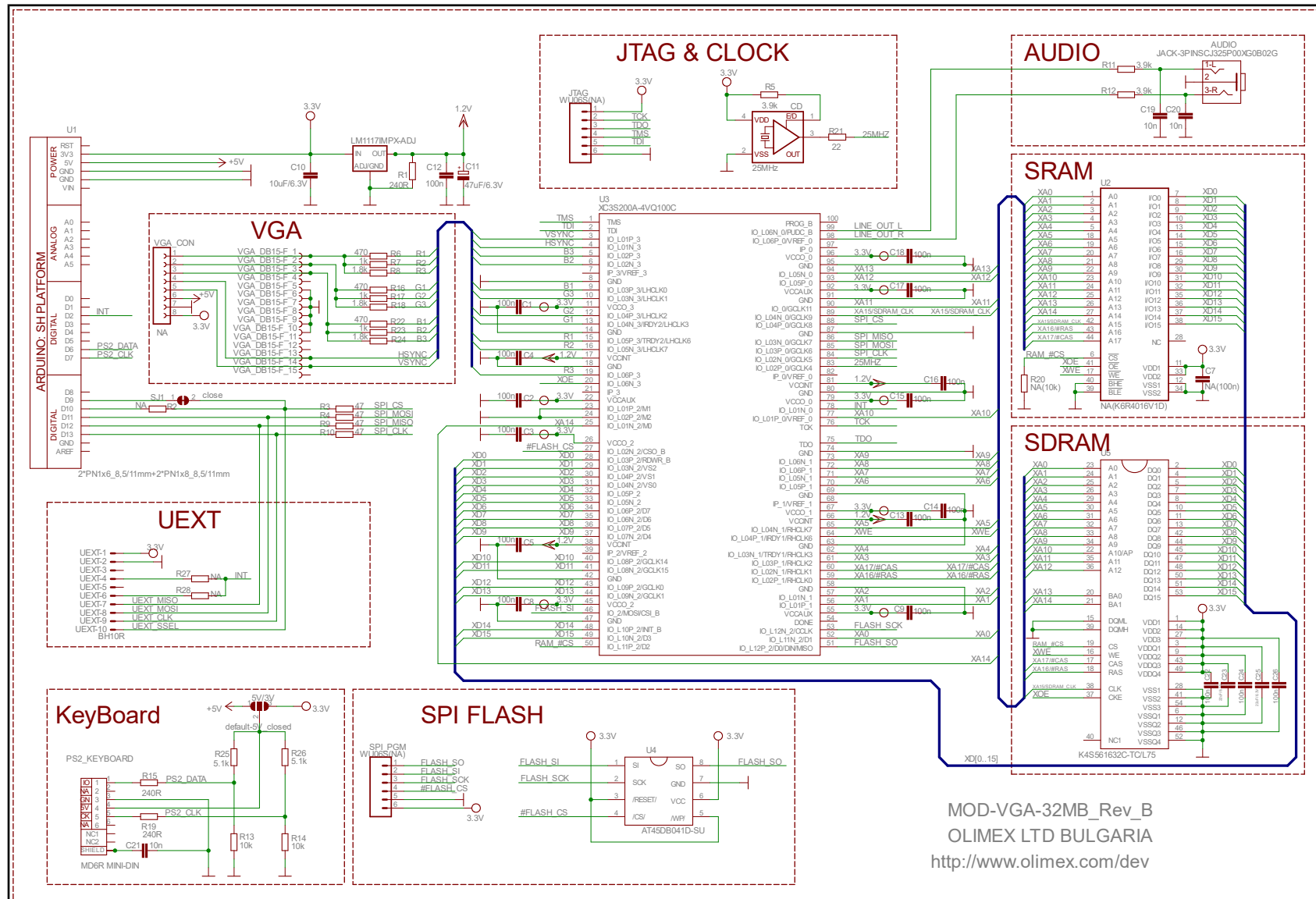

MOD-VGA-32MB_Rev_B
 OLIMEX LTD BULGARIA
<http://www.olimex.com/dev>

8.2 Physical dimensions

Note that all dimensions are in mil.

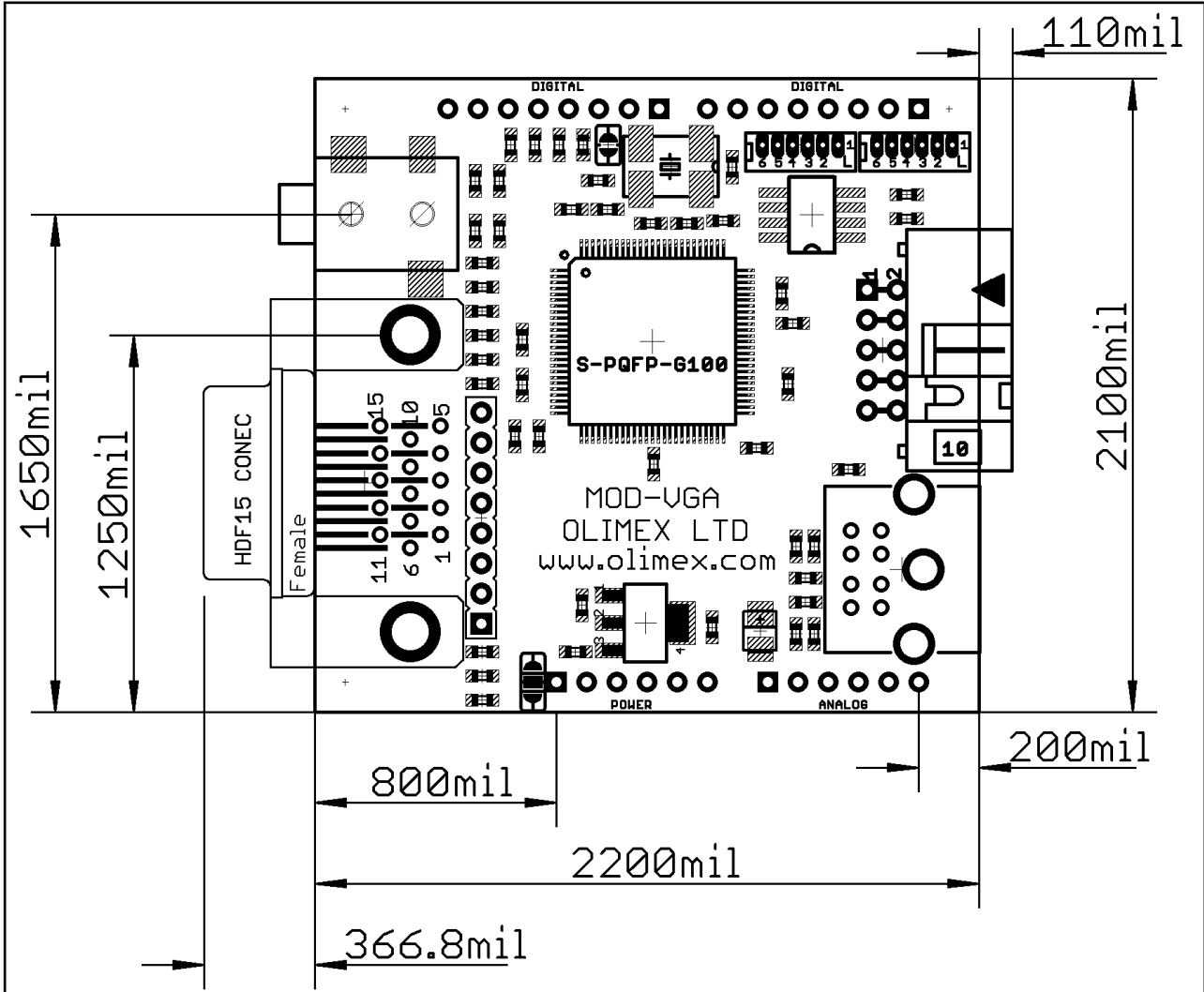

The two highest elements on the board are: VGA connector – 500mil; KEYBOARD connector – 500mil

CHAPTER 9: REVISION HISTORY AND SUPPORT

9. Introduction to the chapter

In this chapter you will find the current and the previous version of the document you are reading. Also the web-page for your device is listed. Be sure to check it after a purchase for the latest available updates and examples.

9.1 Document revision

Revision	Changes	Modified Page#
A, 29.10.12	Initial Creation	All
B, 17.06.16	Fixed wrong descripton of 5V/3V jumper. Clarified that the shield is not 5V-compatible. Various formatting fixes	All

9.2 Board revision

Revision	Notable Changes
B	Initial release of the board

9.3 Useful web links and purchase codes

More info on the shield can be found at the following web pages:

MOD-VGA: <https://www.olimex.com/Products/Modules/Interface/MOD-VGA/>

MOD-VGA-32: <https://www.olimex.com/Products/Modules/Interface/MOD-VGA-32MB/>

ORDER NAMES:

MOD-VGA – the standard/base version of MOD-VGA (GAMEDUINO project derivative)

MOD-VGA-32MB – the MOD-VGA version with additional memory

OLIMEXINO-328 – an Arduino compatible board tested and working out-of-the-box with MOD-VGA

OLIMEXINO-32U4 - a Leonardo-like Arduino compatible board

The latest price list can be found at <https://www.olimex.com/prices>.

How to order?

You can order directly from our web-shop or from any of our distributors.

Check <https://www.olimex.com/> for more info.

9.4 Product support

For product support, hardware information and error reports mail to: support@olimex.com. All document or hardware feedback is welcome. Note that we are primarily a hardware company and our software support is limited. Please consider reading the paragraph below about the warranty of Olimex products.

All goods are checked before they are sent out. In the unlikely event that goods are faulty, they must be returned, to OLIMEX at the address listed on your order invoice.

OLIMEX will not accept goods that have clearly been used more than the amount needed to evaluate their functionality.

If the goods are found to be in working condition, and the lack of functionality is a result of lack of knowledge on the customers part, no refund will be made, but the goods will be returned to the user at their expense.

All returns must be authorized by an RMA Number. Email support@olimex.com for authorization number before shipping back any merchandise. Please include your name, phone number and order number in your email request.

Returns for any unaffected development board, programmer, tools, and cables permitted within 7 days from the date of receipt of merchandise. After such time, all sales are considered final.

Returns of incorrect ordered items are allowed subject to a 10% restocking fee. What is unaffected? If you hooked it to power, you affected it. To be clear, this includes items that have been soldered to, or have had their firmware changed. Because of the nature of the products we deal with (prototyping electronic tools) we cannot allow returns of items that have been programmed, powered up, or otherwise changed post shipment from our warehouse.

All returned merchandise must be in its original mint and clean condition. Returns on damaged, scratched, programmed, burnt, or otherwise 'played with' merchandise will not be accepted.

All returns must include all the factory accessories which come with the item. This includes any In-Circuit-Serial-Programming cables, anti-static packing, boxes, etc.

With your return, enclose your PO#. Also include a brief letter of explanation of why the merchandise is being returned and state your request for either a refund or an exchange. Include the authorization number on this letter, and on the outside of the shipping box.

Please note: It is your responsibility to ensure that returned goods reach us. Please use a reliable form of shipping. If we do not receive your package we will not be held liable.

Shipping and handling charges are not refundable. We are not responsible for any shipping charges of merchandise being returned to us or returning working items to you.

The full text might be found at <https://www.olimex.com/wiki/GTC#Warranty> for future reference.

Компания «Life Electronics» занимается поставками электронных компонентов импортного и отечественного производства от производителей и со складов крупных дистрибьюторов Европы, Америки и Азии.

С конца 2013 года компания активно расширяет линейку поставок компонентов по направлению коаксиальный кабель, кварцевые генераторы и конденсаторы (керамические, пленочные, электролитические), за счёт заключения дистрибьюторских договоров

Мы предлагаем:

- Конкурентоспособные цены и скидки постоянным клиентам.
- Специальные условия для постоянных клиентов.
- Подбор аналогов.
- Поставку компонентов в любых объемах, удовлетворяющих вашим потребностям.
- Приемлемые сроки поставки, возможна ускоренная поставка.
- Доставку товара в любую точку России и стран СНГ.
- Комплексную поставку.
- Работу по проектам и поставку образцов.
- Формирование склада под заказчика.
- Сертификаты соответствия на поставляемую продукцию (по желанию клиента).
- Тестирование поставляемой продукции.
- Поставку компонентов, требующих военную и космическую приемку.
- Входной контроль качества.
- Наличие сертификата ISO.

В составе нашей компании организован Конструкторский отдел, призванный помогать разработчикам, и инженерам.

Конструкторский отдел помогает осуществить:

- Регистрацию проекта у производителя компонентов.
- Техническую поддержку проекта.
- Защиту от снятия компонента с производства.
- Оценку стоимости проекта по компонентам.
- Изготовление тестовой платы монтаж и пусконаладочные работы.



Тел: +7 (812) 336 43 04 (многоканальный)

Email: org@lifeelectronics.ru