

## Carbon Monoxide Detector Companion IC

### Features

- Low Quiescent Current
- Operation from 2V or 12V
- 9.8V Boost Regulator
- Horn Driver
- LED Driver
- 3.3V Regulated Voltage for Microcontroller Operation
- Internal Operational Amplifiers:
  - $\pm 1$  mV Input Offset Voltage
  - Rail-to-Rail Input and Output
  - 10 kHz Gain Bandwidth Product
  - Unity Gain Stable
- Bidirectional Alarm Interconnect

### Applications

- CO Detector
- Toxic Gas Detector
- Heat Detector

### Description

The RE46C800 is a low power CMOS carbon monoxide detector companion IC. The RE46C800 provides all of the analog, interface, and power management functions for a microcontroller-based CO or toxic gas detector. It is intended for use in both 3V and 9V battery or battery-backed applications. It features a boost regulator and horn driver circuit suitable for driving a piezoelectric horn, a 3.3V regulator for microcontroller voltage regulation, an LED driver, an operational amplifier and an IO for communication with interconnected units.

### Package Types

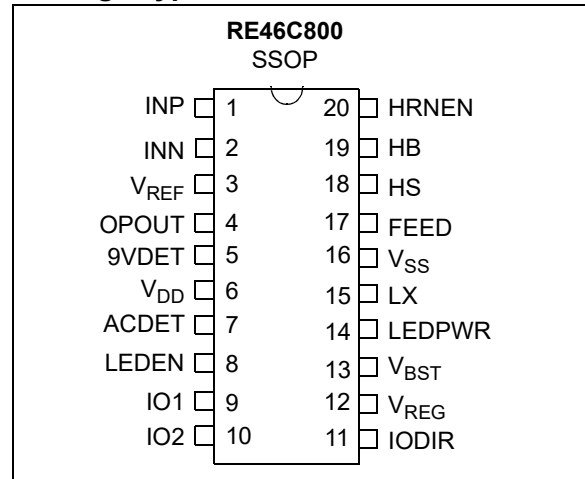

# RE46C800

## Functional Block Diagram

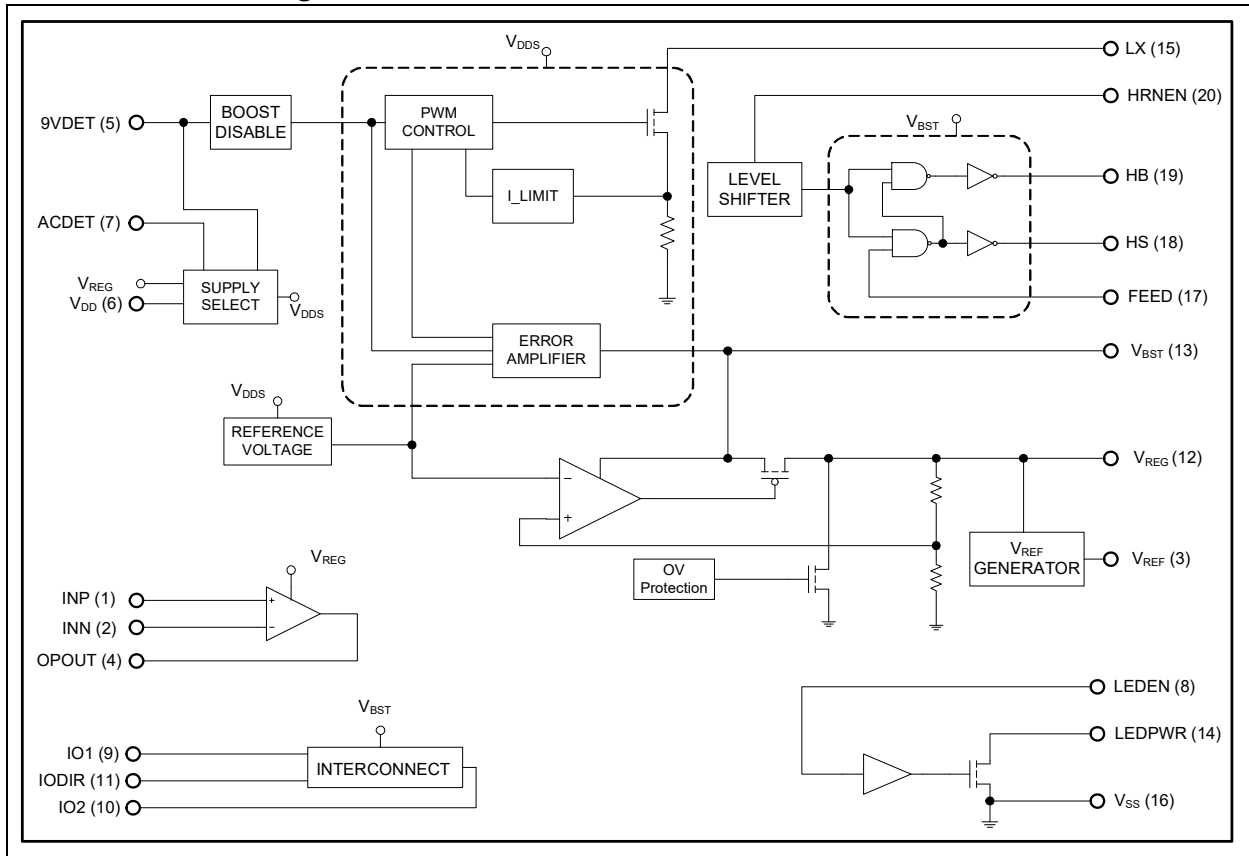

## 1.0 ELECTRICAL CHARACTERISTICS

### 1.1 Absolute Maximum Ratings†

V <sub>DD</sub> .....	-0.3V to 5.5V
ESD HBM.....	1500V
ESD MM.....	150V
V <sub>BST</sub> , LX.....	-0.3V to 13V
Input Voltage Range Except ACDET, 9VDET, FEED, IO1 .....	V <sub>IN1</sub> = - .3V to V <sub>REG</sub> + .3V
ACDET, 9VDET Input Voltage Range .....	V <sub>IN2</sub> = - .3V to V <sub>BST</sub> + .3V
FEED Input Voltage Range .....	V <sub>INFD</sub> = -10V to + 22V
IO1 Input Voltage Range.....	V <sub>INIO1</sub> = - .3 to +15V
Input Current except FEED.....	I <sub>IN</sub> = 10 mA
Operating Temperature .....	T <sub>A</sub> = -10°C to +60°C
Storage Temperature .....	T <sub>STG</sub> = -55°C to +125°C
Maximum Junction Temperature .....	T <sub>J</sub> = +150°C

† **Notice:** Stresses above those listed under “Maximum Ratings” may cause permanent damage to the device. This is a stress rating only and functional operation of the device at these or any other conditions above those indicated in the operation listings of this specification is not implied. Exposure to maximum rating conditions for extended periods may affect device reliability.

### DC ELECTRICAL CHARACTERISTICS – RE46C800

**Unless otherwise indicated,** all parameters apply at T<sub>A</sub> = -10°C to +60°C, V<sub>DD</sub> = 3V, V<sub>SS</sub> = 0V, C<sub>REG</sub> = 10 μF, C<sub>BST</sub> = 10 μF, 9VDET low, ACDET low. (Note 1) (Note 2) (Note 3)

Parameter	Symbol	Test Pin	Min.	Typ.	Max.	Units	Conditions
Supply Voltage	V <sub>DD</sub>	6	2	—	5	V	Operating
	V <sub>BST</sub>	13	6	—	12	V	Operating, 9V operation, 9VDET or ACDET high
Standby Supply Current	I <sub>DDSTBY1</sub>		—	13.6	—	μA	Inputs low; No loads, boost regulator running (Note 4)
	I <sub>DDSTBY2</sub>		—	5.8	9.3	μA	Inputs low; No loads, boost regulator disabled, 9V operation, V <sub>BST</sub> = 9V, 9VDET high
Quiescent Supply Current	I <sub>DDQ</sub>	6	—	6.8	10.3	μA	Inputs low; No loads; V <sub>BST</sub> = 5V; V <sub>LX</sub> = 0.5V
Quiescent I <sub>VO</sub>	I <sub>VOQ</sub>	13	—	3.6	5.2	μA	Inputs low; No loads; V <sub>BST</sub> = 5V; V <sub>LX</sub> = 0.5V

- Note** 1: Wherever a specific V<sub>BST</sub> value is listed under test conditions, the V<sub>BST</sub> is forced externally with the inductor disconnected and the boost regulator is NOT running.
- 2: Typical values are for design information only.
- 3: The limits shown are 100% tested at 25°C only. Test limits are guard-banded based on temperature characterization to warrant compliance at temperature extremes.
- 4: The Standby Supply Current I<sub>DDSTBY1</sub> specified above can be approximated as follows:
- $$I_{DDSTBY1} = I_{DDQ} + I_{IND}$$
- Where I<sub>DDQ</sub> = average current into V<sub>DD</sub> supply
- $$I_{IND} = \text{average inductor current} = V_{BST} * I_{VOQ} / (V_{IN} * \text{Efficiency})$$
- $$V_{IN} = V_{DD} = 3V$$

# RE46C800

## DC ELECTRICAL CHARACTERISTICS – RE46C800 (CONTINUED)

Unless otherwise indicated, all parameters apply at  $T_A = -10^{\circ}\text{C}$  to  $+60^{\circ}\text{C}$ ,  $V_{DD} = 3\text{V}$ ,  $V_{SS} = 0\text{V}$ ,  $C_{REG} = 10\ \mu\text{F}$ ,  $C_{BST} = 10\ \mu\text{F}$ , 9VDET low, ACDET low. (Note 1) (Note 2) (Note 3)

Parameter	Symbol	Test Pin	Min.	Typ.	Max.	Units	Conditions
Input Leakage Low	$I_{IL}$	1, 5, 7, 8, 10, 11, 20	—	—	-100	nA	INP, 9VDET, ACDET, LEDEN, IO2, IODIR, HRNEN Inputs $V_{IN} = V_{SS}$
	$I_{ILOP}$	2	—	—	-200	pA	INN input, $V_{IN} = V_{SS}$
	$I_{ILF}$	17	—	-15	-50	$\mu\text{A}$	FEED = -10V, $V_{BST} = 10\text{V}$
Input Leakage High	$I_{IH1}$	1, 8, 10, 11, 20	—	—	100	nA	INP, LEDEN, IO2, IODIR, HRNEN Inputs $V_{IN} = V_{REG}$
	$I_{IH2}$	5, 7	—	—	100	nA	9VDET, ACDET Inputs, $V_{IN} = V_{BST}$ , $V_{BST} = 10\text{V}$ .
	$I_{IHOP}$	2	—	—	200	pA	INN input, $V_{IN} = V_{REG}$
	$I_{IHF}$	17	—	20	50	$\mu\text{A}$	FEED = +22V; $V_{BST} = 10\text{V}$
Output Off Leakage High	$I_{IHOZ}$	14, 15	—	—	1	$\mu\text{A}$	LEDEN = $V_{SS}$ , LEDPWR, LX = $V_{BST} = 10\text{V}$
Input Voltage Low	$V_{IL1}$	8, 10, 11, 20	—	—	1	V	LEDEN, IO2, IODIR, HRNEN Inputs
	$V_{IL2}$	7	—	—	7	V	ACDET Input, $V_{BST} = 10\text{V}$
	$V_{IL3}$	5	—	—	4	V	9VDET Input, $V_{BST} = 10\text{V}$
	$V_{ILF}$	17	—	—	3	V	FEED Input; $V_{BST} = 10\text{V}$
	$V_{ILIO1}$	9	—	—	0.8	V	Falling edge of IO1 input, IODIR = $V_{SS}$
Input Voltage High	$V_{IH1}$	8, 10, 11, 20	$V_{REG} - .7$	—	—	V	LEDEN, IO2, IODIR, HRNEN Inputs
	$V_{IH2}$	7	8.2	—	—	V	ACDET Input, $V_{BST} = 10\text{V}$
	$V_{IH3}$	5	6	—	—	V	9VDET Input, $V_{BST} = 10\text{V}$
	$V_{IHF}$	17	7	—	—	V	FEED Input; $V_{BST} = 10\text{V}$
	$V_{IHIO1}$	9	2	—	—	V	Rising edge of IO1 input, IODIR = $V_{SS}$
Output Voltage Low	$V_{OL1}$	18, 19	—	—	0.5	V	HS or HB; $I_{OUT} = 16\ \text{mA}$ ; $V_{DD} = 3\text{V}$ ; $V_{BST} = 10\text{V}$ , HRNEN = $V_{SS}$
	$V_{OL2}$	14	—	—	0.5	V	LEDPWR; $I_{OUT} = 10\ \text{mA}$ ; $V_{BST} = 10\text{V}$
	$V_{OLIO2}$	10	—	—	0.5	V	IO2 output, $I_{OUT} = 100\ \mu\text{A}$ , IODIR = $V_{SS}$

- Note 1:** Wherever a specific  $V_{BST}$  value is listed under test conditions, the  $V_{BST}$  is forced externally with the inductor disconnected and the boost regulator is NOT running.
- Note 2:** Typical values are for design information only.
- Note 3:** The limits shown are 100% tested at  $25^{\circ}\text{C}$  only. Test limits are guard-banded based on temperature characterization to warrant compliance at temperature extremes.
- Note 4:** The Standby Supply Current  $I_{DDSTBY1}$  specified above can be approximated as follows:

$$I_{DDSTBY1} = I_{DDQ} + I_{IND}$$

Where  $I_{DDQ}$  = average current into  $V_{DD}$  supply

$$I_{IND} = \text{average inductor current} = V_{BST} * IVOQ / (V_{IN} * \text{Efficiency})$$

$$V_{IN} = V_{DD} = 3\text{V}$$

## DC ELECTRICAL CHARACTERISTICS – RE46C800 (CONTINUED)

Unless otherwise indicated, all parameters apply at  $T_A = -10^\circ\text{C}$  to  $+60^\circ\text{C}$ ,  $V_{DD} = 3\text{V}$ ,  $V_{SS} = 0\text{V}$ ,  $C_{REG} = 10\ \mu\text{F}$ ,  $C_{BST} = 10\ \mu\text{F}$ , 9VDET low, ACDET low. (Note 1) (Note 2) (Note 3)

Parameter	Symbol	Test Pin	Min.	Typ.	Max.	Units	Conditions
Output Voltage High	$V_{OH1}$	18, 19	9.5	—	—	V	HS or HB; $I_{OUT} = -16\ \text{mA}$ ; $V_{BST} = 10\text{V}$ ; $HRNEN = V_{REG}$
	$V_{OHIO1}$	9	3	—	—	V	IO1, $I_{OUT} = -4\ \text{mA}$ , $IODIR = V_{IH1}$ , $IO2 = V_{IH1}$
	$V_{OHIO2}$	10	$V_{REG} - .5$	—	—	V	IO2, $I_{OUT} = -100\ \mu\text{A}$ , $IODIR = V_{SS}$ , $IO1 = V_{IHIO1}$
Reference Voltage	$V_{REF}$	3	—	300	—	mV	
$V_{BST}$ Output Voltage	$V_{VO1}$	13	9	9.8	10.6	V	$V_{DD} = 3\text{V}$ ; $HRNEN = V_{REG}$ ; $I_{OUT} = 10\ \text{mA}$
	$V_{VO2}$	13	3.6	4	4.4	V	$V_{DD} = 3\text{V}$ ; $HRNEN = V_{SS}$ ; $I_{OUT} = 10\ \text{mA}$
$V_{BST}$ Efficiency	$V_{EFF1}$		—	85	—	%	$I_{LOAD} = 10\ \text{mA}$ ; $V_{DD} = 3\text{V}$ ; $HRNEN = V_{SS}$
	$V_{EFF2}$		—	75	—	%	$I_{LOAD} = 100\ \mu\text{A}$ ; $V_{DD} = 3\text{V}$ ; $HRNEN = V_{SS}$
$V_{REG}$ Voltage	$V_{REG}$	12	3.2	3.3	3.4	V	$I_{OUT} < 20\ \text{mA}$
$V_{REG}$ Load Regulation	$V_{REGLD}$	12	—	30	50	mV	$I_{OUT} = 0$ to $20\ \text{mA}$ ; $HRNEN = V_{REG}$
Brown-out Threshold	$V_{OBVT}$	13	3.2	3.6	4	V	Falling edge of $V_{BST}$
$V_{BST}$ -to-Brown-out Margin	$V_{OBVTM}$	13	100	400	—	mV	$V_{VO2} - V_{OBVT}$
Brown-out Pull Down	$I_{BT}$	12	20	40	—	mA	$V_{BST} = 3.0\text{V}$ ; $V_{REG} = 2.0\text{V}$
$V_{REG}$ Over Voltage Clamp	$V_{CL}$	12	3.75	4	4.25	V	
IO1 Output Current	$IO1_{IH1}$	9	25	—	60	$\mu\text{A}$	$IODIR = V_{SS}$ , $IO1 = 1\text{V}$
	$IO1_{IH2}$	9	—	—	150	$\mu\text{A}$	$IODIR = V_{SS}$ , $IO1 = 15\text{V}$
	$IO1_{IOH1}$	9	-4	-5	—	mA	$IODIR$ , $IO2 = V_{IH1}$ , $IO1 = 3\text{V}$
	$IO1_{IOH2}$	9	—	-5	-16	mA	$IODIR$ , $IO2 = V_{IH1}$ , $IO1 = V_{SS}$
	$IO1_{IOL1}$	9	—	10	—	mA	IO Dump Current, $IODIR = V_{IH1}$ , $IO2 = V_{SS}$ , $IO1 = 1\text{V}$
IO1 Hysteresis	$V_{HYSTIO1}$	9	—	150	—	mV	$IODIR = V_{SS}$
<b>Op Amp</b>							
Input Offset Voltage	$V_{OS}$	4	-1	—	1	mV	$V_{CM} = 0.3\text{V}$
Common Mode Input Range	$V_{CMR}$	1, 2	$V_{SS}$	—	$V_{REG}$	V	

**Note 1:** Wherever a specific  $V_{BST}$  value is listed under test conditions, the  $V_{BST}$  is forced externally with the inductor disconnected and the boost regulator is NOT running.

**2:** Typical values are for design information only.

**3:** The limits shown are 100% tested at  $25^\circ\text{C}$  only. Test limits are guard-banded based on temperature characterization to warrant compliance at temperature extremes.

**4:** The Standby Supply Current  $I_{DDSTBY1}$  specified above can be approximated as follows:

$$I_{DDSTBY1} = I_{DDQ} + I_{IND}$$

Where  $I_{DDQ}$  = average current into  $V_{DD}$  supply

$$I_{IND} = \text{average inductor current} = V_{BST} * I_{VOQ} / (V_{IN} * \text{Efficiency})$$

$$V_{IN} = V_{DD} = 3\text{V}$$

# RE46C800

## DC ELECTRICAL CHARACTERISTICS – RE46C800 (CONTINUED)

Unless otherwise indicated, all parameters apply at  $T_A = -10^{\circ}\text{C}$  to  $+60^{\circ}\text{C}$ ,  $V_{DD} = 3\text{V}$ ,  $V_{SS} = 0\text{V}$ ,  $C_{REG} = 10\ \mu\text{F}$ ,  $C_{BST} = 10\ \mu\text{F}$ , 9VDET low, ACDET low. (Note 1) (Note 2) (Note 3)

Parameter	Symbol	Test Pin	Min.	Typ.	Max.	Units	Conditions
Common Mode Rejection Ratio	CMRR	1, 2, 4	—	80	—	dB	$V_{REG} = 3.3\text{V}$ , $V_{CM} = -0.3\text{V}$ to $3.3\text{V}$
DC Open-Loop Gain (large signal)	$A_{OL}$	4	—	115	—	dB	$R_L = 50\ \text{k}\Omega$ , $V_{OUT} = 0.3\text{V}$ to $V_{REG} - 0.3\text{V}$
Maximum Output Voltage Swing	$V_{OL}$ , $V_{OH}$	4	$V_{SS} + 10$	—	$V_{REG} - 10$	mV	$R_L = 50\ \text{k}\Omega$ , 0.5V input overdrive
Output Short Circuit Current	$I_{SC}$	4	—	20	—	mA	$V_{REG} = 3.3\text{V}$

- Note 1:** Wherever a specific  $V_{BST}$  value is listed under test conditions, the  $V_{BST}$  is forced externally with the inductor disconnected and the boost regulator is NOT running.
- Note 2:** Typical values are for design information only.
- Note 3:** The limits shown are 100% tested at  $25^{\circ}\text{C}$  only. Test limits are guard-banded based on temperature characterization to warrant compliance at temperature extremes.
- Note 4:** The Standby Supply Current  $I_{DDSTBY1}$  specified above can be approximated as follows:

$$I_{DDSTBY1} = I_{DDQ} + I_{IND}$$

Where  $I_{DDQ}$  = average current into  $V_{DD}$  supply

$$I_{IND} = \text{average inductor current} = V_{BST} * I_{VOQ} / (V_{IN} * \text{Efficiency})$$

$$V_{IN} = V_{DD} = 3\text{V}$$

## AC ELECTRICAL CHARACTERISTICS

Unless otherwise indicated, all parameters apply at  $T_A = -10^{\circ}\text{C}$  to  $+60^{\circ}\text{C}$ ,  $V_{DD} = 3\text{V}$ ,  $V_{SS} = 0\text{V}$ ,  $C_{REG} = 10\ \mu\text{F}$ ,  $C_{VBST} = 10\ \mu\text{F}$ .

Parameter	Symbol	Test Pin	Min.	Typ.	Max.	Units	Conditions
<b>OP Amp AC Response</b>							
Gain Bandwidth Product	GBWP	4	—	10	—	kHz	
Slew Rate	SR	4	—	3	—	V/ms	
Phase margin	PM	4	—	65	—	°	G = +1V/V
<b>Op Amp Noise</b>							
Input Voltage Noise	$E_{ni}$	1, 2	—	5	—	$\mu\text{V}_{\text{P-P}}$	f = 0.1 Hz to 10 kHz
Input Voltage Noise Density	$e_{ni}$	1, 2	—	170	—	nV/ $\sqrt{\text{Hz}}$	f = 1 kHz
Input Current Noise Density	$i_{ni}$	1, 2	—	0.6	—	fA/ $\sqrt{\text{Hz}}$	f = 1 kHz

- Note** 1: Wherever a specific  $V_{BST}$  value is listed under test conditions, the  $V_{BST}$  is forced externally with the inductor disconnected and the boost regulator is NOT running.
- 2: Typical values are for design information only.
- 3: The limits shown are 100% tested at  $25^{\circ}\text{C}$  only. Test limits are guard-banded based on temperature characterization to warrant compliance at temperature extremes.

## TEMPERATURE CHARACTERISTICS

**Electrical Characteristics:** Unless otherwise indicated,  $V_{DD} = 3\text{V}$ ,  $V_{SS} = 0\text{V}$

Parameter	Sym.	Min.	Typ.	Max.	Units	Conditions
<b>Temperature Ranges</b>						
Operating Temperature Range	$T_A$	-10	—	60	$^{\circ}\text{C}$	
Storage Temperature Range	$T_{STG}$	-55	—	125	$^{\circ}\text{C}$	
<b>Thermal Package Resistances</b>						
Thermal Resistance, 20L-SSOP	$\theta_{JA}$	—	87.3	—	$^{\circ}\text{C/W}$	

# RE46C800

## 2.0 PIN DESCRIPTIONS

The descriptions of the pins are listed in [Table 2-1](#).

**TABLE 2-1: PIN FUNCTION TABLE**

RE46C800	Symbol	Description
SSOP		
1	INP	Noninverting input of the op amp.
2	INN	Inverting input of the op amp.
3	V <sub>REF</sub>	Voltage reference for CO biasing and detection circuitry.
4	OPOUT	Output of the op amp.
5	9VDET	Logic input used to disable the boost regulator.
6	V <sub>DD</sub>	Low-voltage supply input.
7	ACDET	AC power detect pin.
8	LEDEN	Logic input used to enable the LED driver. Input is designed to interface with circuitry supplied by V <sub>REG</sub> , so input voltage levels will scale with the V <sub>REG</sub> voltage.
9	IO1	Logic bidirectional pin used for connection to remote units. This pin has an internal pull-down device. If used as an output, high level is VVO1.
10	IO2	Bidirectional pin used to send and receive IO1 interconnect signal status.
11	IODIR	Logic input used to select IO direction.
12	V <sub>REG</sub>	Regulated output voltage. Nominal output is 3.3V.
13	V <sub>BST</sub>	Boost regulator output, typically output voltage is 4V or 9.8V. Also used as the high-voltage supply input.
14	LEDPWR	Open drain NMOS output used to drive a visible LED.
15	LX	Open drain NMOS output used to drive the boost regulator inductor. The inductor should be connected from this pin to the positive supply through a low resistance path.
16	V <sub>SS</sub>	Connect to the negative supply voltage.
17	FEED	Usually connected to the feedback electrode of the piezoelectric horn through a current limiting resistor. If not used, this pin must be connected to V <sub>SS</sub> .
18	HS	HS is a complementary output to HB and connects to the ceramic electrode (S) of the piezoelectric transducer.
19	HB	This pin is connected to the metal electrode (B) of a piezoelectric transducer.
20	HRNEN	Logic input for horn enable designed to interface with circuitry supplied by V <sub>REG</sub> . Input voltage levels will scale with the V <sub>REG</sub> voltage.



## 3.0 DEVICE DESCRIPTION

### 3.1 Introduction

The RE46C800 provides the necessary analog functions to build a microcontroller-based CO or toxic gas detector. This includes an op amp and voltage reference for the electrochemical sensor, a voltage regulator for the microcontroller, an LED driver, a horn driver, a detector interconnect function, a boost regulator for 3V operation, and a power management system that allows operation from 3V, 9V or AC derived power. The power management system provides the capability for AC power with battery backup. The RE46C800 provides a simple means for the microcontroller to control the operation of the CO detector and provide the necessary signaling functions during an alarm condition.

### 3.2 CO Sensor Circuit

The RE46C800 provides a low offset op amp and reference voltage,  $V_{REF}$ , for a two terminal electrochemical CO or toxic gas sensor. The unity gain stable op amp provides rail-to-rail inputs and output. The op amp output is monitored by the microcontroller to determine the CO concentration. This uncommitted op amp can be used for other purposes such as temperature sensing.

### 3.3 Power Management System

The power management system allows the RE46C800 to be powered from a 3V or 9V battery or AC power. AC power is supplied as a DC voltage derived from an AC power supply. This DC voltage is diode connected to the  $V_{BST}$  pin of the RE46C800. AC supplied power and a 9V battery can both be diode connected to the  $V_{BST}$  pin.

For low-voltage systems the battery is connected to the  $V_{DD}$  pin. When only a low-voltage battery is available, the internal circuitry is powered from  $V_{DD}$ . When a 9V battery or AC power is available, the internal circuitry is powered from  $V_{REG}$ , which is a regulated 3.3V. The selection of the power source for the internal circuitry is controlled with the ACDET pin when the 9VDET pin is low.

In low-voltage systems that are also AC powered, the boost regulator will turn on if voltage of the AC supplied power drops below the specified boost regulator voltage. This can cause the low-voltage battery to discharge more rapidly than expected.

The 9VDET pin will disable the boost regulator if 9VDET is high. For a low-voltage system, the 9VDET pin should be connected to  $V_{SS}$  which will enable the boost regulator.

Table 3-1 shows the truth table for the power management system.

**TABLE 3-1: POWER MANAGEMENT SYSTEM**

9VDET	ACDET	Internal Supply	Boost Regulator
0	0	$V_{DD}$	Enabled
0	1	$V_{REG}$	Enabled
1	0	$V_{REG}$	Disabled
1	1	$V_{REG}$	Disabled

### 3.4 Boost Regulator

The boost regulator only operates in low-voltage applications. The boost regulator is a fixed off time boost regulator with peak current limiting. In low-boost operation the peak current is nominally 0.6A. In high-boost operation the peak current is nominally 1.2A. The boost regulator normally operates in Low-Boost mode, which provides a nominal 4V output voltage on the  $V_{BST}$  pin. In High-Boost mode, the boost regulator provides a nominal 9.8V on the  $V_{BST}$  pin. The boost regulator can be placed in High-Boost mode with HORNEN, LEDEN, or IODIR and IO2 both asserted high.

The brown-out threshold voltage is the  $V_{BST}$  voltage at which the voltage regulator and the horn will be disabled. When the  $V_{BST}$  voltage falls below the brown-out threshold voltage of 3.6V,  $V_{REG}$  will be disabled and pulled to  $V_{SS}$  with a nominal 40 mA current. When the boost voltage rises above the brown-out threshold voltage,  $V_{REG}$  is enabled.

### 3.5 Voltage Regulator

The voltage regulator provides a nominal 3.3V output at the  $V_{REG}$  pin and is intended to power a microcontroller. In normal operation, the regulator will source current up to 20 mA, but the current sinking capability is typically under 1  $\mu$ A. The voltage regulator is powered from the  $V_{BST}$  pin. In low-voltage applications the regulator is powered by the boost regulator and the regulator load current is part of the boost regulator load current. An overvoltage clamp is intended to limit the voltage at  $V_{REG}$  if it is pulled up by an external source to greater than 4V. When the boost regulator experiences a brown-out condition, the voltage regulator will be disabled and the  $V_{REG}$  output will be pulled to  $V_{SS}$ .

## 3.6 LED Driver

The LED drive circuit provides power to an LED, which can be used as a visual indicator by the system. The LED drive circuit can also be used as part of a battery check function in battery-powered applications. When LEDEN is asserted high the LED will load the  $V_{BST}$  output and the microcontroller can monitor the battery operation under load. In low-voltage systems the boost regulator will be placed into high-boost operation when LEDEN is asserted high. The load current is set by the resistor in series with the LED.

## 3.7 Interconnect Operation

The IO circuitry provides the means for the CO detector to be connected to other CO detectors or smoke alarms. Table 3-2 below provides the truth table for the interconnect circuit operation. IO1 is a bidirectional pin that connects to other CO detectors or smoke alarms. IO2 is a bidirectional pin that connects to the microcontroller. IODIR connects to the microcontroller and determines when IO1 and IO2 act as an input or output. When IO1 is used as an output asserting a logic high, the IO1 output acts as current source that is biased from  $V_{BST}$ . In low-voltage applications where the boost regulator is enabled, the boost regulator will operate in High-Boost mode. When IO1 is used as an output asserting a logic low, the IO1 output acts as current sink. IO2 logic levels are referenced to  $V_{REG}$ .

**TABLE 3-2: INTERCONNECT LOGIC TRUTH TABLE**

IODIR	IO2		IO1	
	Input	Output	Input	Output
1	0	—	—	0
1	1	—	—	1
0	—	0	0	—
0	—	1	1	—

## 4.0 APPLICATION NOTES

### 4.1 Boost Regulator

The boost regulator in High-Boost mode (nominal  $V_{BST} = 9.8V$ ) can draw current pulses of greater than 1A and is, therefore, very sensitive to series resistance. Critical components of this resistance are: the inductor DC resistance, the internal resistance of the battery and the resistance in the connections from the inductor to the battery, from the inductor to the LX pin, from the inductor through the boost capacitor, and from the  $V_{SS}$  pin to the battery. In order to function properly under full load at  $V_{DD} = 2V$ , the total of the inductor and interconnect resistances should not exceed  $0.3\Omega$ . The internal battery resistance should be no more than  $0.5\Omega$  and a low ESR capacitor of  $10\mu F$  or more should be connected in parallel with the battery to average the current draw over the boost regulator switching cycle. The Schottky diode and inductor should be specified with a maximum operating current of 1.5A or higher. The boost capacitor should have a low ESR.

### 4.2 Typical Applications

A few typical applications using the RE46C800 are listed below:

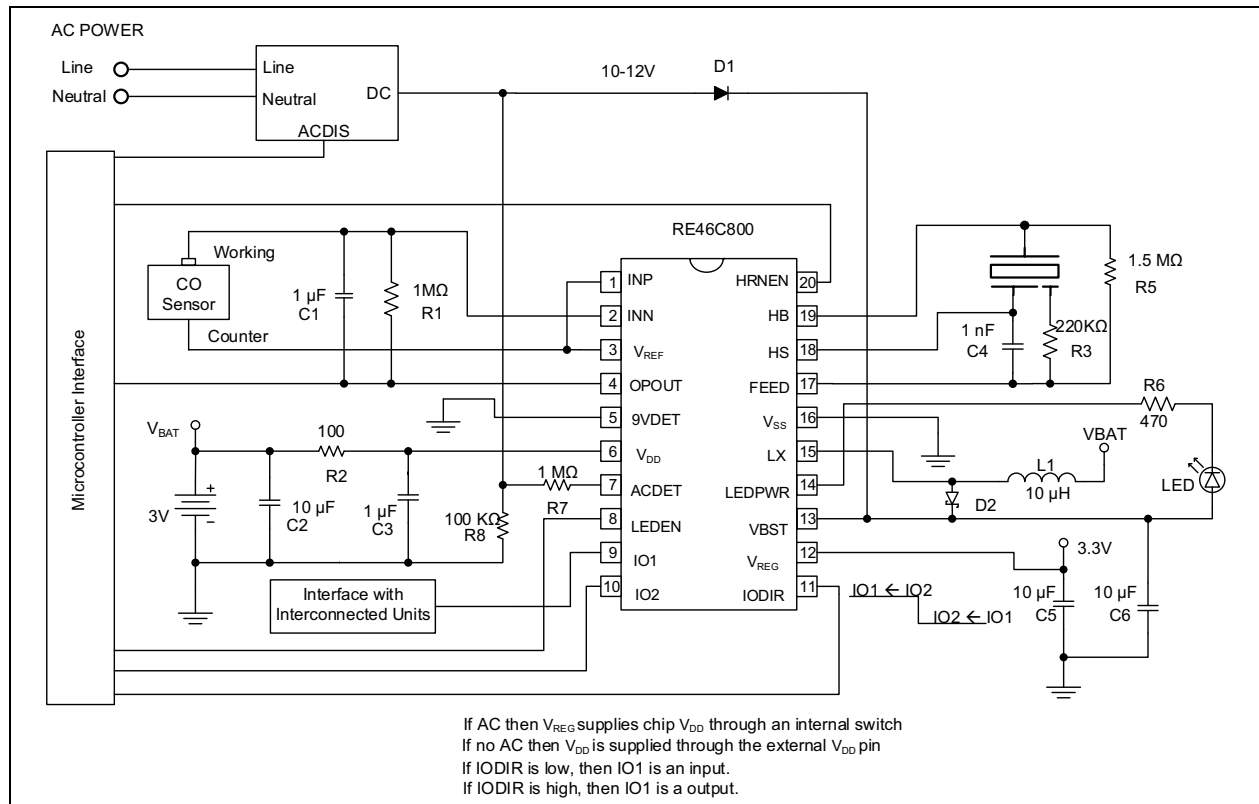

**FIGURE 4-1:** Typical Application: AC with 3V Battery Backup.





# RE46C800

---

NOTES:

## 5.0 PACKAGING INFORMATION

### 5.1 Package Marking Information

20-Lead SSOP (5.30 mm)

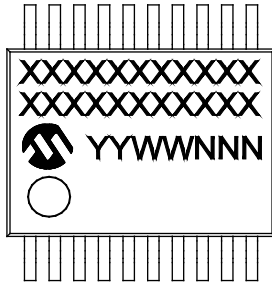

Example

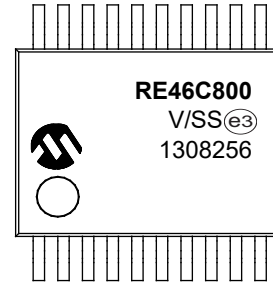

<b>Legend:</b>	XX...X	Customer-specific information
	Y	Year code (last digit of calendar year)
	YY	Year code (last 2 digits of calendar year)
	WW	Week code (week of January 1 is week '01')
	NNN	Alphanumeric traceability code
	(e3)	Pb-free JEDEC designator for Matte Tin (Sn)
	*	This package is Pb-free. The Pb-free JEDEC designator (e3) can be found on the outer packaging for this package.

**Note:** In the event the full Microchip part number cannot be marked on one line, it will be carried over to the next line, thus limiting the number of available characters for customer-specific information.

# RE46C800

## 20-Lead Plastic Shrink Small Outline (SS) – 5.30 mm Body [SSOP]

**Note:** For the most current package drawings, please see the Microchip Packaging Specification located at <http://www.microchip.com/packaging>

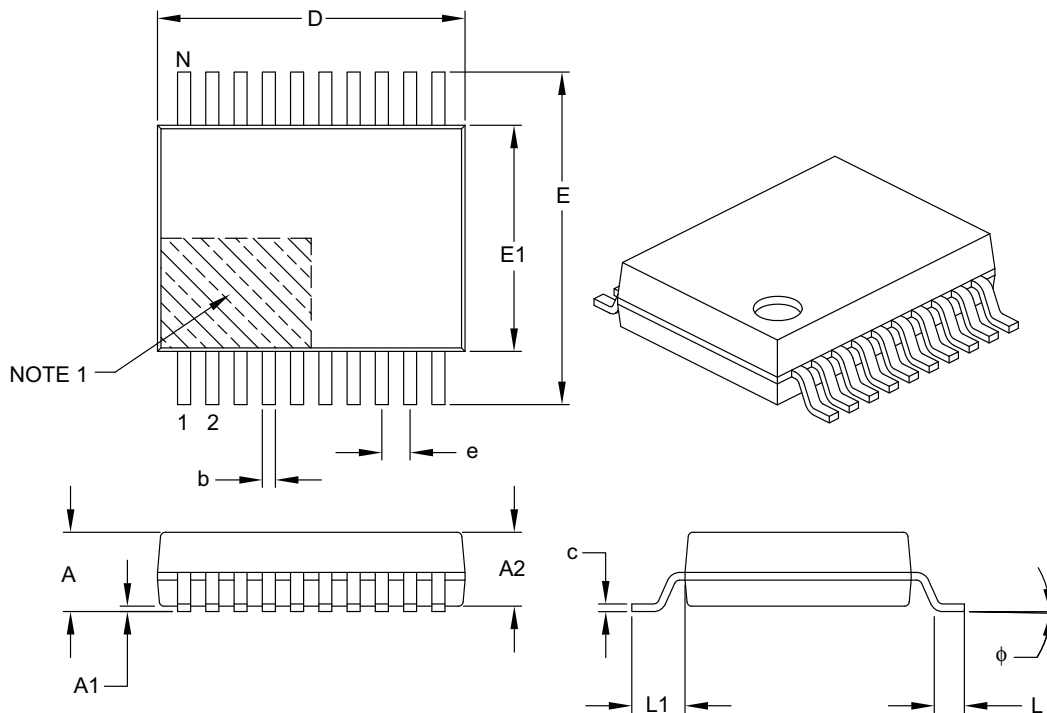

		Units	MILLIMETERS		
Dimension Limits			MIN	NOM	MAX
Number of Pins	N		20		
Pitch	e		0.65 BSC		
Overall Height	A	–	–	–	2.00
Molded Package Thickness	A2		1.65	1.75	1.85
Standoff	A1		0.05	–	–
Overall Width	E		7.40	7.80	8.20
Molded Package Width	E1		5.00	5.30	5.60
Overall Length	D		6.90	7.20	7.50
Foot Length	L		0.55	0.75	0.95
Footprint	L1		1.25 REF		
Lead Thickness	c		0.09	–	0.25
Foot Angle	φ		0°	4°	8°
Lead Width	b		0.22	–	0.38

**Notes:**

- Pin 1 visual index feature may vary, but must be located within the hatched area.
- Dimensions D and E1 do not include mold flash or protrusions. Mold flash or protrusions shall not exceed 0.20 mm per side.
- Dimensioning and tolerancing per ASME Y14.5M.

BSC: Basic Dimension. Theoretically exact value shown without tolerances.

REF: Reference Dimension, usually without tolerance, for information purposes only.

Microchip Technology Drawing C04-072B



## 20-Lead Plastic Shrink Small Outline (SS) - 5.30 mm Body [SSOP]

**Note:** For the most current package drawings, please see the Microchip Packaging Specification located at <http://www.microchip.com/packaging>

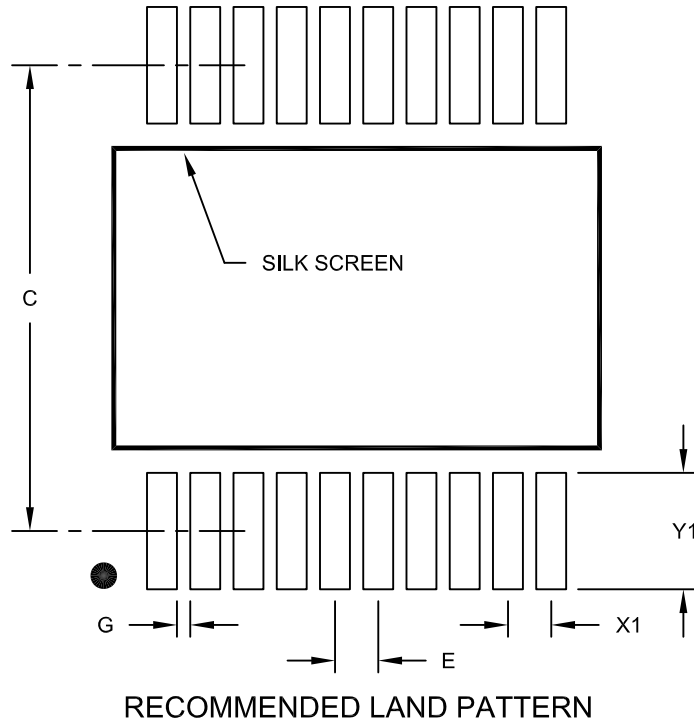

Dimension Limits	Units	MILLIMETERS		
		MIN	NOM	MAX
Contact Pitch	E	0.65 BSC		
Contact Pad Spacing	C		7.20	
Contact Pad Width (X20)	X1			0.45
Contact Pad Length (X20)	Y1			1.75
Distance Between Pads	G	0.20		

**Notes:**

1. Dimensioning and tolerancing per ASME Y14.5M

BSC: Basic Dimension. Theoretically exact value shown without tolerances.

Microchip Technology Drawing No. C04-2072A

# RE46C800

---

NOTES:

## APPENDIX A: REVISION HISTORY

### Revision C (October 2017)

The following is the list of modifications:

- Updated [Figure 4-2](#)
- Various typographical edits

### Revision B (July 2013)

The following is the list of modifications.

- Removed the lead free designation in part ordering number in the [Product Identification System](#) section.

### Revision A (March 2013)

- Initial Release of this Document.

# RE46C800

---

NOTES:

## PRODUCT IDENTIFICATION SYSTEM

To order or obtain information, e.g., on pricing or delivery, refer to the factory or the listed sales office.

<u>PART NO.</u>	X	X
Device	Package	Number of Pins
<b>Device:</b>	RE46C800	CMOS Carbon Monoxide Detector IC
	RE46C318T	CMOS Carbon Monoxide Detector IC (Tape and Reel)
<b>Package:</b>	SS20 = Plastic Shrink Small Outline - Narrow, 5.33 mm Body, 20-Lead (SSOP)	

**Examples:**

- a) RE46C800SS20: 20LD SSOP package
- b) RE46C800SS20T: 20LD SSOP package  
Tape and Reel

# RE46C800

---

NOTES:

---

---

**Note the following details of the code protection feature on Microchip devices:**

- Microchip products meet the specification contained in their particular Microchip Data Sheet.
- Microchip believes that its family of products is one of the most secure families of its kind on the market today, when used in the intended manner and under normal conditions.
- There are dishonest and possibly illegal methods used to breach the code protection feature. All of these methods, to our knowledge, require using the Microchip products in a manner outside the operating specifications contained in Microchip's Data Sheets. Most likely, the person doing so is engaged in theft of intellectual property.
- Microchip is willing to work with the customer who is concerned about the integrity of their code.
- Neither Microchip nor any other semiconductor manufacturer can guarantee the security of their code. Code protection does not mean that we are guaranteeing the product as "unbreakable."

Code protection is constantly evolving. We at Microchip are committed to continuously improving the code protection features of our products. Attempts to break Microchip's code protection feature may be a violation of the Digital Millennium Copyright Act. If such acts allow unauthorized access to your software or other copyrighted work, you may have a right to sue for relief under that Act.

---

Information contained in this publication regarding device applications and the like is provided only for your convenience and may be superseded by updates. It is your responsibility to ensure that your application meets with your specifications. MICROCHIP MAKES NO REPRESENTATIONS OR WARRANTIES OF ANY KIND WHETHER EXPRESS OR IMPLIED, WRITTEN OR ORAL, STATUTORY OR OTHERWISE, RELATED TO THE INFORMATION, INCLUDING BUT NOT LIMITED TO ITS CONDITION, QUALITY, PERFORMANCE, MERCHANTABILITY OR FITNESS FOR PURPOSE. Microchip disclaims all liability arising from this information and its use. Use of Microchip devices in life support and/or safety applications is entirely at the buyer's risk, and the buyer agrees to defend, indemnify and hold harmless Microchip from any and all damages, claims, suits, or expenses resulting from such use. No licenses are conveyed, implicitly or otherwise, under any Microchip intellectual property rights unless otherwise stated.

*Microchip received ISO/TS-16949:2009 certification for its worldwide headquarters, design and wafer fabrication facilities in Chandler and Tempe, Arizona; Gresham, Oregon and design centers in California and India. The Company's quality system processes and procedures are for its PIC® MCUs and dsPIC® DSCs, KEELoQ® code hopping devices, Serial EEPROMs, microperipherals, nonvolatile memory and analog products. In addition, Microchip's quality system for the design and manufacture of development systems is ISO 9001:2000 certified.*

**QUALITY MANAGEMENT SYSTEM  
CERTIFIED BY DNV  
= ISO/TS 16949 =**

### Trademarks

The Microchip name and logo, the Microchip logo, AnyRate, AVR, AVR logo, AVR Freaks, BeaconThings, BitCloud, CryptoMemory, CryptoRF, dsPIC, FlashFlex, flexPWR, Heldo, JukeBlox, KEELoQ, KEELoQ logo, Kleer, LANCheck, LINK MD, maXStylus, maXTouch, MediaLB, megaAVR, MOST, MOST logo, MPLAB, OptoLyzer, PIC, picoPower, PICSTART, PIC32 logo, Prochip Designer, QTouch, RightTouch, SAM-BA, SpyNIC, SST, SST Logo, SuperFlash, tinyAVR, UNI/O, and XMEGA are registered trademarks of Microchip Technology Incorporated in the U.S.A. and other countries.

ClockWorks, The Embedded Control Solutions Company, EtherSynch, Hyper Speed Control, HyperLight Load, IntelliMOS, mTouch, Precision Edge, and Quiet-Wire are registered trademarks of Microchip Technology Incorporated in the U.S.A.

Adjacent Key Suppression, AKS, Analog-for-the-Digital Age, Any Capacitor, AnyIn, AnyOut, BodyCom, chipKIT, chipKIT logo, CodeGuard, CryptoAuthentication, CryptoCompanion, CryptoController, dsPICDEM, dsPICDEM.net, Dynamic Average Matching, DAM, ECAN, EtherGREEN, In-Circuit Serial Programming, ICSP, Inter-Chip Connectivity, JitterBlocker, KleerNet, KleerNet logo, Mindi, MiWi, motorBench, MPASM, MPF, MPLAB Certified logo, MPLIB, MPLINK, MultiTRAK, NetDetach, Omniscient Code Generation, PICDEM, PICDEM.net, PICKit, PICtail, PureSilicon, QMatrix, RightTouch logo, REAL ICE, Ripple Blocker, SAM-ICE, Serial Quad I/O, SMART-I.S., SQI, SuperSwitcher, SuperSwitcher II, Total Endurance, TSHARC, USBCheck, VariSense, ViewSpan, WiperLock, Wireless DNA, and ZENA are trademarks of Microchip Technology Incorporated in the U.S.A. and other countries.

SQTP is a service mark of Microchip Technology Incorporated in the U.S.A.

Silicon Storage Technology is a registered trademark of Microchip Technology Inc. in other countries.

GestIC is a registered trademark of Microchip Technology Germany II GmbH & Co. KG, a subsidiary of Microchip Technology Inc., in other countries.

All other trademarks mentioned herein are property of their respective companies.

© 2013 - 2017, Microchip Technology Incorporated, All Rights Reserved.

ISBN: 978-1-5224-2302-7



# MICROCHIP

## Worldwide Sales and Service

### AMERICAS

**Corporate Office**  
2355 West Chandler Blvd.  
Chandler, AZ 85224-6199  
Tel: 480-792-7200  
Fax: 480-792-7277  
Technical Support:  
<http://www.microchip.com/support>  
Web Address:  
[www.microchip.com](http://www.microchip.com)

**Atlanta**  
Duluth, GA  
Tel: 678-957-9614  
Fax: 678-957-1455

**Austin, TX**  
Tel: 512-257-3370

**Boston**  
Westborough, MA  
Tel: 774-760-0087  
Fax: 774-760-0088

**Chicago**  
Itasca, IL  
Tel: 630-285-0071  
Fax: 630-285-0075

**Dallas**  
Addison, TX  
Tel: 972-818-7423  
Fax: 972-818-2924

**Detroit**  
Novi, MI  
Tel: 248-848-4000

**Houston, TX**  
Tel: 281-894-5983

**Indianapolis**  
Noblesville, IN  
Tel: 317-773-8323  
Fax: 317-773-5453  
Tel: 317-536-2380

**Los Angeles**  
Mission Viejo, CA  
Tel: 949-462-9523  
Fax: 949-462-9608  
Tel: 951-273-7800

**Raleigh, NC**  
Tel: 919-844-7510

**New York, NY**  
Tel: 631-435-6000

**San Jose, CA**  
Tel: 408-735-9110  
Tel: 408-436-4270

**Canada - Toronto**  
Tel: 905-695-1980  
Fax: 905-695-2078

### ASIA/PACIFIC

**Asia Pacific Office**  
Suites 3707-14, 37th Floor  
Tower 6, The Gateway  
Harbour City, Kowloon

**Hong Kong**  
Tel: 852-2943-5100  
Fax: 852-2401-3431

**Australia - Sydney**  
Tel: 61-2-9868-6733  
Fax: 61-2-9868-6755

**China - Beijing**  
Tel: 86-10-8569-7000  
Fax: 86-10-8528-2104

**China - Chengdu**  
Tel: 86-28-8665-5511  
Fax: 86-28-8665-7889

**China - Chongqing**  
Tel: 86-23-8980-9588  
Fax: 86-23-8980-9500

**China - Dongguan**  
Tel: 86-769-8702-9880

**China - Guangzhou**  
Tel: 86-20-8755-8029

**China - Hangzhou**  
Tel: 86-571-8792-8115  
Fax: 86-571-8792-8116

**China - Hong Kong SAR**  
Tel: 852-2943-5100  
Fax: 852-2401-3431

**China - Nanjing**  
Tel: 86-25-8473-2460  
Fax: 86-25-8473-2470

**China - Qingdao**  
Tel: 86-532-8502-7355  
Fax: 86-532-8502-7205

**China - Shanghai**  
Tel: 86-21-3326-8000  
Fax: 86-21-3326-8021

**China - Shenyang**  
Tel: 86-24-2334-2829  
Fax: 86-24-2334-2393

**China - Shenzhen**  
Tel: 86-755-8864-2200  
Fax: 86-755-8203-1760

**China - Wuhan**  
Tel: 86-27-5980-5300  
Fax: 86-27-5980-5118

**China - Xian**  
Tel: 86-29-8833-7252  
Fax: 86-29-8833-7256

### ASIA/PACIFIC

**China - Xiamen**  
Tel: 86-592-2388138  
Fax: 86-592-2388130

**China - Zhuhai**  
Tel: 86-756-3210040  
Fax: 86-756-3210049

**India - Bangalore**  
Tel: 91-80-3090-4444  
Fax: 91-80-3090-4123

**India - New Delhi**  
Tel: 91-11-4160-8631  
Fax: 91-11-4160-8632

**India - Pune**  
Tel: 91-20-3019-1500

**Japan - Osaka**  
Tel: 81-6-6152-7160  
Fax: 81-6-6152-9310

**Japan - Tokyo**  
Tel: 81-3-6880-3770  
Fax: 81-3-6880-3771

**Korea - Daegu**  
Tel: 82-53-744-4301  
Fax: 82-53-744-4302

**Korea - Seoul**  
Tel: 82-2-554-7200  
Fax: 82-2-558-5932 or  
82-2-558-5934

**Malaysia - Kuala Lumpur**  
Tel: 60-3-6201-9857  
Fax: 60-3-6201-9859

**Malaysia - Penang**  
Tel: 60-4-227-8870  
Fax: 60-4-227-4068

**Philippines - Manila**  
Tel: 63-2-634-9065  
Fax: 63-2-634-9069

**Singapore**  
Tel: 65-6334-8870  
Fax: 65-6334-8850

**Taiwan - Hsin Chu**  
Tel: 886-3-5778-366  
Fax: 886-3-5770-955

**Taiwan - Kaohsiung**  
Tel: 886-7-213-7830

**Taiwan - Taipei**  
Tel: 886-2-2508-8600  
Fax: 886-2-2508-0102

**Thailand - Bangkok**  
Tel: 66-2-694-1351  
Fax: 66-2-694-1350

### EUROPE

**Austria - Wels**  
Tel: 43-7242-2244-39  
Fax: 43-7242-2244-393

**Denmark - Copenhagen**  
Tel: 45-4450-2828  
Fax: 45-4485-2829

**Finland - Espoo**  
Tel: 358-9-4520-820

**France - Paris**  
Tel: 33-1-69-53-63-20  
Fax: 33-1-69-30-90-79

**Germany - Garching**  
Tel: 49-8931-9700

**Germany - Haan**  
Tel: 49-2129-3766400

**Germany - Heilbronn**  
Tel: 49-7131-67-3636

**Germany - Karlsruhe**  
Tel: 49-721-625370

**Germany - Munich**  
Tel: 49-89-627-144-0  
Fax: 49-89-627-144-44

**Germany - Rosenheim**  
Tel: 49-8031-354-560

**Israel - Ra'anana**  
Tel: 972-9-744-7705

**Italy - Milan**  
Tel: 39-0331-742611  
Fax: 39-0331-466781

**Italy - Padova**  
Tel: 39-049-7625286

**Netherlands - Drunen**  
Tel: 31-416-690399  
Fax: 31-416-690340

**Norway - Trondheim**  
Tel: 47-7289-7561

**Poland - Warsaw**  
Tel: 48-22-3325737

**Romania - Bucharest**  
Tel: 40-21-407-87-50

**Spain - Madrid**  
Tel: 34-91-708-08-90  
Fax: 34-91-708-08-91

**Sweden - Gothenberg**  
Tel: 46-31-704-60-40

**Sweden - Stockholm**  
Tel: 46-8-5090-4654

**UK - Wokingham**  
Tel: 44-118-921-5800  
Fax: 44-118-921-5820



# Mouser Electronics

Authorized Distributor

Click to View Pricing, Inventory, Delivery & Lifecycle Information:

[Microchip:](#)

[RE46C800SS20T](#) [RE46C800SS20](#)

Компания «Life Electronics» занимается поставками электронных компонентов импортного и отечественного производства от производителей и со складов крупных дистрибьюторов Европы, Америки и Азии.

С конца 2013 года компания активно расширяет линейку поставок компонентов по направлению коаксиальный кабель, кварцевые генераторы и конденсаторы (керамические, пленочные, электролитические), за счёт заключения дистрибьюторских договоров

Мы предлагаем:

- Конкурентоспособные цены и скидки постоянным клиентам.
- Специальные условия для постоянных клиентов.
- Подбор аналогов.
- Поставку компонентов в любых объемах, удовлетворяющих вашим потребностям.
- Приемлемые сроки поставки, возможна ускоренная поставка.
- Доставку товара в любую точку России и стран СНГ.
- Комплексную поставку.
- Работу по проектам и поставку образцов.
- Формирование склада под заказчика.
- Сертификаты соответствия на поставляемую продукцию (по желанию клиента).
- Тестирование поставляемой продукции.
- Поставку компонентов, требующих военную и космическую приемку.
- Входной контроль качества.
- Наличие сертификата ISO.

В составе нашей компании организован Конструкторский отдел, призванный помогать разработчикам, и инженерам.

Конструкторский отдел помогает осуществить:

- Регистрацию проекта у производителя компонентов.
- Техническую поддержку проекта.
- Защиту от снятия компонента с производства.
- Оценку стоимости проекта по компонентам.
- Изготовление тестовой платы монтаж и пусконаладочные работы.



Тел: +7 (812) 336 43 04 (многоканальный)

Email: [org@lifeelectronics.ru](mailto:org@lifeelectronics.ru)