

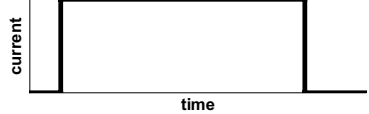
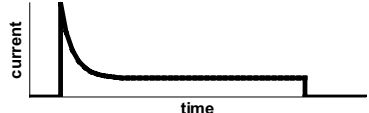

Automotive Applications

Typical Automotive Applications

Load	Application examples	Typical current curve
Resistive Loads	- Heatings (rear window heating, seat heating glow plug, air/water preheating)	
Capacitive Loads	- Lamps (front and rear beam, fog lights, flasher) - Filter capacitors in electronic modules (engine management module, ABS module)	
Inductive Loads	- Solenoids (vales, clutches, relay coils) - Motors and pumps (power window, central lock, cooling fan)	

Introduction

The range of applications can be classified into resistive loads, capacitive loads and inductive loads. The current curve of resistive loads is specified by the load voltage and load resistance. Capacitive loads have a high inrush current and a low steady current. Therefore lamps are counted to the capacitive loads, because the cold filament has a significantly lower resistance, than the hot filament. Inductive loads are characterized by an exponential current increase and a remarkable switch off arc, induced by the demagnetization of the magnetic circuit of the load. Power supply relays (clamp relays) can switch or feed a mixture of different loads.

The circuit design of resistive and capacitive loads is usually a simple switch on and switch off. Motor load circuits are often more complex. The most typical circuits are described hereafter.

Short-Circuit Brake

The short-circuit brake is used, wherever an electric motor must be braked (e.g. wiper). The short-circuit brake transforms the rotational energy of the motor into electrical energy. The short-circuit brake can be critical at higher load voltages. If the switch-off arc does not extinguish during the transition time of the movable contact, the arc creates a direct shortage of the power source. Particularly in 24VDC systems, the resulting extremely high arc current could cause almost instantly severe damage to the contacts and could destroy the entire relay.

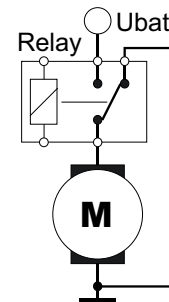

Fig. 1 Short-circuit brake

Motor-Reverse Circuit (H-Bridge)

The H-bridge is used to operate a motor in two directions (e.g. door lock, steering lock, power window, seat adjustment, etc.). The operation time is typically very short compared to the thermal time constant of the relay (e.g. door lock <1s, power window <10s). This means, H-bridge relays must be designed for high current-switching-capability, but not for high current-carrying-capability. Higher load voltages can be critical, due to possible short-circuit-arcs (see also short-circuit brake).

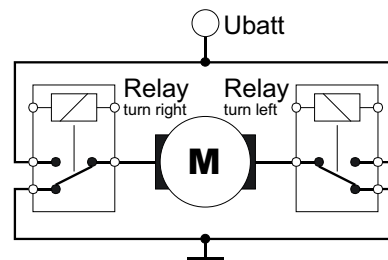

Fig. 2 H-bridge

Automotive Applications

Wiper Circuits

To stop the wiper in the correct position, a short-circuit brake is used. This can be done either by an internal slipping (usually used for rear wiper) or with the normally closed contact of the relay (usually used for front wiper). This requires a high switching capability of the N/C-contact, especially in combination with intermittent wipe function or rain sensor control. Dual speed wipers have two windings, which are commuted by a second relay. There are also wiper systems without mechanical gear, which are electrically reversed with a H-bridge circuit.

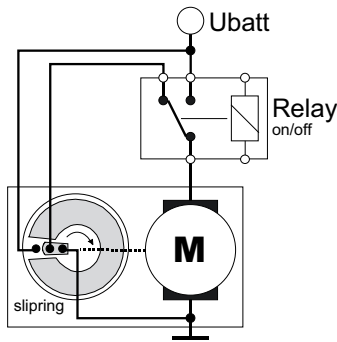

Fig. 3 Wiper with slipping

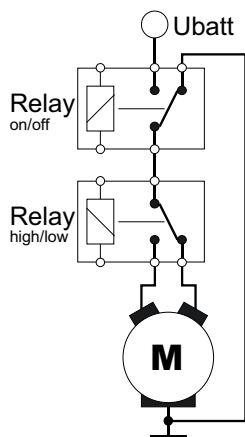

Fig. 4 Dual speed wiper-circuit

Cooling Fan Circuits

Depending on the size of the engine, either one or two fans are used to cool the engine. There are different possibilities to control the speed of the fans. Single fan systems are usually controlled by one or more serial resistors. The disadvantage is the electrical power loss of the resistors. Double fan systems are normally controlled by switching them either in series (low speed) or in parallel (high speed). If more speed steps are needed, additional serial resistors are used. A more sophisticated method is a PWM-controlled brushless motor. In commercial vehicles the cooling fan is mostly driven directly by the motor shaft.

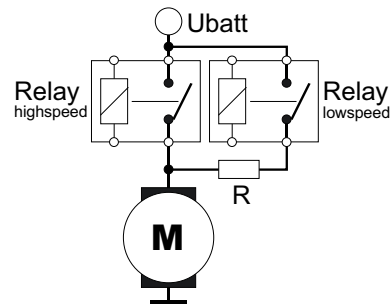

Fig. 5 Single fan circuit

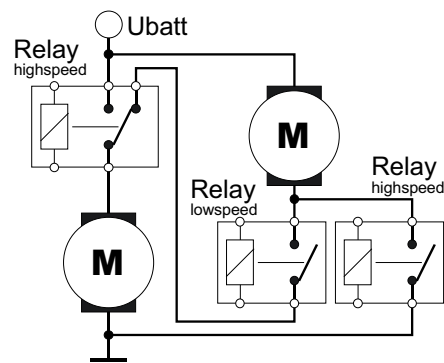

Fig. 6 Double fan circuit

Automotive Applications

Coil Suppression Circuits

The disconnection of the relay coil generates a transient voltage peak, which is only limited by the parasitic inductivity and capacity of the electrical system. In most of the cases it is necessary to suppress the transient voltage peak to typically 60VDC – 100VDC for the protection of the relay driver or the vehicle electrical system. Any voltage suppression of the relay coil influences the dynamics of the electromechanical system and can reduce the lifetime.

The best protection method for the driver is a diode in parallel to the relay coil. But this method has the worst influence on lifetime of the relay. Typical suppression methods are a resistor in parallel to the coil (preferably as internal component in plug-in relays) or a Zener diode in parallel to the relay driver (preferably for PCB relays).

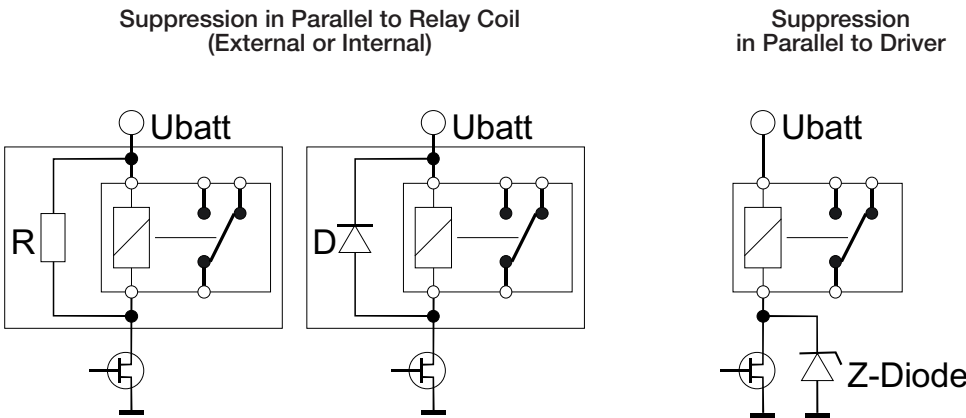

Fig. 7 Coil suppression circuits

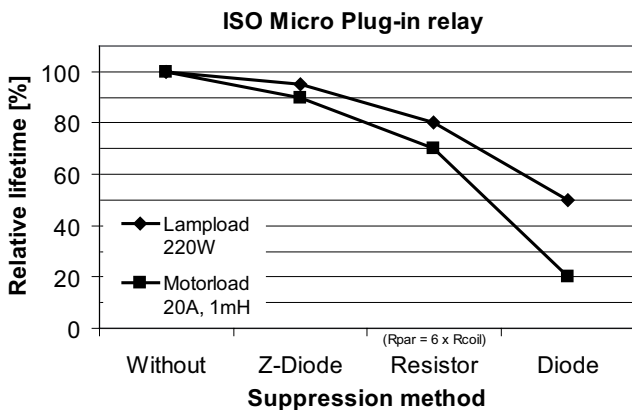

Fig. 8 Influence of coil suppression on the lifetime

Diagnostics of Relays

Introduction

With the increase of electronic circuits and safety requirements in cars, more and more switching contacts are monitored by diagnostic routines. Similar routines are used by the system suppliers before, during and after the assembly processes (In-Circuit and End-Of-Line tests) as well.

Automotive relays are originally designed to switch real automotive applications (e.g. motors, lights, heating, etc.) with a load voltage of 12VDC (or 24VDC or 42VDC) and load currents above 1A. Lower diagnostic current and voltage levels can result in wrong interpretations of the state of the relay contact.

This paper explains the technical background of the relay contact system, coil system and dynamic behavior and gives recommendations for applicable diagnostic routines.

Contact System

The most common contact materials for automotive relays are fine grain silver ($AgNi_{0.15}$) and silver tin oxide ($AgSnO_2$). Both materials are affected by sulfidation and oxidation. These layers of oxides, sulfides and other compounds will be formed on the surface of metal-contacts by absorption of gas molecules from the ambient atmosphere within a very short time. The layers will increase the contact resistance. The resistance of such layers depends on the thickness of the layer, effective contact area and the specific resistance of the contact material/layer. To get a reliable electric contact these layers have to be destroyed. This can be done by mechanical, electrical or thermal destruction. A mechanical destruction requires high contact forces. With the very high degree of miniaturization of automotive relays, those contact forces cannot be safely achieved, especially for normally-closed contacts. An electrical destruction requires a specific breakdown voltage and current. This destruction process is called A-fritting.

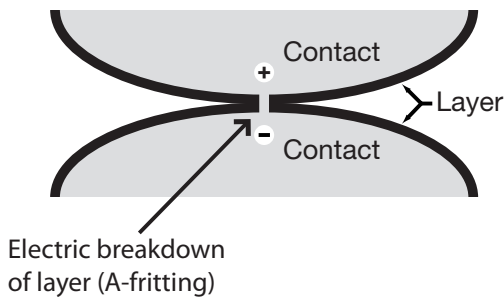

Fig. 1 Contact layers

The breakdown voltage depends on the thickness and specific resistance of the layer and can reach theoretically some hundred volts. In the practice of automotive relays the breakdown voltage can be up to 3VDC. A current of min. 10mA is needed to start the A-fritting. After the electrical breakdown a small current is forced through very thin channels in the layer. The resulting local high current density heats the conducting channels up quickly, destroying the layers, until finally (within a few ms) a metal to metal bridge is established. This process is called B-fritting. The B-fritting voltage depends again on the thickness and specific resistance of the layer and can reach in the practice of automotive relays up to 300mV.

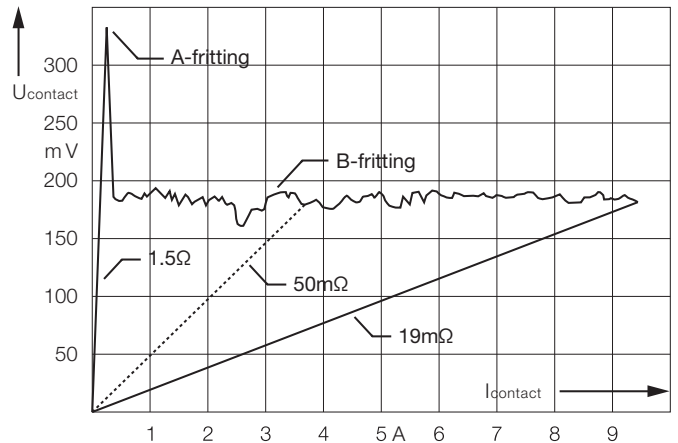

Fig. 2 Fritting of a relay contact

A thermal destruction requires high temperatures, which will only be generated by high contact currents or electric arcs (disconnecting inductive loads). The thermal destruction can only take place, after an electrical destruction.

Coil System and Dynamic Behavior

Automotive relay coils are designed for DC-voltages. The switching times (i.e. operate time or switch-on time and release time or switch-off time) are usually in the low millisecond-range. The operate time depends on the applied coil voltage. Fig. 3 shows the relation of the operate time and coil voltage, related to the actual pull-in voltage. The nominal voltage in the displayed case is 170% of the actual pull-in voltage at an ambient temperature of 23°C (e.g. 7VDC pull-in voltage at 12VDC nominal voltage). Higher coil temperatures increase the pull-in voltage and subsequently increase the operate time at the same applied coil voltage. Including possible contact bouncing, the operate time can be three times as high as the typical values shown in the datasheets.

Diagnostics of Relays

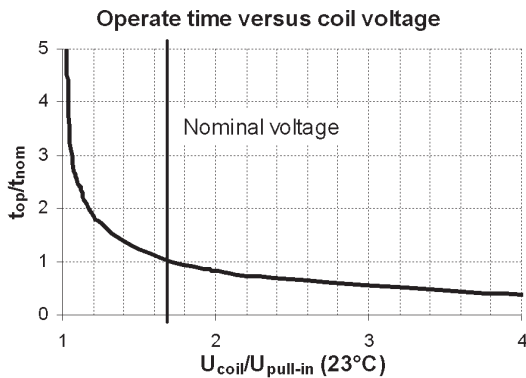

Fig. 3 Operate time

The release time depends mainly only on the used coil suppression. A low ohmic device (e.g. a diode) in parallel to the relay coil can increase the release time by a factor of up to 4 compared to the typical values shown in the datasheets.

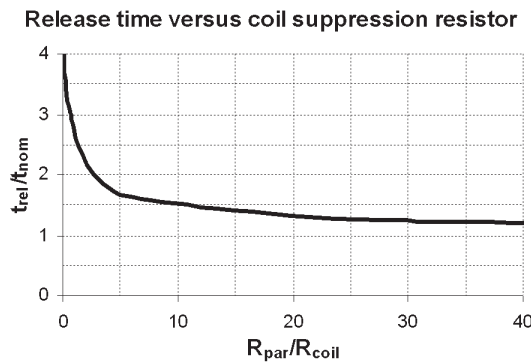

Fig. 4 Release time

Coil Resistance

The inductivity of automotive relay coils can exceed (in the unsaturated range) 1H. This results in time constants tau between 1 to 50ms for the exponential inductive current increase (jump response). If the ohmic coil resistance is measured with a 4-pole measurement, the resistance value will be wrong, if it is measured during the inductive current increase after switch on.

Remarks

1. During the lifetime of the car, the relay parameters can alter due to ageing processes like contact erosion, fretting corrosion and relaxation. Moreover the environmental requirements (temperature, vibration etc.) in the car are higher than in IC- or EOL-tests. Therefore we recommend for diagnostic routines in the car a higher threshold voltage (approx. 3VDC) and higher delay times (min. 15 times of the typical switching times).
2. Most of the applications, switched by relays, are not safety related. If a potential relay failure is detected, we recommend to not block any further activation of the relay but to write the occurrence into the error memory.

Recommendations for Diagnostic Routines

A contact diagnostic routine must:

Take into account, that the contact resistance may be non-linear. Due to the explained fritting phenomena, the contact resistance can be non-linear. This means, that the contact resistance, measured at low voltage and current levels (e.g. standard multimeter) can be significantly higher than the contact resistance under real conditions (e.g. supplying a 100W load). We recommend to perform the diagnostic routine with the real application and real board net voltage connected.

Supply a sufficient voltage and current to force the A-fritting. If the diagnostic routine cannot be performed with real application and voltage, the measurement voltage level must secure an electrical breakdown of possible layers. We recommend a voltage level of min. 5VDC and current of min. 100mA for min. 1ms.

Accept, that the voltage drop can be 300mV. The B-fritting is a physical phenomenon, which can occur on all silver based contacts. For signal-applications, special signal relays are available. We recommend to set the diagnostic threshold voltage to 500mV per relay contact (important for H-bridges or serial contact arrangements).

Regard the maximum possible switching times. If the status of the contact has to be changed for the diagnostic routine (energize or de-energize relay), the routine must wait until the intended contact status is reached. Depending on ambient conditions (temperature, voltage levels, coil circuits) the times can be significantly longer than the specified typical times. We recommend a delay time of min. 10 times of the typical switching times or min. 20ms after first contact status change at min. 110% pull-in voltage.

A coil diagnostic routine must:

Secure, that the status of the contact does not change during the diagnostic. If the coil driver is monitored by a watchdog routine, the energizing/de-energizing time of the coil must not result in an unintended closing or opening of the contacts. We recommend times of max. 0.5ms.

Pulse Width Modulation (PWM) and Relays

Introduction

Efficient energy management is one of the main goals in automotive industry. Regulating actuators by Pulse Width Modulation (PWM) is a widespread means of improving efficiency. There has been an increasing penetration of PWM controlled applications like heater blowers, lamps, EPAS. Once a PWM controller is available in the car it could be used for several applications.

Heat dissipation of monostable relay coils is one source of high temperatures in relay boxes, distribution and switching modules. That limits not only the relay performance, but the performance of the whole unit, too. These heat sources could be removed by using latching relays or at least be reduced by use of high resistive coils and / or by applying PWM controlled driver circuits. This application note summarizes key aspects, which have to be taken into account when using PWM strategy for the relay coil driver.

Relay Status

The best way to regulate the relay coil power consumption would be a DC current driver, since the main electrical parameters of a relay (pull-in, pull-through and holding currents) are to a certain extent temperature independent. But relay coils are usually voltage driven. Thus those characteristics translate into the temperature dependent voltages for pull-in, pull-through and holding. The reason is the temperature depending resistance of the coil wire material, i.e. copper.

Once the relay has pulled through, it keeps its status (armature keeps to its position on the core) unless the coil current falls below the holding current. For shock and vibration resistance there is an additional excess current required, which depends on the relay type, further relay parameters and shock and vibration requirements.

PWM controlled drivers regulate the effective applied voltage by changing the duty ratio of DC voltage normally at a given frequency. Inductive systems like relay coils respond in presence of parallel components to a negative going edge with a current decrease.

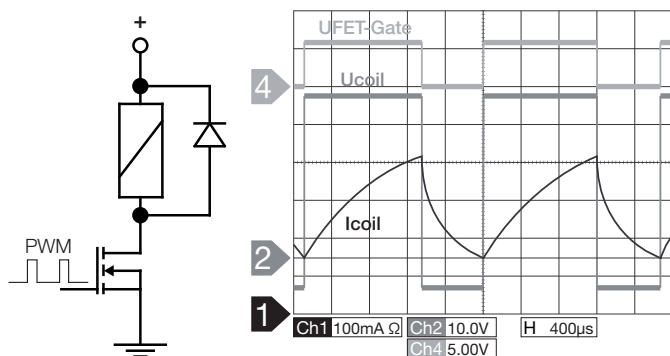

Figure 1: Current response to PWM voltage step with parallel diode

This ripple around the effective current depends on the coil inductance, coil suppression, PWM frequency, voltage level and duty ratio.

It is always recommended to start with 100% PWM duty ratio until the relay pullthrough and settles. The necessary time depends on excess voltage, relay type, etc., but 500ms should be sufficient. Otherwise it will take some time for the relay current to settle around the effective current.

In order to warrant a good relay performance with PWM it has to be made sure, that under all circumstances the coil current does not undercut the level of holding current plus the excess current for shock and vibration. Otherwise the armature and the contacts might open. Then the relay has to pull-in and pull-through again to settle. Repeated opening and closing the armature might cause humming noise. Unintended opening and closing the armature and contacts under load might cause contact welding.

Inductance

Relay coil inductances are in general relatively high, which result in comparatively small current ripples. But these values are not constant and vary strongly within one relay family or one type. The relay coil inductance depends among others on quite a few parameters, which are not under focus in a standard relay manufacturing process. Furthermore it heavily depends on the coil current (saturation) and status of the relay (armature open or closed).

Coil Suppression

In DC coil drivers coil suppression is done for protecting the relay driver from high coil switch-off voltage peaks. There are several options for this (see figure 2). For PWM coil drivers suppression is even more crucial, since the coil switch off occurs at PWM frequencies, i.e. up to several thousand times per second. Furthermore coil suppression reduces the ripple coil current, and thus the potential for dropping out since the coil current takes longer to decrease. Therefore from this perspective the stronger the suppression the better, i.e. best with parallel diode (upper circle in figure 2). On the other hand this case is exactly the worst for relay switching capability. For single drivers the best compromise is probably an anti parallel low voltage (3...9VDC) Z-diode (lower circle in figure 2). A Zener diode in parallel to the driver would cause a varying voltage clamp across the relay coil during switch-off due to varying supply voltage.

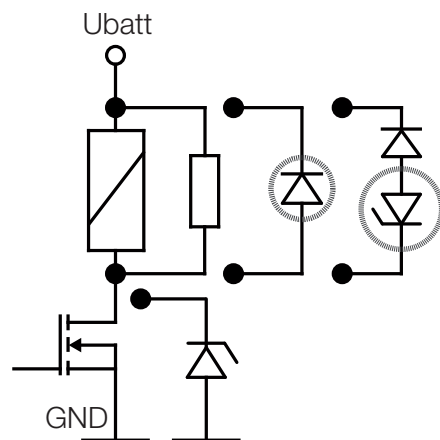

Figure 2: Relay coil low side driver with coil suppression options

Pulse Width Modulation (PWM) and Relays

Frequency:

As could be seen in figure 3 the higher the frequency the lower is the ripple current. Therefore the effective coil voltage could be chosen to be lower with keeping all the other parameters constant. We recommend a PWM frequency of minimum 20kHz.

PWM 12VDC, 558Hz, 10 kHz, 20 kHz 67%, Tamb. 23°C, Tcoil: 50°C

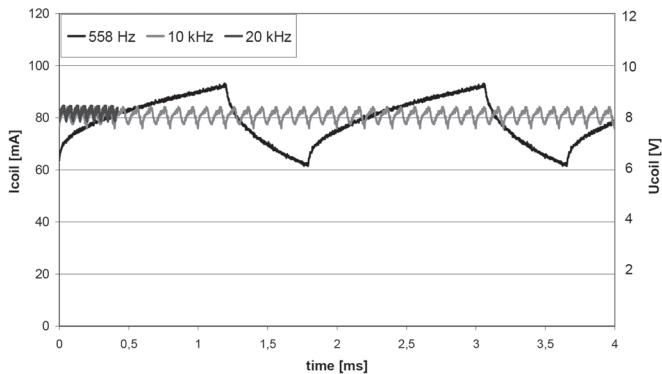

Figure 3: Effect of different PWM frequencies on ripple coil current on Power F relay with parallel diode

Duty Ratio

The effective coil voltage is the product of PWM duty ratio and supply voltage. However the supply voltage varies due to changes in system load (e.g. cranking) and alternator and battery status. Therefore the PWM duty ratio should be regulated according to the supply voltage. A tight regulation would be optimal for efficiency. But slight variation on the supply side would cause a continuous regulation of the PWM duty ratio. Furthermore regulation response time would need to be faster than 1ms to ensure, that the effective coil voltage does not undercut the required voltage limit.

Figures 4 and 5 show a PWM concept for a requirement of 8VDC effective coil voltage using a duty ratio regulation with 2VDC steps of the supply voltage.

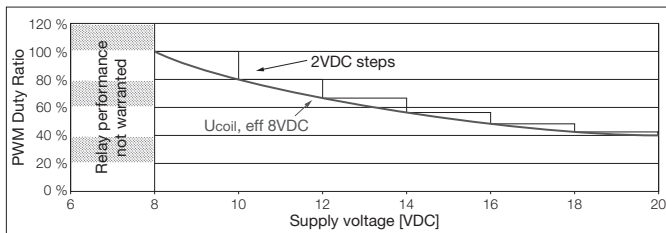

Figure 4: PWM duty ratio as a function of supply voltage with 2VDC step regulation

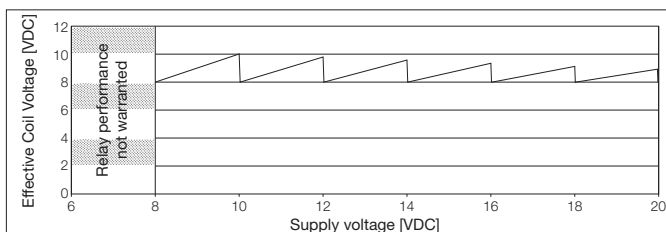

Figure 5: Effective coil voltage as function of supply voltage with 2VDC step regulation

Disturbing Noises

The application of PWM voltage across the relay coil causes magnetostriction of the iron within the relay magnetic system (core/frame/armature). The result is a slight audible noise if the relay was freely suspended. However when the relay soldered or welded onto a rigid lead frame that noise might be amplified. This depends on the lead frame (suspension, dimension, etc.) and the sound propagation and damping within the car. Choosing 20kHz PWM avoids disturbing noises for human beings but might cause problems to animals.

EMC (Electromagnetic Compatibility)

Due to the steep voltage and current edges EMC problems are possible. Therefore electromagnetic compatibility tests of the whole unit are necessary.

Компания «Life Electronics» занимается поставками электронных компонентов импортного и отечественного производства от производителей и со складов крупных дистрибьюторов Европы, Америки и Азии.

С конца 2013 года компания активно расширяет линейку поставок компонентов по направлению коаксиальный кабель, кварцевые генераторы и конденсаторы (керамические, пленочные, электролитические), за счёт заключения дистрибьюторских договоров

Мы предлагаем:

- Конкурентоспособные цены и скидки постоянным клиентам.
- Специальные условия для постоянных клиентов.
- Подбор аналогов.
- Поставку компонентов в любых объемах, удовлетворяющих вашим потребностям.
- Приемлемые сроки поставки, возможна ускоренная поставка.
- Доставку товара в любую точку России и стран СНГ.
- Комплексную поставку.
- Работу по проектам и поставку образцов.
- Формирование склада под заказчика.
- Сертификаты соответствия на поставляемую продукцию (по желанию клиента).
- Тестирование поставляемой продукции.
- Поставку компонентов, требующих военную и космическую приемку.
- Входной контроль качества.
- Наличие сертификата ISO.

В составе нашей компании организован Конструкторский отдел, призванный помогать разработчикам, и инженерам.

Конструкторский отдел помогает осуществить:

- Регистрацию проекта у производителя компонентов.
- Техническую поддержку проекта.
- Защиту от снятия компонента с производства.
- Оценку стоимости проекта по компонентам.
- Изготовление тестовой платы монтаж и пусконаладочные работы.



Тел: +7 (812) 336 43 04 (многоканальный)

Email: org@lifeelectronics.ru