

650V Cascode GaN FET in TO-247 (source tab)

Description

The TP65H035WSQA 650V, 35mΩ gallium nitride (GaN) FET is a normally-off automotive (AEC-Q101) qualified device. It combines state-of-the-art high voltage GaN HEMT and low voltage silicon MOSFET technologies—offering superior reliability and performance.

Transphorm GaN offers improved efficiency over silicon, through lower gate charge, lower crossover loss, and smaller reverse recovery charge.

Related Literature

- [AN0009](#): Recommended External Circuitry for GaN FETs
- [AN0003](#): Printed Circuit Board Layout and Probing
- [AN0010](#): Paralleling GaN FETs

Ordering Information

Part Number	Package	Package Configuration
TP65H035WSQA	3 lead TO-247	Source

TP65H035WSQA
TO-247
(top view)

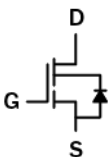
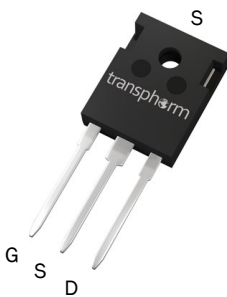

Cascode Schematic Symbol

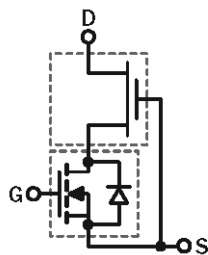

Cascode Device Structure

Features

- JEDEC-qualified GaN technology
- Junction temperature rating of 175C
- Dynamic $R_{DS(on)}$ production tested
- Robust design, defined by
 - Intrinsic lifetime tests
 - Wide gate safety margin
 - Transient over-voltage capability
- Very low Q_{RR}
- Reduced crossover loss
- RoHS compliant and Halogen-free packaging

Benefits

- Enables AC-DC bridgeless totem-pole PFC designs
 - Increased power density
 - Reduced system size and weight
 - Overall lower system cost
- Achieves increased efficiency in both hard- and soft-switched circuits
- Easy to drive with commonly-used gate drivers
- GSD pin layout improves high speed design

Applications

- Automotive
- Datacom
- Broad industrial
- PV inverter

Key Specifications	
V_{DS} (V) min	650
$V_{(TR)DSS}$ (V) max	800
$R_{DS(on)}$ (mΩ) max*	41
Q_{RR} (nC) typ	178
Q_G (nC) typ	24

* Dynamic $R_{DS(on)}$; see Figures 13 and 14

Common Topology Power Recommendations	
CCM bridgeless totem-pole*	3980W max
Hard-switched inverter**	4690W max

Conditions: $F_{SW}=45kHz$; $T_J=115^\circ C$; $T_{HEATSINK}=90^\circ C$; insulator between device and heatsink (6 mil Sil-Pad® K-10); power de-rates at lower voltages with constant current

* $V_{IN}=230V_{AC}$; $V_{OUT}=390V_{DC}$

** $V_{IN}=380V_{DC}$; $V_{OUT}=240V_{AC}$

TP65H035WSQA

Absolute Maximum Ratings (T_c=25 °C unless otherwise stated.)

Symbol	Parameter		Limit Value	Unit
V _{DSS}	Drain to source voltage (T _J = -55 °C to 150 °C)		650	V
V _{(TR)DSS}	Transient drain to source voltage ^a		800	
V _{GSS}	Gate to source voltage		±20	
P _D	Maximum power dissipation @T _c =25 °C		187	W
I _D	Continuous drain current @T _c =25 °C ^b		47.2	A
	Continuous drain current @T _c =100 °C ^b		33.4	A
I _{DM}	Pulsed drain current (pulse width: 10µs)		240	A
(di/dt) _{RDMC}	Reverse diode di/dt, repetitive ^c		1800	A/µs
(di/dt) _{RDMT}	Reverse diode di/dt, transient ^d		3800	A/µs
T _C	Operating temperature	Case	-55 to +175	°C
T _J		Junction	-55 to +175	°C
T _S	Storage temperature		-55 to +175	°C
T _{SOLD}	Soldering peak temperature ^e		260	°C
-	Mounting Torque		80	N cm

Notes:

- In off-state, spike duty cycle D<0.01, spike duration <1µs
- For increased stability at high current operation, see Circuit Implementation on page 3
- Continuous switching operation
- ≤300 pulses per second for a total duration ≤20 minutes
- For 10 sec., 1.6mm from the case

Thermal Resistance

Symbol	Parameter	Maximum	Unit
R _{θJC}	Junction-to-case	0.8	°C/W
R _{θJA}	Junction-to-ambient	40	°C/W

TP65H035WSQA

Circuit Implementation

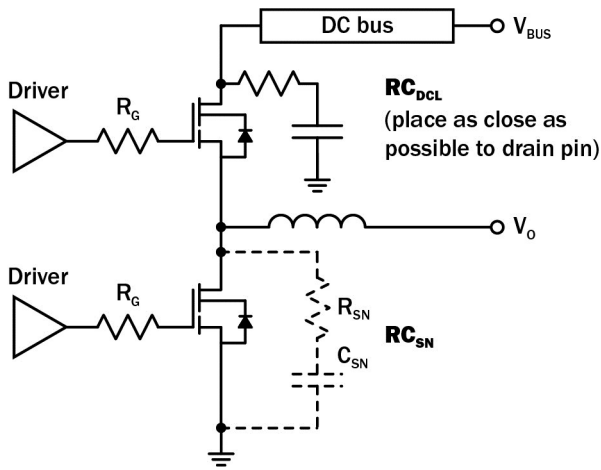

Simplified Half-bridge Schematic

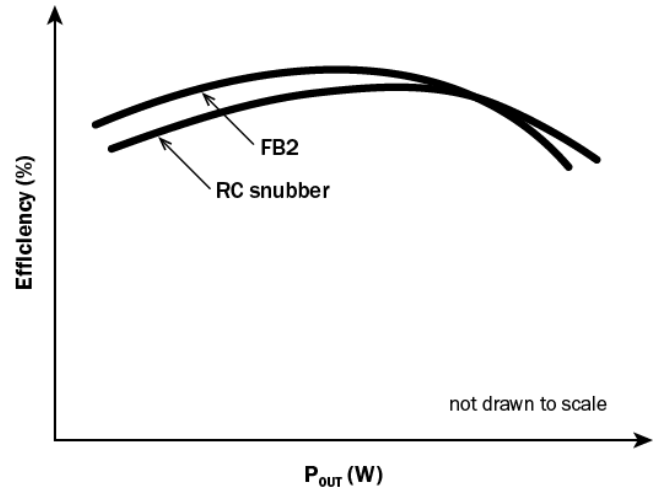

Ferrite Bead and RC Snubber Efficiency vs Output Power

Recommended gate drive: (0V, 12V) with $R_G = 30\Omega$

Required DC Link RC Snubber (RC_{DCL}) ^a	Recommended Switching Node RC Snubber (RC_{SN}) ^{b, c}
[10nF + 8Ω] x 2	200pF + 5Ω

Notes:

- RC_{DCL} should be placed as close as possible to the drain pin
- A switching node RC snubber (C, R) is recommended for high switching currents (>70% of I_{RDMC1} or I_{RDMC2} ; see page 5 for I_{RDMC1} and I_{RDMC2})
- I_{RDM} values can be increased by increasing R_G and C_{SN}

TP65H035WSQA

Electrical Parameters (T_J=25 °C unless otherwise stated)

Symbol	Parameter	Min	Typ	Max	Unit	Test Conditions
Forward Device Characteristics						
V _{(BL)DSS}	Drain-source voltage	650	—	—	V	V _{GS} =0V
V _{GS(th)}	Gate threshold voltage	3.4	4	4.5	V	V _{DS} =V _{GS} , I _D =1mA
ΔV _{GS(th)} /T _J	Gate threshold voltage temperature coefficient	—	-6.5	—	mV/°C	
R _{DS(on)eff}	Drain-source on-resistance ^a	—	35	41	mΩ	V _{GS} =10V, I _D =32A
		—	84	—		V _{GS} =10V, I _D =32A, T _J =175 °C
I _{DSS}	Drain-to-source leakage current	—	2	25	μA	V _{DS} =650V, V _{GS} =0V
		—	30	—		V _{DS} =650V, V _{GS} =0V, T _J =175 °C
I _{GSS}	Gate-to-source forward leakage current	—	—	400	nA	V _{GS} =20V
	Gate-to-source reverse leakage current	—	—	-400		V _{GS} =-20V
C _{ISS}	Input capacitance	—	1500	—	pF	V _{GS} =0V, V _{DS} =400V, f=1MHz
C _{OSS}	Output capacitance	—	196	—		
C _{RSS}	Reverse transfer capacitance	—	10	—		
C _{O(er)}	Output capacitance, energy related ^b	—	290	—	pF	V _{GS} =0V, V _{DS} =0V to 400V
C _{O(tr)}	Output capacitance, time related ^c	—	445	—		
Q _G	Total gate charge	—	24	—	nC	V _{DS} =400V, V _{GS} =0V to 10V, I _D =32A
Q _{GS}	Gate-source charge	—	9	—		
Q _{GD}	Gate-drain charge	—	5	—		
Q _{OSS}	Output charge	—	178	—	nC	V _{GS} =0V, V _{DS} =0V to 400V
t _{D(on)}	Turn-on delay	—	69	—	ns	V _{DS} =400V, V _{GS} =0V to 12V, I _D =32A, R _G = 30Ω
t _R	Rise time	—	14	—		
t _{D(off)}	Turn-off delay	—	98	—		
t _F	Fall time	—	12	—		

Notes:

- Dynamic on-resistance; see Figures 17 and 18 for test circuit and conditions
- Equivalent capacitance to give same stored energy as V_{DS} rises from 0V to 400V
- Equivalent capacitance to give same charging time as V_{DS} rises from 0V to 400V

TP65H035WSQA

Electrical Parameters (T_J=25 °C unless otherwise stated)

Symbol	Parameter	Min	Typ	Max	Unit	Test Conditions
Reverse Device Characteristics						
I _S	Reverse current	—	—	30.9	A	V _{GS} =0V, T _C =100 °C ≤20% duty cycle
V _{SD}	Reverse voltage ^a	—	1.8	—	V	V _{GS} =0V, I _S =32A
		—	1.3	—		V _{GS} =0V, I _S =16A
t _{RR}	Reverse recovery time	—	65	—	ns	I _S =32A, V _{DD} =400V, di/dt=1000A/μs
Q _{RR}	Reverse recovery charge	—	178	—	nC	
(di/dt) _{RDMC}	Reverse diode di/dt, repetitive ^b	—	—	1800	A/μs	
I _{RDMC1}	Reverse diode switching current, repetitive (dc) ^{c, e}	—	—	28	A	Circuit implementation and parameters on page 3
I _{RDMC2}	Reverse diode switching current, repetitive (ac) ^{c, e}	—	—	35	A	Circuit implementation and parameters on page 3
(di/dt) _{RDMT}	Reverse diode di/dt, transient ^d	—	—	3800	A/μs	
I _{RDMT}	Reverse diode switching current, transient ^{d, e}	—	—	45	A	Circuit implementation and parameters on page 3

Notes:

- Includes dynamic R_{DS(on)} effect
- Continuous switching operation
- Definitions: dc = dc-to-dc converter topologies; ac = inverter and PFC topologies, 50-60Hz line frequency
- ≤300 pulses per second for a total duration ≤20 minutes
- I_{RDM} values can be increased by increasing R_G and C_{SN} on page 3

TP65H035WSQA

Typical Characteristics ($T_C=25^\circ\text{C}$ unless otherwise stated)

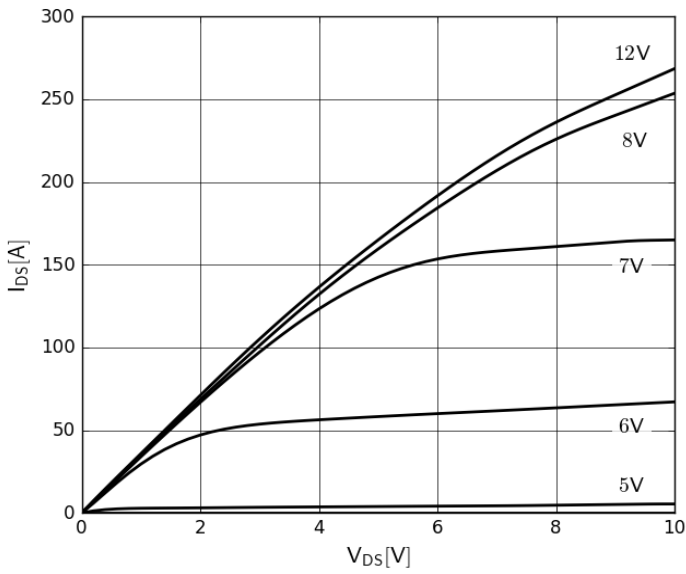

Figure 1. Typical Output Characteristics $T_J=25^\circ\text{C}$
Parameter: V_{GS}

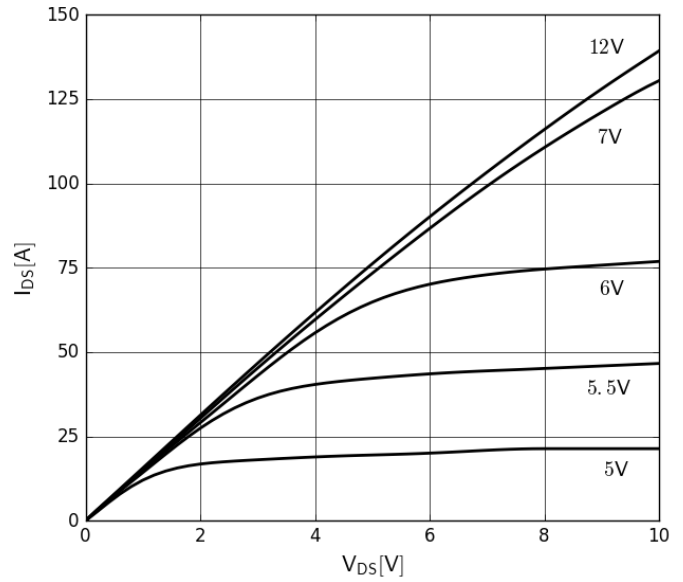

Figure 2. Typical Output Characteristics $T_J=175^\circ\text{C}$
Parameter: V_{GS}

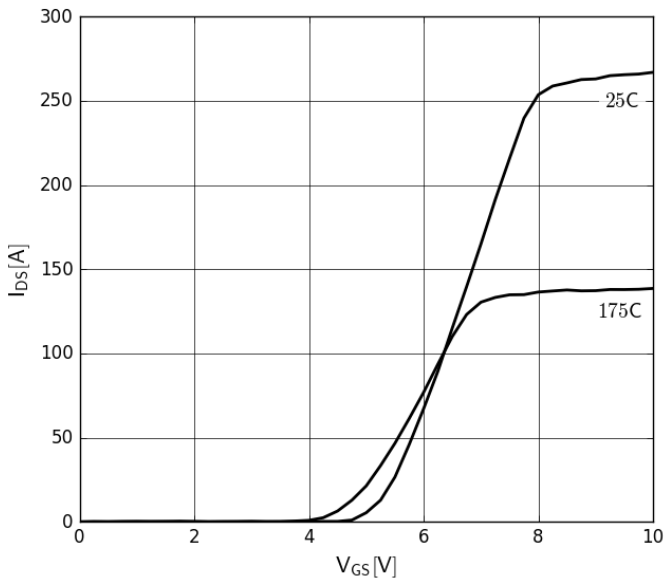

Figure 3. Typical Transfer Characteristics
 $V_{DS}=10\text{V}$, parameter: T_J

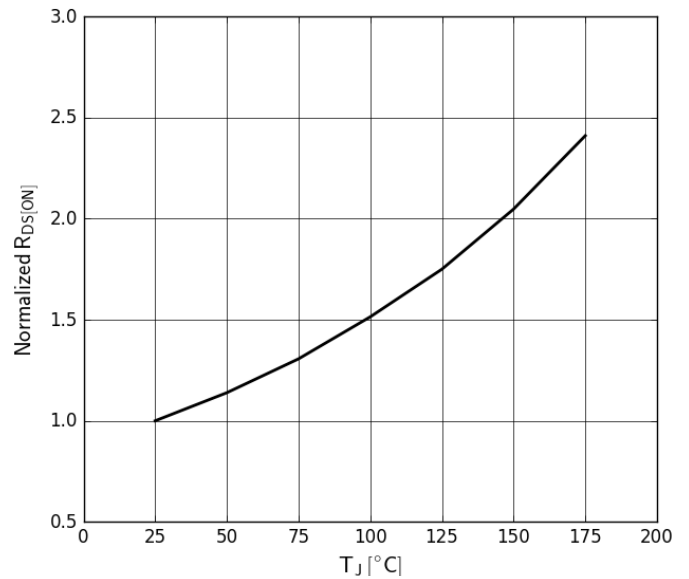

Figure 4. Normalized On-Resistance
 $I_D=30\text{A}$, $V_{GS}=8\text{V}$

TP65H035WSQA

Typical Characteristics ($T_C=25^\circ\text{C}$ unless otherwise stated)

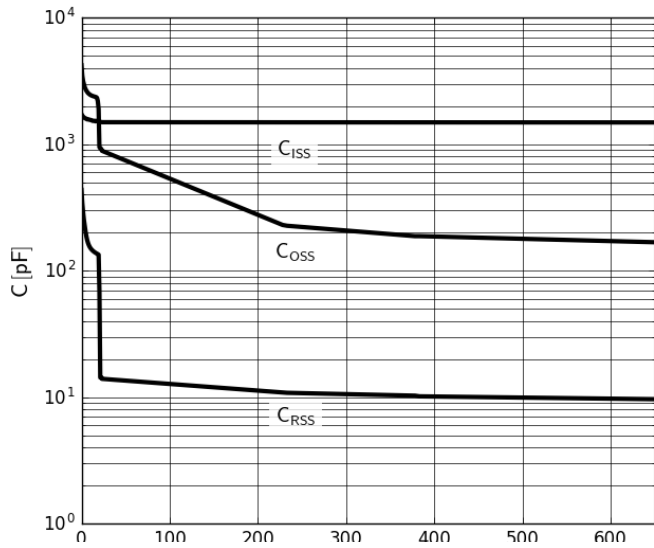

Figure 5. Typical Capacitance
 $V_{GS}=0V$, $f=1MHz$

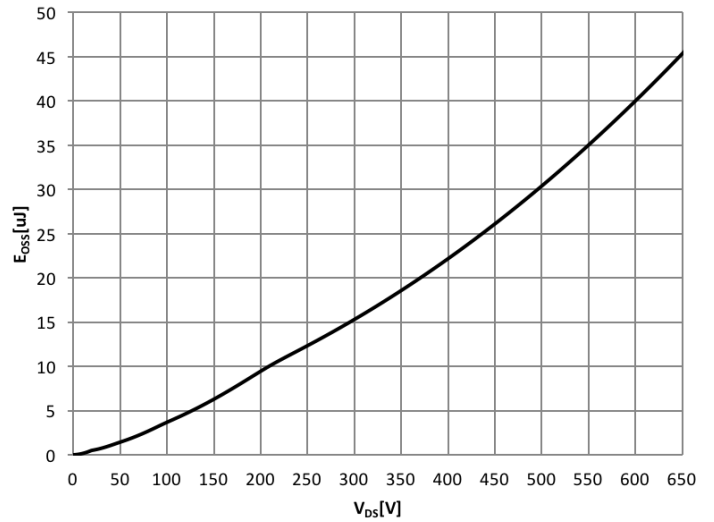

Figure 6. Typical C_{OSS} Stored Energy

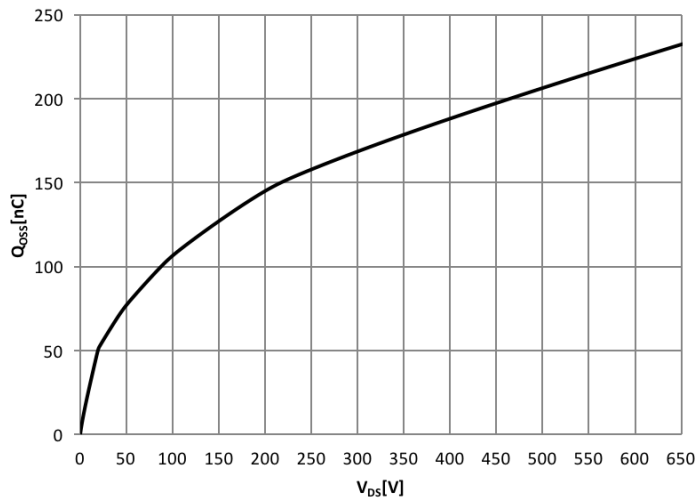

Figure 7. Typical Q_{OSS}

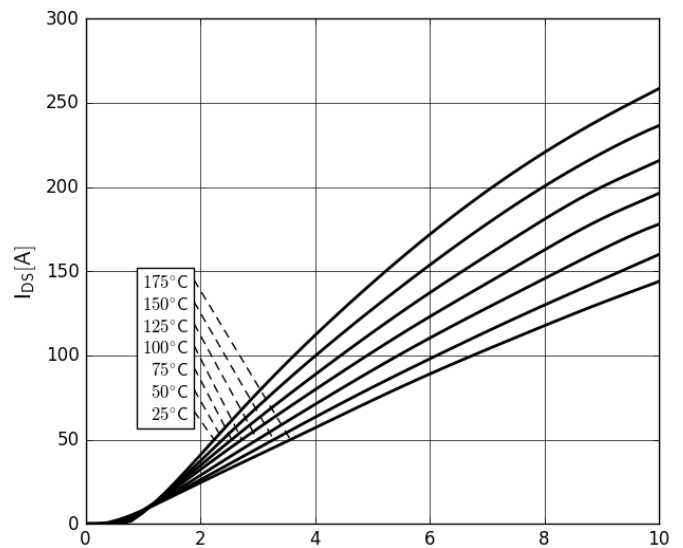

Figure 8. Forward Characteristics of Rev. Diode
 $I_S=f(V_{SD})$; parameter: T_J

TP65H035WSQA

Typical Characteristics ($T_c=25^\circ\text{C}$ unless otherwise stated)

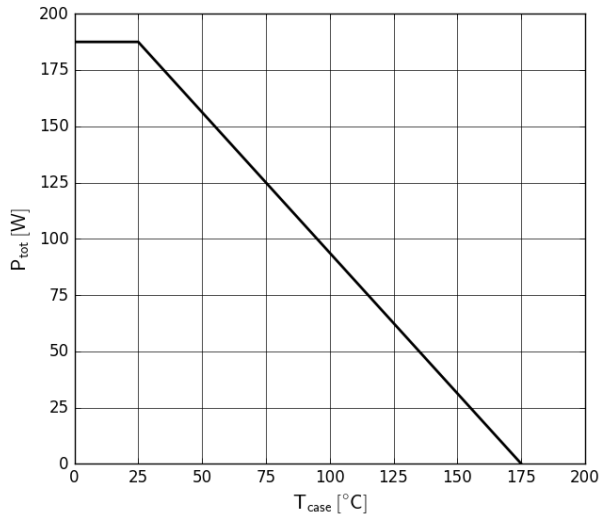

Figure 9. Power Dissipation

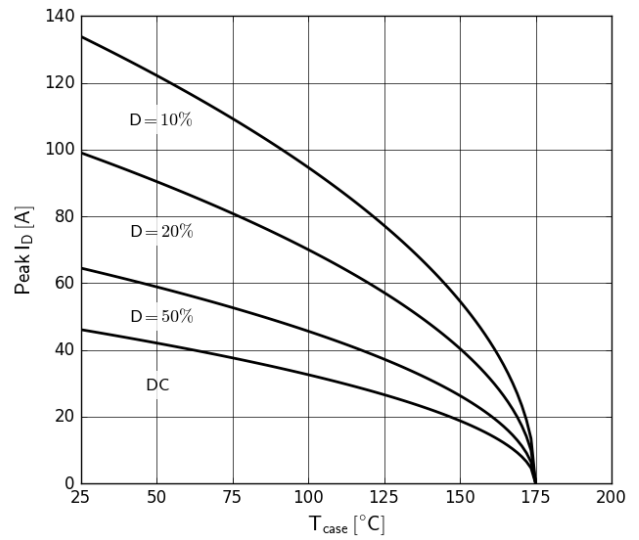

Figure 10. Current Derating

Pulse width $\leq 10\mu\text{s}$, $V_{GS} \geq 10\text{V}$

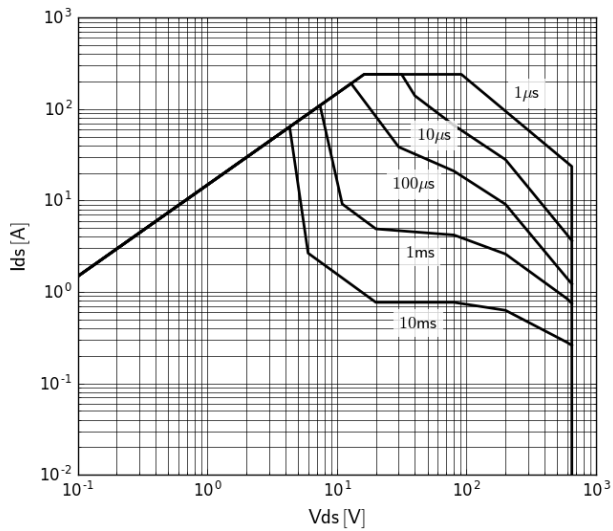

Figure 11. Safe Operating Area $T_c=25^\circ\text{C}$

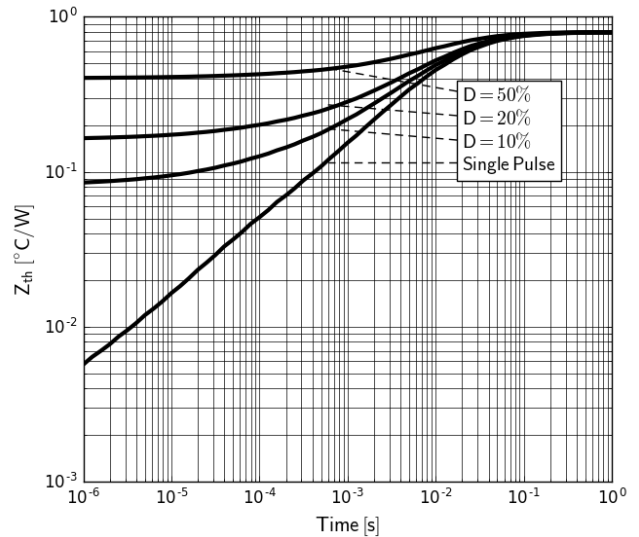

Figure 12. Transient Thermal Resistance

TP65H035WSQA

Test Circuits and Waveforms

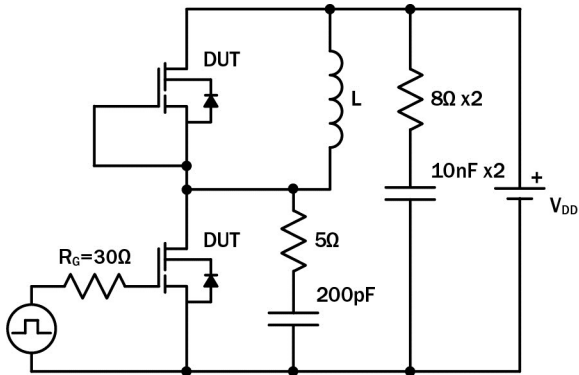

Figure 13. Switching Time Test Circuit
(see Circuit Implementation on page 3 for methods to ensure clean switching)

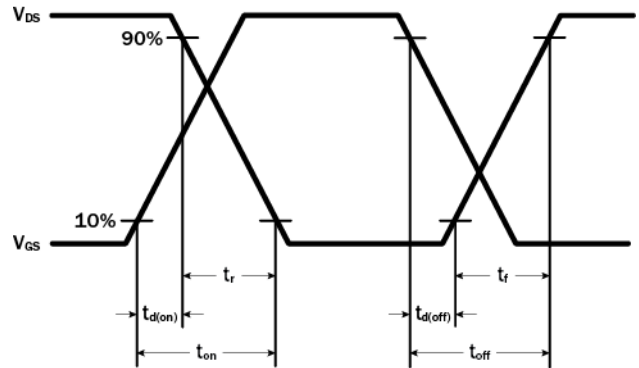

Figure 14. Switching Time Waveform

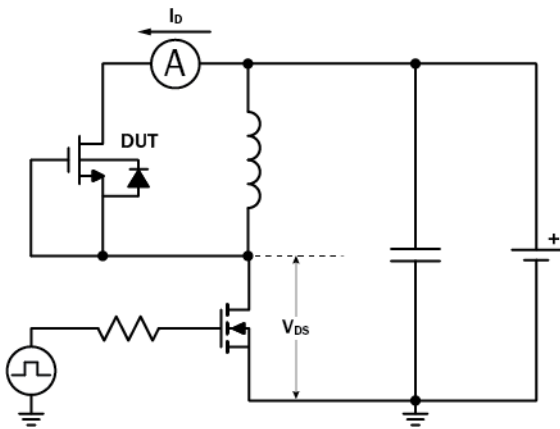

Figure 15. Diode Characteristics Test Circuit

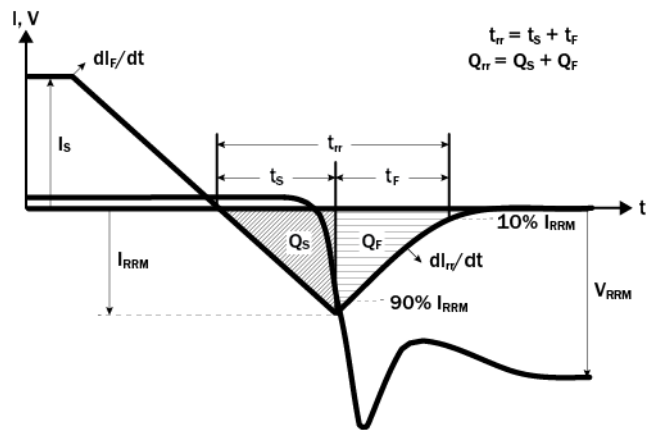

Figure 16. Diode Recovery Waveform

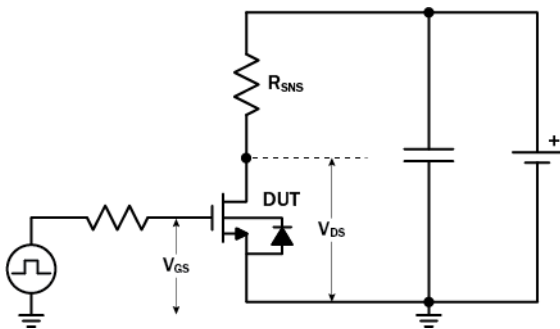

Figure 17. Dynamic $R_{DS(on)}$ Test Circuit

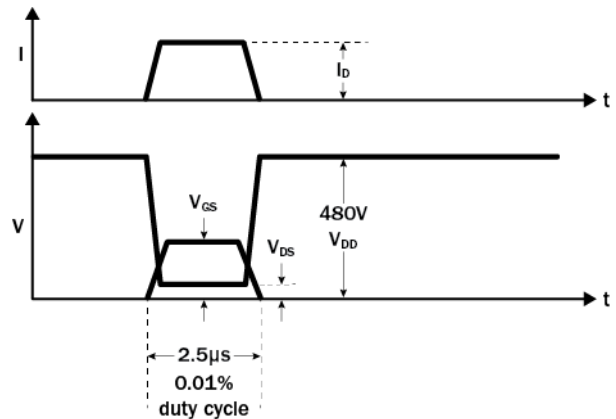

Figure 18. Dynamic $R_{DS(on)}$ Waveform

TP65H035WSQA

Design Considerations

The fast switching of GaN devices reduces current-voltage crossover losses and enables high frequency operation while simultaneously achieving high efficiency. However, taking full advantage of the fast switching characteristics of GaN switches requires adherence to specific PCB layout guidelines and probing techniques.

Before evaluating Transphorm GaN devices, see application note [Printed Circuit Board Layout and Probing for GaN Power Switches](#). The table below provides some practical rules that should be followed during the evaluation.

When Evaluating Transphorm GaN Devices:

DO	DO NOT
Minimize circuit inductance by keeping traces short, both in the drive and power loop	Twist the pins of TO-220 or TO-247 to accommodate GDS board layout
Minimize lead length of TO-220 and TO-247 package when mounting to the PCB	Use long traces in drive circuit, long lead length of the devices
Use shortest sense loop for probing; attach the probe and its ground connection directly to the test points	Use differential mode probe or probe ground clip with long wire
See AN0003 : Printed Circuit Board Layout and Probing	

GaN Design Resources

The complete technical library of GaN design tools can be found at transphormusa.com/design:

- Evaluation kits
- Application notes
- Design guides
- Simulation models
- Technical papers and presentations

TP65H035WSQA

Mechanical

3 Lead TO-247 Package

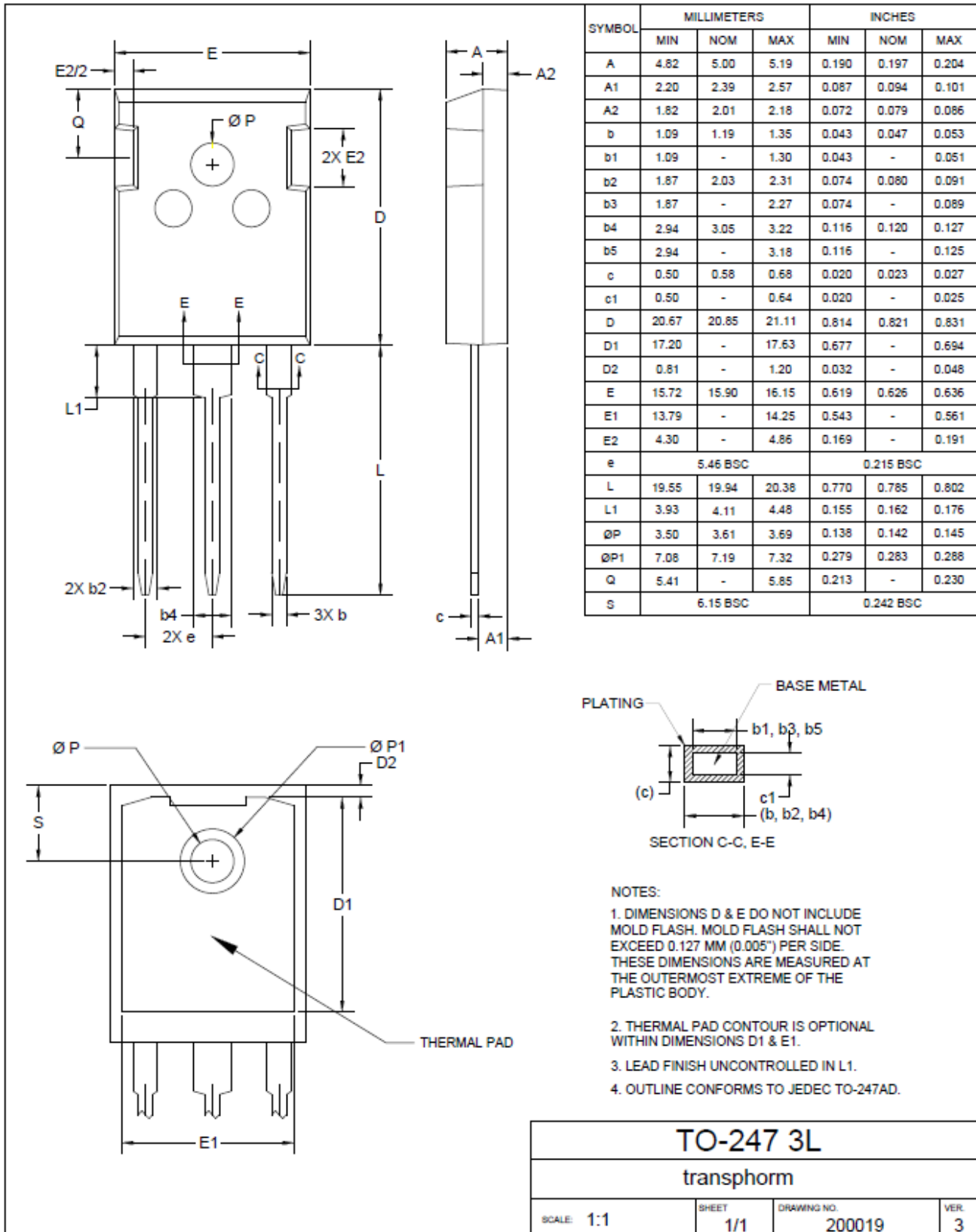

TP65H035WSQA

Revision History

Version	Date	Change(s)
0	9/18/2017	Create preliminary datasheet
1	2/1/2019	Datasheet completed

Компания «Life Electronics» занимается поставками электронных компонентов импортного и отечественного производства от производителей и со складов крупных дистрибьюторов Европы, Америки и Азии.

С конца 2013 года компания активно расширяет линейку поставок компонентов по направлению коаксиальный кабель, кварцевые генераторы и конденсаторы (керамические, пленочные, электролитические), за счёт заключения дистрибьюторских договоров

Мы предлагаем:

- Конкурентоспособные цены и скидки постоянным клиентам.
- Специальные условия для постоянных клиентов.
- Подбор аналогов.
- Поставку компонентов в любых объемах, удовлетворяющих вашим потребностям.
- Приемлемые сроки поставки, возможна ускоренная поставка.
- Доставку товара в любую точку России и стран СНГ.
- Комплексную поставку.
- Работу по проектам и поставку образцов.
- Формирование склада под заказчика.
- Сертификаты соответствия на поставляемую продукцию (по желанию клиента).
- Тестирование поставляемой продукции.
- Поставку компонентов, требующих военную и космическую приемку.
- Входной контроль качества.
- Наличие сертификата ISO.

В составе нашей компании организован Конструкторский отдел, призванный помогать разработчикам, и инженерам.

Конструкторский отдел помогает осуществить:

- Регистрацию проекта у производителя компонентов.
- Техническую поддержку проекта.
- Защиту от снятия компонента с производства.
- Оценку стоимости проекта по компонентам.
- Изготовление тестовой платы монтаж и пусконаладочные работы.



Тел: +7 (812) 336 43 04 (многоканальный)

Email: org@lifeelectronics.ru