

**Revision History****1G (64M x 16) Low Power DDR SDRAM 60ball FBGA Package  
AS4C64M16MD1A-5BIN**

Revision	Details	Date
Rev 1.0	Preliminary datasheet	Jan 2018

## DDR Sync DRAM Features

### • Functionality

- Double-data-rate architecture ; two data transfers per CLK cycle.
- Bidirectional data strobe per byte data (DQS).
- No DLL ; CLK to DQS is not Synchronized.
- Differential CLK inputs( CLK and /CLK ).
- Commands entered on each positive CLK edge.
- DQS edge-aligned with data for Reads; center-aligned with data for Writes.
- Four internal banks for concurrent operation.
- Data masks (DM) for masking write data-one mask per byte.
- Programmable burst lengths : 2, 4, 8, 16.
- Programmable CAS Latency : 2, 3.
- Concurrent auto pre-charge option is supported.
- Auto refresh and self refresh modes.
- Status read register (SRR)
- LVCMOS-compatible inputs.

### • Configuration

- 64 Meg X 16 (16 Meg X 16 X 4Bank ).

### • Low Power Features

- Low voltage power supply.
- Auto TCSR (Temperature Compensated Self Refresh).
- Partial Array Self Refresh power-saving mode.
- Deep Power Down Mode.
- Driver Strength Control.

### • Operating Temperature Ranges

- Industrial (-40°C to +85°C).

### • Package

- 60-Ball FBGA ( 8 X 9 X 0.8mm )

### • Functional Description

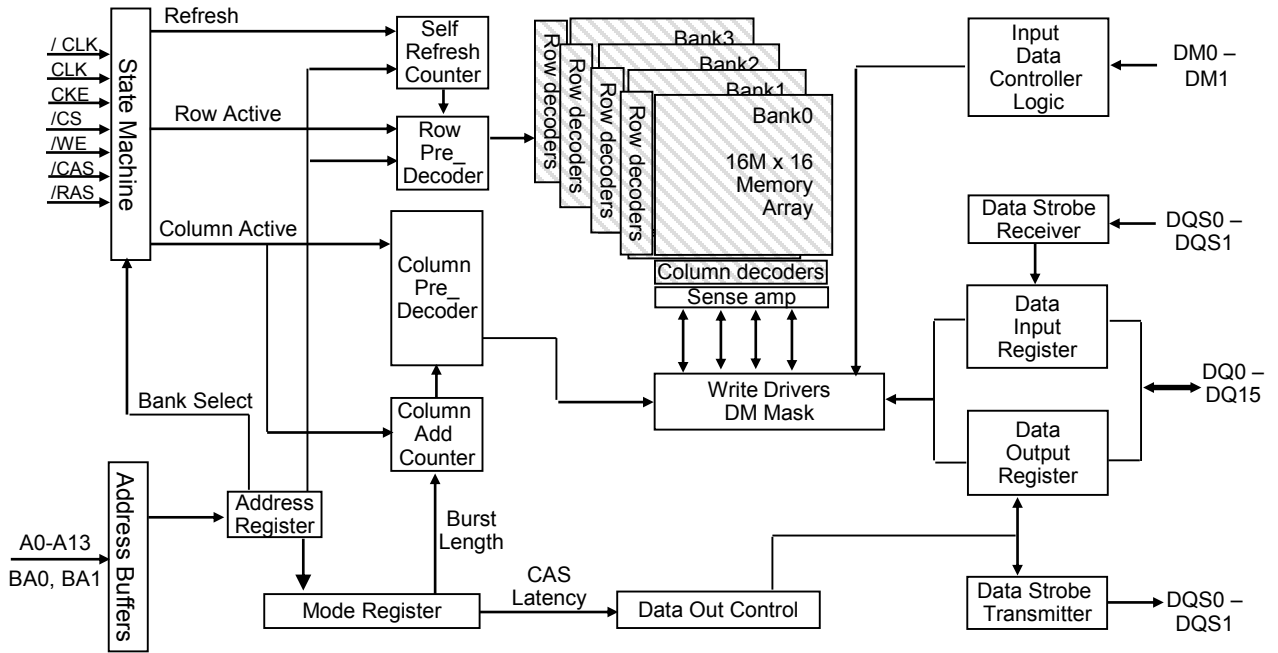
The AS4C64M16MD1A Family is high-performance CMOS Dynamic RAMs (DRAM) organized as 64M x 16. These devices feature advanced circuit design to provide low active current and extremely low standby current. The device is compatible with the JEDEC standard Low Power DDR SDRAM specifications.

**Table 1. Ordering Information**

Product part No	Org	Temperature	Max Clock (MHz)	Package
AS4C64M16MD1A-5BIN	64M x 16	Industrial -40°C to 85°C	200 Hz	60-ball FBGA

**Table 2. Speed Grade Information**

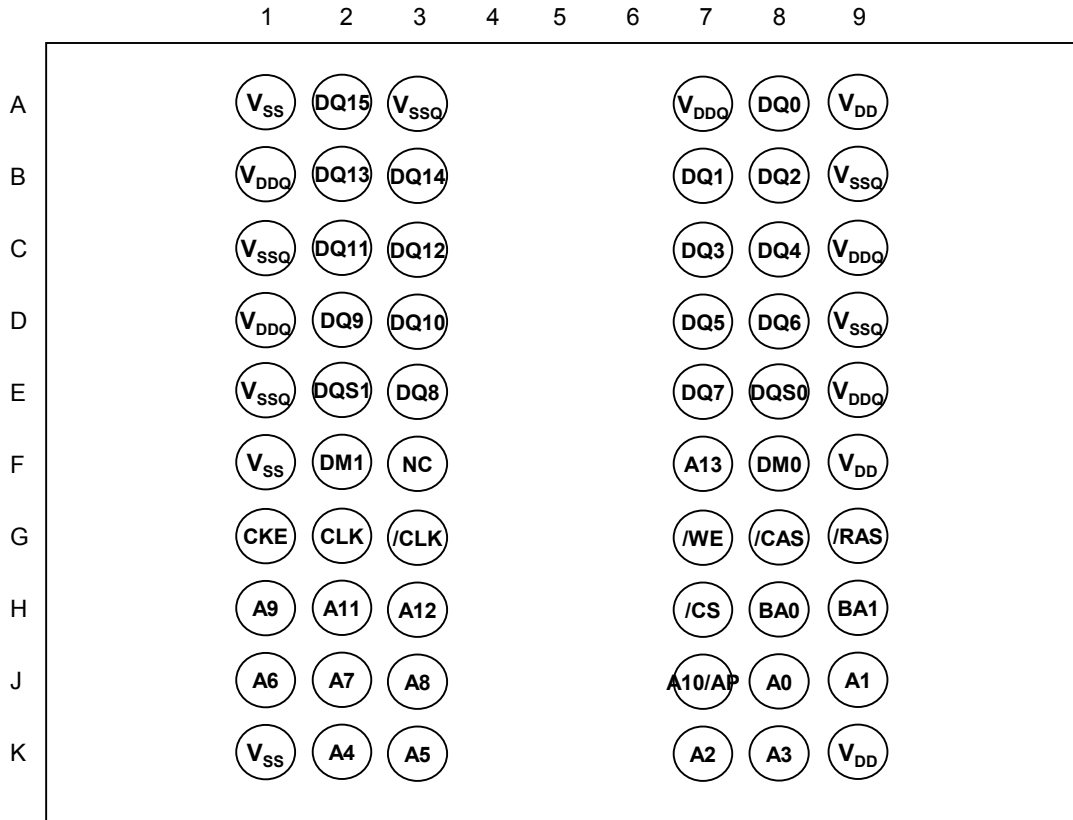
Speed Grade	Clock Frequency	CAS Latency	t <sub>RCD</sub> (ns)	t <sub>RP</sub> (ns)
DDR1-400	200 Hz	3	15	15

**Logic Block Diagram**


**Pin Configuration**

60 ball 0.8mm pitch FBGA(8mm x 9mm)

Top View



## General Description

The 1Gb Low Power DDR SDRAM is a high-speed CMOS, dynamic random-access memory containing 1,073,741,824 bits. It is internally configured as a quad-bank DRAM. Each of the 268,435,456-bit banks is organized as 16,384 rows by 1,024 columns by 16 bits.

The 1Gb Low Power DDR SDRAM uses a double data rate architecture to achieve high-speed operation. The double data rate architecture is essentially a  $2n$ -prefetch architecture with an interface designed to transfer four data words per clock cycle at the I/O balls. A single read or write access for the 1Gb DDR SDRAM effectively consists of a single  $2n$ -bit wide, one-clock-cycle data transfer at the internal DRAM core and two corresponding  $n$ -bit wide, one-half-clock-cycle data transfers at the I/O balls.

A bidirectional data strobe (DQS) is transmitted externally, along with data, for use in data capture at the receiver. DQS is a strobe transmitted by the Low Power DDR SDRAM during READs and by the memory controller during WRITEs. DQS is edge-aligned with data for READs and center-aligned with data for WRITEs. The x16 offering has two data strobes.

The 1Gb Low Power DDR SDRAM operates from a differential clock (CLK and /CLK); the crossing of CLK going HIGH and /CLK going LOW will be referred to as the positive edge of CLK. Commands (address and control signals) are registered at every positive edge of CLK. Input data is registered on both edges of DQS, and output data is referenced to both edges of DQS, as well as to both edges of CLK.

Read and write accesses to the Low Power DDR SDRAM are burst oriented; accesses start at a selected location and continue for a programmed number of locations in a programmed sequence. Accesses begin with the registration of an ACTIVE command, which is then followed by a READ or WRITE command. The address bits registered coincident with the ACTIVE command are used to select the bank and row to be accessed. The address bits registered coincident with the READ or WRITE command are used to select the bank and the starting column location for the burst access.

The Low Power DDR SDRAM provides for programmable READ or WRITE burst lengths of 2,4,8 or 16. An auto precharge function may be enabled to provide a self-timed row precharge that is initiated at the end of the burst access.

As with standard SDR SDRAMs, the pipelined, multibank architecture of Low Power DDR SDRAMs allows for concurrent operation, thereby providing high effective bandwidth by hiding row precharge and activation time.

An auto-refresh mode is provided, along with a power saving power-down mode. Self refresh mode offers temperature compensation through an on-chip temperature sensor and partial array self refresh, which allow users to achieve additional power saving. The temperature sensor is enabled by default and the partial array self refresh can be programmed through the extended mode register.

### Notes :

1. Throughout the data sheet, the various figures and text refer to DQs as "DQ." The DQ term is to be interpreted as any and all DQ collectively, unless specifically stated otherwise. Additionally, the x16 is divided into two bytes. For the first byte (DQ0–DQ7) DM refers to DM0 and DQS refers to DQS0. For the second byte (DQ8–DQ15) DM refers to DM1 and DQS refers to DQS1.
2. Complete functionality is described throughout the document and any page or diagram may have been simplified to convey a topic and may not be inclusive of all requirements.
3. Any specific requirement takes precedence over a general statement.

**Pin Description**

Symbol	Type	Description
CLK, /CLK	Input	Clock: CLK is the system clock input. CLK and /CLK are differential clock inputs. All address and control input signals are sampled on the crossing of the positive edge of CLK and negative edge of /CLK. Input and output data is referenced to the crossing of CLK and /CLK (both directions of the crossing).
CKE	Input	Clock enable: CKE HIGH activates and CKE LOW deactivates the internal clock signals, input buffers, and output drivers. Taking CKE LOW allows PRECHARGE power-down and SELF REFRESH operations (all banks idle), or ACTIVE power-down (row active in any bank). CKE is synchronous for all functions except SELF REFRESH exit. All input buffers (except CKE) are disabled during power-down and self refresh modes.
/CS	Input	Chip select: /CS enables (registered LOW) and disables (registered HIGH) the command decoder. All commands are masked when /CS is registered HIGH. /CS provides for external bank selection on systems with multiple banks. /CS is considered part of the command code.
/RAS, /CAS, /WE	Input	Command inputs: /RAS, /CAS, and /WE (along with /CS) define the command being entered.
DM0-DM1	Input	Input data mask: DM is an input mask signal for write data. Input data is masked when DM is sampled HIGH along with that input data during a WRITE access. DM is sampled on both edges of DQS. Although DM balls are input-only, the DM loading is designed to match that of DQ and DQS balls. For the x16, DM0 corresponds to DQ0 – DQ7, DM1 corresponds to DQ8–DQ15.
BA0, BA1	Input	Bank address inputs: BA0 and BA1 define to which bank an ACTIVE, READ, WRITE, or PRECHARGE command is applied. BA0 and BA1 also determine which mode register (standard mode register or extended mode register) is loaded during a LOAD MODE REGISTER command.
A0-A13	Input	Address inputs: Provide the row address for ACTIVE commands, and the column address and auto pre-charge bit (A10) for READ or WRITE commands, to select one location out of the memory array in the respective bank. During a PRECHARGE command, A10 determines whether the PRECHARGE applies to one bank (A10 LOW, bank selected by BA0, BA1) or all banks (A10 HIGH). The address inputs also provide the op-code during a LOAD MODE REGISTER command. BA0 and BA1 define which mode register (mode register or extended mode register) is loaded during the LOAD MODE REGISTER command. For 1Gb(X16), Row Address : A0 ~ A13, Column Address: A0 ~ A9.
DQ0-DQ15	I/O	Data input/output: Data bus for x16.
DQS0-DQS1	I/O	Data strobe: Output with read data, input with write data. DQS is edge aligned with read data, centered in write data. It is used to capture data. For the x16, DQS0 corresponds to DQ0 – DQ7, DQS1 corresponds to DQ8–DQ15.
TQ	Output	Temperature sensor output : TQ High when LPDDR Tj exceeds 85°C. When TQ is 'High', self refresh is not supported.
VDDQ	Supply	DQ Power: Provide isolated power to DQs for improved noise immunity.
VSSQ	Supply	DQ Ground: Provide isolated ground to DQs for improved noise immunity.
VDD	Supply	Power Supply: Voltage dependant on option.
VSS	Supply	Ground.

## Functional Description

The 1Gb Low Power DDR SDRAM is a high-speed CMOS, dynamic random-access memory containing 1,073,741,824 bits. It is internally configured as a quad-bank DRAM. Each of the 268,435,456-bit banks is organized as 16,384 rows by 1,024 columns by 16 bits.

The 1Gb Low Power DDR SDRAM uses a double data rate architecture to achieve high-speed operation. The double data rate architecture is essentially a  $2n$ -prefetch architecture, with an interface designed to transfer four data words per clock cycle at the I/O balls. single read or write access for the 1Gb Low Power DDR SDRAM consists of a single  $2n$ -bit wide, one-clock-cycle data transfer at the internal DRAM core and two corresponding  $n$ -bit wide, one-half-clock-cycle data transfers at the I/O balls.

Read and write accesses to the Low Power DDR SDRAM are burst oriented; accesses start at a selected location and continue for a programmed number of locations in a programmed sequence. Accesses begin with the registration of an ACTIVE command, which is then followed by a READ or WRITE command.

The address bits registered coincident with the ACTIVE command are used to select the bank and row to be accessed (BA0, BA1 select the bank; A0–A13 select the row). The address bits registered coincident with the READ or WRITE command are used to select the starting column location for the burst access.

It should be noted that the DLL signal that is typically used on standard DDR devices is not necessary on the Low Power DDR SDRAM. It has been omitted to save power.

Prior to normal operation, the Low Power DDR SDRAM must be initialized. The following sections provide detailed information covering device initialization, register definition, command descriptions and device operation.

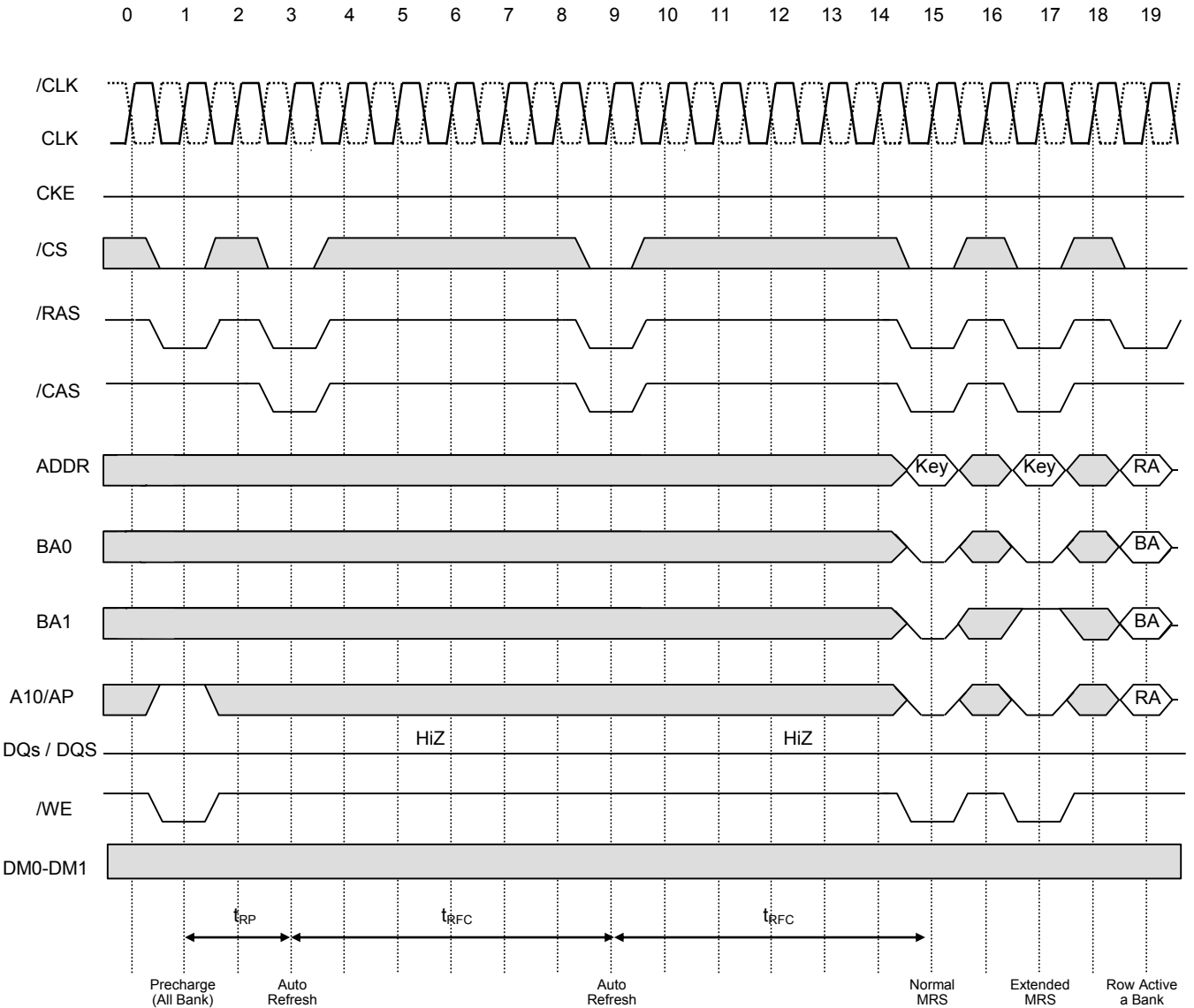
## Initialization

Low Power DDR SDRAMs must be powered up and initialized in a predefined manner. Operational procedures other than those specified may result in undefined operation.

If there is an interruption to the device power, the initialization routine should be followed to ensure proper functionality of the Low Power DDR SDRAM. The clock stop feature is not available until the device has been properly initialized.

To properly initialize the Low Power DDR SDRAM, this sequence must be followed:

1. To prevent device latch-up, it is recommended the core power (VDD) and I/O power (VDDQ) be from the same power source and brought up simultaneously. If separate power sources are used, VDD must lead VDDQ.
2. Once power supply voltages are stable and the CKE has been driven HIGH, it is safe to apply the clock.
3. Once the clock is stable, a 200 $\mu$ s (minimum) delay is required by the Low Power DDR SDRAM prior to applying an executable command. During this time, NOP or DESELECT commands must be issued on the command bus.
4. Issue a PRECHARGE ALL command.
5. Issue NOP or DESELECT commands for at least tRP time.
6. Issue an AUTO REFRESH command followed by NOP or DESELECT commands for at least tRFC time. Issue a second AUTO REFRESH command followed by NOP or DESELECT commands for at least tRFC time. As part of the individualization sequence, two AUTO REFRESH commands must be issued. Typically, both of these commands are issued at this stage as described above. Alternately, the second AUTO-REFRESH command and NOP or DESELECT sequence can be issued between steps 10 and 11.
7. Using the LOAD MODE REGISTER command, load the standard mode register as desired.
8. Issue NOP or DESELECT commands for at least tMRD time.
9. Using the LOAD MODE REGISTER command, load the extended mode register to the desired operating modes. Note that the sequence in which the standard and extended mode registers are programmed is not critical.
10. Issue NOP or DESELECT commands for at least tMRD time.
11. The Low Power DDR SDRAM has been properly initialized and is ready to receive any valid command.

**Figure 1. Initialize and Load Mode Register<sup>[1,2,3]</sup>**

**Note :**

1. The two AUTO REFRESH commands at T3 and T9 may be applied before either LOAD MODE REGISTER (LMR) command.
2. PRE = PRECHARGE command, LMR = LOAD MODE REGISTER command, AR = AUTO REFRESH command, ACT = ACTIVE command, RA = Row Address, BA = Bank Address
3. The Load Mode Register for both MR/EMR and 2 Auto Refresh commands can be in any order; However, all must occur prior to an Active command.
4. NOP or DESELECT commands are required for at least 200 $\mu$ s.
5. Other valid commands are possible.
6. NOPs or DESELECTs are required during this time.



## Register Definition

### Mode Registers

The mode registers are used to define the specific mode of operation of the Low Power DDR SDRAM. There are two mode registers used to specify the operational characteristics of the device. The standard mode register, which exists for all Low Power DDR SDRAM devices, and the extended mode register, which exists on all Low Power DDR SDRAM devices.

### Standard Mode Register

The standard mode register definition includes the selection of a burst length, a burst type, a CAS latency and an operating mode, as shown in Table 1 on page 10. The standard mode register is programmed via the LOAD MODE REGISTER SET command (with BA0 = 0 and BA1 = 0) and will retain the stored information until it is programmed again. Reprogramming the standard mode register will not alter the contents of the memory, provided it is performed correctly. The mode register must be loaded (reloaded) when all banks are idle and no bursts are in progress, and the controller must wait the specified time before initiating the subsequent operation. Violating either of these requirements will result in unspecified operation.

Mode register bits A0–A2 specify the burst length, A3 specifies the type of burst (sequential or interleaved), A4–A6 specify the CAS latency, and A7–A13 specify the operating mode.

**Note:** Standard refers to meeting JEDEC-standard mode register definitions.

### Burst Length

Read and write accesses to the Low Power DDR SDRAM are burst oriented, with the burst length being programmable, as shown in Table 1 on page 10. The burst length determines the maximum number of column locations that can be accessed for a given READ or WRITE command. Burst lengths of 2,4,8 or 16 are available for both the sequential and the interleaved burst types.

Reserved states should not be used, as unknown operation or incompatibility with future versions may result. When a READ or WRITE command is issued, a block of columns equal to the burst length is effectively selected. All accesses for that burst take place within this block, meaning that the burst will wrap until a boundary is reached. The block is uniquely selected by A1–Ai when BL = 2, by A2–Ai when BL = 4, by A3–Ai when BL = 8, by A4–Ai when BL=16 (where Ai is the most significant column address bit for a given configuration). The remaining (least significant) address bit(s) is (are) used to select the starting location within the block.

The programmed burst length applies to both READ and WRITE bursts.

### Burst Type

Accesses within a given burst may be programmed to be either sequential or interleaved; this is referred to as the burst type and is selected via bit M3.

The ordering of accesses within a burst is determined by the burst length, the burst type and the starting column address. See Table 2 on page 11 for more information.

**READ Latency**

The READ latency is the delay, in clock cycles, between the registration of a READ command and the availability of the first bit of output data. The latency can be set to 2 or 3 clocks, as shown in Table 1 on page 10. For CL = 3, if the READ command is registered at clock edge n, then the data will nominally be available at (2 clocks + tAC). For CL = 2, if the READ command is registered at clock edge n, then the data will be nominally be available at (1 clock + tAC).

Reserved states should not be used as unknown operation or incompatibility with future versions may result.

**Table 1: Standard Mode Register Definition**

M15-BA1	M14-BA0	M13-A13	M12-A12	M11-A11	M10-A10	M9-A9	M8-A8	M7-A7	M6-A6	M5-A5	M4-A4	M3-A3	M2-A2	M1-A1	M0-A0
0	0	Operation Mode						CAS Latency			BT	Burst Length			

M15	M14	Mode Register Definition
0	0	Standard Mode Register
0	1	Status Read Register
1	0	Extended Mode Register
1	1	Reserved

M6	M5	M4	CAS Latency
0	0	0	Reserved
0	0	1	Reserved
0	1	0	2
0	1	1	3
1	0	0	Reserved
1	0	1	Reserved
1	1	0	Reserved
1	1	1	Reserved

M2	M1	M0	Burst Length
0	0	0	Reserved
0	0	1	2
0	1	0	4
0	1	1	8
1	0	0	16
1	0	1	Reserved
1	1	0	Reserved
1	1	1	Reserved

M13	M12	M11	M10	M9	M8	M7		Operating Mode
0	0	0	0	0	0	0	Valid	Normal Operation
-	-	-	-	-	-	-	-	All other states reserved

M3	Burst Type
0	Sequential
1	Interleaved

**Table 2: Burst Definition**

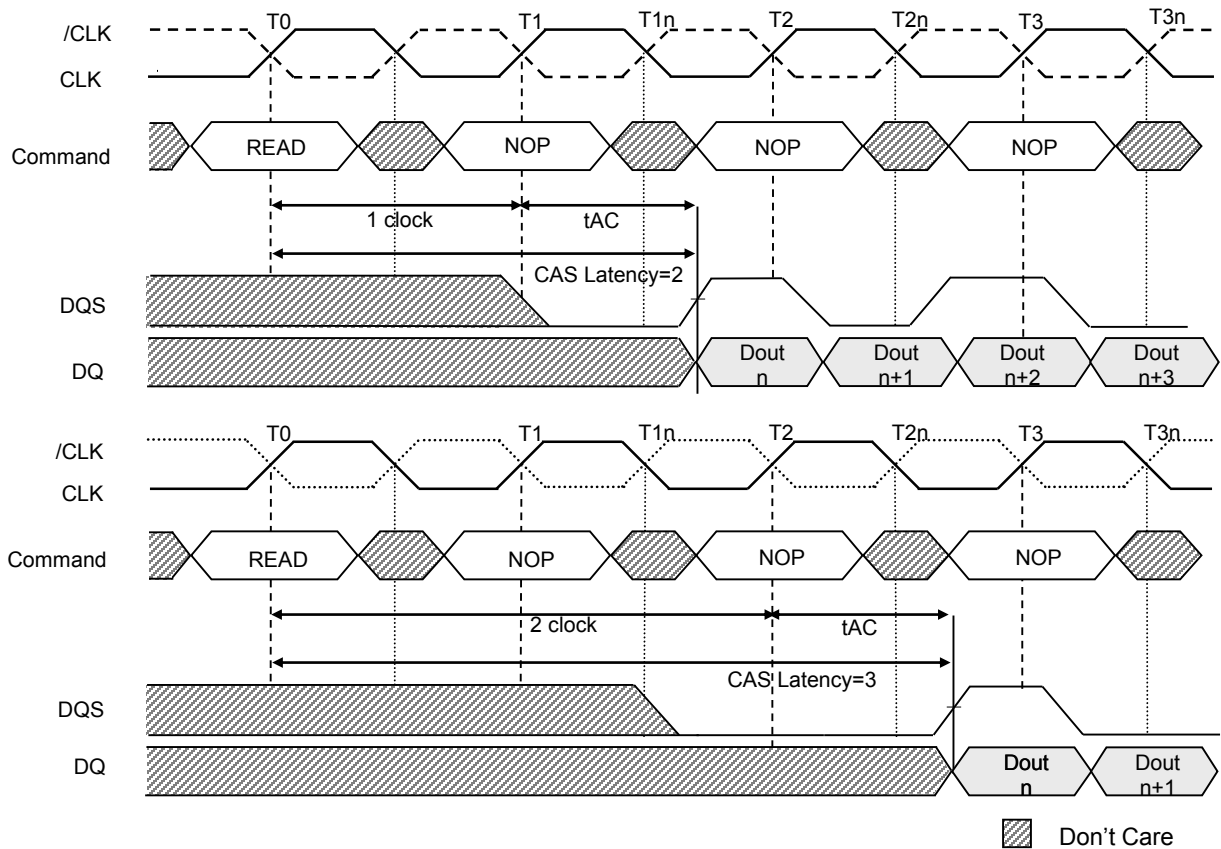
Burst Length	Starting Column Address				Order of Accesses Within a Burst	
					Type = Sequential	Type = Interleaved
2	A0					
	0				0-1	0-1
	1				1-0	1-0
4	A1 A0					
	0 0				0-1-2-3	0-1-2-3
	0 1				1-2-3-0	1-0-3-2
	1 0				2-3-0-1	2-3-0-1
	1 1				3-0-1-2	3-2-1-0
8	A2 A1 A0					
	0 0 0				0-1-2-3-4-5-6-7	0-1-2-3-4-5-6-7
	0 0 1				1-2-3-4-5-6-7-0	1-0-3-2-5-4-7-6
	0 1 0				2-3-4-5-6-7-0-1	2-3-0-1-6-7-4-5
	0 1 1				3-4-5-6-7-0-1-2	3-2-1-0-7-6-5-4
	1 0 0				4-5-6-7-0-1-2-3	4-5-6-7-0-1-2-3
	1 0 1				5-6-7-0-1-2-3-4	5-4-7-6-1-0-3-2
	1 1 0				6-7-0-1-2-3-4-5	6-7-4-5-2-3-0-1
16	A3 A2 A1 A0					
	0 0 0 0				0-1-2-3-4-5-6-7-8-9-10-11-12-13-14-15	0-1-2-3-4-5-6-7-8-9-10-11-12-13-14-15
	0 0 0 1				1-2-3-4-5-6-7-8-9-10-11-12-13-14-15-0	1-0-3-2-5-4-7-6-9-8-11-10-13-12-15-14
	0 0 1 0				2-3-4-5-6-7-8-9-10-11-12-13-14-15-0-1	2-3-0-1-6-7-4-5-10-11-8-9-14-15-12-13
	0 0 1 1				3-4-5-6-7-8-9-10-11-12-13-14-15-0-1-2	3-2-1-0-7-6-5-4-11-10-9-8-15-14-13-12
	0 1 0 0				4-5-6-7-8-9-10-11-12-13-14-15-0-1-2-3	4-5-6-7-0-1-2-3-12-13-14-15-8-9-10-11
	0 1 0 1				5-6-7-8-9-10-11-12-13-14-15-0-1-2-3-4	5-4-7-6-1-0-3-2-13-12-15-14-9-8-11-10
	0 1 1 0				6-7-8-9-10-11-12-13-14-15-0-1-2-3-4-5	6-7-4-5-2-3-0-1-14-15-12-13-10-11-8-9
	0 1 1 1				7-8-9-10-11-12-13-14-15-0-1-2-3-4-5-6	7-6-5-4-3-2-1-0-15-14-13-12-11-10-9-8
	1 0 0 0				8-9-10-11-12-13-14-15-0-1-2-3-4-5-6-7	8-9-10-11-12-13-14-15-0-1-2-3-4-5-6-7
	1 0 0 1				9-10-11-12-13-14-15-0-1-2-3-4-5-6-7-8	9-8-11-10-13-12-15-14-1-0-3-2-5-4-7-6
	1 0 1 0				10-11-12-13-14-15-0-1-2-3-4-5-6-7-8-9	10-11-8-9-14-15-12-13-2-3-0-1-6-7-4-5
	1 0 1 1				11-12-13-14-15-0-1-2-3-4-5-6-7-8-9-10	11-10-9-8-15-14-13-12-3-2-1-0-7-6-5-4
	1 1 0 0				12-13-14-15-0-1-2-3-4-5-6-7-8-9-10-11	12-13-14-15-8-9-10-11-4-5-6-7-0-1-2-3
1 1 0 1				13-14-15-0-1-2-3-4-5-6-7-8-9-10-11-12	13-12-15-14-9-8-11-10-5-4-7-6-1-0-3-2	
1 1 1 0				14-15-0-1-2-3-4-5-6-7-8-9-10-11-12-13	14-15-12-13-10-11-8-9-6-7-4-5-2-3-0-1	
1 1 1 1				15-0-1-2-3-4-5-6-7-8-9-10-11-12-13-14	15-14-13-12-11-10-9-8-7-6-5-4-3-2-1-0	

**Notes:**

- For BL = 2, A1–Ai select the two-data-element block; A0 selects the first access within the block.
- For BL = 4, A2–Ai select the four-data-element block; A0–A1 select the first access within the block.
- For BL = 8, A3–Ai select the eight-data-element block; A0–A2 select the first access within the block.
- For BL=16, A4–Ai select the sixteen-data-element block; A0–A3 select the first access within the block.
- Whenever a boundary of the block is reached within a given sequence above, the following access wraps within the block.
- Ai = the most significant column address bit for a given configuration.

**Table 3: CAS Latency**

Speed	Allowable Operating Clock Frequency (MHz)	
	CL = 2	CL = 3
-5	f ≤83	f ≤200

**Figure 2: CAS Latency**

**Notes:**

1. BL = 4 in the cases shown.
2. Shown with nominal t<sub>AC</sub> and nominal t<sub>DQSCLK</sub>.

**Operating Mode**

The normal operating mode is selected by issuing a LOAD MODE REGISTER SET command with bits A7–A13 each set to zero, and bits A0–A6 set to the desired values. All other combinations of values for A7–A13 are reserved for future use and/or test modes. Test modes and reserved states should not be used because unknown operation or incompatibility with future versions may result.

**Extended Mode Register**

The extended mode register controls functions specific to low power operation. These additional functions include drive strength, temperature compensated self refresh, and partial array self refresh. This device has default values for the extended mode register (if not programmed, the device will operate with the default values – PASR = Full Array, DS = Full Drive).

**Temperature Compensated Self Refresh**

A temperature sensor is implemented for automatic control of the self refresh oscillator on the device. Programming of the temperature compensated self refresh (TCSR) bits will have no effect on the device. The self refresh oscillator will continue refresh at the factory programmed optimal rate for the device temperature.

### Partial Array Self Refresh

For further power savings during SELF REFRESH, the PASR feature allows the controller to select the amount of memory that will be refreshed during SELF REFRESH. The refresh options are as follows:

- Full array: banks 0, 1, 2, and 3
- Half array: banks 0 & 1
- Quarter array: bank 0
- One Eighth array: Half of Bank0
- One Sixteenth array: Quarter of Bank0

WRITE and READ commands can still occur during standard operation, but only the selected banks will be refreshed during SELF REFRESH. Data in banks that are disabled will be lost.

### Output Driver Strength

Because the Low Power DDR SDRAM is designed for use in smaller systems that are mostly point to point, an option to control the drive strength of the output buffers is available. Drive strength should be selected based on the expected loading of the memory bus. Bits A5 ~ A7 of the extended mode register can be used to select the driver strength of the DQ outputs. There are five allowable settings for the output drivers.

**Table 4: Extended Mode Register Table[1.2].**

EM15- BA1	EM14- BA0	EM13- A13	EM12- A12	EM11- A11	EM10- A10	EM9- A9	EM8- A8	EM7- A7	EM6- A6	EM5- A5	EM4- A4	EM3- A3	EM2- A2	EM1- A1	EM0- A0
1	0	All must be set to '0'						Driver Strength		0	0	PASR			

EM15	EM14	Mode Register Definition
0	0	Standard Mode Register
0	1	Status Read Register
1	0	<b>Extended Mode Register</b>
1	1	Reserved

A2	A1	A0	Self Refresh Coverage
0	0	0	All Banks
0	0	1	Half of Total Bank(BA1=0)
0	1	0	Quarter of Total Bank(BA1=BA0=0)
0	1	1	RFU
1	0	0	RFU
1	0	1	One Eighth of Total Bank (BA1=BA0=Row Address MSB=0 )
1	1	0	One Sixteenth of Total Bank (BA1=BA0=Row Address2 MSBs=0)
1	1	1	RFU

A7	A6	A5	Driver Strength
0	0	0	100%
0	0	1	50%
0	1	0	25%
0	1	1	12.5%
1	0	0	75%
1	0	1	Reserved
1	1	0	Reserved
1	1	1	Reserved

**Note :**

1. EM15 and EM14 (BA1 and BA0) must be "1, 0" to select the Extended Mode Register(vs. the base Mode Register).
2. RFU: Reserved for Future Use

**Status Read Registers**

The status read register (SRR) is used to read the manufacturer ID, revision ID, refresh multiplier, width type, and density of the device, as shown in Table 5 (page 14). The SRR is read via the LOAD MODE REGISTER command with BA0 = 1 and BA1 = 0. The sequence to perform an SRR command is as follows:

- The device must be properly initialized and in the idle or all banks precharged state.
- Issue a LOAD MODE REGISTER command with BA[1:0] = 01 and all address pins set to 0.
- Wait tSRR; only NOP or DESELECT commands are supported during the tSRR time.
- Issue a READ command.
- Subsequent commands to the device must be issued tSRC after the SRR READ command is issued; only NOP or DESELECT commands are supported during tSRC.

SRR output is read with a burst length of 2. SRR data is driven to the outputs on the first bit of the burst, with the output being “Don’t Care” on the second bit of the burst.

**Table 5: Status Register Table.**

S31~S16 <sup>1</sup>	S15	S14	S13	S12	S11	S10	S9	S8	S7	S6	S5	S4	S3	S2	S1	S0
Reserved		Density			Type	Width	Refresh Rate			Revision ID			Manufacturer ID			

S15	S14	S13	Density
0	0	0	128Mb
0	0	1	256Mb
0	1	0	512Mb
0	1	1	Reserved
1	0	0	Reserved
1	0	1	Reserved
1	1	0	Reserved
1	1	1	Reserved

S12	Device Type
0	LPDDR
1	Reserve

S11	Device Width
0	16 bits
1	32 bits

S3	S2	S1	S0	Manufacturer ID
0	0	0	0	Alliance Memory
0	0	0	1	Reserved
0	0	1	0	Reserved
0	0	1	1	Reserved
0	1	0	0	Reserved
0	1	0	1	Reserved
0	1	1	0	Reserved
0	1	1	1	Reserved
1	0	0	0	Reserved
1	0	0	1	Reserved
1	0	1	0	Reserved
1	0	1	1	Reserved
1	1	0	0	Reserved
1	1	0	1	Reserved
1	1	1	0	Reserved
1	1	1	1	Reserved

S10	S9	S8	Refresh Multiplier <sup>2</sup>
0	0	0	Reserved
0	0	1	Reserved
0	1	0	Reserved
0	1	1	2X
1	0	0	1X
1	0	1	Reserved
1	1	0	0.25X
1	1	1	Reserved

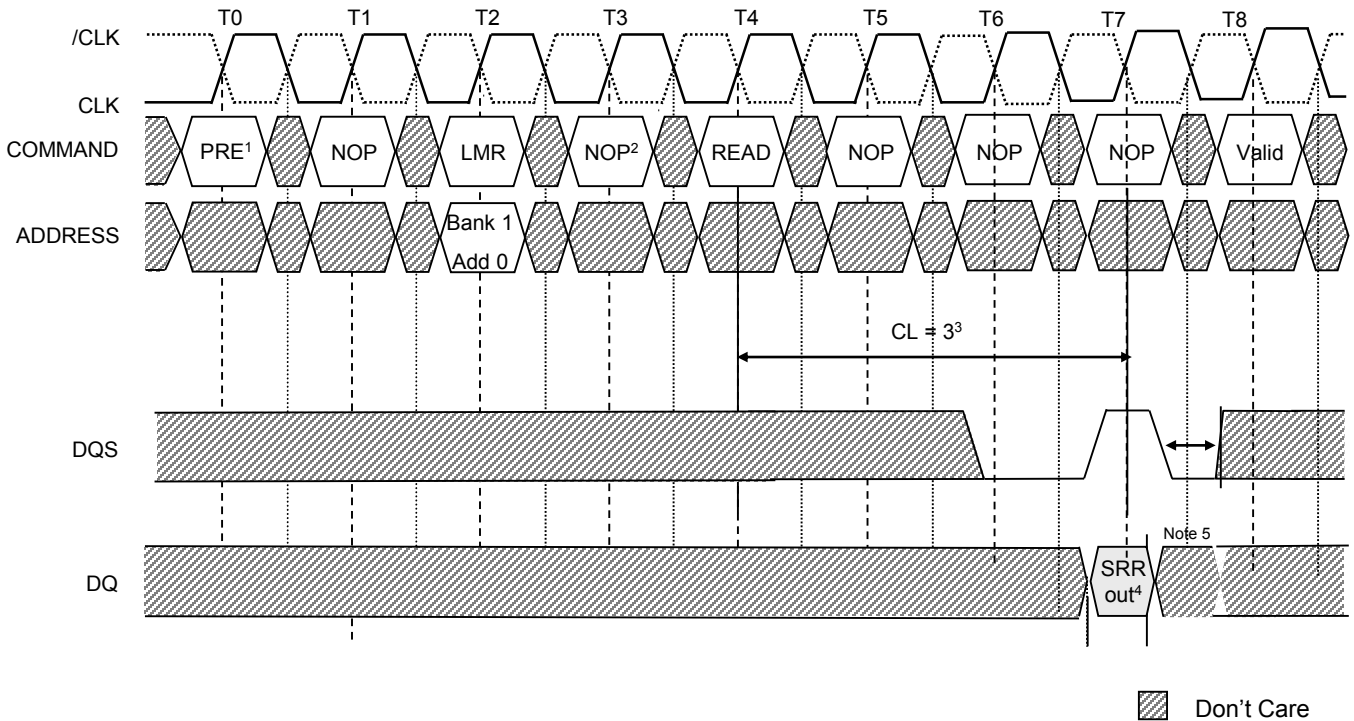
S7	S6	S5	S4	Revision ID
0	0	0	0	The manufacturer's revision number starts at '0000' and increments by '0001' each time a change in the specification (AC timings or feature set), IBIS (pull-up or pull-down characteristics), or process occurs.
~				
1	1	1	1	

Note : 1. Reserved bits should be set to 0 for future compatibility.

2. Refresh multiplier is based on the device on-board temperature sensor.

Required periodic refresh interval = tREFI X multiplier.

Self refresh is not supported for automotive device at high temperature. (85°C to 105°C)

**Figure 3: Status Read Register Timing**


Note : 1. All banks must be idle prior to status register read.

2. NOP or DESELECT commands are required between the LMR and READ commands (tSRR), and between the READ and the next VALID command (tSRC).

3. CAS latency is predetermined by the programming of the mode register. CL = 3 is shown as an example only.

4. Burst length is fixed to 2 for SRR regardless of the value programmed by the mode register.

5. The second bit of the data-out burst is a "Don't Care."

### Stopping the External Clock

One method of controlling the power efficiency in applications is to throttle the clock which controls the Low Power DDR SDRAM. There are two basic ways to control the clock:

1. Change the clock frequency, when the data transfers require a different rate of speed.
2. Stopping the clock altogether.

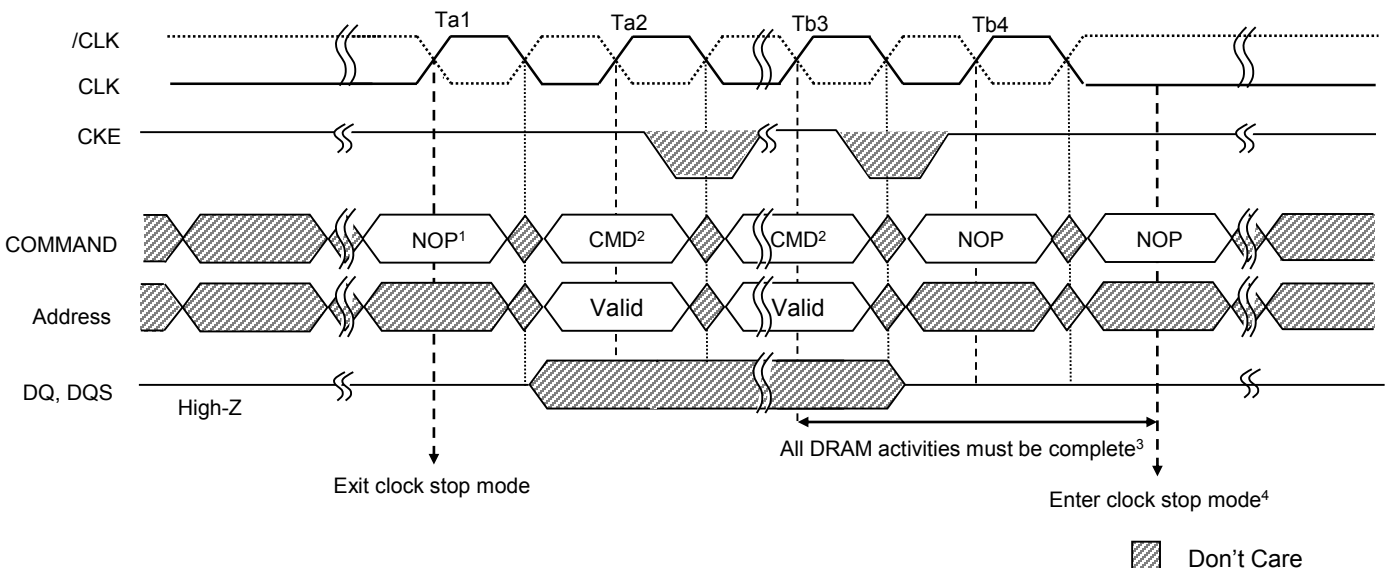
Both of these are specific to the application and its requirements and both allow power savings due to possible less transitions on the clock path.

The Low Power DDR SDRAM allows the clock to change frequency during operation, only if all the timing parameters are met with respect to that change and all refresh requirements are satisfied.

The clock can also be stopped all together, if there are no data accesses in progress, either WRITES or READs that would be effected by this change; i.e., if a WRITE or a READ is in progress the entire data burst must be through the pipeline prior to stopping the clock. CKE must be held HIGH with CLK = LOW and /CLK = HIGH for the full duration of the clock stop mode. One clock cycle and at least one NOP is required after the clock is restarted before a valid command can be issued. Figure 4 on page 16 illustrates the clock stop mode.

It is recommended that the Low Power DDR SDRAM should be in a precharged state if any changes to the clock frequency are expected. This will eliminate timing violations that may otherwise occur during normal operational accesses.

**Figure 4: Clock Stop Mode**



**Notes:**

1. Prior to Ta1 the device is in clock stop mode. To exit, at least one NOP is required before any valid command.
2. Any valid command is allowed, device is not in clock suspend mode.
3. Any DRAM operation already in process must be completed before entering clock stop mode. This includes tRCD, tRP, tRFC, tMRD, tWR, all data-out for READ bursts. This means the DRAM must be either in the idle or precharge state before clock suspend mode can be entered.
4. To enter and maintain a clock stop mode: CLK = LOW, /CLK = HIGH, CKE = HIGH.



## Commands

Table 6 and Table 7 provide quick references of available commands. This is followed by a written description of each command. Three additional Truth Tables (Table 13 on page 46, Table 14 on page 47, and Table 15 on page 49) provide CKE commands and current/ next state information.

**Table 6: Truth Table – Commands**

Notes : 1 and 11 apply to all commands

Name (Function)	/CS	/RAS	/CAS	/WE	ADDR	Notes
DESELECT (NOP)	H	X	X	X	X	9
NO OPERATION (NOP)	L	H	H	H	X	9
ACTIVE (select bank and activate row)	L	L	H	H	Bank/Row	3
READ (Select bank and column, and start READ burst)	L	H	L	H	Bank/Col	4
WRITE (Select bank and column, and start WRITE burst)	L	H	L	L	Bank/Col	4
BURST TERMINATE	L	H	H	L	X	8, 10
PRECHARGE (deactivate row in bank or banks)	L	L	H	L	Code	5
AUTO REFRESH (refresh all or single bank) or SELF REFRESH (enter self refresh mode)	L	L	L	H	X	6, 7
LOAD MODE REGISTER (standard or extended mode registers)	L	L	L	L	Op-Code2	2
Deep Power Down( Enter DPD Mode )	L	H	H	L	Op-Code2	11

**Notes:**

1. CKE is HIGH for all commands shown except SELF REFRESH and Deep Power Down.
2. BA0–BA1 select either the standard mode register or the extended mode register (BA0 = 0, BA1 = 0 select the standard mode register; BA0 = 0, BA1 = 1 select extended mode register; other combinations of BA0–BA1 are reserved). A0–A13 provide the op- code to be written to the selected mode register.
3. BA0–BA1 provide bank address and A0–A13 provide row address.
4. BA0–BA1 provide bank address; A0–A9 provide column address; A10 HIGH enables the auto precharge feature ( nonpersistent ), and A10 LOW disables the auto precharge feature.
5. A10 LOW : BA0–BA1 determine which bank is precharged. A10 HIGH: all banks are precharged and BA0–BA1 are “Don’t Care.”
6. This command is AUTO REFRESH if CKE is HIGH, SELF REFRESH if CKE is LOW.
7. Internal refresh counter controls row addressing; all inputs and I/Os are “Don’t Care” except for CKE.
8. Applies only to read bursts with auto precharge disabled; this command is undefined (and should not be used) for READ bursts with auto precharge enabled and for WRITE bursts.
9. Deselect and NOP are functionally interchangeable.
10. This command is a BURST TERMINATE if CKE is HIGH.
11. This command is a Deep Power Down if CKE is Low.
12. All states and sequences not shown are reserved and/or illegal.

**Table 7: Truth Table – DM Operation**

Name (Function)	DM	DQ
Write enable	L	Valid
Write inhibit	H	X

Note: Used to mask write data; provided coincident with corresponding data.

### DESELECT

The Deselect function (/CS HIGH) prevents new commands from being executed by the Low Power DDR SDRAM. The Low Power DDR SDRAM is effectively deselected. Operations already in progress are not affected.

### NO OPERATION (NOP)

The NO OPERATION (NOP) command is used to instruct the selected DDR SDRAM to perform a NOP (/CS = LOW, /RAS = /CAS = /WE = HIGH). This prevents unwanted commands from being registered during idle or wait states. Operations already in progress are not affected.

## LOAD MODE REGISTER

The mode registers are loaded via inputs A0–A13. See mode register descriptions in “Register Definition” on page 9. The LOAD MODE REGISTER command can only be issued when all banks are idle, and a subsequent executable command cannot be issued until tMRD is met.

## ACTIVE

The ACTIVE command is used to open (or activate) a row in a particular bank for a subsequent access. The value on the BA0, BA1 inputs selects the bank, and the address provided on inputs A0–A13 selects the row. This row remains active (or open) for accesses until a PRECHARGE command is issued to that bank. A PRECHARGE command must be issued before opening a different row in the same bank.

## READ

The READ command is used to initiate a burst read access to an active row. The value on the BA0, BA1 inputs selects the bank, and the address provided on inputs A0–A9 selects the starting column location. The value on input A10 determines whether or not auto precharge is used. If auto precharge is selected, the row being accessed will be precharged at the end of the READ burst; if auto precharge is not selected, the row will remain open for subsequent accesses.

## WRITE

The WRITE command is used to initiate a burst write access to an active row. The value on the BA0, BA1 inputs selects the bank, and the address provided on inputs A0–A9 selects the starting column location. The value on input A10 determines whether or not auto precharge is used. If auto precharge is selected, the row being accessed will be precharged at the end of the WRITE burst; if auto precharge is not selected, the row will remain open for subsequent accesses. Input data appearing on the DQs is written to the memory array subject to the DM input logic level appearing coincident with the data. If a given DM signal is registered LOW, the corresponding data will be written to memory; if the DM signal is registered HIGH, the corresponding data inputs will be ignored, and a WRITE will not be executed to that byte/column location.

## PRECHARGE

The PRECHARGE command is used to deactivate the open row in a particular bank or the open row in all banks. The bank(s) will be available for a subsequent row access a specified time (tRP) after the precharge command is issued. Except in the case of concurrent auto precharge, where a READ or WRITE command to a different bank is allowed as long as it does not interrupt the data transfer in the current bank and does not violate any other timing parameters. Input A10 determines whether one or all banks are to be precharged, and in the case where only one bank is to be precharged, inputs BA0, BA1 select the bank. Otherwise BA0, BA1 are treated as “Don’t Care.” Once a bank has been precharged, it is in the idle state and must be activated prior to any READ or WRITE commands being issued to that bank. A PRECHARGE command will be treated as a NOP if there is no open row in that bank (idle state), or if the previously open row is already in the process of precharging.

### **Auto Precharge**

Auto precharge is a feature which performs the same individual-bank precharge function described above, but without requiring an explicit command. This is accomplished by using A10 to enable auto precharge in conjunction with a specific READ or WRITE command. A precharge of the bank/row that is addressed with the READ or WRITE command is automatically performed upon completion of the READ or WRITE burst. Auto precharge is nonpersistent in that it is either enabled or disabled for each individual READ or WRITE command. This device supports concurrent auto precharge if the command to the other bank does not interrupt the data transfer to the current bank.

Auto precharge ensures that the precharge is initiated at the earliest valid stage within a burst. This “earliest valid stage” is determined as if an explicit PRECHARGE command was issued at the earliest possible time, without violating tRAS (MIN), as described for each burst type in “Operations” on page 24. The user must not issue another command to the same bank until the precharge time (tRP) is completed.

### **BURST TERMINATE**

The BURST TERMINATE command is used to truncate READ bursts (with auto precharge disabled). The most recently registered READ command prior to the BURST TERMINATE command will be truncated, as shown in “Operations” on page 24. The open page which the READ burst was terminated from remains open.

### **AUTO REFRESH**

AUTO REFRESH is used during normal operation of the Low Power DDR SDRAM and is analogous to /CAS-BEFORE-/RAS (CBR) REFRESH in FPM/EDO DRAMs. This command is nonpersistent, so it must be issued each time a refresh is required.

The addressing is generated by the internal refresh controller. This makes the address bits a “Don’t Care” during an AUTO REFRESH command. The 512Mb Low Power DDR SDRAM requires AUTO REFRESH cycles at an average interval of 7.8125 $\mu$ s (maximum). To allow for improved efficiency in scheduling and switching between tasks, some flexibility in the absolute refresh interval is provided.

Although not a JEDEC requirement, to provide for future functionality features, CKE must be active (HIGH) during the auto refresh period. The auto refresh period begins when the AUTO REFRESH command is registered and ends tRFC later.

### **SELF REFRESH**

The SELF REFRESH command can be used to retain data in the Low Power DDR SDRAM, even if the rest of the system is powered down. When in the self refresh mode, the Low Power DDR SDRAM retains data without external clocking. The SELF REFRESH command is initiated like an AUTO REFRESH command except CKE is disabled (LOW). All command and address input signals except CKE are “Don’t Care” during SELF REFRESH.

During SELF REFRESH, the device is refreshed as identified in the external mode register (see PASR setting). For a the full array refresh, all four banks are refreshed simultaneously with the refresh frequency set by an internal self refresh oscillator. This oscillator changes due to the temperature sensors input. As the case temperature of the Low Power DDR SDRAM increases, the oscillation frequency will change to accommodate the change of temperature. This happens because the DRAM capacitors lose charge faster at higher temperatures. To ensure efficient power dissipation during self refresh, the oscillator will change to refresh at the slowest rate possible to maintain the devices data.

The procedure for exiting SELF REFRESH requires a sequence of commands. First, CLK must be stable prior to CKE going back HIGH. Once CKE is HIGH, the Low Power DDR SDRAM must have NOP commands issued for tXSR is required for the completion of any internal refresh in progress. Self refresh is not supported for automotive device at high temperature.(85°C to 105°C)

### **DEEP POWER DOWN**

Deep Power Down Mode is an operating mode to achieve extreme power reduction by cutting the power of the whole memory array of the device. Data will not be retained once the device enters DPD Mode. Full initialization is required when the device exits from DPD Mode. [Figure 38,39]

### Maximum Ratings

Voltage on $V_{DD}/V_{DDQ}$ Supply	
Relative to $V_{SS}$ .....	-0.5V to + 2.3V
Voltage on Inputs, NC or I/O Pins	
Relative to $V_{SS}$ .....	-0.5V to +2.3V
Storage Temperature (plastic) .....	-55°C to + 150°C
Power Dissipation .....	1W

\*Stresses greater than those listed under "Maximum Ratings" may cause permanent damage to the device. This is a stress rating only, and functional operation of the device at these or any other conditions above those indicated in the operational sections of this specification is not implied. Exposure to absolute maximum rating conditions for extended periods may affect reliability.

### Operating Range

Device	Range	Ambient Temperature	$V_{DD}$	$V_{DDQ}$
AS4C64M16MD1A-5BIN	Industrial	-40°C to +85°C	1.7V ~ 1.95V	1.7V ~ $V_{DD}$

### DC ELECTRICAL CHARACTERISTICS AND OPERATING CONDITIONS <sup>[1,2]</sup>

Parameter / Condition	Symbol	Min	Max	Units
Supply Voltage	$V_{DD}$	1.7	1.95	V
I/O Supply Voltage	$V_{DDQ}$	1.7	$V_{DD}$	V
Clock Input Voltage : CK, CK# <sup>[7]</sup>	$V_{IN}$	-0.3	$V_{DDQ} + 0.3$	V
Clock Input Differential Voltage : CK, CK# <sup>[7,8]</sup>	$V_{ID}$	$0.4 * V_{DDQ}$	$V_{DDQ} + 0.6$	V
Input High Voltage : Logic 1 Address, Command and Data Input <sup>[3]</sup>	$V_{IH}$	$0.7 * V_{DDQ}$	$V_{DDQ} + 0.3$	V
Input Low Voltage : Logic 0 Address, Command and Data Inputs <sup>[3]</sup>	$V_{IL}$	-0.3	$0.3 * V_{DDQ}$	V
Data Output High Voltage : Logic 1 : All Inputs(-0.1mA)	$V_{OH}$	$0.9 * V_{DDQ}$		V
Data Output Low Voltage : Logic 0 : All Inputs(0.1mA)	$V_{OL}$		$0.1 * V_{DDQ}$	V
Input Leakage Current : Any Input 0V= $V_{IN}=V_{DD}$ (All other pins not under test=0V)	I <sub>I</sub>	-5	5	μA
Output Leakage Current : DQs are disabled ; 0V= $V_{OUT}=V_{DDQ}$	I <sub>OZ</sub>	-5	5	μA

**Table 8. AC Operating Conditions**<sup>[1,2,3,4,5,6]</sup>

Parameter / Condition	Value	Units
AC Address, Command and Data Input levels (Vih / Vil)	$0.8 * V_{DDQ} / 0.2 * V_{DDQ}$	V
Clock Input Differential Level( $V_{ID}$ ) : CK, CK# <sup>[7,8]</sup>	$0.6 * V_{DDQ} \sim V_{DDQ} + 0.6$	V
Clock Differential Crossing Level( $V_{IX}$ ) : CK, CK# <sup>[7,9]</sup>	$0.4 * V_{DDQ} \sim 0.6 * V_{DDQ}$	V
Input Timing Measurement Reference Level	$0.5 * V_{DDQ}$	V
Input Signal Minimum Slew Rate	1.0	V/ns
Output Timing Measurement Reference Level	$0.5 * V_{DDQ}$	V
Output Load Condition	AC Output Load Circuit on page 20	V

**Note :**

- The minimum specifications are used only to indicate cycle time at which proper operation over the full temperature range ( $-40^{\circ}\text{C} \leq T_A \leq +85^{\circ}\text{C}$  for IT parts) is ensured.
- An initial pause of 200 $\mu\text{s}$  is required after power-up, followed by two AUTO REFRESH commands, before proper device operation is ensured. ( $V_{DD}$  and  $V_{DDQ}$  must be powered up simultaneously.  $V_{SS}$  and  $V_{SSQ}$  must be at same potential.) The two AUTO REFRESH command wake-ups should be repeated any time the  $t_{REF}$  refresh requirement is exceeded.
3. All states and sequences not shown are illegal or reserved.
- In addition to meeting the transition rate specification, the clock and CKE must transit between  $V_{IH}$  and  $V_{IL}$  (or between  $V_{IL}$  and  $V_{IH}$ ) in a monotonic manner.
- $t_{HZ}$  defines the time at which the output achieves the open circuit condition; it is not a reference to  $V_{OH}$  or  $V_{OL}$ . The last valid data element will meet  $t_{OH}$  before going High-Z.
- AC timing and  $I_{DD}$  tests have  $V_{IL}$  and  $V_{IH}$ , with timing referenced to  $V_{IH}/2 =$  crossover point. If the input transition time is longer than  $t_T$  (MAX), then the timing is referenced at  $V_{IL}$  (MAX) and  $V_{IH}$  (MIN) and no longer at the  $V_{IH}/2$  crossover point.
- CK and CK# input slew rate must be  $\geq 1$  V/ns (2 V/ns if measured differentially).
- $V_{ID}$  is the magnitude of the difference between the input level on CK and the input level on CK#.
- The value of  $V_{IX}$  is expected to equal  $V_{DDQ}/2$  of the transmitting device and must track variations in the DC level of the same.

**Table 9: IDD Specifications and Conditions**

Parameter/Condition	Symbol	Max	Units	Notes	
		-5			
Operating one bank active precharge current: tRC = tRC(MIN); tCLK = tCLK(MIN); CKE is HIGH; CS is HIGH between valid commands; Address inputs are switching every two CLK cycles; Data bus inputs are stable.	IDD0	95	mA	1, 6	
Precharge power-down standby current: All banks idle; CKE is LOW; CS is HIGH; tCLK = tCLK(MIN); Address and control inputs are switching every two CLK cycles; Data bus inputs are stable.	IDD2P	600	μA	2, 4	
Precharge power-down standby current with CLK stopped: All banks idle; CKE is LOW, CS is HIGH; CLK = LOW, /CLK = HIGH; Address and control inputs are switching every two CLK cycles; Data bus inputs are stable.	IDD2PS	600	μA	2, 4	
Precharge non power-down standby current: All banks idle; CKE = HIGH; CS = HIGH; tCLK = tCLK(MIN); Address and control inputs are switching every two CLK cycles; Data bus inputs are stable.	IDD2N	18	mA	5	
Precharge non power-down standby current: CLK stopped; All banks idle; CKE = HIGH; CS = HIGH; CLK = LOW; /CLK = HIGH Address and control inputs are switching every two CLK cycles; Data bus inputs are stable.	IDD2NS	14	mA	5	
Active power-down standby current: One bank active; CKE = LOW; CS = HIGH; tCLK = tCLK(MIN); Address and control inputs are switching every two CLK cycles; Data bus inputs are stable.	IDD3P	3.6	mA	2, 4	
Active power-down standby current: CLK stopped; One bank active; CKE = LOW; CS = HIGH; CLK = LOW; /CLK = HIGH; Address and control inputs are switching every two CLK cycles; Data bus inputs are stable.	IDD3PS	3.6	mA	2, 4	
Active non power-down standby: One bank active; CKE = HIGH; CS = HIGH; tCLK = tCLK(MIN); Address and control inputs are switching every two cycles; Data bus inputs are stable.	IDD3N	20	mA	1	
Active non-power-down standby: CLK stopped; One bank active; CKE = HIGH; CS = HIGH; CLK = LOW; /CLK = HIGH; Address and control inputs are switching every two CLK cycles; Data bus inputs are stable.	IDD3NS	14	mA	1	
Operating burst read : One bank active; BL = 4; tCLK = tCLK(MIN); Continuous READ bursts; Address inputs are switching; 50 percent data changing each burst.	IDD4R	135	mA	1, 6	
Operating burst write: One bank active; BL = 4; tCLK = tCLK(MIN); Continuous WRITE bursts; Address inputs are switching; 50 percent data changing each burst.	IDD4W	135	mA	1, 6	
Auto refresh: Burst refresh; CKE = HIGH; Address and control inputs are switching; Data bus inputs are stable.	tRC = tRFC(138ns)	IDD5	100	mA	7
	tRC = 7.8125μs	IDD5a	15	mA	3, 7
Self refresh: CKE = LOW; tCLK = tCLK(MIN); Address and control inputs are stable; Data bus inputs are Stable.	Full Array, 85°C	IDD6a	1300	μA	8, 9
	Full Array, 45°C	IDD6a	450	μA	8, 9
	Half Array, 85°C	IDD6b	1000	μA	8, 9
	¼ Array, 85°C	IDD6c	900	μA	8, 9
Deep Power Down Current ; Address, control and data bus inputs are STABLE	IDD7	15	μA	10	

**Notes :**

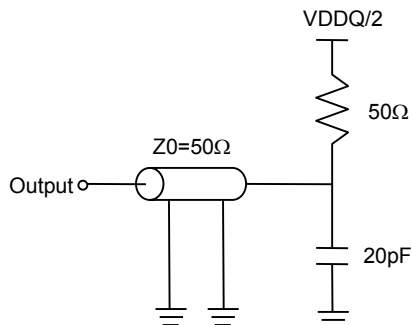
- MIN (tRC or tRFC) for IDD measurements is the smallest multiple of tCLK that meets the minimum absolute value for the respective parameter. tRAS (MAX) for IDD measurements is the largest multiple of tCLK that meets the maximum absolute value for tRAS.
- The refresh period equals 64ms. This equates to an average refresh rate of 7.8125μs.
- This limit is actually a nominal value and does not result in a fail value. CKE is HIGH during REFRESH command period (tRFC [MIN]) else CKE is LOW (i.e., during standby).
- DQ and DM input slew rates must not deviate from DQS by more than 10%. If the DQ/ DM/DQS slew rate is less than 0.5V/ns, timing must be derated: **50ps (pending) must be added to tDS and tDH for each 100mv/ns reduction in slew rate.** If slew rate exceeds 4V/ns, functionality is uncertain.

5. IDD2N specifies DQ, DQS, and DM to be driven to a valid HIGH or LOW logic level.
6. Switching is defined as :
  - address and command: inputs changing between HIGH and LOW once per two clock cycles;
  - data bus inputs: DQ changing between HIGH and LOW once per clock cycle; DM and DQS are STABLE.
7. CKE must be active (HIGH) during the entire time a REFRESH command is executed. That is, from the time the AUTO REFRESH command is registered, CKE must be active at each rising CLK edge, until tRFC later.
8. With the inclusion of the temperature sensor on the low-power DDR device, these numbers are shown as examples only, and will change due to the junction temperature that the device is sensing. They are expected to be maximum values at this time.
9. Enables on-chip refresh and address counters.
10. Device must be in the all banks idle state prior to entering Deep Power Down.

**Table 10: Capacitance**

Parameter	Symbol	Min	Max	Units
Input capacitance (A0-A13, BA0~BA1, CKE, /CS, /RAS, /CAS, /WE)	CIN1	1.5	3.0	pF
Input capacitance (CLK, /CLK)	CIN2	1.5	3.0	pF
Data & DQS input / output capacitance	COUT	3.0	5.0	pF
Input capacitance(DM)	CIN3	3.0	5.0	pF

### AC Output Load Circuit



**Table 11: Electrical Characteristics and Recommended AC Operating Conditions**

AC Characteristics Parameter		Symbol	-5		Units	Notes
			Min	Max		
Access window of DQ from CLK & /CLK	CL=3	tAC(3)	2.0	5.0	ns	
	CL=2	tAC(2)	2.0	6.5		
CLK high-level width		tCH	0.45	0.55	tCLK	
CLK low-level width		tCL	0.45	0.55	tCLK	
System Clock cycle time	CL=3	tCLK(3)	5	-	ns	1
	CL=2	tCLK(2)	12	-	ns	
Auto precharge write recovery + precharge time		tDAL	-	-	tCLK	16
DQ and DM input hold time relative to DQS		tDH	0.48	-	ns	9, 13, 15
DQ and DM input setup time relative to DQS		tDS	0.48	-	ns	17
DQ and DM input pulse width (for each input)		tDIPW	1.6	-	ns	
Access window of DQS from CLK & /CLK		tDQSCLK	2.0	5.0	ns	
DQS input high-pulse width		tDQSH	0.4	0.6	tCLK	
DQS input low-pulse width		tDQSL	0.4	0.6	tCLK	
Data strobe edge to Dout edge		tDQSQ	-	0.4	ns	8, 9
WRITE command to first DQS latching transition		tDQSS	0.75	1.25	tCLK	
DQS falling edge to CLK rising – setup time		tDSS	0.2	-	tCLK	
DQS falling edge from CLK rising – hold time		tDSH	0.2	-	tCLK	
Half-CLK period		tHP	tCH, tCL	-	ns	12
Data-out High-Z window from CLK & /CLK		tHZ	-	5.0	ns	3, 11
Data-out Low-Z window from CLK & /CLK		tLZ	1.0	-	ns	3, 11
Transition Time		t <sub>T</sub>	0.5	1.2	ns	
Address and control input hold time		tIH	0.9	-	ns	2, 15
Address and control input setup time		tIS	0.9	-	ns	2, 15
Address and control input pulse width		tIPW	2.2	-	ns	17
LOAD MODE REGISTER command cycle time		tMRD	2	-	tCLK	
DQ–DQS hold, DQS to first DQ to go non-valid, per access		tQH	tHP –tQHS	-	ns	8, 9
Data hold skew factor		tQHS	-	0.5	ns	
ACTIVE-to-PRECHARGE command		tRAS	42	70,000	ns	10
ACTIVE-to-ACTIVE command period		tRC	55	-	ns	
AUTO REFRESH command period		tRFC	80	-	ns	14
ACTIVE-to-READ or WRITE delay		tRCD	15	-	ns	
PRECHARGE command period		tRP	15	-	ns	
DQS read preamble	CL=3	tRPRE(3)	0.9	1.1	tCLK	11
	CL=2	tRPRE(2)	0.5	1.1	tCLK	11
DQS read postamble		tRPST	0.4	0.6	tCLK	
Read of SRR to next valid command		tSRC	CL+1	-	tCLK	
SRR to Read		tSRR	2	-	tCLK	
Internal temperature sensor valid temperature output enable		tTQ	2	-	ms	
ACTIVE bank a to ACTIVE bank b Delay		tRRD	10	-	ns	



**Table 12: Electrical Characteristics and Recommended AC Operating Conditions (continued)**

AC Characteristics Parameter	Symbol	-5		Units	Notes
		Min	Max		
DQS write preamble	tWPRE	0.25	-	tCLK	
DQS write preamble setup time	tWPRES	0	-	ns	5, 6
DQS write postamble	tWPST	0.4	0.6	tCLK	4
Write recovery time	tWR	15	-	ns	
Internal WRITE to READ command delay	tWTR	2	-	tCLK	
Average periodic refresh interval	tREFI	-	7.8	μs	7
Exit SELF REFRESH to first valid command	tXSR	120	-	ns	18
Exit power-down mode to first valid command	tPDX	25	-	ns	19
Minimum tCKE HIGH/LOW time	tCKE	1	-	tCLK	

**Notes**

- CAS latency definition: for CL = 2, the first data element is valid at (tCLK + tAC) after the CLK at which the READ command was registered; for CL = 3, the first data element is valid at (2 × tCLK + tAC) after the first CLK at which the READ command was registered.
- Fast command/address input slew rate ≥ 1V/ns. Slow command/address input slew rate ≥ 0.5V/ns. If the slew rate is less than 0.5V/ns, timing must be derated: tIS has **an additional 50ps (pending) per each 100mV/ns** reduction in slew rate from the 0.5V/ns. **tIH has Ops added (pending)**; that is, it remains constant. If the slew rate exceeds 4.5V/ns, functionality is uncertain.
- tHZ and tLZ transitions occur in the same access time windows as valid data transitions. These parameters are not referenced to a specific voltage level, but specify when the device output is no longer driving (HZ) or begins driving (LZ).
- The maximum limit for this parameter is not a device limit. The device will operate with a greater value for this parameter, but system performance (bus turnaround) will degrade accordingly.
- This is not a device limit. The device will operate with a negative value, but system performance could be degraded due to bus turnaround.
- It is recommended that DQS be valid (HIGH or LOW) on or before the WRITE command.
- The refresh period equals 64ms. This equates to an average refresh rate of 7.8125μs.
- The valid data window is derived by achieving other specifications: tHP (tCLK/2), tDQSQ, and tQH (tHP - tQHS). The data valid window derates directly proportional with the CLK duty cycle and a practical data valid window can be derived. The CLK is allowed a maximum duty cycle variation of 45/55. Functionality is uncertain when operating beyond a 45/55 ratio.
- Referenced to each output group: DQS0 with DQ0–DQ7; and DQ1 with DQ8–DQ1
- READs and WRITEs with auto precharge are allowed to be issued before tRAS (MIN) can be satisfied prior to the internal PRECHARGE command being issued.
- tHZ (MAX) will prevail over tDQSCLK (MAX) + tRPST (MAX) condition.
- tHP (MIN) is the lesser of tCL minimum and tCH minimum actually applied to the device CLK and /CLK inputs, collectively.
- Random addressing changing 50 percent of data changing at every transfer.
- CKE must be active (HIGH) during the entire time a REFRESH command is executed. That is, from the time the AUTO REFRESH command is registered, CKE must be active at each rising CLK edge, until tRFC later.
- The transition time for input signals (/CAS, CKE, /CS, DM, DQ, DQS, /RAS, /WE, and addresses) are measured between VIL(DC) to VIH(AC) for rising input signals and VIH(DC) to VIL(AC) for falling input signals.
- tDAL = (tWR/tCLK) + (tRP/tCLK) + 1tCLK : for each term, if not already an integer, round to the next higher integer.
- These parameters guarantee device timing but they are not necessarily tested on each device.
- CLK must be toggled a minimum of two times during this period.
- CLK must be toggled a minimum of one time during this period.
- This device can support 45/55 of duty rate for tDQSCLK in case of 50/50 of CLK input.

## Operations

### Bank/row Activation

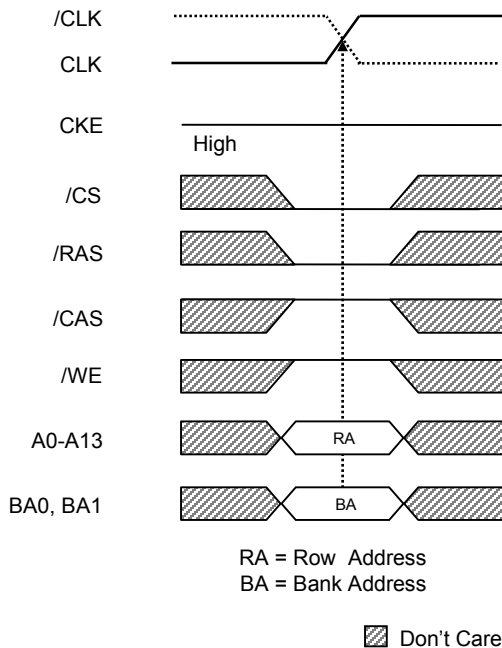
Before any READ or WRITE commands can be issued to a bank within the Low Power DDR SDRAM, a row in that bank must be “opened.” This is accomplished via the ACTIVE command, which selects both the bank and the row to be activated, as shown in Figure 5.

After a row is opened with an ACTIVE command, a READ or WRITE command may be issued to that row, subject to the tRCD specification. tRCD (MIN) should be divided by the clock period and rounded up to the next whole number to determine the earliest clock edge after the ACTIVE command on which a READ or WRITE command can be entered. For example, a tRCD specification of 18ns with a 133 MHz clock (7.5ns period) results in 2.4 clocks rounded to 3.

A subsequent ACTIVE command to a different row in the same bank can only be issued after the previous active row has been “closed” (precharged). The minimum time interval between successive ACTIVE commands to the same bank is defined by tRC.

A subsequent ACTIVE command to another bank can be issued while the first bank is being accessed, which results in a reduction of total row-access overhead. The minimum time interval between successive ACTIVE commands to different banks is defined by tRRD.

**Figure 5: Activating a Specific Row in a Specific Bank**



## READ

READ bursts are initiated with a READ command, as shown in Figure 6 on page 26.

The starting column and bank addresses are provided with the READ command and auto precharge is either enabled or disabled for that burst access. If auto precharge is enabled, the row being accessed is precharged at the completion of the burst. For the READ commands used in the following illustrations, auto precharge is disabled.

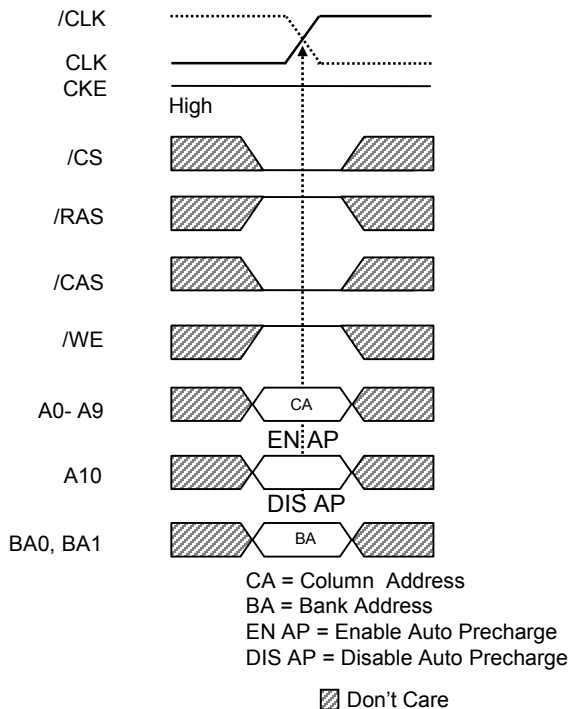
During READ bursts, the valid data-out element from the starting column address will be available following the CAS latency after the READ command. Each subsequent data out element will be valid nominally at the next positive or negative clock edge (i.e., at the next crossing of CLK and /CLK). Figure 7 on page 27 shows general timing for each possible CAS latency setting. DQS is driven by the Low Power DDR SDRAM along with output data. The initial LOW state on DQS is known as the read preamble; the LOW state coincident with the last data-out element is known as the read postamble.

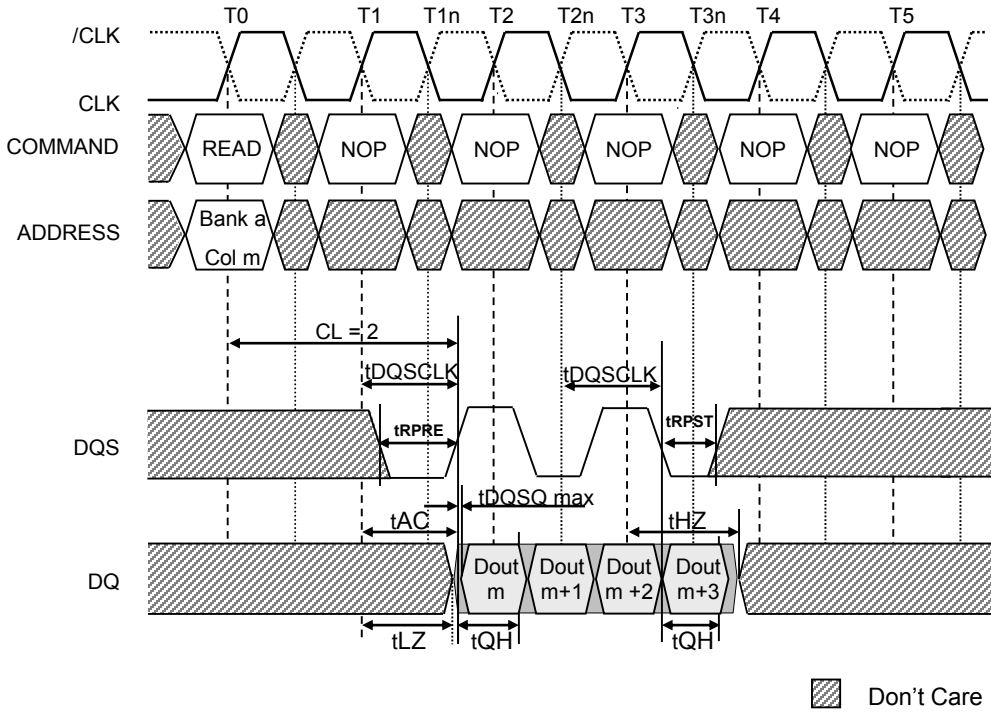
Upon completion of a burst, assuming no other commands have been initiated, the DQs will go High-Z. A detailed explanation of tDQSCLK (DQS transition skew to CLK) and tAC (data-out transition skew to CLK) is depicted in Figure 28 on page 52.

Data from any READ burst may be concatenated with or truncated with data from a subsequent READ command. In either case, a continuous flow of data can be maintained. The first data element from the new burst follows either the last element of a completed burst or the last desired data element of a longer burst which is being truncated. The new READ command should be issued  $x$  cycles after the first READ command, where  $x$  equals the number of desired data element pairs (pairs are required by the  $2n$ -prefetch architecture). This is shown in Figure 8 on page 28.

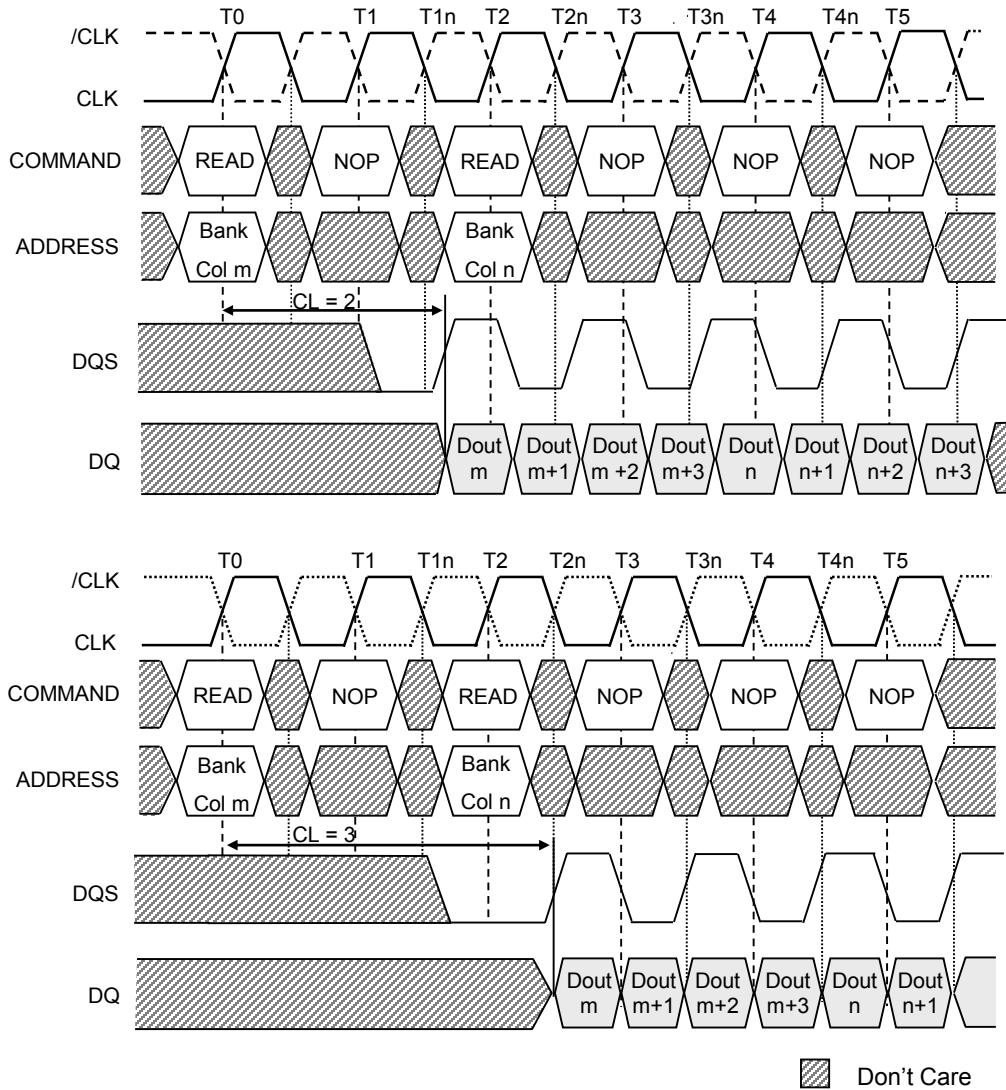
A READ command can be initiated on any clock cycle following a previous READ command. Nonconsecutive read data is shown for illustration in Figure 9 on page 29. Full speed random read accesses within a page (or pages) can be performed as shown in Figure 10 on page 30.

**Figure 6: READ Command**

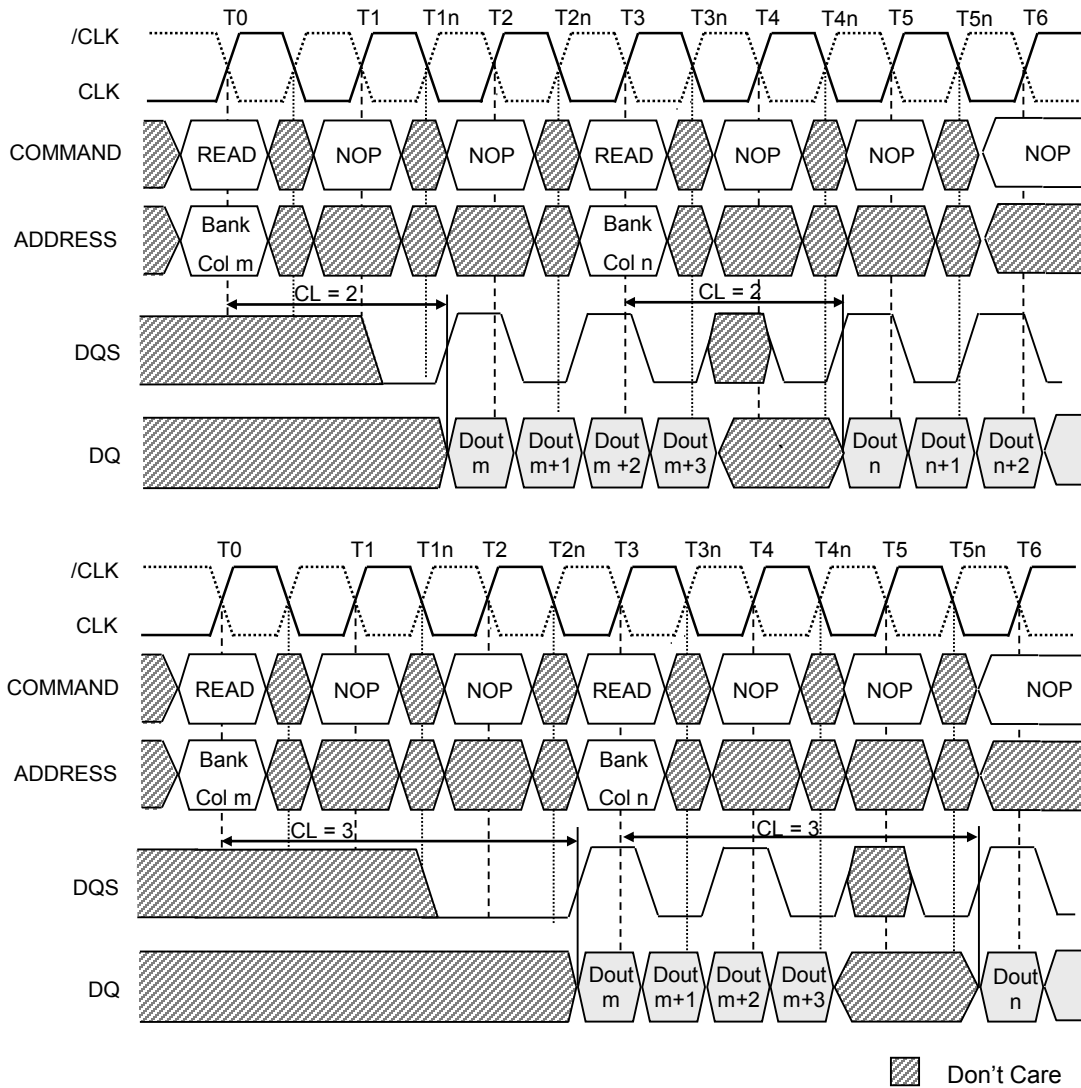


**Figure 7: READ Operation**

**Notes :**

1. Dout m = data-out from column m.
2. BL = 4.
3. Shown with nominal  $t_{AC}$ ,  $t_{DQSCLK}$ , and  $t_{DQSQ}$ .

**Figure 8: Consecutive Read Bursts**

**Notes :**

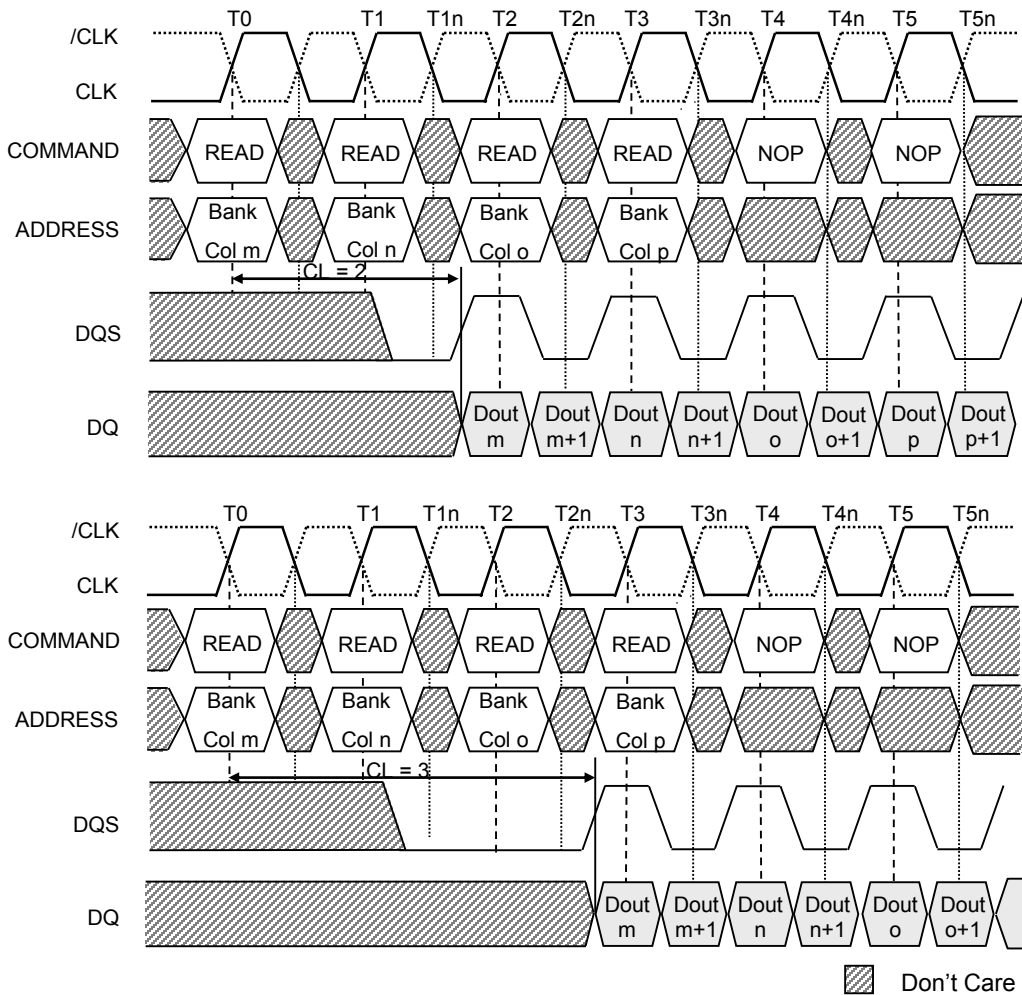
1. Dout m (or n) = data-out from column m (or column n).
2. BL = 4 in the cases shown.
3. Shown with nominal tAC, tDQSCLK, and tDQSQ.
4. This example represents consecutive READ commands issued to the device.

**Figure 9: Read-to-Read Operation**


■ Don't Care

**Notes :**

1. Dout m (or n) = data-out from column m (or column n).
2. BL = 4 in the cases shown
3. Shown with nominal tAC, tDQSCLK, and tDQSQ.
4. This example represents nonconsecutive READ commands issued to the device.

**Figure 10: Random READ Accesses**

**Notes :**

1.  $Dout_m$  (or  $n, o, p$ ) = data-out from column  $m$  (or column  $n, column o, column p$ ).
2.  $BL = 4$  in the cases shown.
3. READs are to an active row in any bank.
4. Shown with nominal  $tAC$ ,  $tDQSCLK$ , and  $tDQSQ$ .

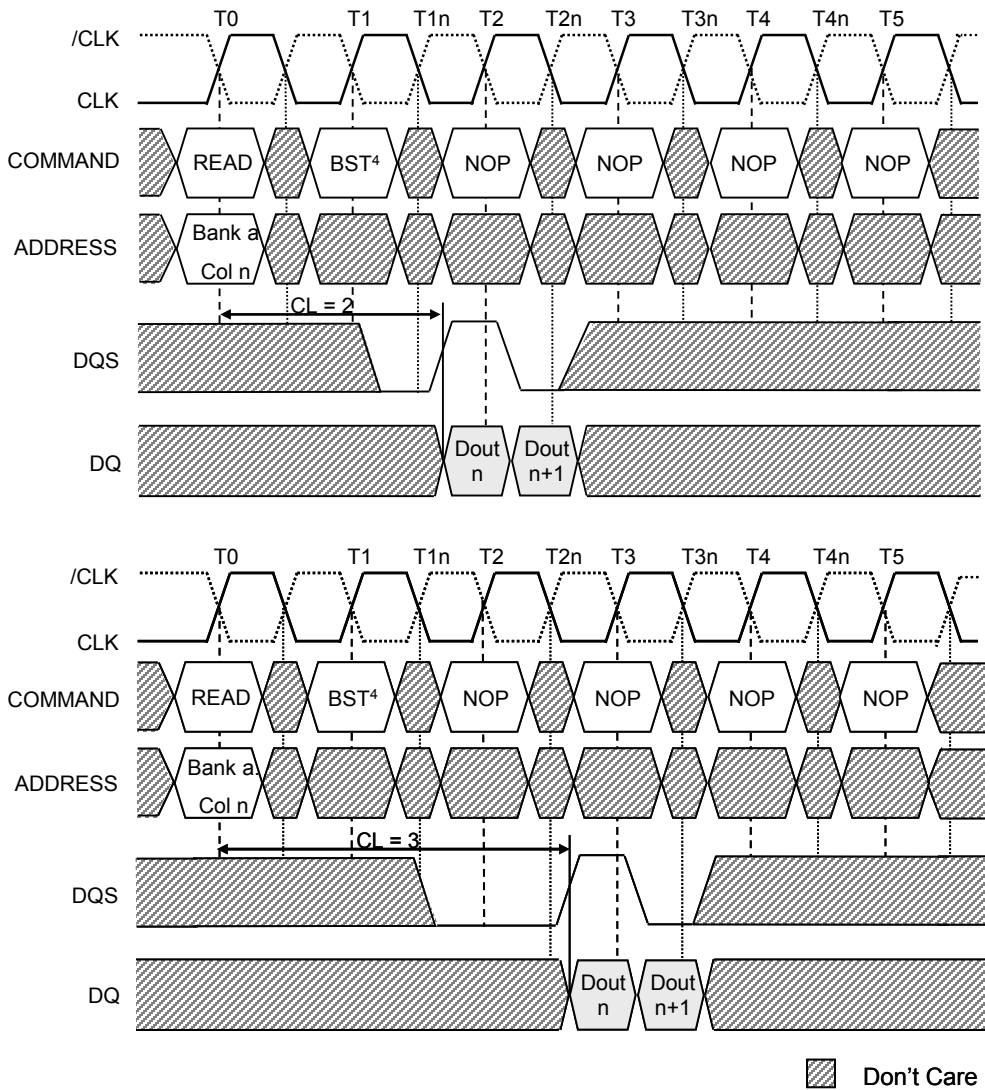
**Truncated READs**

Data from any READ burst may be truncated with a BURST TERMINATE command, as shown in Figure 11 on page 31. The BURST TERMINATE latency is equal to the READ (CAS) latency, i.e., the BURST TERMINATE command should be issued  $x$  cycles after the READ command, where  $x$  equals the number of desired data element pairs (pairs are required by the  $2n$ -prefetch architecture).

Data from any READ burst must be completed or truncated before a subsequent WRITE command can be issued. If truncation is necessary, the BURST TERMINATE command must be used, as shown in Figure 12 on page 32. The  $tDQSS$  (MIN) case is shown; the  $tDQSS$  (MAX) case has a longer bus idle time. ( $tDQSS$  [MIN] and  $tDQSS$  [MAX] are defined in the section on WRITES.)

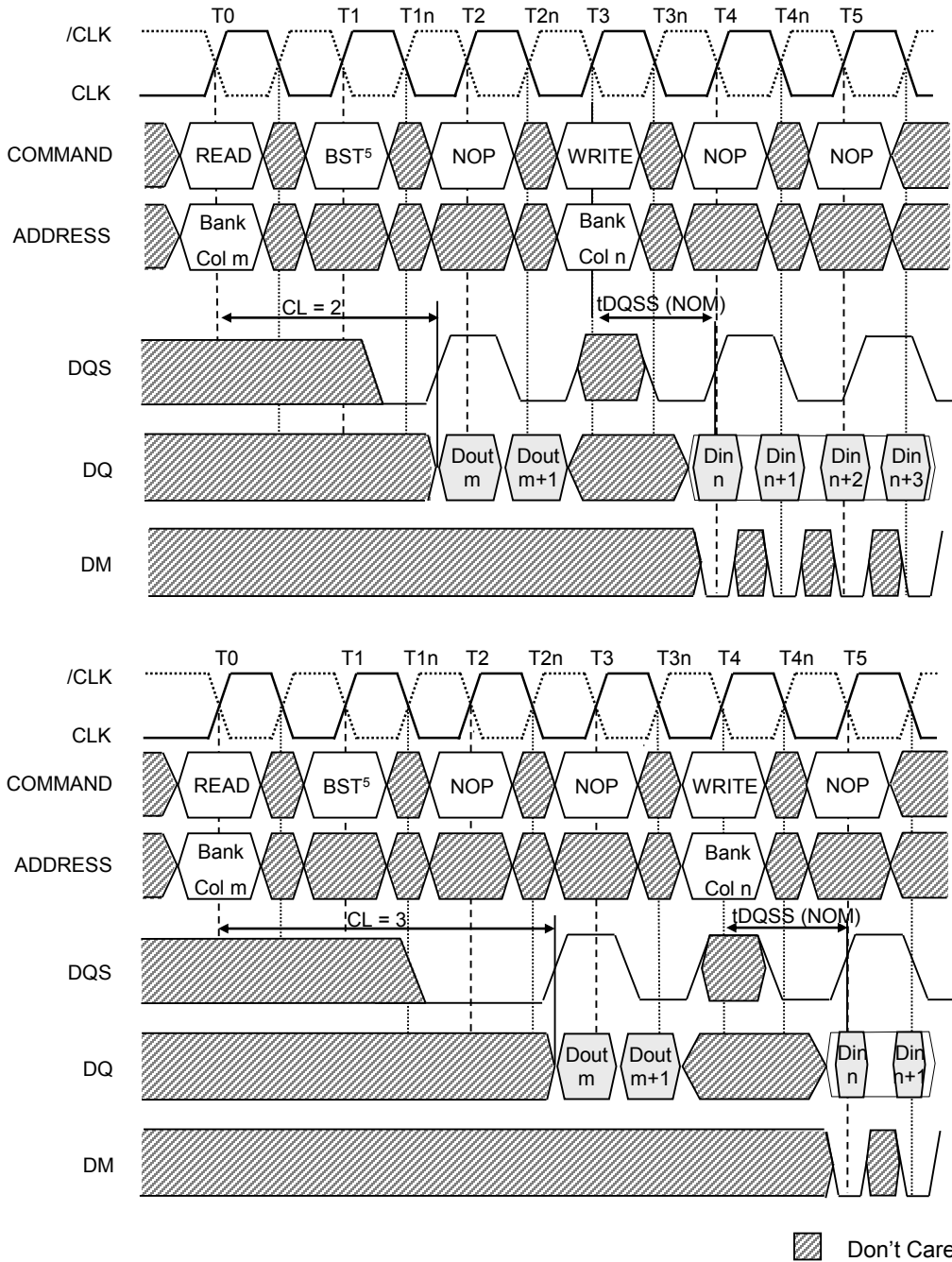
A READ burst may be followed by, or truncated with, a PRECHARGE command to the same bank provided that auto precharge was not activated. The PRECHARGE command should be issued  $x$  cycles after the READ command, where  $x$  equals the number of desired data element pairs (pairs are required by the  $n$ -prefetch architecture). This is shown in Figure 13 on page 33. Following the PRECHARGE command, a subsequent command to the same bank cannot be issued until  $tRP$  is met.

**Note:** Part of the row precharge time is hidden during the access of the last data elements

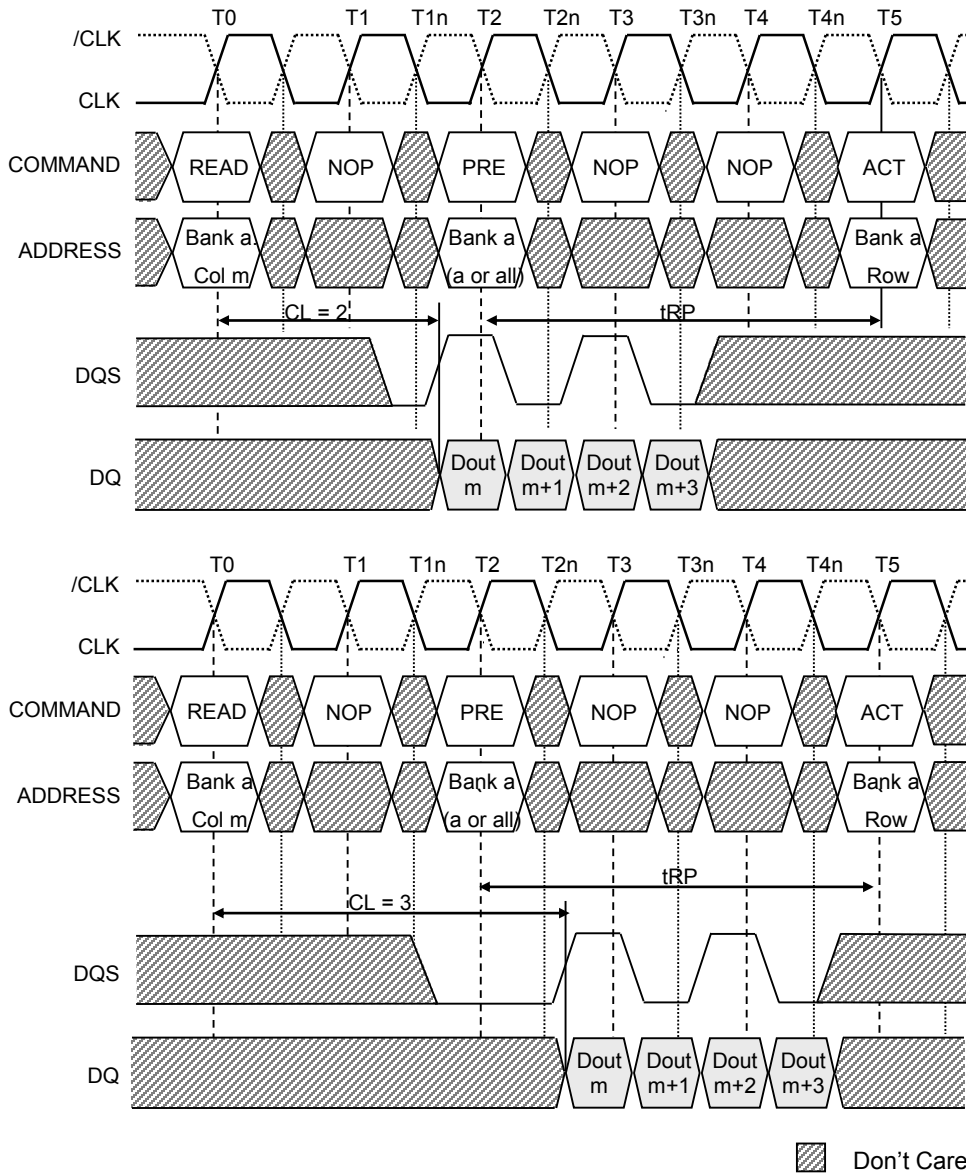
**Figure 11: READ Burst Terminated**

**Notes :**

1. Dout n = data-out from column n.
2. Only valid for BL = 4 and BL = 8.
3. Shown with nominal tAC, tDQSCLK, and tDQSQ.
4. BST = BURST TERMINATE command; page remains open.
5. CKE = HIGH.



**Figure 12: READ-to-WRITE Operation**

**Notes :**

1.  $\text{Dout}_m$  = data-out from column m.
2.  $\text{Din}_n$  = data-in from column n.
3.  $\text{BL} = 4$  in the cases shown (applies for bursts of 8 as well; if  $\text{BL} = 2$ , the  $\text{BST}$  command shown can be a NOP).
4. Shown with nominal  $t_{\text{AC}}$ ,  $t_{\text{DQSCLK}}$ , and  $t_{\text{DQSQ}}$ .
5.  $\text{BST} = \text{BURST TERMINATE}$  command; page remains open.
6.  $\text{CKE} = \text{HIGH}$ .

**Figure 13: READ-to-PRECHARGE Operation**

**Notes :**

1. Dout m = data-out from column m.
2. BL = 4 or an interrupted burst of 8.
3. Shown with nominal tAC, tDQSCLK, and tDQSQ.
4. READ-to-PRECHARGE equals 2 clocks, which allows 2 data pairs of data-out.
5. A READ command with auto precharge enabled, provided tRAS (MIN) is met, would cause a precharge to be performed at x number of clock cycles after the READ command, where  $x = BL / 2$ .
6. PRE = PRECHARGE command; ACT = ACTIVE command.

## WRITE

WRITE bursts are initiated with a WRITE command, as shown in Figure 14 on page 35. The starting column and bank addresses are provided with the WRITE command, and auto precharge is either enabled or disabled for that access. If auto precharge is enabled, the row being accessed is precharged at the completion of the burst. For the WRITE commands used in the following illustrations, auto precharge is disabled.

During WRITE bursts, the first valid data-in element will be registered on the first rising edge of DQS following the WRITE command, and subsequent data elements will be registered on successive edges of DQS. The LOW state on DQS between the WRITE command and the first rising edge is known as the write preamble; the LOW state on DQS following the last data-in element is known as the write postamble.

The time between the WRITE command and the first corresponding rising edge of DQS (tDQSS) is specified with a relatively wide range (from 75 percent to 125 percent of one clock cycle). All of the WRITE diagrams show the nominal case, and where the two extreme cases (i.e., tDQSS [MIN] and tDQSS [MAX]) might not be intuitive, they have also been included. Figure 15 on page 36 shows the nominal case and the extremes of tDQSS for a burst of 4. Upon completion of a burst, assuming no other commands have been initiated, the DQs will remain High-Z and any additional input data will be ignored.

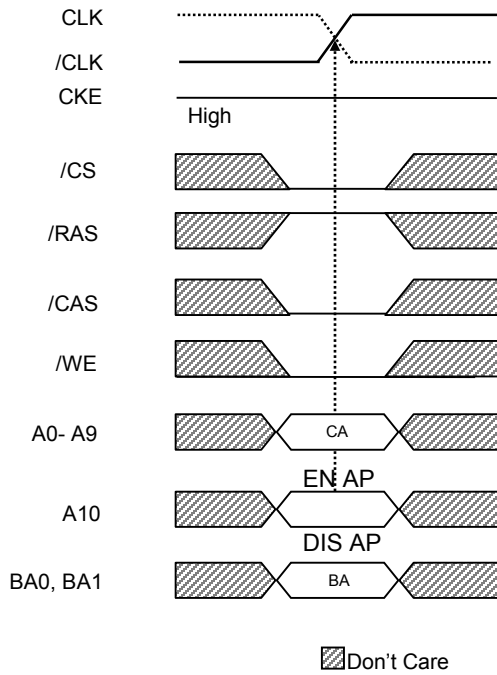
Data for any WRITE burst may be concatenated with or truncated with a subsequent WRITE command. In either case, a continuous flow of input data can be maintained. The new WRITE command can be issued on any positive edge of clock following the previous WRITE command. The first data element from the new burst is applied after either the last element of a completed burst or the last desired data element of a longer burst which is being truncated. The new WRITE command should be issued  $x$  cycles after the first WRITE command, where  $x$  equals the number of desired data element pairs (pairs are required by the  $2n$ -prefetch architecture).

Figure 16 on page 37 shows concatenated bursts of 4. An example of nonconsecutive WRITES is shown in Figure 17 on page 37. Full-speed random write accesses within a page or pages can be performed, as shown in Figure 18 on page 38. Data for any WRITE burst may be followed by a subsequent READ command. To follow a WRITE without truncating the WRITE burst, tWTR should be met, as shown in Figure 19 on page 39.

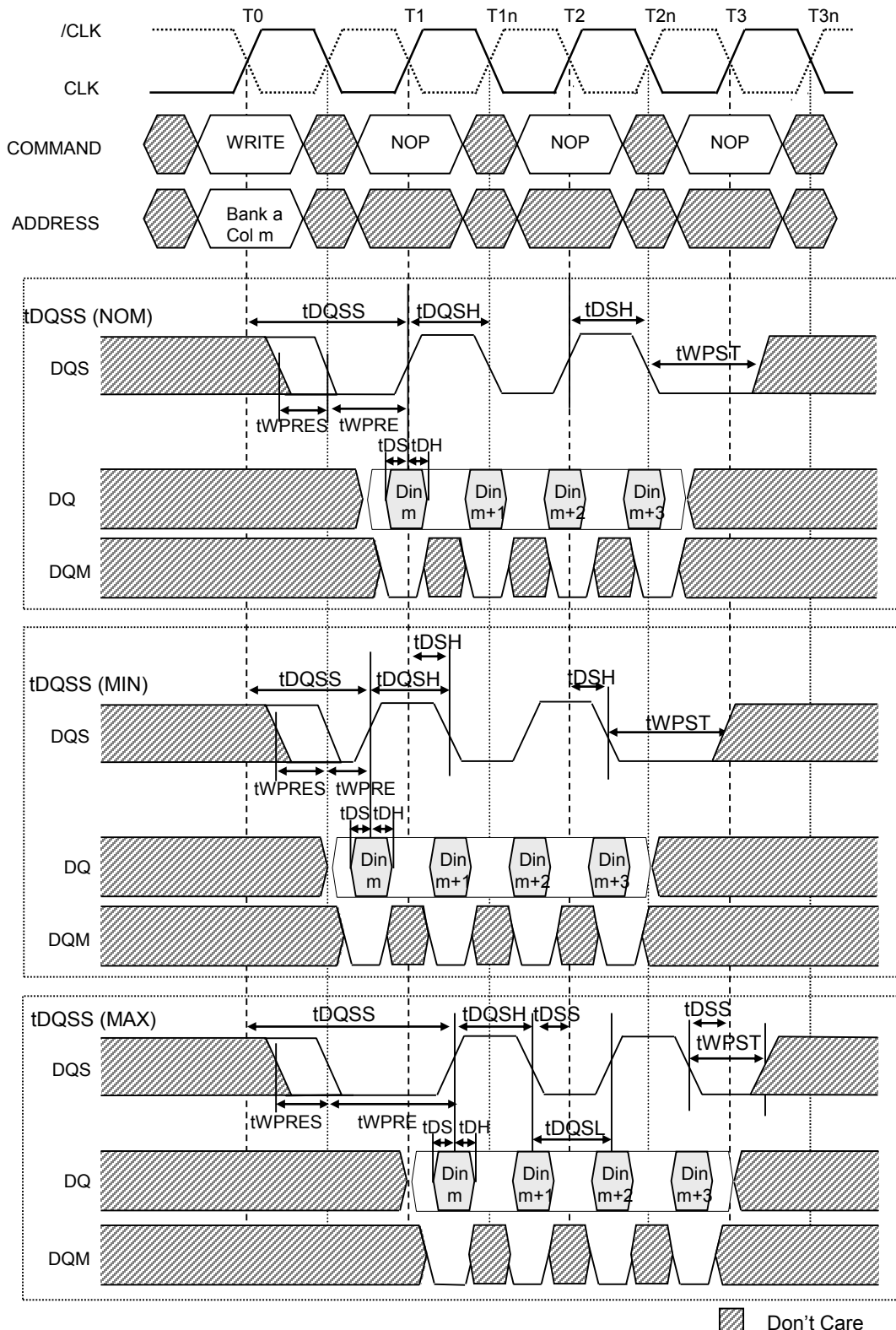
Data for any WRITE burst may be truncated by a subsequent READ command, as shown in Figure 20 on page 40. Note that only the data-in pairs that are registered prior to the tWTR period are written to the internal array, and any subsequent data-in should be masked with DM, as shown in Figure 21 on page 41.

Data for any WRITE burst may be followed by a subsequent PRECHARGE command. To follow a WRITE without truncating the WRITE burst, tWR should be met, as shown in Figure 22 on page 42.

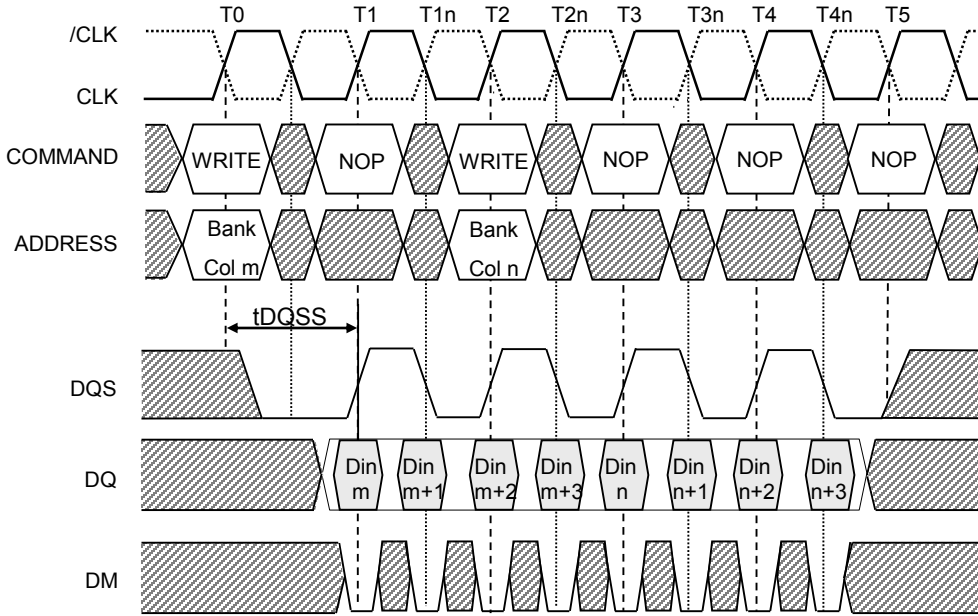
Data for any WRITE burst may be truncated by a subsequent PRECHARGE command, as shown in Figure 23 on page 43 and Figure 24 on page 44. Note that only the data-in pairs that are registered prior to the tWR period are written to the internal array, and any subsequent data-in should be masked with DM, as shown in Figure 23 on page 43 and Figure 24 on page 44. After the PRECHARGE command, a subsequent command to the same bank cannot be issued until tRP is met.

**Figure 14: WRITE Command**

**Note :**

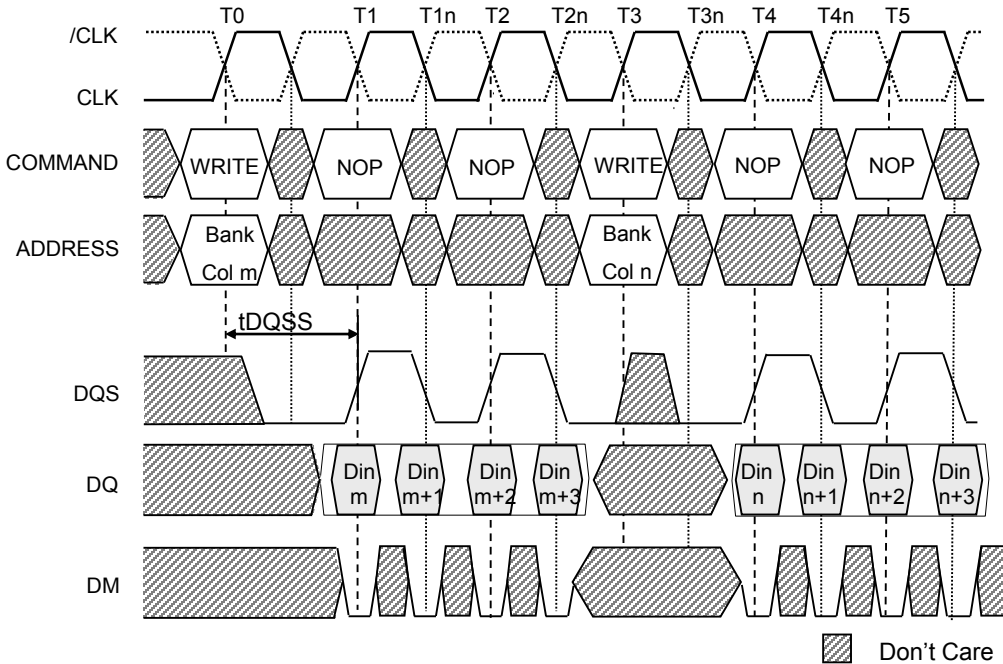
1. DIS AP = Disable Auto Precharge
2. EN AP = Enable Auto Precharge
3. BA = Bank Address
4. CA = Column Address

**Figure 15: WRITE Operation**

**Notes :**

1. Din<sub>m</sub> = data-in for column m.
2. An uninterrupted burst of 4 is shown.
3. A10 is LOW with the WRITE command (auto precharge is disabled).

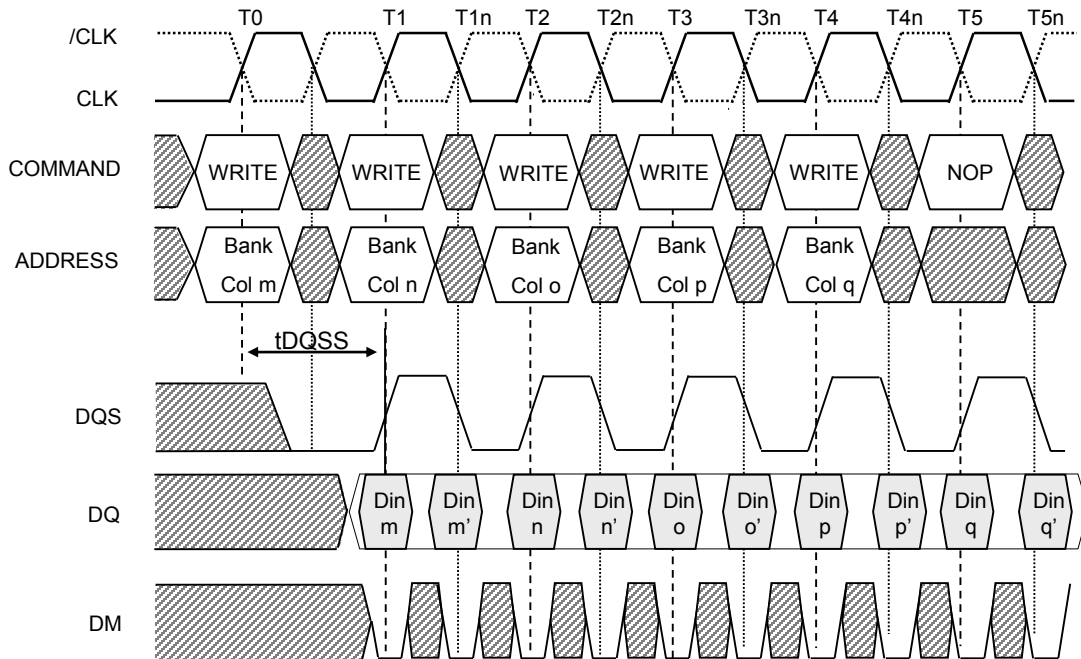
**Figure 16: Consecutive WRITE-to-WRITE**

**Notes :**

1. Din m (n) = data-in for column m (n).
2. An uninterrupted burst of 4 is shown.
3. Each WRITE command may be to any bank.

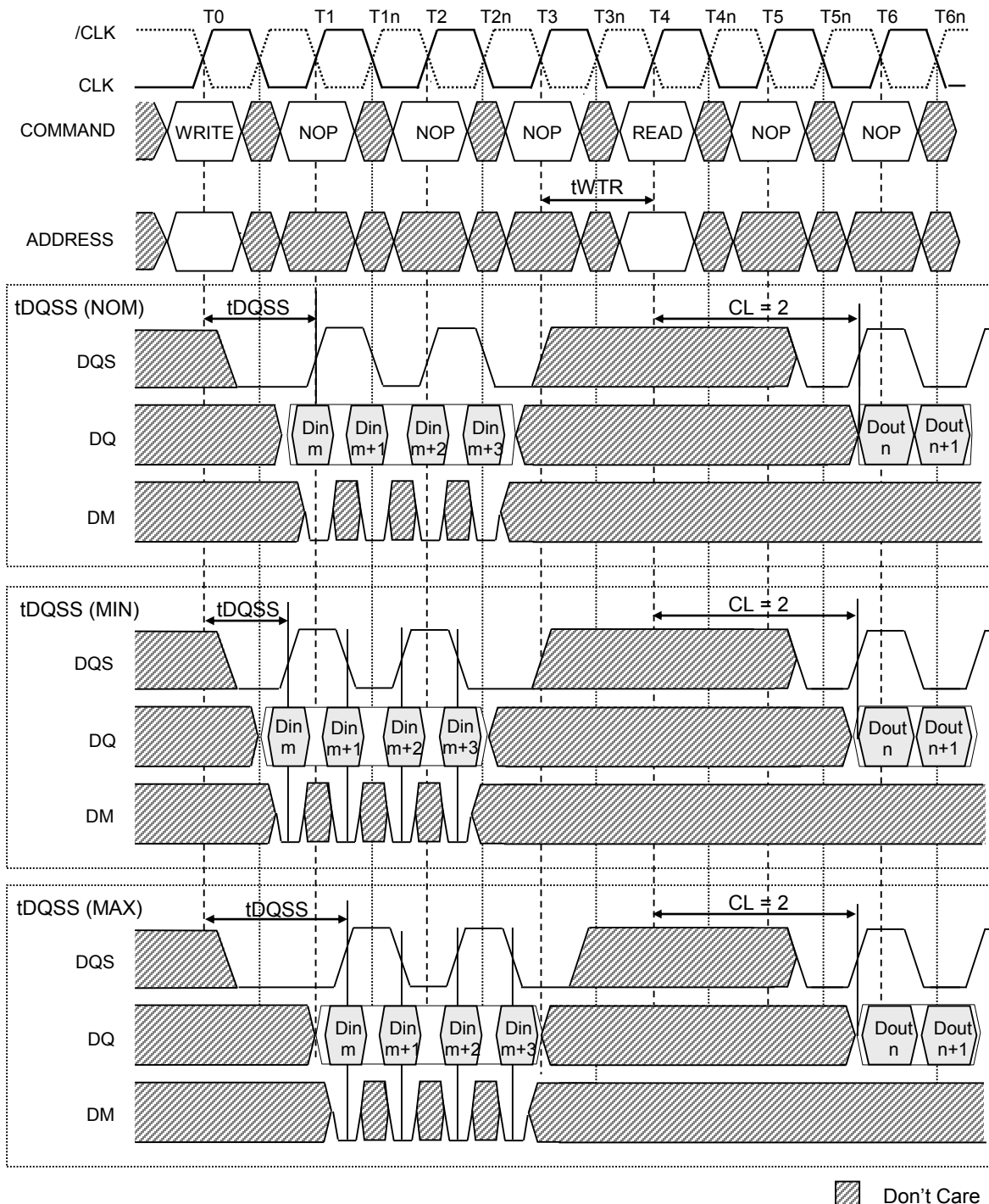
**Figure 17: WRITE-to-WRITE Operation**

 Don't Care

**Notes :**

1. Din m (n) = data-in for column m (n).
2. An uninterrupted burst of 4 is shown.
3. Each WRITE command may be to any bank.

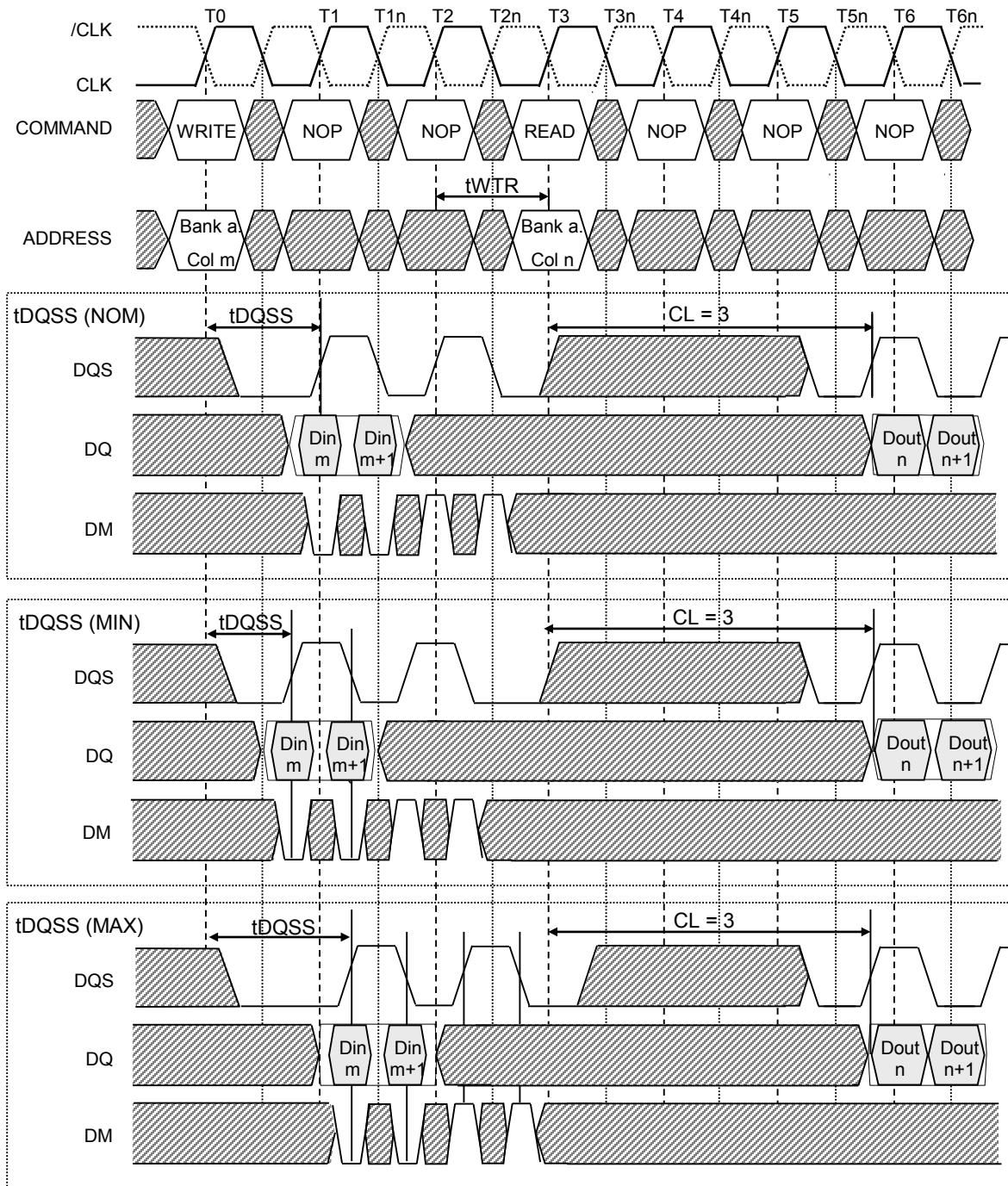
**Figure 18: Random WRITE Cycles**

**Notes :**

1. Din m (or n, o, p, q) = data-in for column m (or n, o, p, q)
2. m' (or n, o, p, q) = the next data-in following Din m (or n, o, p, q), according to the programmed burst order.
3. Programmed BL = 2, 4, or 8 in cases shown.
4. Each WRITE command may be to any bank.

**Figure 19: WRITE-to-READ – Uninterrupting**

**Notes :**

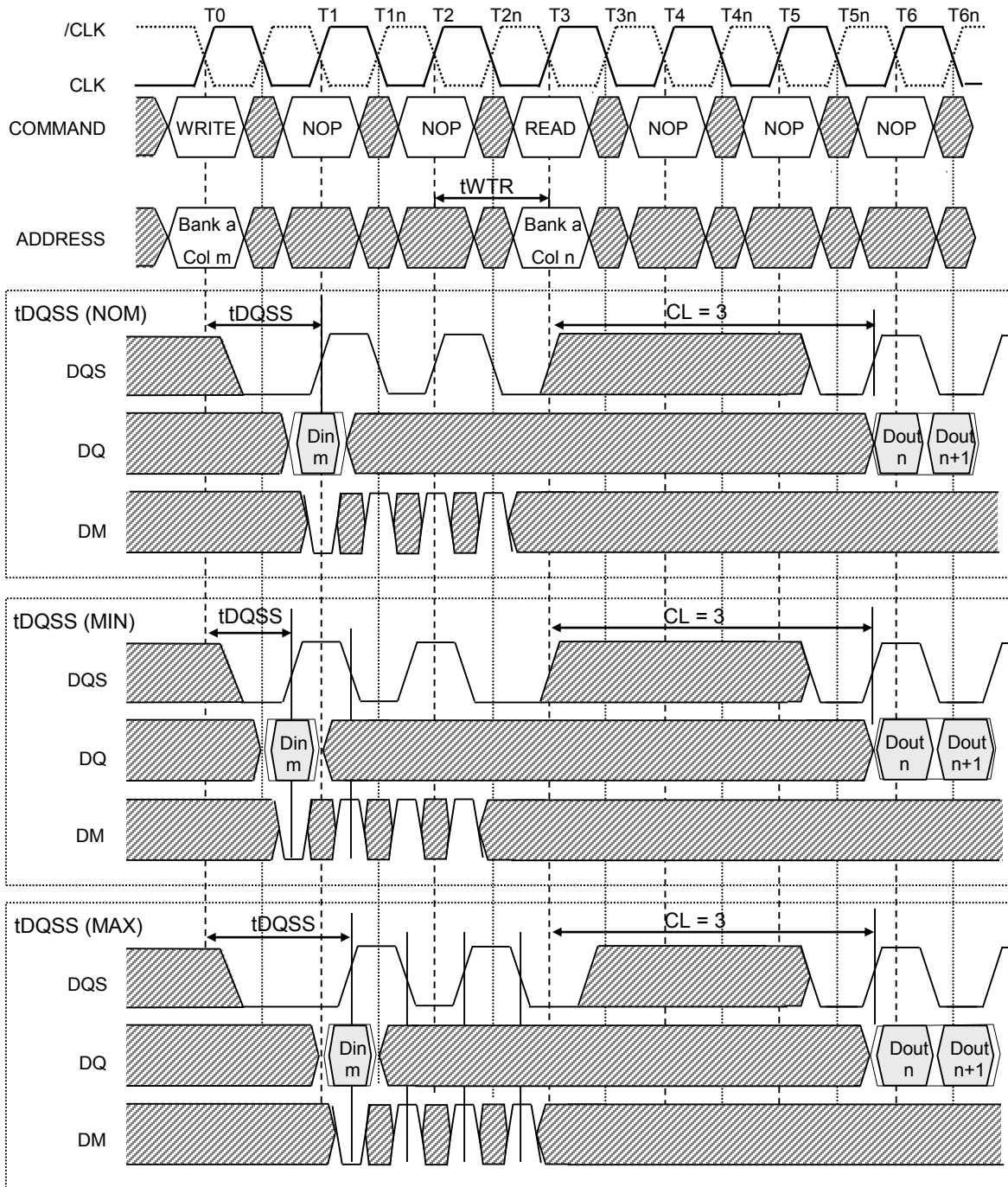
1.  $Din_m$  = data-in for column  $m$ ;  $Dout_n$  = data-out for column  $n$ .
2. An uninterrupted burst of 4 is shown.
3.  $t_{WTR}$  is referenced from the first positive CLK edge after the last data-in pair.
4. The READ and WRITE commands are to same device. However, the READ and WRITE commands may be to different devices, in which case  $t_{WTR}$  is not required and the READ command could be applied earlier.
5. A10 is LOW with the WRITE command (auto precharge is disabled).



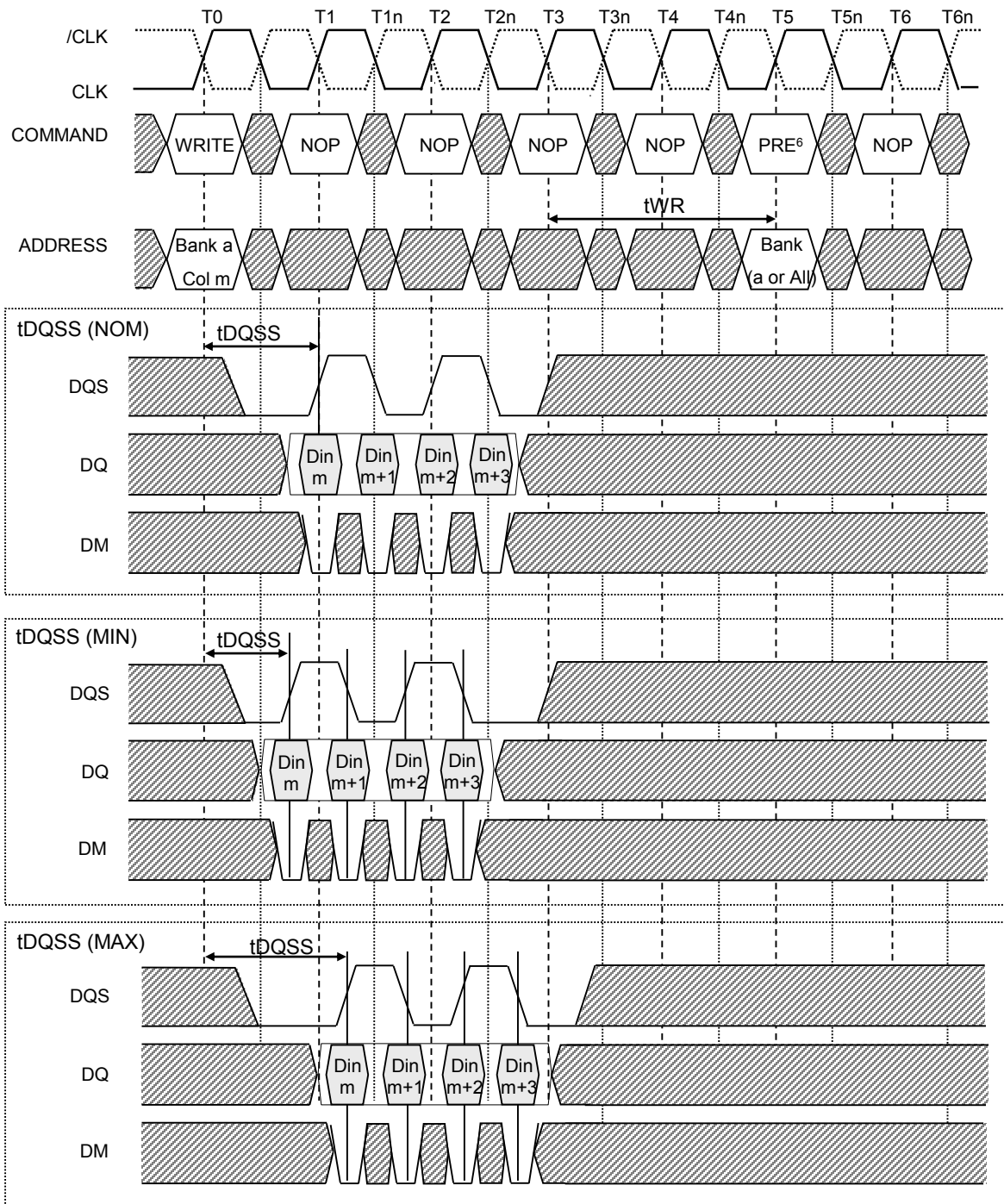
**Figure 20: WRITE-to-READ – Interrupting**

 Don't Care

**Notes :**

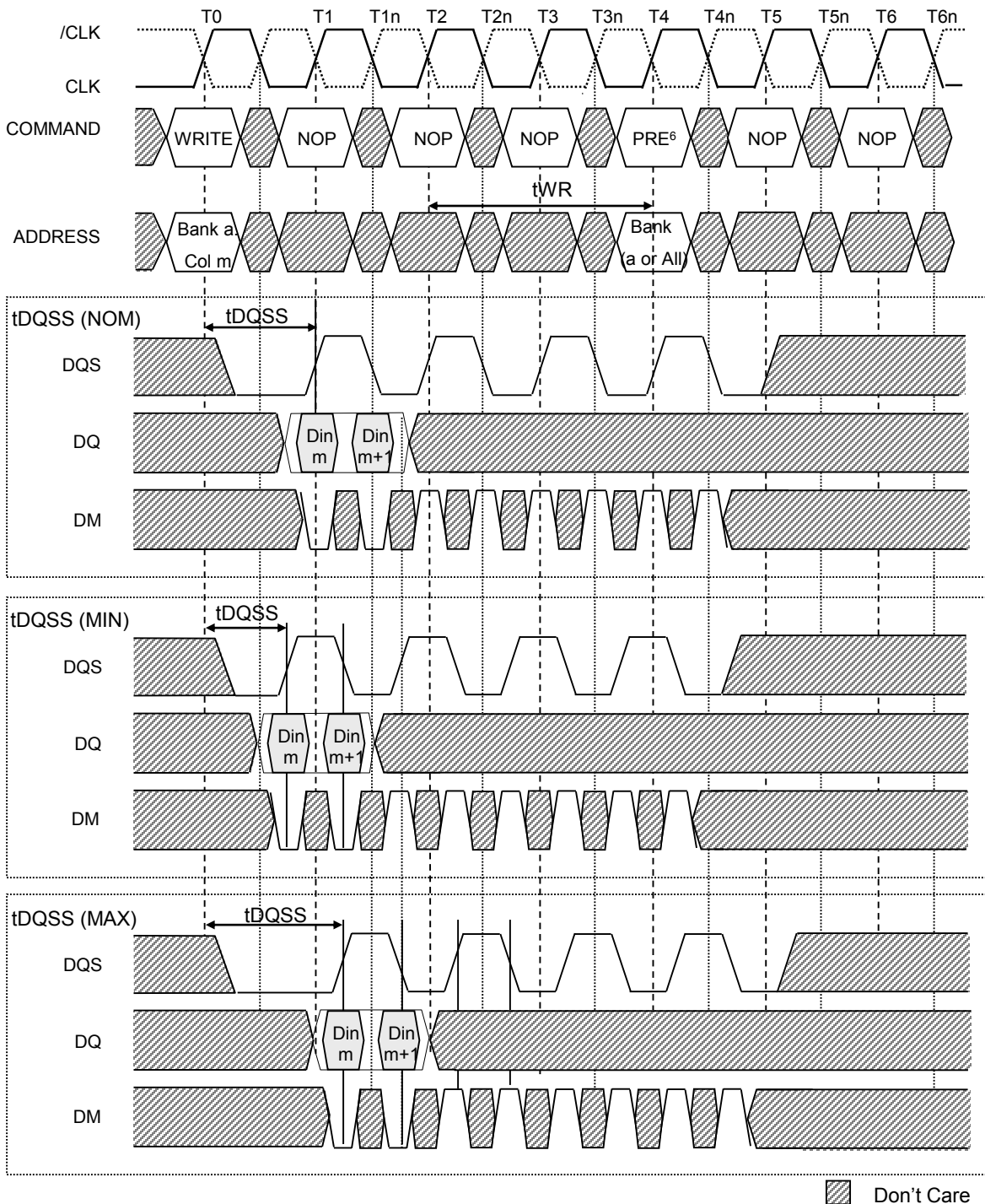
1.  $Din_m$  = data-in for column  $m$ ;  $Dout_n$  = data-out for column  $n$ .
2. An interrupted burst of 4 is shown; two data elements are written.
3.  $t_{WTR}$  is referenced from the first positive  $CLK$  edge after the last data-in pair.
4.  $A10$  is LOW with the WRITE command (auto precharge is disabled).
5.  $DQS$  is required at  $T2$  and  $T2n$  (nominal case) to register  $DM$ .
6. If the burst of 8 was used and  $RD$  is required at  $T5$ ,  $DM$  and  $DQS$  would be required at  $T4$  and  $T4n$  because the READ command would not mask these two data elements.

**Figure 21: WRITE-to-READ – Odd Number of Data, Interrupting**

**Notes :**
 Don't Care

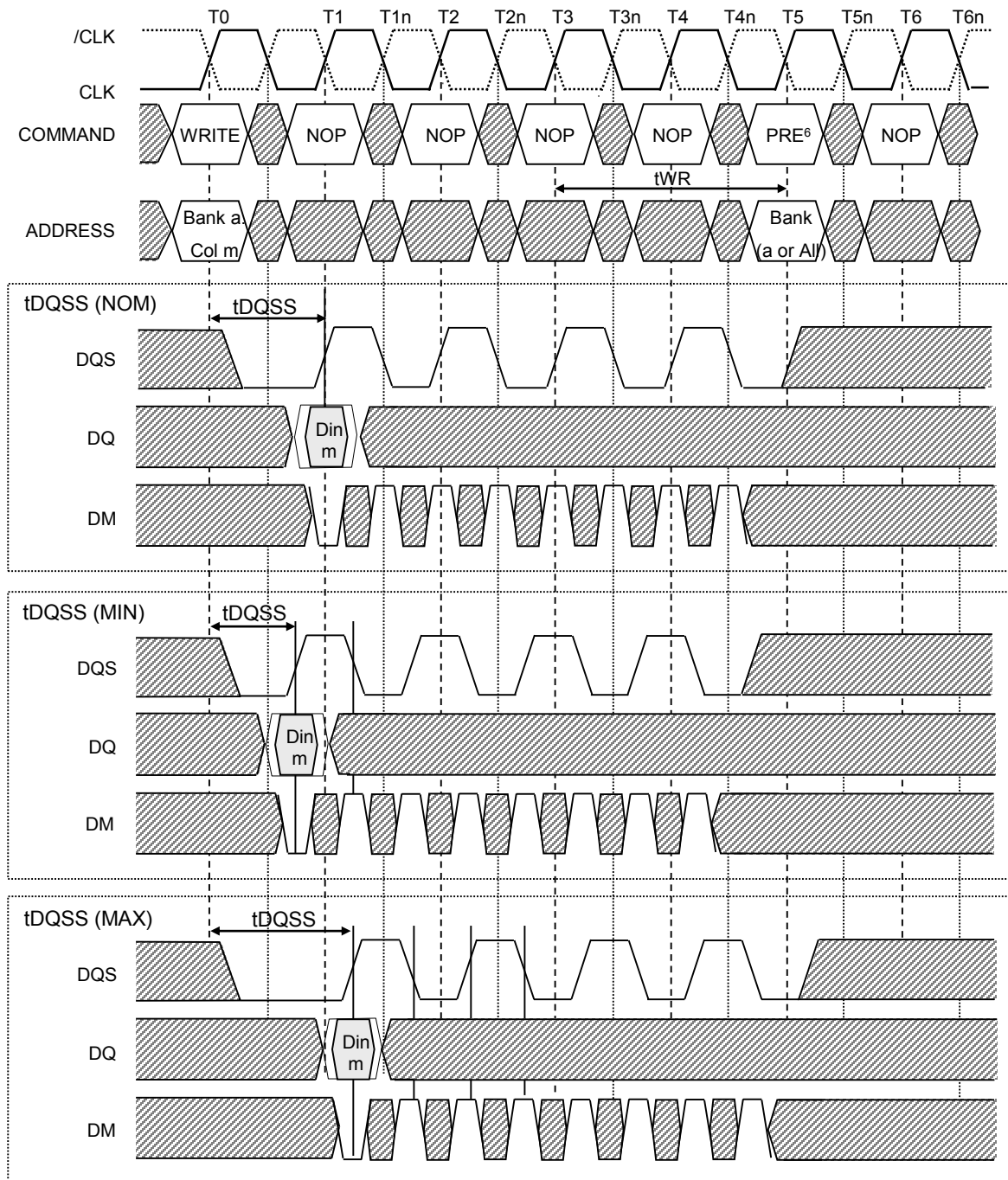
1. Din m = data-in for column m; Dout n = data-out for column n.
2. An interrupted burst of 4 is shown; two data elements are written, three are masked.
3. tWTR is referenced from the first positive CLK edge after the last data-in pair.
4. A10 is LOW with the WRITE command (auto precharge is disabled).
5. DQS is required at T2 and T2n (nominal case) to register DM.
6. If the burst of 8 was used and RD is required at T5, DM and DQS would be required at T4 and T4n because the READ command would not mask these two data elements.

**Figure 22: WRITE-to-PRECHARGE – Uninterrupting**

**Notes :**
 Don't Care

1. Din m = data-in for column m.
2. An uninterrupted burst of 4 is shown.
3. tWR is referenced from the first positive CLK edge after the last data-in pair.
4. The PRECHARGE and WRITE commands are to same device. However, the PRECHARGE and WRITE commands may be to different devices, in which case tWR is not required and the READ command could be applied earlier.
5. A10 is LOW with the WRITE command (auto precharge is disabled).
6. PRE = PRECHARGE command.

**Figure 23: WRITE-to-PRECHARGE – Interrupting**

**Notes :**

1.  $Din_m$  = data-in for column m.
2. An interrupted burst of 8 is shown.
3.  $t_{WR}$  is referenced from the first positive CLK edge after the last data-in pair.
4. The PRECHARGE and WRITE commands are to same device. However, the PRECHARGE and WRITE commands may be to different devices, in which case  $t_{WR}$  is not required and the READ command could be applied earlier.
5. A10 is LOW with the WRITE command (auto precharge is disabled).
6. PRE = PRECHARGE command.

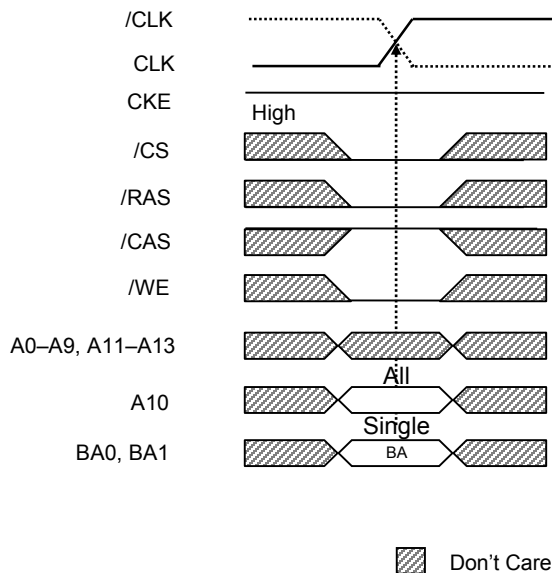
**Figure 24: WRITE-to-PRECHARGE – Odd Number of Data, Interrupting**

**Notes :**

1. Din m = data-in for column m.
2. An interrupted burst of 8 is shown.
3. tWR is referenced from the first positive CLK edge after the last data-in pair.
4. The PRECHARGE and WRITE commands are to same device. However, the PRECHARGE and WRITE commands may be to different devices, in which case tWR is not required and the READ command could be applied earlier.
5. A10 is LOW with the WRITE command (auto precharge is disabled).
6. PRE = PRECHARGE command.

## PRECHARGE

The PRECHARGE command (Figure 25) is used to deactivate the open row in a particular bank or the open row in all banks. The bank(s) will be available for a subsequent row access some specified time (tRP) after the PRECHARGE command is issued. Input A10 determines whether one or all banks are to be precharged, and in the case where only one bank is to be precharged, inputs BA0, BA1 select the bank. When all banks are to be precharged, inputs BA0, BA1 are treated as “Don’t Care.” Once a bank has been precharged, it is in the idle state and must be activated prior to any READ or WRITE commands being issued to that bank.

**Figure 25: PRECHARGE Command**



**Note :**

1. BA = Bank Address.
2. All = All banks to be Precharged, BA1, BA0 are “Don't Care.”
3. Single = Only bank selected by BA1 and BA0 will be precharged.

## Power-Down (CKE Not Active)

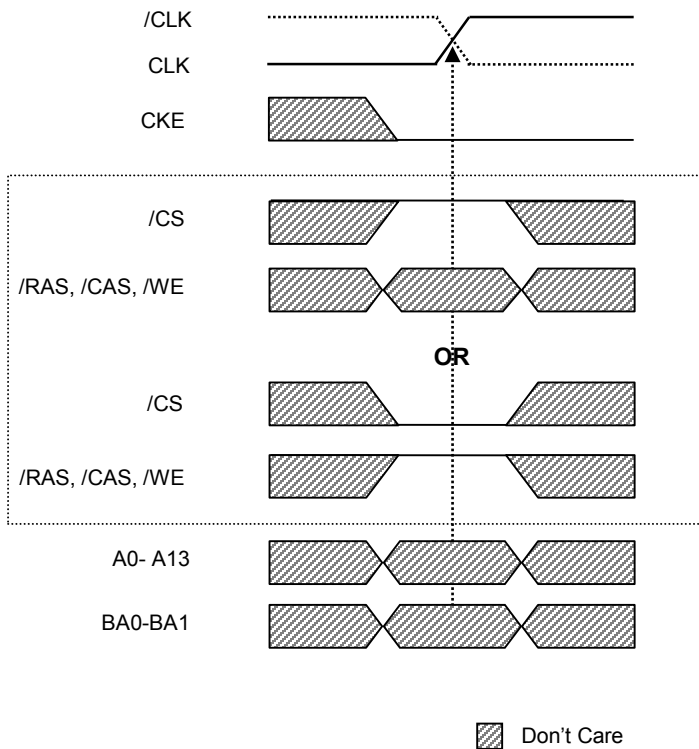
Unlike SDR SDRAMs, DDR SDRAMs require CKE to be active at all times an access is in progress: from the issuing of a READ or WRITE command until completion of the burst; thus a clock suspend is not supported. For READs, a burst completion is defined when the read postamble is satisfied; For WRITEs, a burst completion is defined when the write postamble is satisfied.

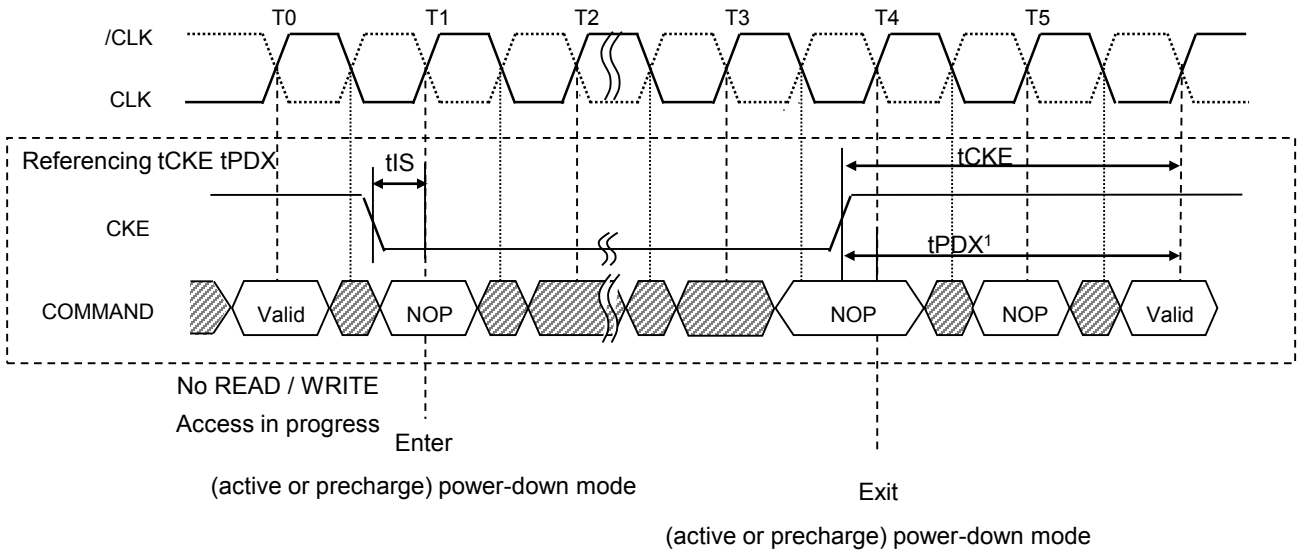
**Power-Down (Active or Precharge)**

Power-down (Figure 27) is entered when CKE is registered LOW. If power-down occurs when all banks are idle, this mode is referred to as precharge power-down; if power down occurs when there is a row active in any bank, this mode is referred to as active power-down. Entering power-down deactivates the input and output buffers, including CLK and /CLK. Exiting power-down requires the device to be at the same voltage as when it entered power-down and a stable clock.

**Note :**

The power-down duration is limited by the refresh requirements of the device. While in power-down, CKE LOW must be maintained at the inputs of the Low Power DDR SDRAM, while all other input signals are "Don't Care." The power-down state is synchronously exited when CKE is registered HIGH (in conjunction with a NOP or DESELECT command). NOPs or DESELECT commands must be maintained on the command bus until tPDX is satisfied.

**Figure 26: Power-Down Command (Active or Precharge)**


**Figure 27: Power-Down (Active or Precharge)**


**Notes:** 1. Clock must toggle a minimum of once during this time.

## Truth Tables

**Table 13: Truth Table – CKE**

**Notes:** 1–5

CKEn-1	CKEn	Current State	COMMANDn	ACTIONn	Notes
L	L	(Active) Power-Down	X	Maintain (active) power-down	
L	L	(Precharge) Power-Down	X	Maintain (precharge) power-down	
L	L	Self refresh	X	Maintain self refresh	
L	H	(Active) Power-Down	DESELECT or NOP	Exit (active) power-down	6, 7
L	H	(Precharge) Power-Down	DESELECT or NOP	Exit (precharge) power-down	6, 7
L	H	Self refresh	DESELECT or NOP	Exit self refresh	8, 9
H	L	Bank(s) active	DESELECT or NOP	(Active) power-down entry	
H	L	All banks idle	DESELECT or NOP	(Precharge) power-down entry	
H	L	All banks idle	AUTO REFRESH	Self refresh entry	
H	H		See Table 15 on page 49		
H	H		See Table 15 on page 49		

**Notes :**

1. CKEn is the logic state of CKE at clock edge  $n$ ; CKEn-1 was the state of CKE at the previous clock edge.
2. Current state is the state of the DDR SDRAM immediately prior to clock edge  $n$ .
3. COMMANDn is the command registered at clock edge  $n$ , and ACTIONn is a result of COMMANDn.
4. All states and sequences not shown are illegal or reserved.
5. tCKE pertains.
6. DESELECT or NOP commands should be issued on any clock edges occurring during the tPDX period.
7. The clock must toggle at least once during the tPDX period.
8. DESELECT or NOP commands should be issued on any clock edges occurring during the tXSR period.
9. The clock must toggle at least once during the tXSR period.



**Table 14 Truth Table – Current State Bank *n* - Command to Bank *n***
**Notes : 1–6;** notes appear below and on next page

Current State	/CS	/RAS	/CAS	/WE	Command/Action	Notes
Any	H	X	X	X	DESELECT (NOP/continue previous operation)	
	L	H	H	H	NO OPERATION (NOP/continue previous operation)	
Idle	L	L	H	H	ACTIVE (select and activate row)	
	L	L	L	H	AUTO REFRESH	7
	L	L	L	L	LOAD MODE REGISTER	7
Row active	L	H	L	H	READ (select column and start READ burst)	10
	L	H	L	L	WRITE (select column and start WRITE burst)	10
	L	L	H	L	PRECHARGE (deactivate row in bank or banks)	8
Read (auto precharge disabled)	L	H	L	H	READ (select column and start new READ burst)	10
	L	H	L	L	WRITE (select column and start WRITE burst)	10, 12
	L	L	H	L	PRECHARGE (truncate READ burst, start PRECHARGE)	8
	L	H	H	L	BURST TERMINATE	9
Write (auto precharge disabled)	L	H	L	H	READ (select column and start READ burst)	10, 11
	L	H	L	L	WRITE (select column and start new WRITE burst)	10
	L	L	H	L	PRECHARGE (truncate WRITE burst, start PRECHARGE)	8, 11

**Notes :**

- This table applies when CKEn-1 was HIGH and CKEn is HIGH and after tXSR has been met (if the previous state was self refresh) and after tPDX has been met (if the previous state was power-down).
- This table is bank-specific, except where noted (i.e., the current state is for a specific bank and the commands shown are those allowed to be issued to that bank when in that state). Exceptions are covered in the notes below.
- Current state definitions:
  - Idle: The bank has been precharged, and tRP has been met.
  - Row Active: A row in the bank has been activated, and tRCD has been met. No data bursts/accesses and no register accesses are in progress.
  - Read: A READ burst has been initiated, with auto precharge disabled, and has not yet terminated or been terminated.
  - Write: A WRITE burst has been initiated, with auto precharge disabled, and has not yet terminated or been terminated.
- The following states must not be interrupted by a command issued to the same bank. COMMAND INHIBIT or NOP commands, or allowable commands to the other bank should be issued on any clock edge occurring during these states. Allowable commands to the other bank are determined by its current state and Table 14, and according to Table 15.
  - Precharging: Starts with registration of a PRECHARGE command and ends when tRP is met. Once tRP is met, the bank will be in the idle state.
  - Row Activating: Starts with registration of an ACTIVE command and ends when tRCD is met. Once tRCD is met, the bank will be in the row active state.
  - Read w/Auto-Precharge Enabled: Starts with registration of a READ command with auto precharge enabled and ends when tRP has been met. Once tRP is met, the bank will be in the idle state.
  - Write w/Auto-Precharge Enabled: Starts with registration of a WRITE command with auto precharge enabled and ends when tRP has been met. Once tRP is met, the bank will be in the idle state.
- The following states must not be interrupted by any executable command; DESELECT or NOP commands must be applied on each positive clock edge during these states.
  - Refreshing: Starts with registration of an AUTO REFRESH command and ends when tRFC is met. Once tRFC is met, the DDR SDRAM will be in the all banks idle state.
  - Accessing Mode Register: Starts with registration of a LOAD MODE REGISTER command and ends when tMRD has been met. Once tMRD is met, the Low Power DDR SDRAM will be in the all banks idle state.
  - Precharging All: Starts with registration of a PRECHARGE ALL command and ends when tRP is met. Once tRP is met, all banks will be in the idle state.
- All states and sequences not shown are illegal or reserved.
- Not bank-specific; requires that all banks are idle, and bursts are not in progress.
- May or may not be bank-specific; if multiple banks are to be precharged, each must be in a valid state for precharging.
- Not bank-specific; BURST TERMINATE affects the most recent READ burst, regardless of bank.

10. READs or WRITEs listed in the Command/Action column include READs or WRITEs with auto precharge enabled and READs or WRITEs with auto precharge disabled.
11. Requires appropriate DM masking.
12. A WRITE command may be applied after the completion of the READ burst; otherwise, a BURST TERMINATE must be used to end the READ burst prior to asserting a WRITE command.

**Table 15: Truth Table – Current State Bank *n* - Command to Bank *m***
**Notes : 1–6;** notes appear below and on next page

Current State	/CS	/RAS	/CAS	/WE	Command/Action	Notes
Any	H	X	X	X	DESELECT (NOP/continue previous operation)	
	L	H	H	H	NO OPERATION (NOP/continue previous operation)	
Idle	X	X	X	X	Any command allowed to bank <i>m</i>	
Row activating, active, or precharging	L	L	H	H	ACTIVE (select and activate row)	
	L	H	L	H	READ (select column and start READ burst)	7
	L	H	L	L	WRITE (select column and start WRITE burst)	7
	L	L	H	L	PRECHARGE	
Read (auto precharge Disabled)	L	L	H	H	ACTIVE (select and activate row)	
	L	H	L	H	READ (select column and start new READ burst)	7
	L	H	L	L	WRITE (select column and start WRITE burst)	7, 9
	L	L	H	L	PRECHARGE	
Write (auto precharge Disabled)	L	L	H	H	ACTIVE (select and activate row)	
	L	H	L	H	READ (select column and start READ burst)	7, 8
	L	H	L	L	WRITE (select column and start new WRITE burst)	7
	L	L	H	L	PRECHARGE	
Read (with auto precharge)	L	L	H	H	ACTIVE (select and activate row)	
	L	H	L	H	READ (select column and start new READ burst)	7, 3a
	L	H	L	L	WRITE (select column and start WRITE burst)	7, 9, 3a
	L	L	H	L	PRECHARGE	
Write (with auto precharge)	L	L	H	H	ACTIVE (select and activate row)	
	L	H	L	H	READ (select column and start READ burst)	7, 3a
	L	H	L	L	WRITE (select column and start new WRITE burst)	7, 3a
	L	L	H	L	PRECHARGE	

**Notes :**

- This table applies when  $CKE_{n-1}$  was HIGH and  $CKE_n$  is HIGH and after  $t_{XSR}$  has been met (if the previous state was self refresh) or after  $t_{PDX}$  has been met (if the previous state was power-down).
- This table describes alternate bank operation, except where noted (i.e., the current state is for bank *n* and the commands shown are those allowed to be issued to bank *m*, assuming that bank *m* is in such a state that given command is allowable). Exceptions are covered in the notes below.
- Current state definitions:
  - Idle: The bank has been precharged, and  $t_{RP}$  has been met.
  - Row Active: A row in the bank has been activated, and  $t_{RCD}$  has been met. No data bursts/accesses and no register accesses are in progress.
  - Read: A READ burst has been initiated, with auto precharge disabled, and has not yet terminated or been terminated.
  - Write: A WRITE burst has been initiated, with auto precharge disabled, and has not yet terminated or been terminated.
  - Read with auto precharge enabled: See following text – 3a
  - Write with auto precharge enabled: See following text – 3a
- The read with auto precharge enabled or WRITE with auto precharge enabled states can each be broken into two parts: the access period and the precharge period. For read with auto precharge, the precharge period is defined as if the same burst was executed with auto precharge disabled and then followed with the earliest possible PRECHARGE command that still accesses all of the data in the burst. For write with auto precharge, the precharge period begins when  $t_{WR}$  ends, with  $t_{WR}$  measured as if auto precharge was disabled. The access period starts with registration of the command and ends where the precharge period (or  $t_{RP}$ ) begins.

This device supports concurrent auto precharge such that when a read with auto precharge enabled or a write with auto precharge enabled is enabled any command to other banks is allowed, long as that command does not interrupt the read or write data transfer already in process. either case, all other related limitations apply (e.g., contention between read data and write data must be avoided).
- The minimum delay from a READ or WRITE command with auto precharge enabled, to a command to a different bank is summarized below.

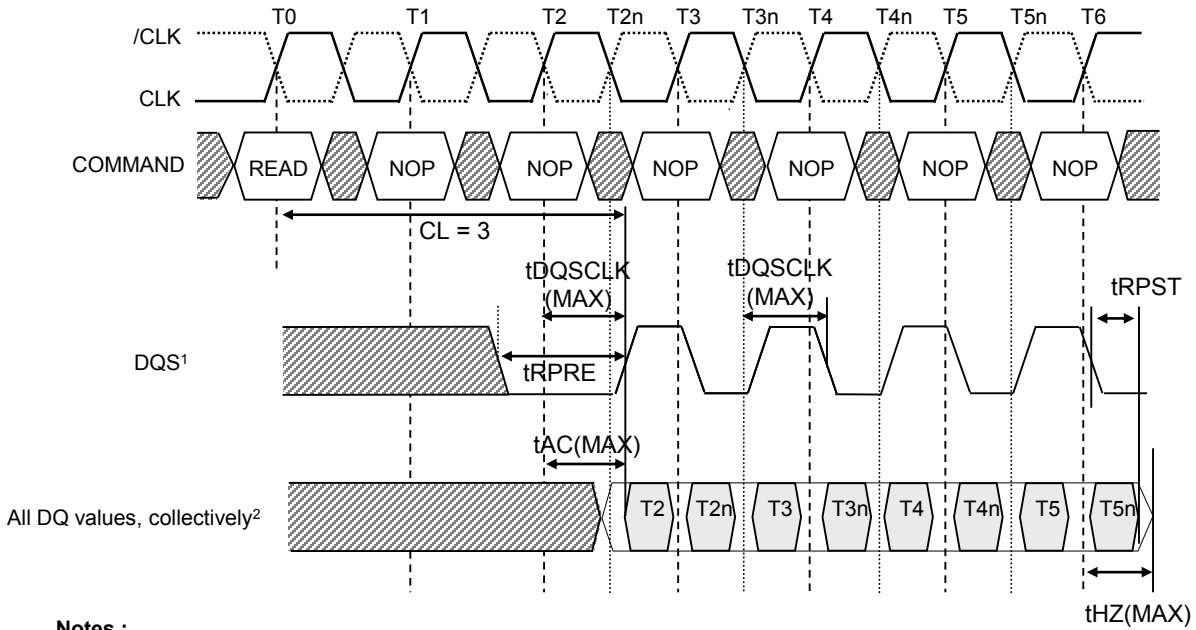
From Command	To Command	Minimum Delay (with Concurrent Auto Precharge)
WRITE w/AP	READ or READ w/AP WRITE or WRITE w/AP PRECHARGE ACTIVE	$[1 + (BL/2)] t_{CLK} + t_{WTR}$ $(BL/2) t_{CLK}$ 1 tCLK 1 tCLK
READ w/AP	READ or READ w/AP WRITE or WRITE w/AP PRECHARGE ACTIVE	$(BL/2) \times t_{CLK}$ $[CLRU + (BL/2)] t_{CLK}$ 1 tCLK 1 tCLK

CLRU = CAS Latency (CL) rounded up to the next integer

BL = Burst Length

4. AUTO REFRESH and LOAD MODE REGISTER commands may only be issued when all banks are idle.
5. A BURST TERMINATE command cannot be issued to another bank; it applies to the bank represented by the current state only.
6. All states and sequences not shown are illegal or reserved.
7. READs or WRITEs listed in the Command/Action column include READs or WRITEs with auto precharge enabled and READs or WRITEs with auto precharge disabled.
8. Requires appropriate DM masking.
9. A WRITE command may be applied after the completion of the READ burst; otherwise, a BURST TERMINATE must be used to end the READ burst prior to asserting a WRITE command.

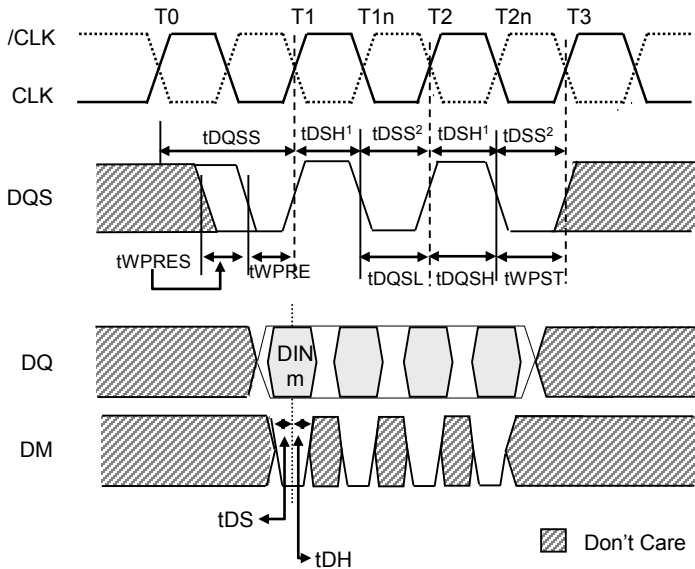
**Figure 28: Data Output Timing – tAC and tDQCLK**



**Notes :**

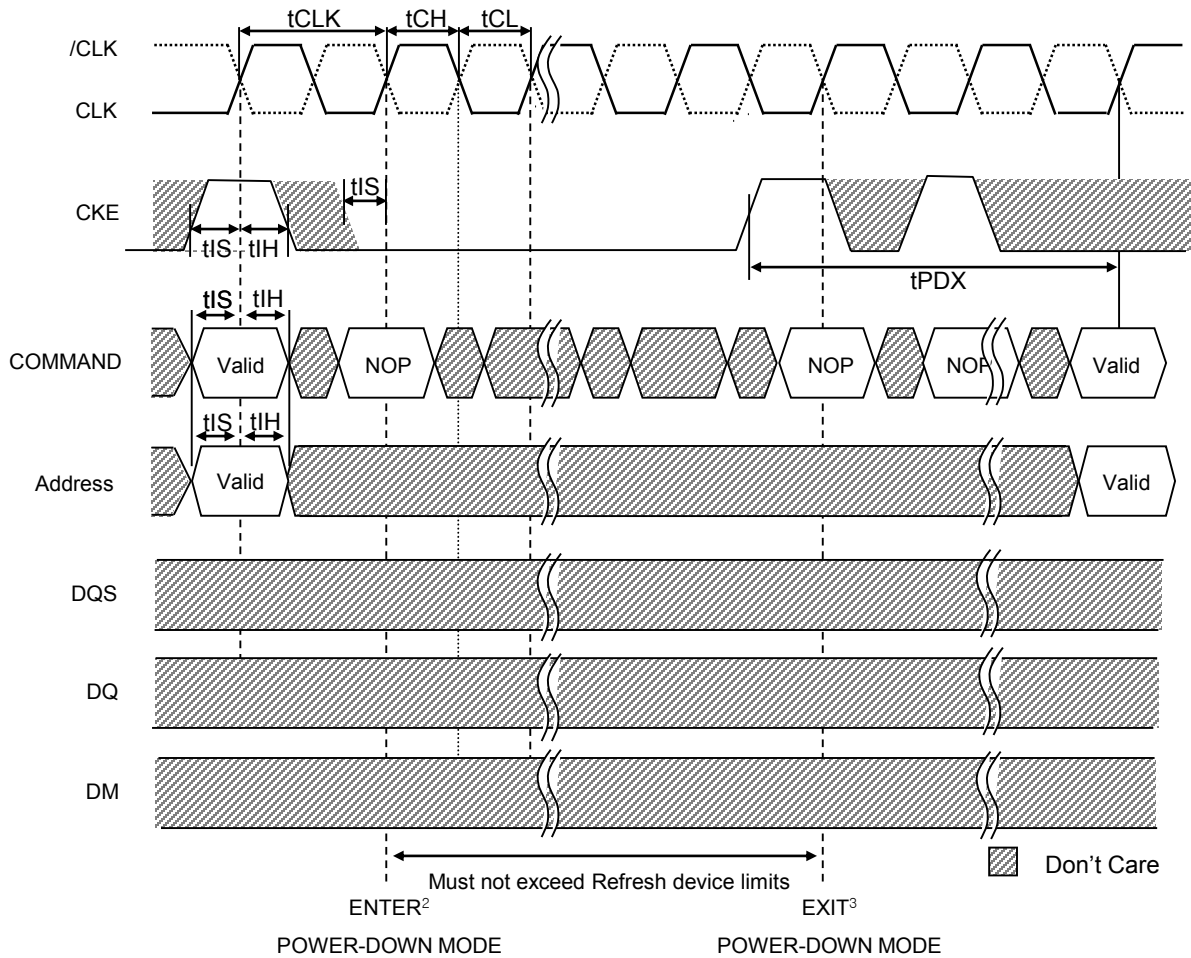
1. DQ transitioning after DQS transition define tDQSQ window.
2. All DQ must transition by tDQSQ after DQS transitions, regardless of tAC.
3. tAC is the DQ output window relative to CLK, and is the "long term" component of DQ skew.

**Figure 29: Data Input Timing**

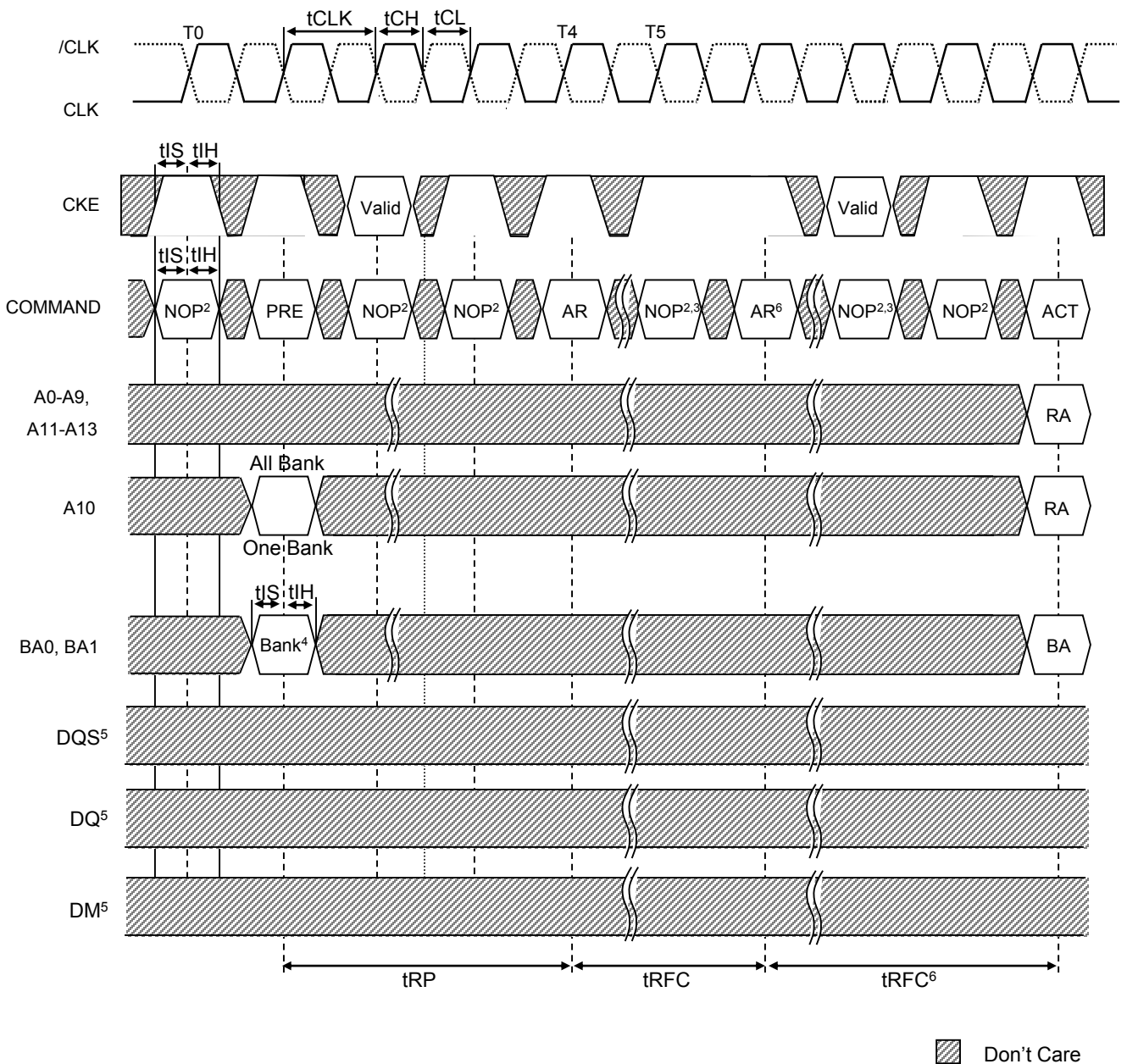


**Notes :**

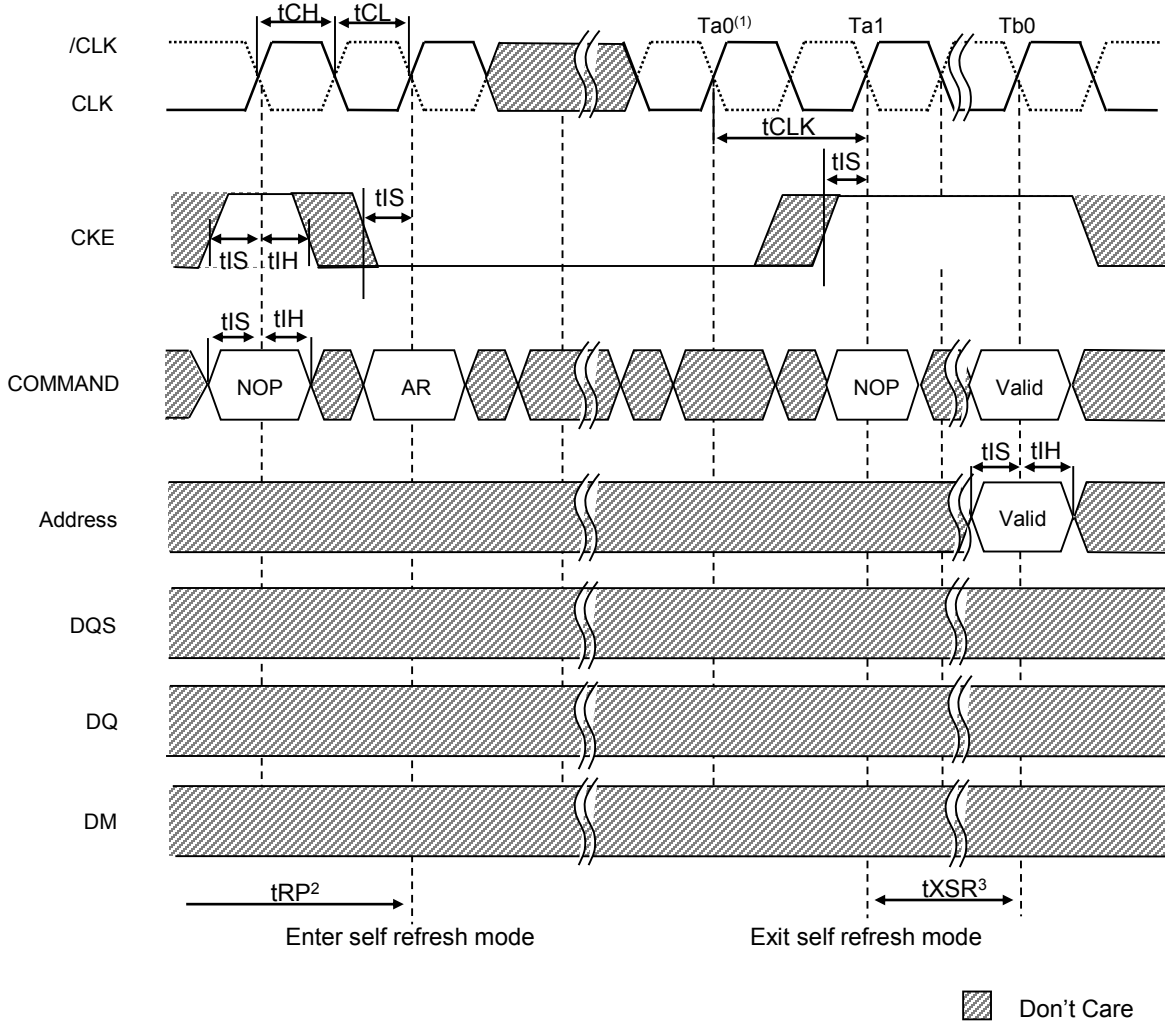
1. tDSH (MIN) generally occurs during tDQSS (MIN).
2. tDSS (MIN) generally occurs during tDQSS (MAX).
3. WRITE command issued at T0.

**Figure 30: Power-Down Mode (Active or Precharge)**

**Notes :**

1. If this command is a PRECHARGE (or if the device is already in the idle state), then the power-down mode shown is precharge power-down. If this command is an ACTIVE (or if at least one row is already active), then the power-down mode shown is active power-down.
2. No column accesses are allowed to be in progress at the time power-down is entered.
3. There must be at least one clock pulse during tPDX time.

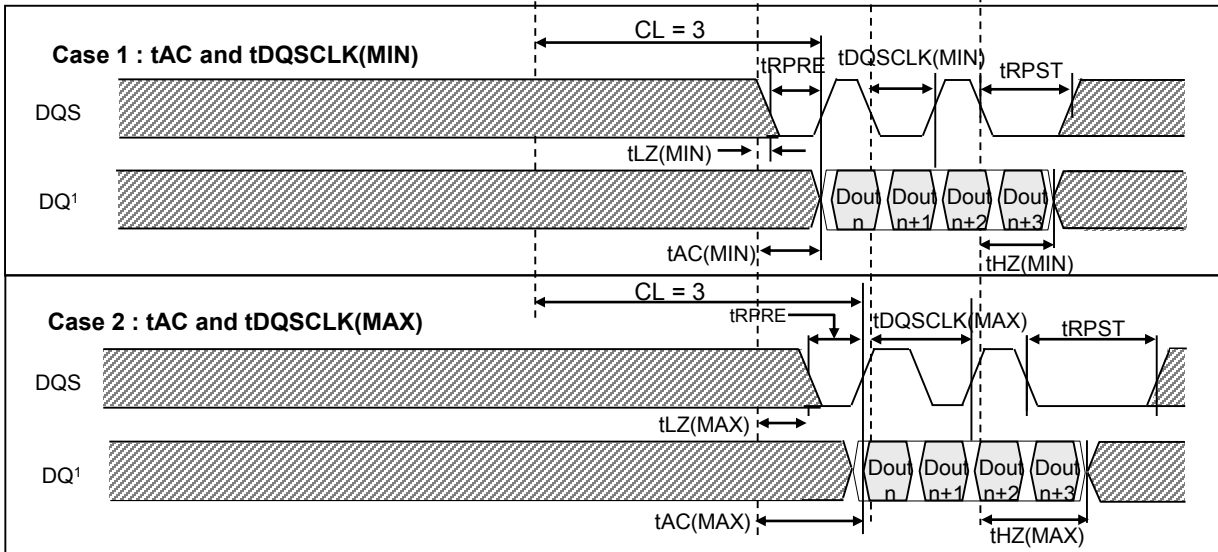
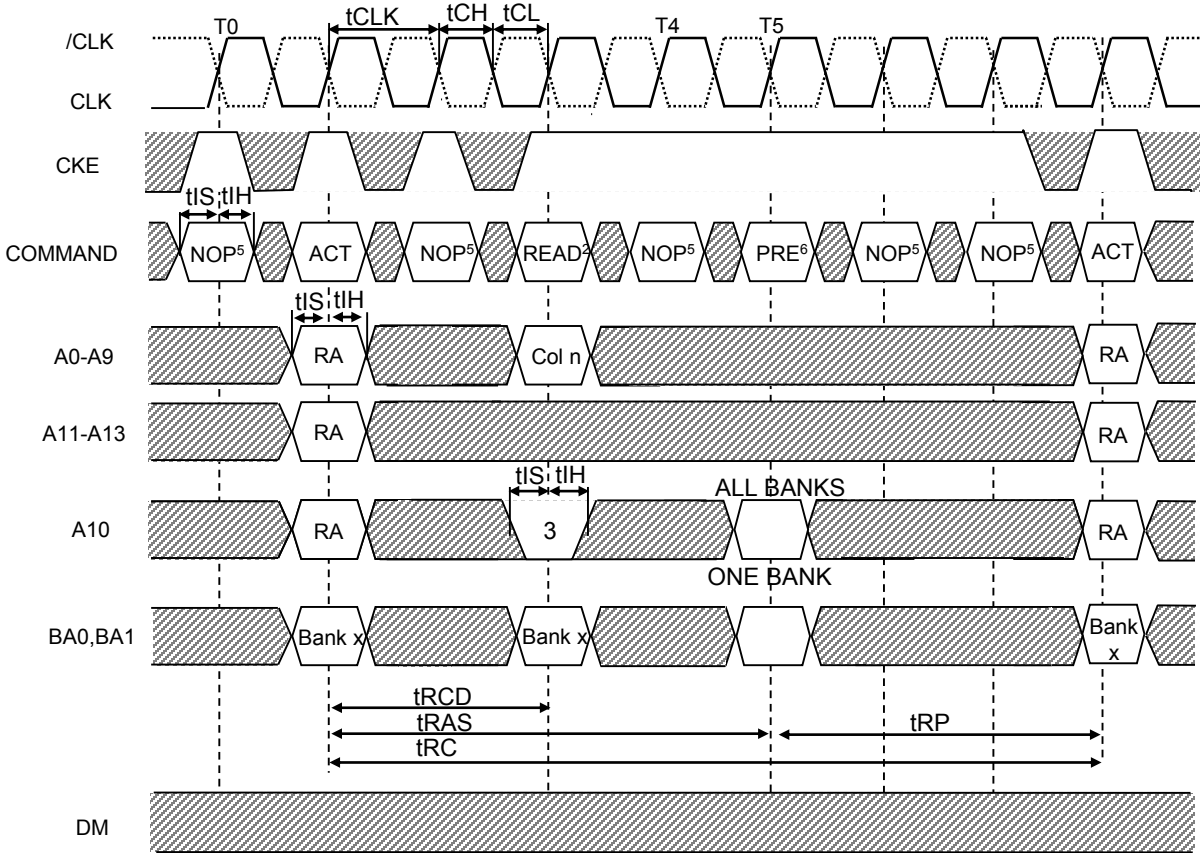
**Figure 31: Auto Refresh Mode**

**Notes :**

1. PRE = PRECHARGE, ACT = ACTIVE, AR = AUTO REFRESH, RA = Row address, BA = Bank address.
2. NOP commands are shown for ease of illustration; other valid commands may be possible at these times. CKE must be active during clock positive transitions.
3. NOP or COMMAND INHIBIT are the only commands allowed until after  $t_{RFC}$  time, CKE must be active during clock positive transitions.
4. "Don't Care" if A10 is HIGH at this point; A10 must be HIGH if more than one bank is active (i.e., must precharge all active banks).
5. DM, DQ, and DQS signals are all "Don't Care"/High-Z for operations shown.
6. The second AUTO REFRESH is not required and is only shown as an example of two back-to-back AUTO REFRESH commands.

**Figure 32: Self Refresh Mode**

**Notes :**

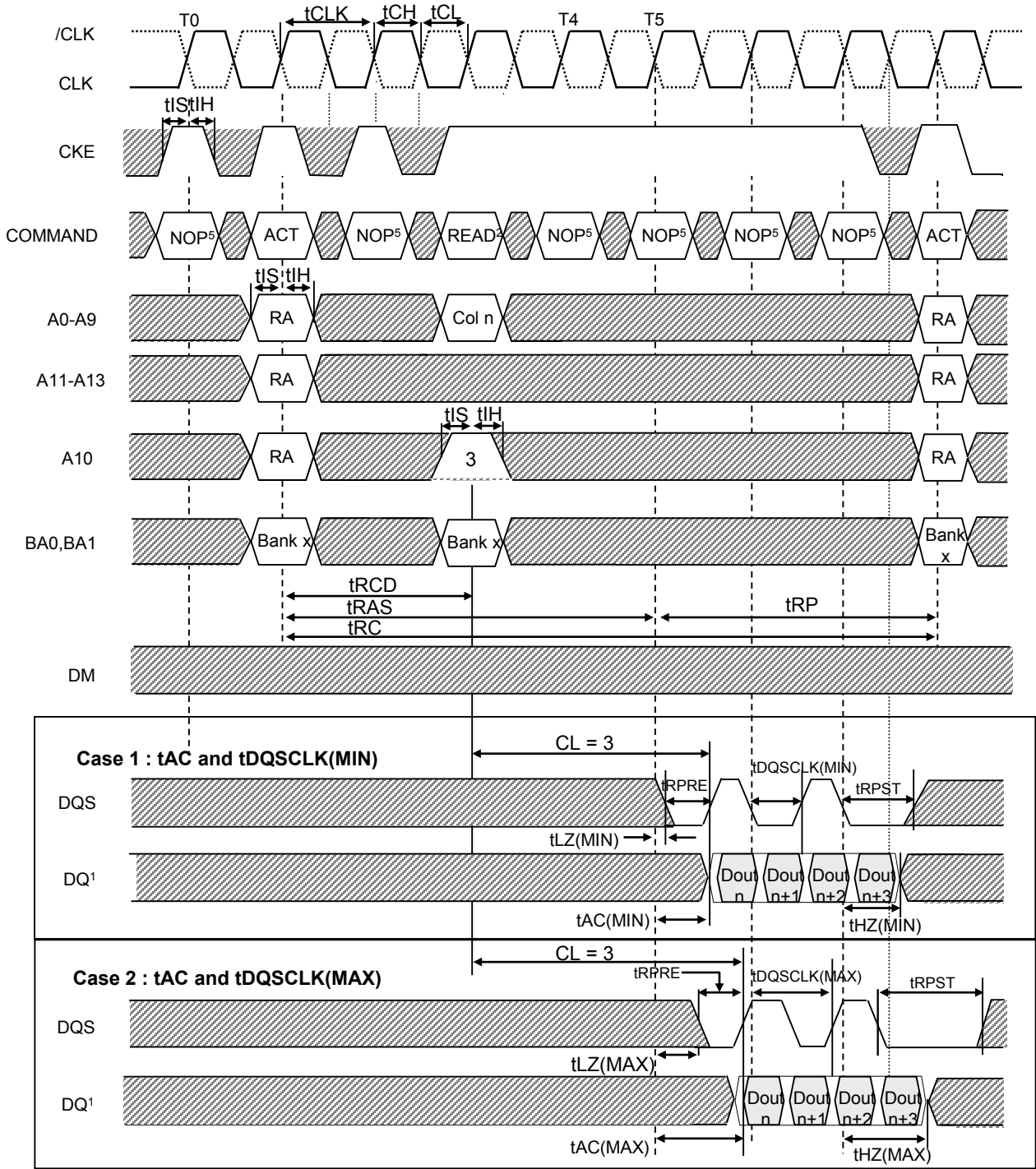
1. Clock must be stable before exiting self refresh mode. That is, the clock must be cycling within specifications by  $Ta0$ .
2. Device must be in the all banks idle state prior to entering self refresh mode.
3. NOPs or DESELECT are required for  $t_{XSR}$  time with at least two clock pulses.
4. AR = AUTO REFRESH command.



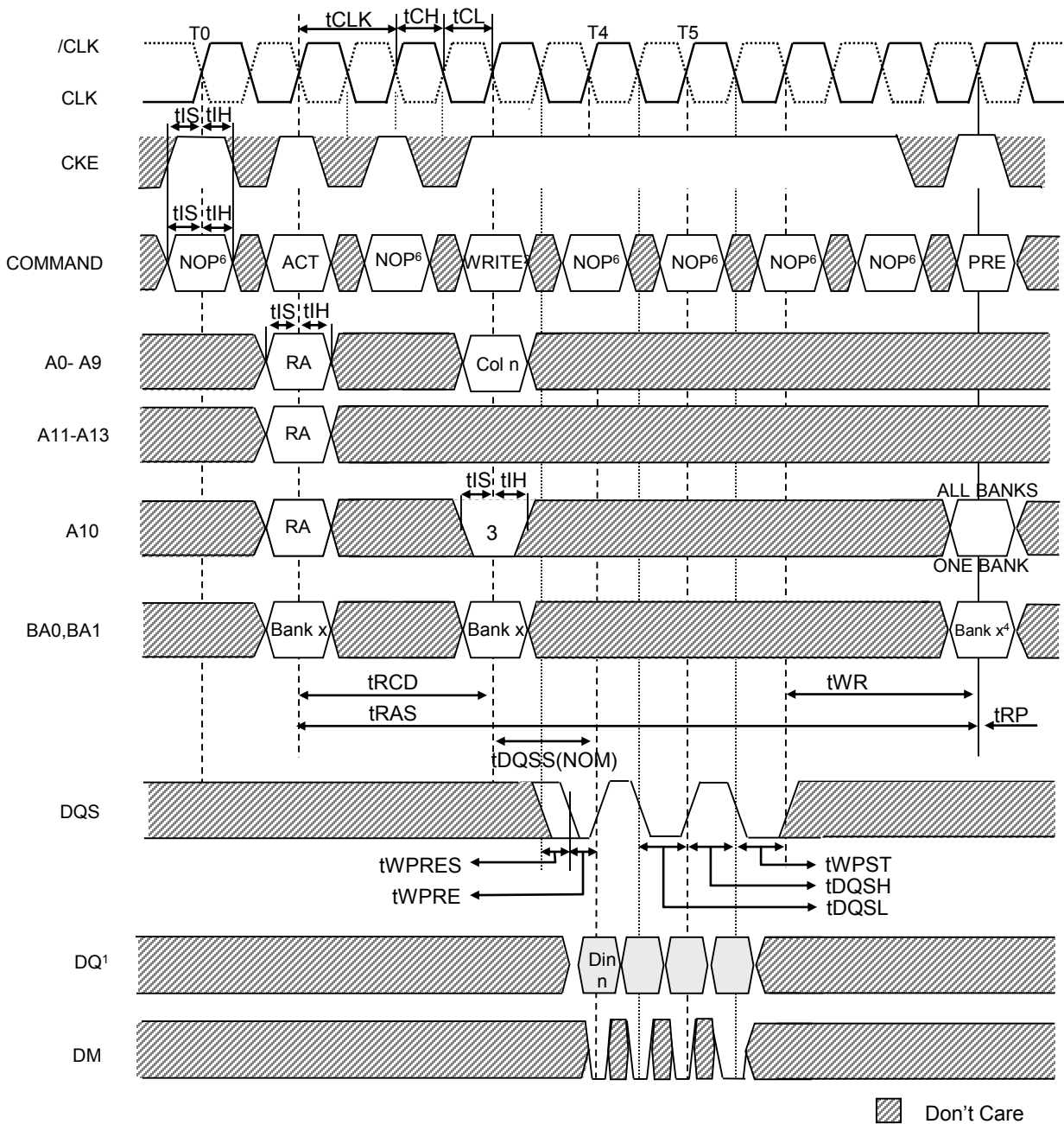
**Figure 33: Bank Read – Without Auto Precharge**

**Notes :**

1. Dout n = data-out from column n.
2. BL = 4 in the case shown.
3. Disable auto precharge.
4. PRE = PRECHARGE, ACT = ACTIVE, RA = Row address, BA = Bank address.
5. NOP commands are shown for ease of illustration; other commands may be valid at these times.
6. The PRECHARGE command can only be applied at T5 if tRAS minimum is met.

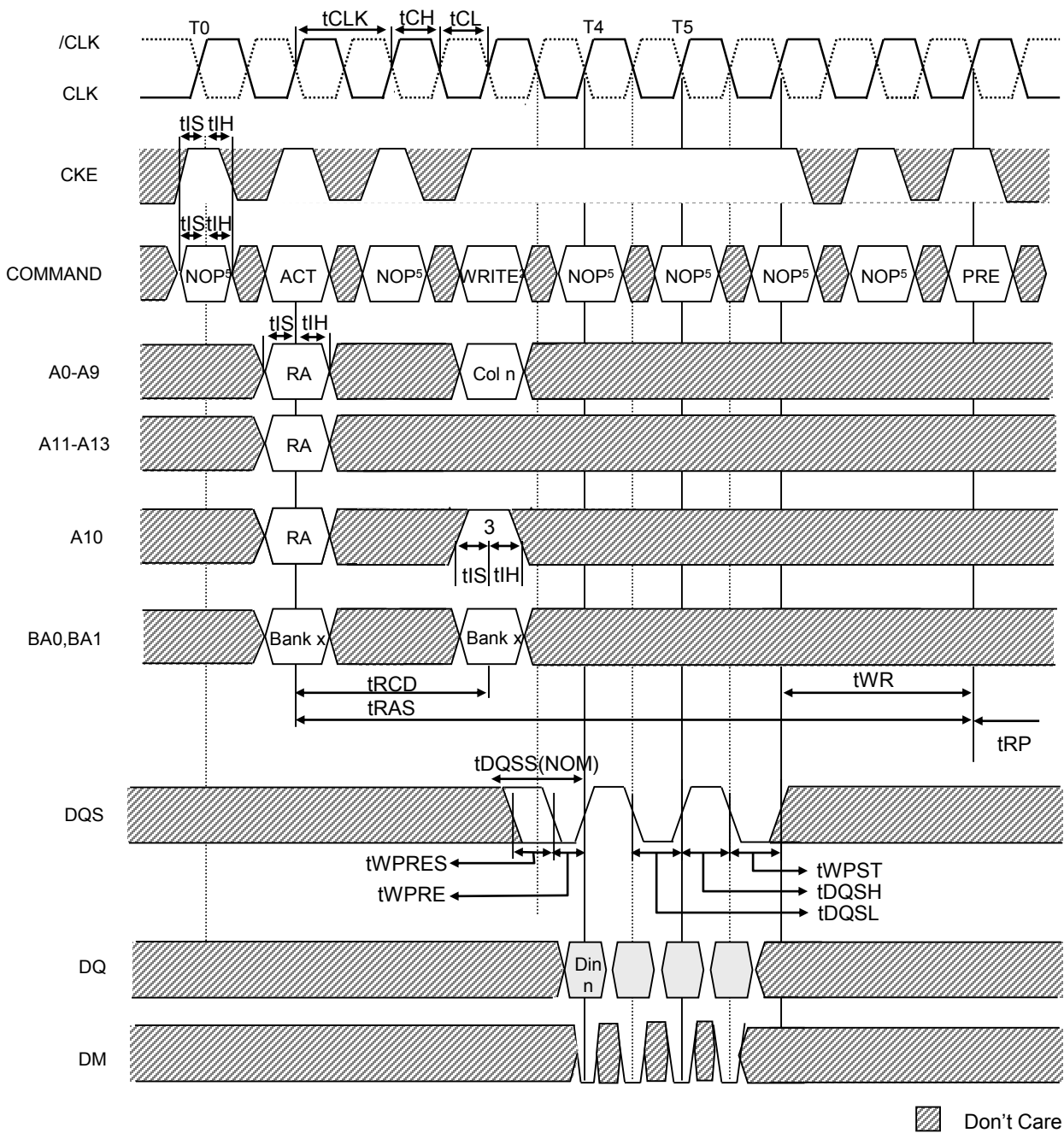
 Don't Care

**Figure 34: Bank Read – With Auto Precharge**

**Notes :**

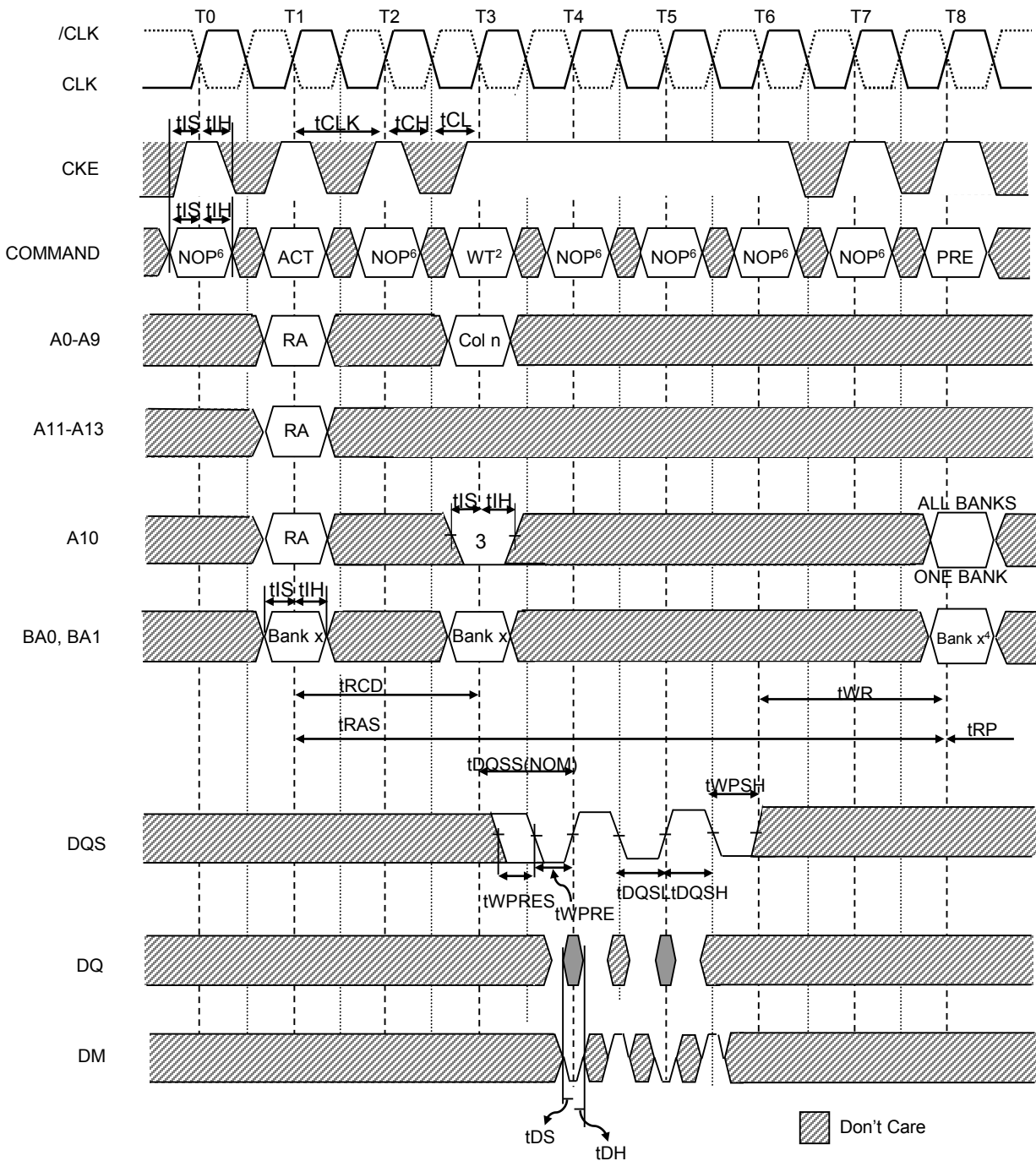
1. Dout n = data-out from column n.
2. BL = 4 in the case shown.
3. Enable auto precharge.
4. PRE = PRECHARGE, ACT = ACTIVE, RA = Row address, BA = Bank address.
5. NOP commands are shown for ease of illustration; other commands may be valid at these times.

**Figure 35: Bank Write – Without Auto Precharge**

**Notes :**

1. Din n = data-in for column n.
2. BL = 4 in the case shown.
3. Disable auto precharge.
4. "Don't Care" if A10 is HIGH at T8.
5. PRE = PRECHARGE, ACT = ACTIVE, RA = Row address, BA = Bank address.
6. NOP commands are shown for ease of illustration; other commands may be valid at these times.
7. tDSH is applicable during tDQSS (MIN) and is referenced from tCLK T4 or T5.
8. tDSH is applicable during tDQSS (MAX) and is referenced from tCLK T5 or T6.

**Figure 36: Bank Write – With Auto Precharge**

**Notes :**

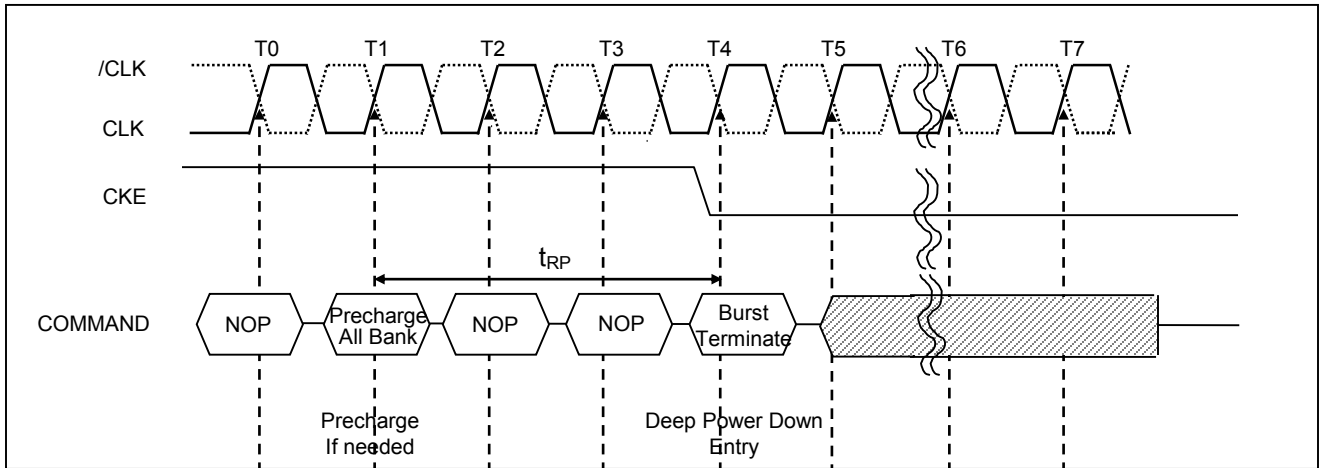
1. Din n = data-in for column n.
2. BL = 4 in the case shown.
3. Enable auto precharge.
4. PRE = PRECHARGE, ACT = ACTIVE, RA = Row address, BA = Bank address.
5. NOP commands are shown for ease of illustration; other commands may be valid at these times.
6. tDSH is applicable during tDQSS (MIN) and is referenced from tCLK T4 or T5.
7. tDSH is applicable during tDQSS (MAX) and is referenced from tCLK T5 or T6.

**Figure 37: Write – DM Operation**

**Notes :**

1. Din n = data-in for column n.
2. BL = 4 in the case shown.
3. Disable auto precharge.
4. "Don't Care" if A10 is HIGH at T8.
5. PRE = PRECHARGE, ACT = ACTIVE, RA = Row address, BA = Bank address.
6. NOP commands are shown for ease of illustration; other commands may be valid at these times.
7. tDSH is applicable during tDQSS (MIN) and is referenced from tCLK T4 or T5.
8. tDSH is applicable during tDQSS (MAX) and is referenced from tCLK T5 or T6.

### DEEP POWER DOWN MODE ENTRY

The Deep Power Down Mode is entered by having burst termination command, while CKE is low. The Deep Power Down Mode has to be maintained for a minimum of 100us. The following diagram illustrates Deep Power Down mode entry.



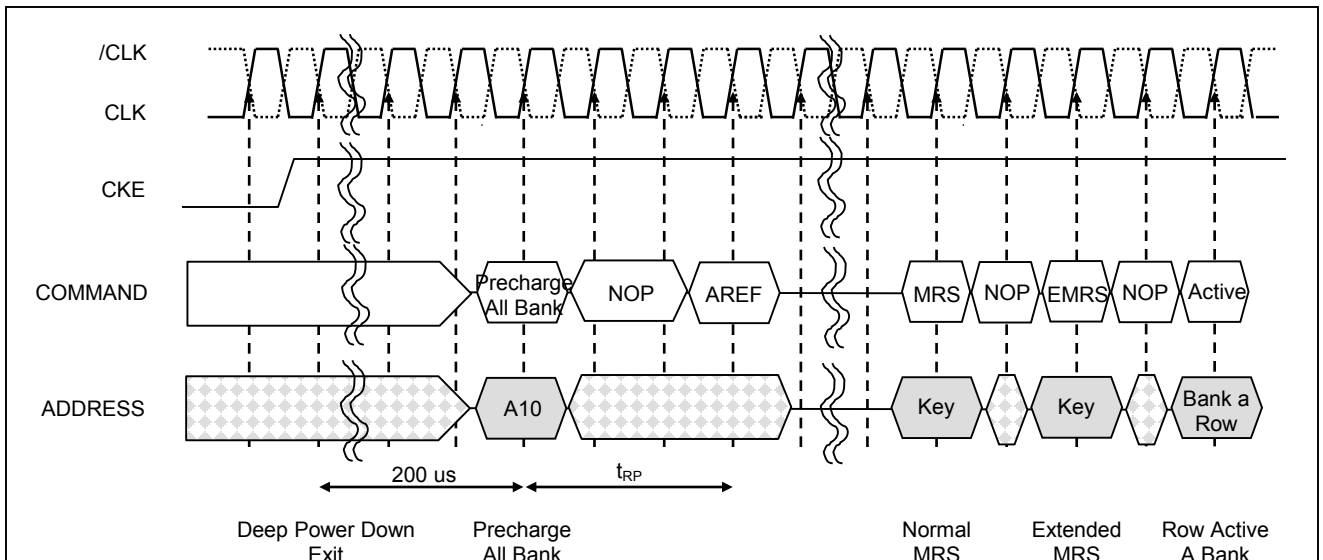
**Figure 38. Deep Power Down Mode Entry**

### DEEP POWER DOWN MODE EXIT SEQUENCE

The Deep Power Down Mode is exited by asserting CKE high. After the exit, the following sequence is needed to enter a new command

1. Maintain NOP input conditions for a minimum of 200us
2. Issue precharge commands for all banks of the device
3. Issue 2 or more auto refresh commands
4. Issue a mode register set command to initialize the mode register
5. Issue a extended mode register set command to initialize the extended mode register

The following timing diagram illustrates deep power down exit sequence

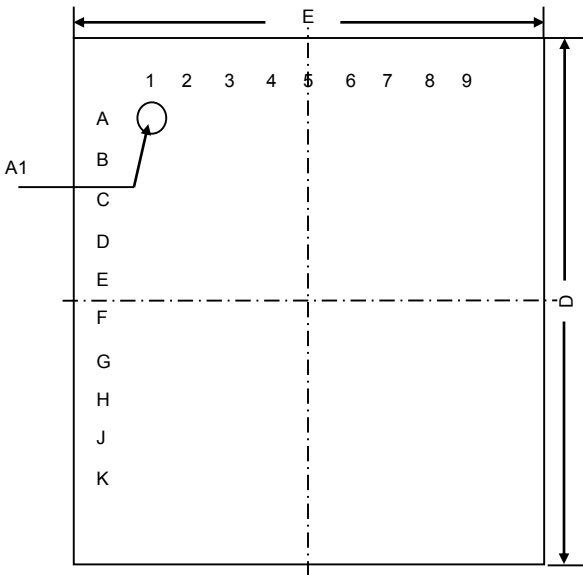


**Figure 39. Deep Power Down Mode Exit**

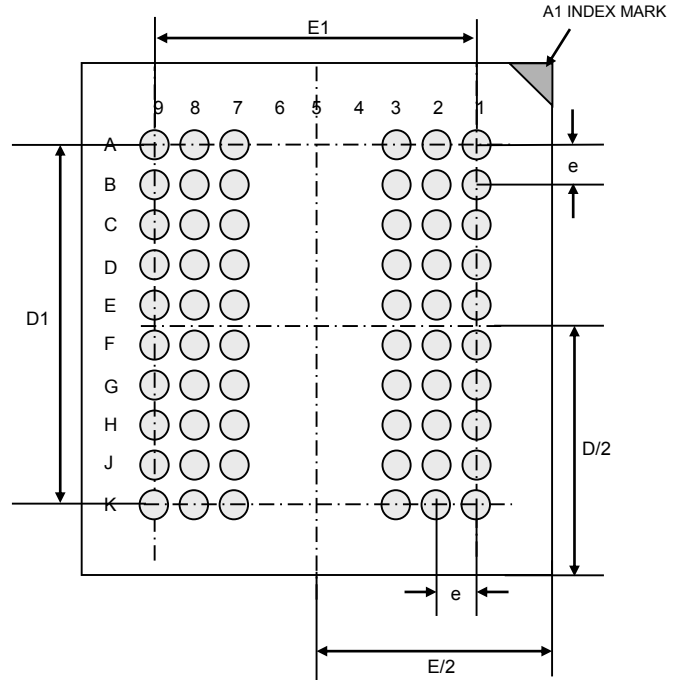
Unit : millimeters

**60 BALL FBGA**

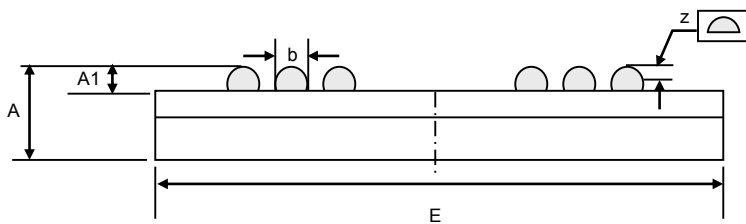
Top View



Bottom View



Side View



Unit : mm

-	Min	Typ	Max
A	-	-	1.00
A1	0.275	0.30	0.325
E	-	8.00	-
E1	-	6.40	-
D	-	9.00	-
D1	-	7.20	-
e	-	0.80	-
b	0.40	0.45	0.50
z	-	-	0.10

**PART NUMBERING SYSTEM**

AS4C	64M16MD1A	5	B	I	N	XX
DRAM	64M16=64Mx16 MD1= Mobile DDR1 A = A die	5=200MHz	B = FBGA	I=Industrial (-40° C~+85° C)	Indicates Pb and Halogen Free	Packing Type None:Tray TR:Reel



Alliance Memory, Inc.  
 511 Taylor Way,  
 San Carlos, CA 94070  
 Tel: 650-610-6800  
 Fax: 650-620-9211  
[www.alliancememory.com](http://www.alliancememory.com)

Copyright © Alliance Memory  
 All Rights Reserved

© Copyright 2007 Alliance Memory, Inc. All rights reserved. Our three-point logo, our name and Intelliwatt are trademarks or registered trademarks of Alliance. All other brand and product names may be the trademarks of their respective companies. Alliance reserves the right to make changes to this document and its products at any time without notice. Alliance assumes no responsibility for any errors that may appear in this document. The data contained herein represents Alliance's best data and/or estimates at the time of issuance. Alliance reserves the right to change or correct this data at any time, without notice. If the product described herein is under development, significant changes to these specifications are possible. The information in this product data sheet is intended to be general descriptive information for potential customers and users, and is not intended to operate as, or provide, any guarantee or warranty to any user or customer. Alliance does not assume any responsibility or liability arising out of the application or use of any product described herein, and disclaims any express or implied warranties related to the sale and/or use of Alliance products including liability or warranties related to fitness for a particular purpose, merchantability, or infringement of any intellectual property rights, except as express agreed to in Alliance's Terms and Conditions of Sale (which are available from Alliance). All sales of Alliance products are made exclusively according to Alliance's Terms and Conditions of Sale. The purchase of products from Alliance does not convey a license under any patent rights, copyrights; mask works rights, trademarks, or any other intellectual property rights of Alliance or third parties. Alliance does not authorize its products for use as critical components in life-supporting systems where a malfunction or failure may reasonably be expected to result in significant injury to the user, and the inclusion of Alliance products in such life-supporting systems implies that the manufacturer assumes all risk of such use and agrees to indemnify Alliance against all claims arising from such use.



Компания «Life Electronics» занимается поставками электронных компонентов импортного и отечественного производства от производителей и со складов крупных дистрибьюторов Европы, Америки и Азии.

С конца 2013 года компания активно расширяет линейку поставок компонентов по направлению коаксиальный кабель, кварцевые генераторы и конденсаторы (керамические, пленочные, электролитические), за счёт заключения дистрибьюторских договоров

Мы предлагаем:

- Конкурентоспособные цены и скидки постоянным клиентам.
- Специальные условия для постоянных клиентов.
- Подбор аналогов.
- Поставку компонентов в любых объемах, удовлетворяющих вашим потребностям.
- Приемлемые сроки поставки, возможна ускоренная поставка.
- Доставку товара в любую точку России и стран СНГ.
- Комплексную поставку.
- Работу по проектам и поставку образцов.
- Формирование склада под заказчика.
- Сертификаты соответствия на поставляемую продукцию (по желанию клиента).
- Тестирование поставляемой продукции.
- Поставку компонентов, требующих военную и космическую приемку.
- Входной контроль качества.
- Наличие сертификата ISO.

В составе нашей компании организован Конструкторский отдел, призванный помогать разработчикам, и инженерам.

Конструкторский отдел помогает осуществить:

- Регистрацию проекта у производителя компонентов.
- Техническую поддержку проекта.
- Защиту от снятия компонента с производства.
- Оценку стоимости проекта по компонентам.
- Изготовление тестовой платы монтаж и пусконаладочные работы.



Тел: +7 (812) 336 43 04 (многоканальный)

Email: [org@lifeelectronics.ru](mailto:org@lifeelectronics.ru)