

# Analog Devices Welcomes Hittite Microwave Corporation

NO CONTENT ON THE ATTACHED DOCUMENT HAS CHANGED



**THIS PAGE INTENTIONALLY LEFT BLANK**

## 400° ANALOG PHASE SHIFTER 5 - 18 GHz

### Typical Applications

The HMC247 is ideal for:

- Fiber Optics
- Military
- Test Equipment

### Features

- Wide Bandwidth: 5 - 18 GHz
- Phase Shift: >400°
- Single Positive Voltage Control
- Small Size: 2.3 x 1.6 x 0.1 mm

### Functional Diagram

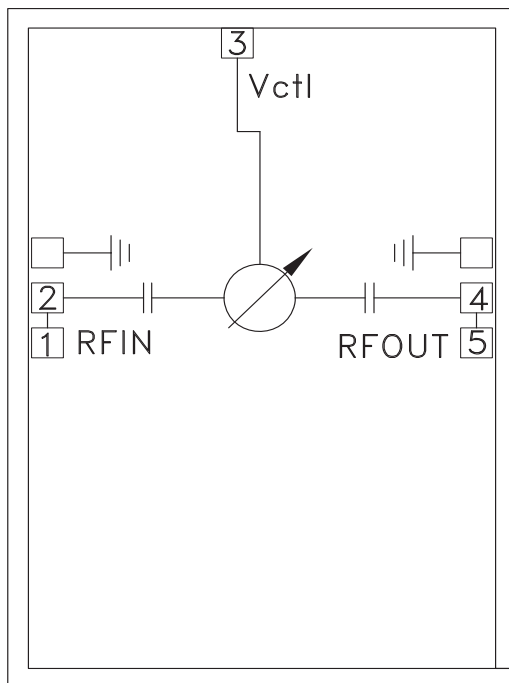

### General Description

The HMC247 is an Analog Phase Shifter die which is controlled via an analog control voltage from 0 to +10V. The HMC247 provides a continuously variable phase shift of 0 to 300 degrees at 9 GHz, and 0 to 100 degrees at 18 GHz, with consistent insertion loss versus phase shift. The phase shift is monotonic with respect to the control voltage. The control port has a modulation bandwidth of 50 MHz. The low insertion loss and compact size enable this part to be used in a wide range of applications, including the phase adjustment of clocks in fiber optic systems and test equipment. All data is measured with the chip in a 50 ohm test fixture, connected via 0.076 mm (3 mil) ribbon bonds of minimal length <0.31 mm (<12 mils).

### Electrical Specifications, $T_A = +25^\circ \text{C}$ , 50 Ohm System

Parameter	Frequency (GHz)	Min.	Typ.	Max.	Units
Phase Shift Range:	5 - 10 GHz	180	400		degrees
	10 - 13 GHz	135	200		degrees
	13 - 18 GHz	45	120		degrees
Insertion Loss	5 - 10 GHz		8	12	dB
	10 - 18 GHz		4	7	dB
Return Loss (Input and Output)	5 - 18 GHz		8		dB
Control Voltage Range	5 - 18 GHz		0 - 10		Volt
Modulation Bandwidth	5 - 18 GHz		50		MHz
Phase Voltage Sensitivity	5 - 18 GHz		40		deg / Volt
Insertion Phase Temperature Sensitivity	5 - 18 GHz		0.5		deg / °C

**400° ANALOG PHASE SHIFTER  
5 - 18 GHz**

**Insertion Loss vs. Control Voltage @ 12 GHz**

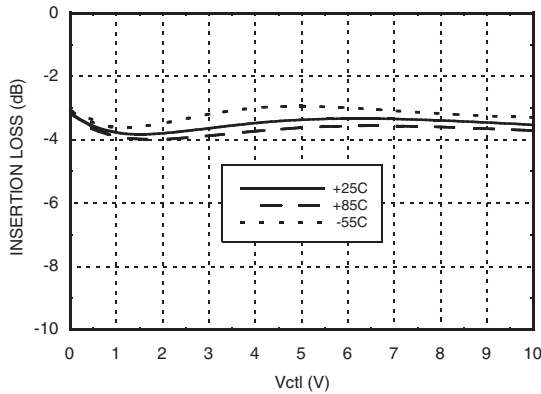

**Phase Shift vs. Control Voltage**

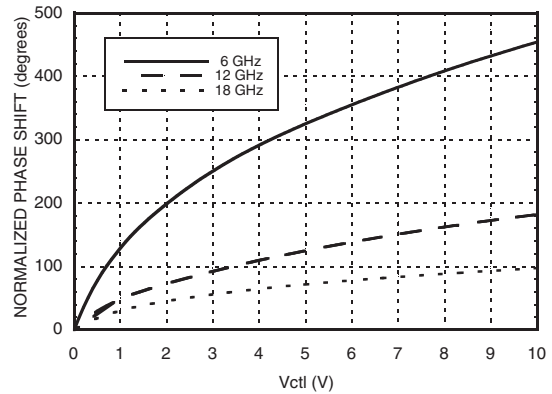

**Phase Shift vs. Frequency @ Vctl = 10V  
(Relative to Vctl = 0V)**

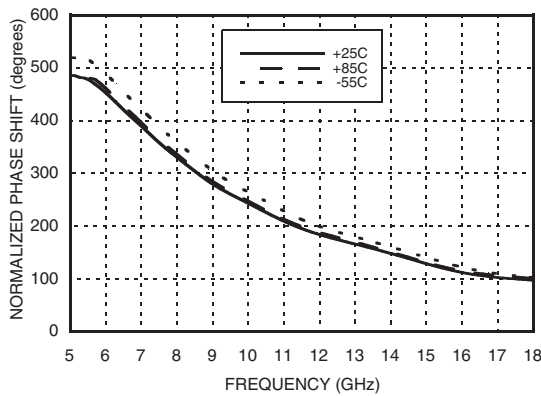

**Insertion Loss vs. Frequency**

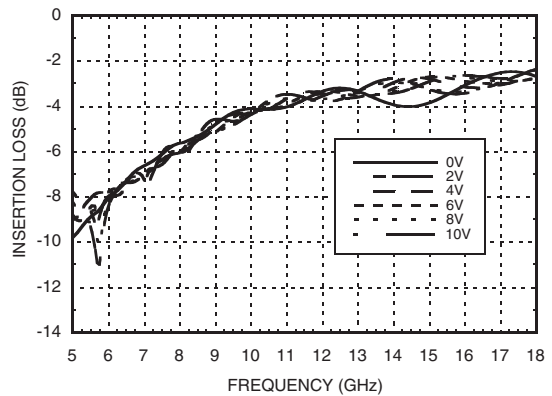

**Input Return Loss vs. Frequency,  
Vctl = 0 to +10V**

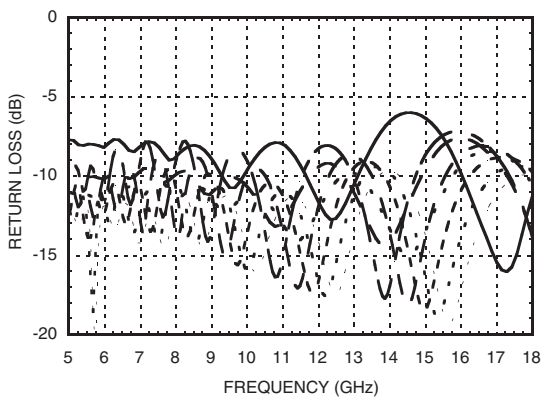

**Output Return Loss vs. Frequency,  
Vctl = 0 to +10V**

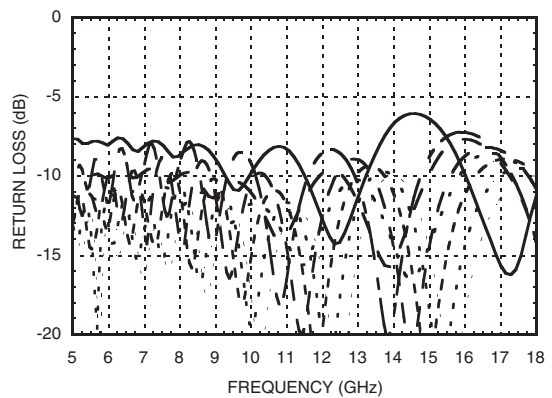

**400° ANALOG PHASE SHIFTER  
5 - 18 GHz**

**Second Harmonics vs. Control Voltage, Pin = -10 dBm**

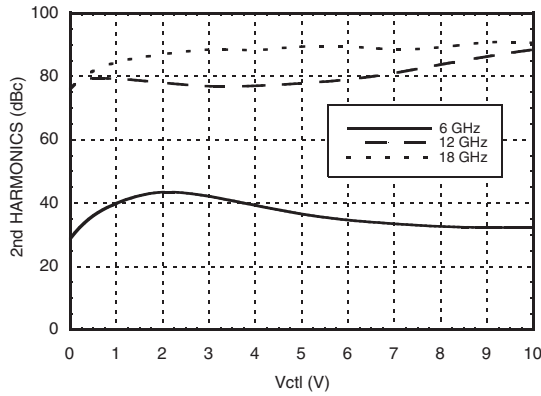

**Input IP3 vs. Control Voltage**

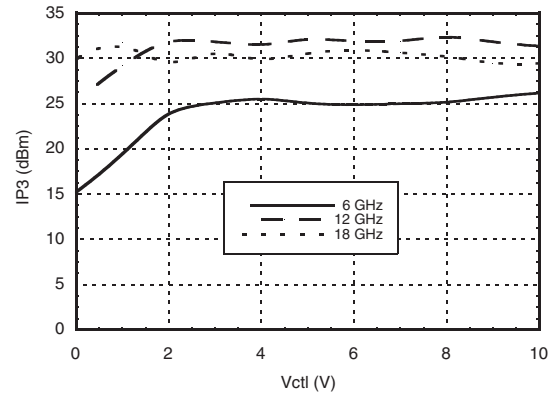

**Insertion Loss vs. Pin @ 7 GHz**

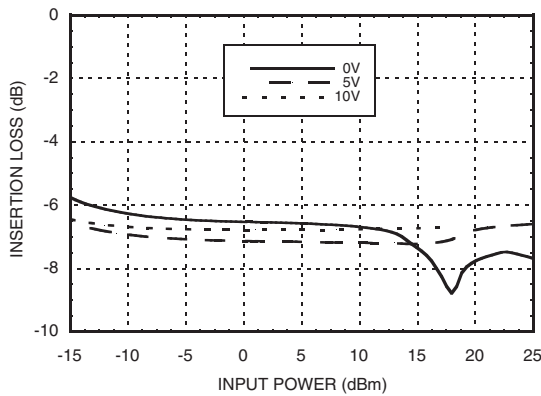

**Insertion Loss vs. Pin @ 12 GHz**

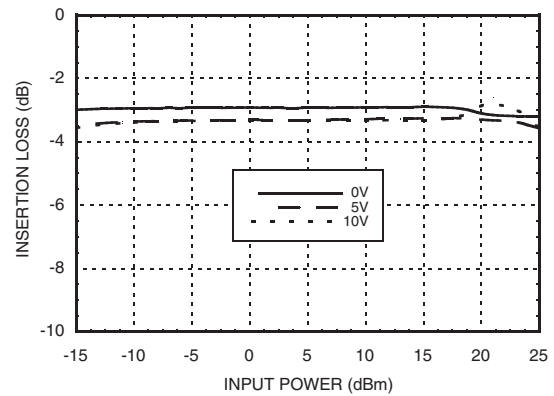

**Insertion Loss vs. Pin @ 18 GHz**

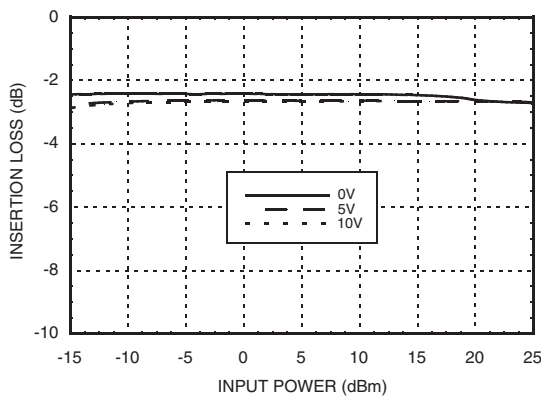

**Phase Shift vs. Pin @ 7 GHz**

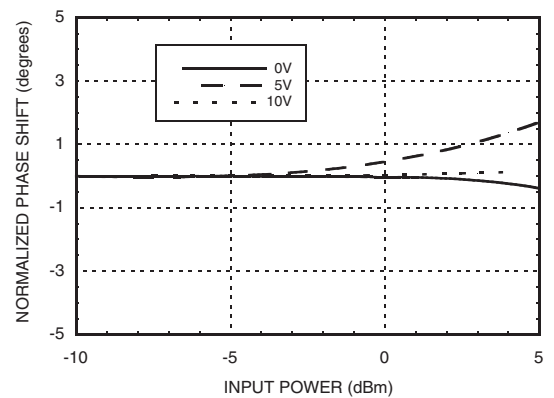

**400° ANALOG PHASE SHIFTER  
5 - 18 GHz**

**Phase Shift vs. Pin @ 12 GHz**

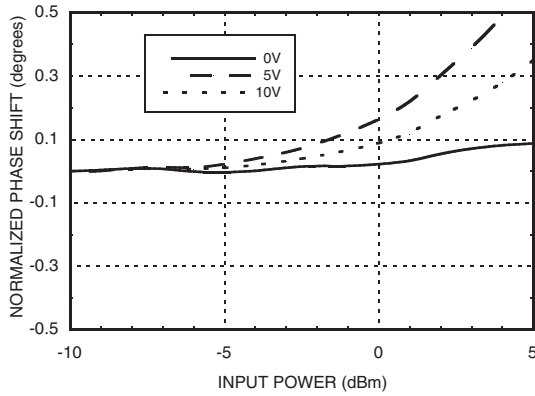

**Phase Shift vs. Pin @ 18 GHz**

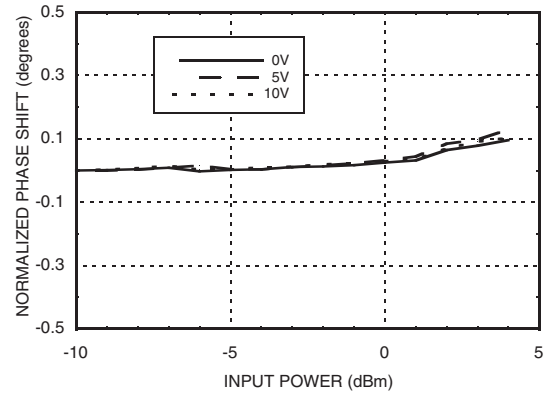



**Absolute Maximum Ratings**

Control Voltage (Vctl)	+11 Vdc
Reverse Current	5 mA
Input Power (RFin)	+30 dBm
Channel Temperature (Tc)	150 °C
Continuous P <sub>diss</sub> (T = 85 °C) (derate 28 mW/°C above 85 °C)	1.83 W
Thermal Resistance (junction to die bottom)	35.6 °C/W
Storage Temperature	-65 to +150 °C
Operating Temperature	-55 to +85 °C

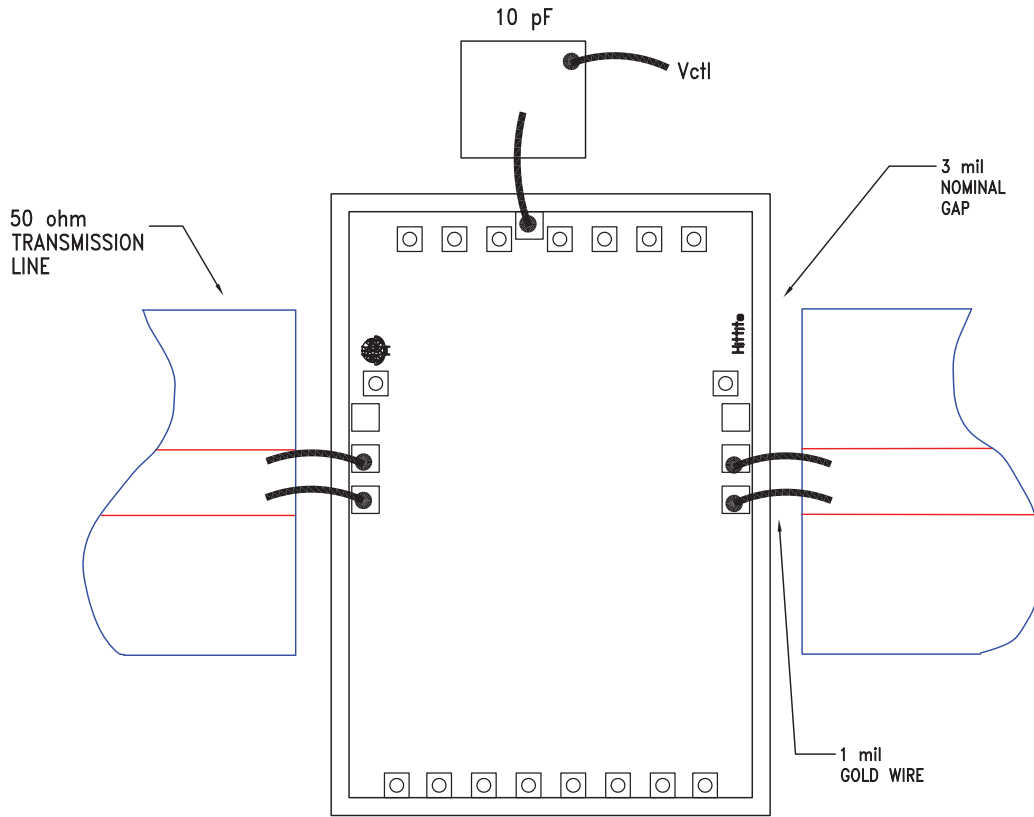
### Assembly Diagram

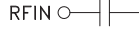
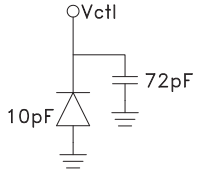
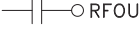

### Pad Descriptions

Pad Number	Function	Description	Interface Schematic
1, 2	RFIN	Port is DC blocked.	RFIN 
3	Vctl	Phase shift control pin. Application of voltage between 0 and 10 volts causes the transmission phase to change. The DC equivalent circuit is a series connected diode resistor	
4, 5	RFOUT	Port is DC blocked.	 RFOUT
	GND	The backside of the die must be connected to RF / DC ground.	

**Outline Drawing**

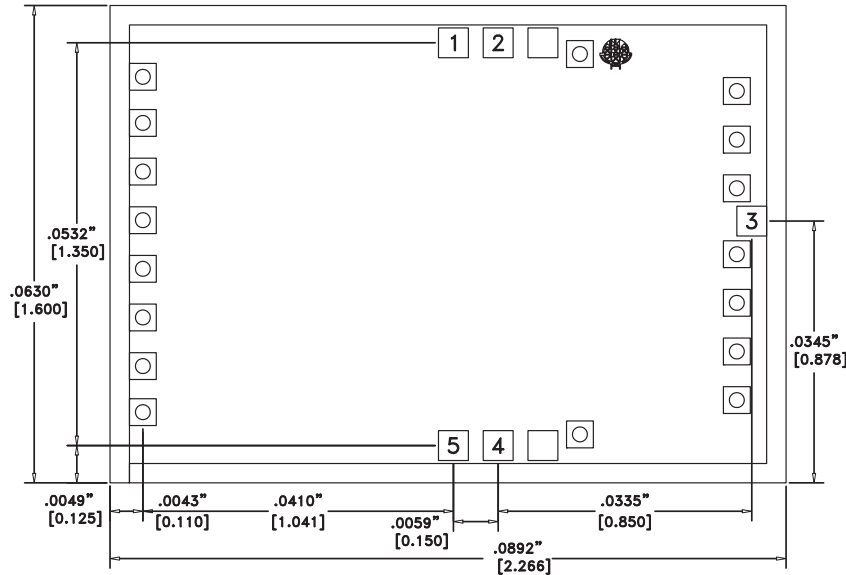

**Die Packaging Information** [1]

Standard	Alternate
WP-4 (Waffle Pack)	[2]

[1] Refer to the "Packaging Information" section for die packaging dimensions.

[2] For alternate packaging information contact Hittite Microwave Corporation.

1. ALL DIMENSIONS ARE IN INCHES [MM]
2. TIE ALL UNLABELED BOND PADS TO GROUND.
3. DIE THICKNESS IS .004"
4. TYPICAL BOND PAD IS .004" SQUARE.
5. BACKSIDE METALIZATION: GOLD.
6. BOND PAD METALIZATION: GOLD.

**Handling Precautions**

Follow these precautions to avoid permanent damage.

**Storage:** All bare die are placed in either Waffle or Gel based ESD protective containers, and then sealed in an ESD protective bag for shipment. Once the sealed ESD protective bag has been opened, all die should be stored in a dry nitrogen environment.

**Cleanliness:** Handle the chips in a clean environment. DO NOT attempt to clean the chip using liquid cleaning systems.

**Static Sensitivity:** Follow ESD precautions to protect against ESD strikes.

**Transients:** Suppress instrument and bias supply transients while bias is applied. Use shielded signal and bias cables to minimize inductive pick-up.

**General Handling:** Handle the chip along the edges with a vacuum collet or with a sharp pair of bent tweezers. The surface of the chip has fragile air bridges and should not be touched with vacuum collet, tweezers, or fingers.

**Mounting**

The chip is back-metallized and can be die mounted with electrically conductive epoxy. The mounting surface should be clean and flat.

**Epoxy Die Attach:** Apply a minimum amount of epoxy to the mounting surface so that a thin epoxy fillet is observed around the perimeter of the chip once it is placed into position. Cure epoxy per the manufacturer's schedule.

**Wire Bonding**

Ball or wedge bond with 0.025mm (1 mil) diameter pure gold wire. Thermosonic wirebonding with a nominal stage temperature of 150 deg. C and a ball bonding force of 40 to 50 grams or wedge bonding force of 18 to 22 grams is recommended. Use the minimum level of ultrasonic energy to achieve reliable wirebonds. Wirebonds should be started on the chip and terminated on the package or substrate. All bonds should be as short as possible <0.31mm (12 mils).

For price, delivery, and to place orders, please contact Hittite Microwave Corporation:  
20 Alpha Road, Chelmsford, MA 01824 Phone: 978-250-3343 Fax: 978-250-3373  
Order On-line at [www.hittite.com](http://www.hittite.com)



Компания «Life Electronics» занимается поставками электронных компонентов импортного и отечественного производства от производителей и со складов крупных дистрибьюторов Европы, Америки и Азии.

С конца 2013 года компания активно расширяет линейку поставок компонентов по направлению коаксиальный кабель, кварцевые генераторы и конденсаторы (керамические, пленочные, электролитические), за счёт заключения дистрибьюторских договоров

Мы предлагаем:

- Конкурентоспособные цены и скидки постоянным клиентам.
- Специальные условия для постоянных клиентов.
- Подбор аналогов.
- Поставку компонентов в любых объемах, удовлетворяющих вашим потребностям.
- Приемлемые сроки поставки, возможна ускоренная поставка.
- Доставку товара в любую точку России и стран СНГ.
- Комплексную поставку.
- Работу по проектам и поставку образцов.
- Формирование склада под заказчика.
- Сертификаты соответствия на поставляемую продукцию (по желанию клиента).
- Тестирование поставляемой продукции.
- Поставку компонентов, требующих военную и космическую приемку.
- Входной контроль качества.
- Наличие сертификата ISO.

В составе нашей компании организован Конструкторский отдел, призванный помогать разработчикам, и инженерам.

Конструкторский отдел помогает осуществить:

- Регистрацию проекта у производителя компонентов.
- Техническую поддержку проекта.
- Защиту от снятия компонента с производства.
- Оценку стоимости проекта по компонентам.
- Изготовление тестовой платы монтаж и пусконаладочные работы.



Тел: +7 (812) 336 43 04 (многоканальный)  
Email: [org@lifeelectronics.ru](mailto:org@lifeelectronics.ru)