

NHD-C12864KGZ-FSW-GBW

COG (Chip-On-Glass) Liquid Crystal Display Module

NHD- Newhaven Display
C12864- 128 x 64 Pixels
KGZ- Model
F- Transflective
SW- Side White LED Backlight
G- STN - Gray
B- 6:00 Optimal View
W- Wide Temperature
RoHS Compliant

Newhaven Display International, Inc.

2661 Galvin Court,

Elgin IL, 60124

Ph: 847-844-8795

Fax: 847-844-8796

www.newhavendisplay.com

nhtech@newhavendisplay.com

nhsales@newhavendisplay.com

Document Revision History

Revision	Date	Description	Changed by
0	3/19/2012	Initial Release	-
1	5/11/2012	Electrical and Optical characteristics updated	AK
2	4/4/2013	Backlight mating connector part number updated	AK
3	10/3/2013	Example Code updated	ML

Functions and Features

- 128 x 64 pixels
- Built-in ST7565R controller
- 1/65 duty, 1/9 bias
- Parallel 8080 MPU interface
- RoHS Compliant

Mechanical Drawing

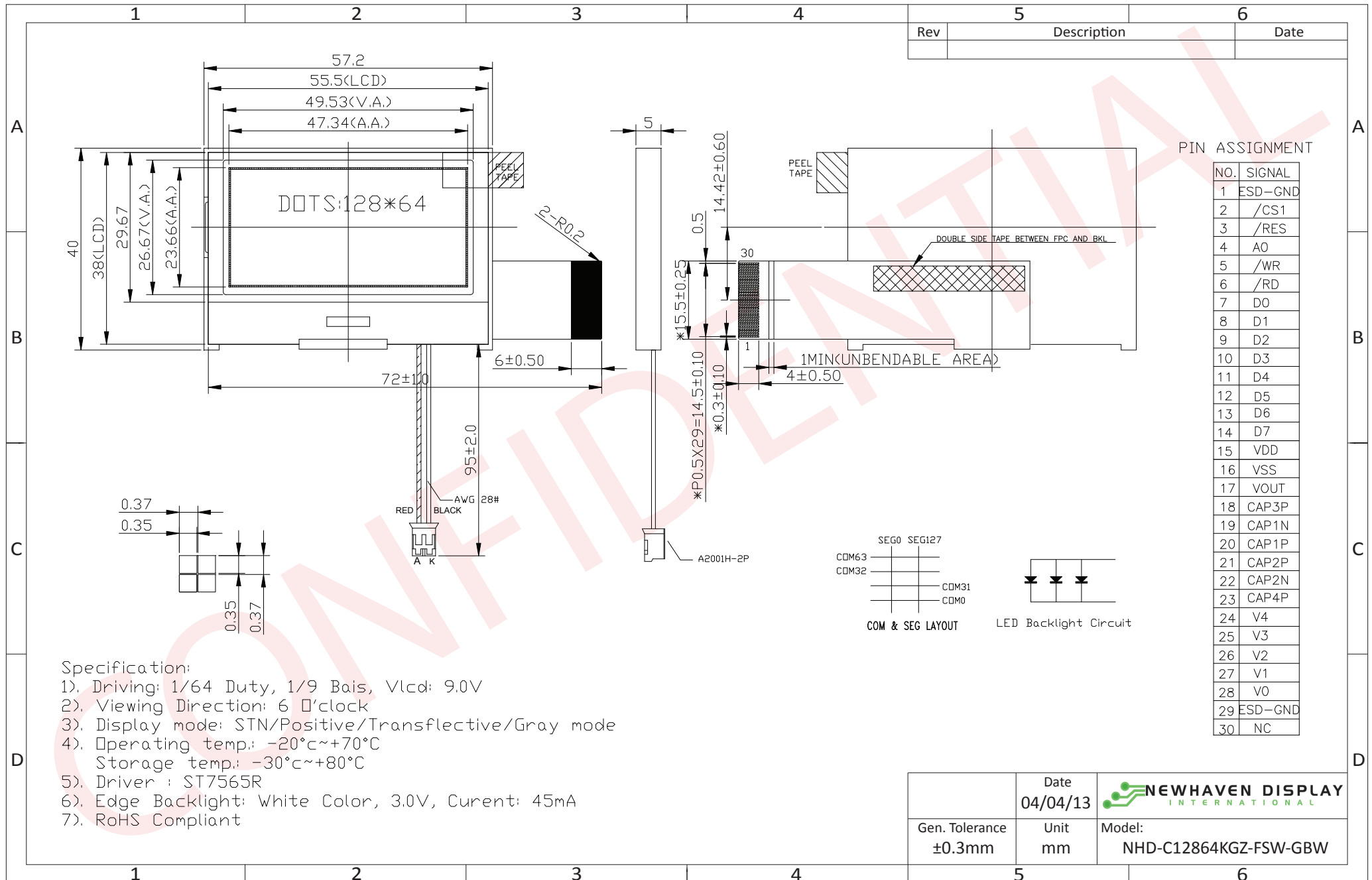

The drawing contained herein is the exclusive property of Newhaven Display International, Inc. and shall not be copied, reproduced, and/or disclosed in any format without permission.

Pin Description and Wiring Diagram

Pin No.	Symbol	External Connection	Function Description
1	ESD-GND	Power Supply	Ground (can be a No Connect)
2	/CS1	MPU	Active LOW Chip Select signal
3	/RES	MPU	Active LOW Reset signal
4	A0	MPU	Register Select: '0' = Command, '1' = Data
5	/WR	MPU	Active LOW Write signal
6	/RD	MPU	Active LOW Read signal
7-14	D0-D7	MPU	8-bit bi-directional data bus
15	VDD	Power Supply	Supply Voltage for LCD and Logic (3.0V)
16	VSS	Power Supply	Ground
17	VOUT	Power Supply	1.0uF-2.2uF cap to VSS
18	C3+	Power Supply	1.0uF-2.2uF cap to C1- (Pin-19)
19	C1-	Power Supply	1.0uF-2.2uF cap to C3+ (Pin-18) and C1+ (Pin-20)
20	C1+	Power Supply	1.0uF-2.2uF cap to C1- (Pin-19)
21	C2+	Power Supply	1.0uF-2.2uF cap to C2- (Pin-22)
22	C2-	Power Supply	1.0uF-2.2uF cap to C2+(Pin-21) and C4+ (Pin-23)
23	C4+	Power Supply	1.0uF-2.2uF cap to C2- (Pin-22)
24	V4	Power Supply	0.1uF-1.0uF cap to VDD or VSS
25	V3	Power Supply	0.1uF-1.0uF cap to VDD or VSS
26	V2	Power Supply	0.1uF-1.0uF cap to VDD or VSS
27	V1	Power Supply	0.1uF-1.0uF cap to VDD or VSS
28	V0	Power Supply	0.1uF-1.0uF cap to VDD or VSS
29	ESD-GND	Power Supply	Ground (can be a No Connect)
30	NC	-	No Connect

Recommended LCD connector: 0.5mm pitch, 30 conductor FFC. Molex p/n: 52892-3095

Backlight connector: A2001H-2P **Mates with:** A2001WR-2P, A2001WR-S-2P, A2001WV-2P, A2001WV-S-2P

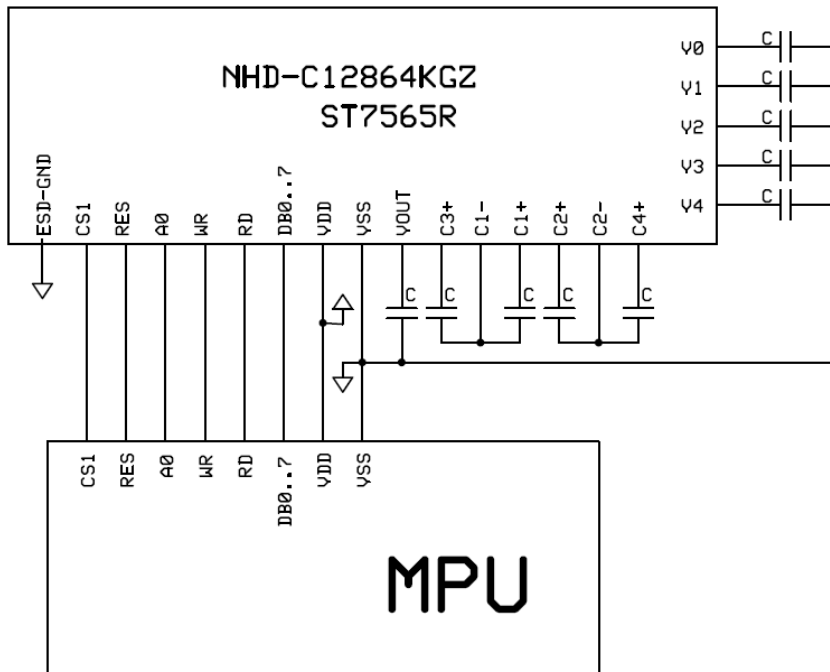

Electrical Characteristics

Item	Symbol	Condition	Min.	Typ.	Max.	Unit
Operating Temperature Range	Top	Absolute Max	-20	-	+70	°C
Storage Temperature Range	Tst	Absolute Max	-30	-	+80	°C
Supply Voltage	VDD	-	3.0	3.0	3.3	V
Supply Current	IDD	Ta=25°C,VDD=3.0V	-	0.5	-	mA
Supply for LCD (contrast)	VDD-V0	Ta =25°C	-	9.0	-	V
"H" Level input	Vih	-	0.8*VDD	-	VDD	V
"L" Level input	Vil	-	VSS	-	0.2*VDD	V
"H" Level output	Voh	-	0.8*VDD	-	VDD	V
"L" Level output	Vol	-	VSS	-	0.2*VDD	V
Backlight Supply Voltage	VLED	-	3.0	-	3.2	V
Backlight Supply Current	ILED	VLED=3.0V	-	45	-	mA

Optical Characteristics

Item	Symbol	Condition	Min.	Typ.	Max.	Unit
Viewing Angle – Top		CR ≥ 2	-	25	-	°
Viewing Angle – Bottom			-	45	-	°
Viewing Angle – Left			-	30	-	°
Viewing Angle – Right			-	30	-	°
Contrast Ratio	CR		3	4	-	-
Response Time (rise)	Tr		-	250	300	ms
Response Time (fall)	Tf		-	250	350	ms

Controller Information

Built-in ST7565R controller.

Please download specification at http://www.newhavendisplay.com/app_notes/ST7565R.pdf

Timing Characteristics

8080 MPU Interface (VDD=3.3V)

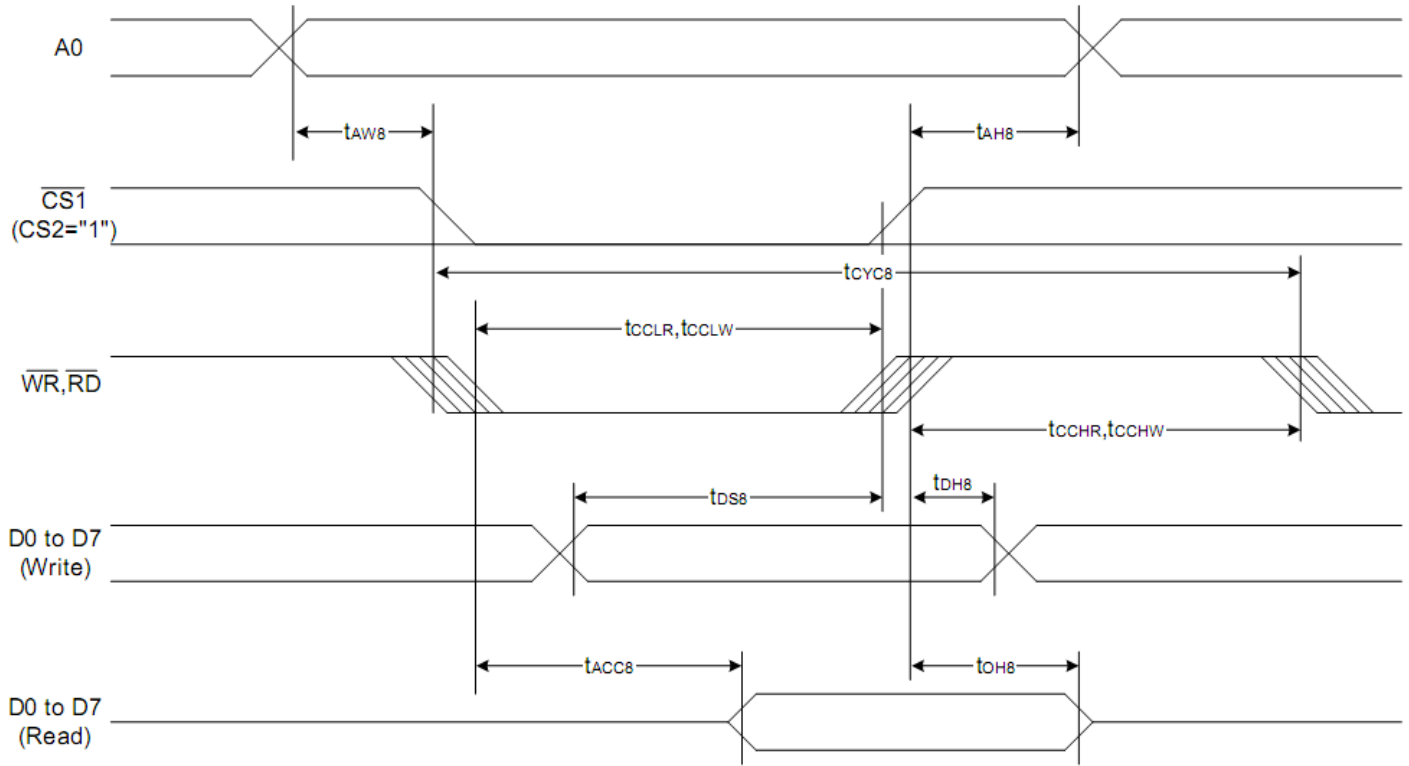

Item	Signal	Symbol	Condition	Rating		Units
				Min.	Max.	
Address hold time	A0	t_{AH8}		0	—	Ns
Address setup time		t_{AW8}		0	—	
System cycle time		t_{CYC8}		240	—	
Enable L pulse width (WRITE)	WR	t_{CCLW}		80	—	
Enable H pulse width (WRITE)		t_{CCHR}		80	—	
Enable L pulse width (READ)	RD	t_{CCLR}		140	—	
Enable H pulse width (READ)		t_{CCHR}		80	—	
WRITE Data setup time	D0 to D7	t_{DS8}		40	—	
WRITE Address hold time		t_{DH8}		0	—	
READ access time		t_{ACC8}	$C_L = 100 \text{ pF}$	—	70	
READ Output disable time		t_{OH8}	$C_L = 100 \text{ pF}$	5	50	

Table of Commands

Command	Command Code									Function			
	A0	/RD	/WR	D7	D6	D5	D4	D3	D2		D1	D0	
(1) Display ON/OFF	0	1	0	1	0	1	0	1	1	1	0	1	LCD display ON/OFF 0: OFF, 1: ON
(2) Display start line set	0	1	0	0	1	Display start address					0	Sets the display RAM display start line address	
(3) Page address set	0	1	0	1	0	1	Page address				0	Sets the display RAM page address	
(4) Column address set upper bit	0	1	0	0	0	0	1	Most significant column address			0	Sets the most significant 4 bits of the display RAM column address.	
Column address set lower bit				0	0	0	0	Least significant column address			0	Sets the least significant 4 bits of the display RAM column address.	
(5) Status read	0	0	1	Status			0	0	0	0	0	Reads the status data	
(6) Display data write	1	1	0	Write data						0	Writes to the display RAM		
(7) Display data read	1	0	1	Read data						0	Reads from the display RAM		
(8) ADC select	0	1	0	1	0	1	0	0	0	0	0	1	Sets the display RAM address SEG output correspondence 0: normal, 1: reverse
(9) Display normal/reverse	0	1	0	1	0	1	0	0	1	1	0	1	Sets the LCD display normal/ reverse 0: normal, 1: reverse
(10) Display all points ON/OFF	0	1	0	1	0	1	0	0	1	0	0	1	Display all points 0: normal display 1: all points ON
(11) LCD bias set	0	1	0	1	0	1	0	0	0	1	0	1	Sets the LCD drive voltage bias ratio 0: 1/9 bias, 1: 1/7 bias (ST7565R)
(12) Read-modify-write	0	1	0	1	1	1	0	0	0	0	0	0	Column address increment At write: +1 At read: 0
(13) End	0	1	0	1	1	1	0	1	1	1	0	0	Clear read/modify/write
(14) Reset	0	1	0	1	1	1	0	0	0	0	1	0	Internal reset
(15) Common output mode select	0	1	0	1	1	0	0	0	*	*	*	*	Select COM output scan direction 0: normal direction 1: reverse direction
(16) Power control set	0	1	0	0	0	1	0	1	Operating mode		0	0	Select internal power supply operating mode
(17) V ₀ voltage regulator internal resistor ratio set	0	1	0	0	0	1	0	0	Resistor ratio		0	0	Select internal resistor ratio(Rb/Ra) mode
(18) Electronic volume mode set	0	1	0	1	0	0	0	0	0	0	0	1	Set the V ₀ output voltage electronic volume register
Electronic volume register set				0	0	Electronic volume value					0		
(19) Sleep mode set	0	1	0	1	0	1	0	1	1	0	0	1	0: Sleep mode, 1: Normal mode
(20) Booster ratio set	0	1	0	1	1	1	1	1	0	0	0	0	select booster ratio 00: 2x,3x,4x 01: 5x 11: 6x
				0	0	0	0	0	0	0	step-up value		
(21) NOP	0	1	0	1	1	1	0	0	0	0	1	1	Command for non-operation
(22) Test	0	1	0	1	1	1	1	*	*	*	*	*	Command for IC test. Do not use this command

Example Initialization Code

```
/**
 *
 */

void comm_out(unsigned char c)
{
    CS1 = 0;
    AO = 0;           //LOW = command
    WRT = 0;
    P1 = c;
    WRT = 1;
    CS1 = 1;
}

/**
 *
 */

void data_out(unsigned char d)
{
    CS1 = 0;
    AO = 1;           //HIGH = data
    WRT = 0;
    P1 = d;
    WRT = 1;
    CS1 = 1;
}

/**
 *
 */

void disp()
{
    unsigned int i, j;
    unsigned char page=0xB0;
    for(i=0;i<8;i++)           //fill display with checkerboard pattern
    {
        comm_out(0x10);       //set column address
        comm_out(0x00);       //set column address
        comm_out(page);       //set page address
        for(j=0;j<64;j++)
        {
            data_out(0xAA);
            data_out(0x55);
        }
        page++;
    }
}

/**
 *
 */
```



```

/*****
/***** NHD-C12864KGZ DISPLAY INITIALIZATION *****/
/*****

void init()
{
    RDD = 1;
    WRT = 1;
    CS1 = 0;
    RST = 0;
    delay(150);
    RST = 1;
    delay(150);

    comm_out(0xA2); //added 1/9 bias
    comm_out(0xA0); //ADC segment driver direction (A0=Normal)
    comm_out(0xC0); //COM output scan direction (C0=Normal)
    comm_out(0x25); //resistor ratio
    comm_out(0x81); //electronic volume mode set
    comm_out(0x15); //electronic volume register set
    comm_out(0x2F); //operating mode
    comm_out(0x40); //start line set
    comm_out(0xAF); //display ON

    delay(10);
}

/*****

```

Quality Information

Test Item	Content of Test	Test Condition	Note
High Temperature storage	Endurance test applying the high storage temperature for a long time.	+80°C , 96hrs	2
Low Temperature storage	Endurance test applying the low storage temperature for a long time.	-30°C , 96hrs	1,2
High Temperature Operation	Endurance test applying the electric stress (voltage & current) and the high thermal stress for a long time.	+70°C, 96hrs	2
Low Temperature Operation	Endurance test applying the electric stress (voltage & current) and the low thermal stress for a long time.	-20°C , 96hrs	1,2
High Temperature / Humidity Operation	Endurance test applying the electric stress (voltage & current) and the high thermal with high humidity stress for a long time.	+40°C , 90% RH , 96hrs	1,2
Thermal Shock resistance	Endurance test applying the electric stress (voltage & current) during a cycle of low and high thermal stress.	-0°C,30min -> 25°C,5min -> 50°C,30min = 1 cycle 10 cycles	
Vibration test	Endurance test applying vibration to simulate transportation and use.	10-55Hz , 15mm amplitude. 60 sec in each of 3 directions X,Y,Z For 15 minutes	3
Static electricity test	Endurance test applying electric static discharge.	VS=800V, RS=1.5kΩ, CS=100pF One time	

Note 1: No condensation to be observed.

Note 2: Conducted after 4 hours of storage at 25°C, 0%RH.

Note 3: Test performed on product itself, not inside a container.

Precautions for using LCDs/LCMs

See Precautions at www.newhavendisplay.com/specs/precautions.pdf

Warranty Information

See Terms & Conditions at http://www.newhavendisplay.com/index.php?main_page=terms

Компания «Life Electronics» занимается поставками электронных компонентов импортного и отечественного производства от производителей и со складов крупных дистрибьюторов Европы, Америки и Азии.

С конца 2013 года компания активно расширяет линейку поставок компонентов по направлению коаксиальный кабель, кварцевые генераторы и конденсаторы (керамические, пленочные, электролитические), за счёт заключения дистрибьюторских договоров

Мы предлагаем:

- Конкурентоспособные цены и скидки постоянным клиентам.
- Специальные условия для постоянных клиентов.
- Подбор аналогов.
- Поставку компонентов в любых объемах, удовлетворяющих вашим потребностям.
- Приемлемые сроки поставки, возможна ускоренная поставка.
- Доставку товара в любую точку России и стран СНГ.
- Комплексную поставку.
- Работу по проектам и поставку образцов.
- Формирование склада под заказчика.
- Сертификаты соответствия на поставляемую продукцию (по желанию клиента).
- Тестирование поставляемой продукции.
- Поставку компонентов, требующих военную и космическую приемку.
- Входной контроль качества.
- Наличие сертификата ISO.

В составе нашей компании организован Конструкторский отдел, призванный помогать разработчикам, и инженерам.

Конструкторский отдел помогает осуществить:

- Регистрацию проекта у производителя компонентов.
- Техническую поддержку проекта.
- Защиту от снятия компонента с производства.
- Оценку стоимости проекта по компонентам.
- Изготовление тестовой платы монтаж и пусконаладочные работы.



Тел: +7 (812) 336 43 04 (многоканальный)

Email: org@lifeelectronics.ru