

400M Series - 0603 Low Resistance Fast Acting Fuse



Description

The 400M Series is an 0603 Fast Acting fuse which offers relatively low resistance best suited for application which requires such. The part is 100% Lead-free, RoHS compliant, and Halogen-free fuses designed to provide over-current protection to circuits that operate under high operating temperatures of up to 150°C.

Features

- Operating temperature from -55°C to 150°C
- Suitable for both leaded and lead-free soldering
- 100% Lead-free, RoHS compliant, and Halogenfree

Applications

- Burn-in Test

Electrical Characteristics

% of Ampere Rating	Opening Time at 25°C
100%	4 Hours Minimum
200%	5 Seconds Maximum

Additional Information



Datashheet



Resources



Samples

Electrical Specifications by Item

Ampere Rating (A)	Amp Code	Max. Voltage Rating (V)	Interrupting Rating	Nominal Resistance (Ohms)	Nominal Melting I ² t (A ² Sec.)	Nominal Voltage Drop at Rated Current (mV)	Nominal Power Dissipation at Rated Current (W)
0.5	0025	5	50A @ 5VDC	0.325	0.00169	189	0.095
1.5	0026	5		0.095	0.03	161	0.242

Notes:

1. Cold resistance measured at less than 10% of rated current at 23°C.

2. I²t values stated for 1msec opening time.

Temperature Re-rating Curve

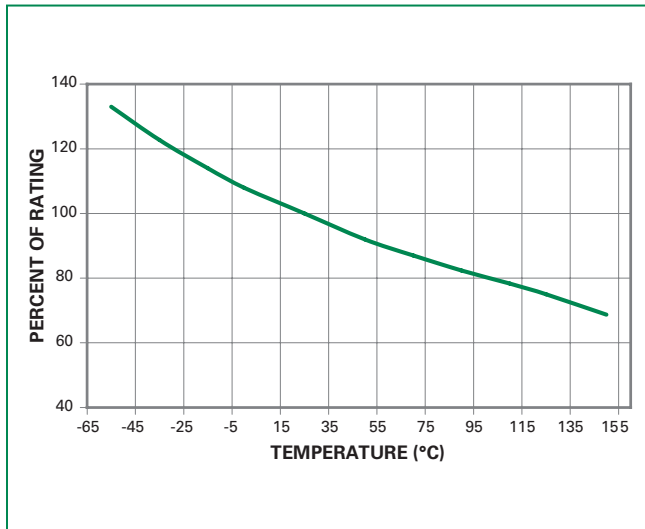

Note:

Re-rating depicted in this curve is in addition to the standard re-rating of 20% for continuous operation.

Average Time Current Curves

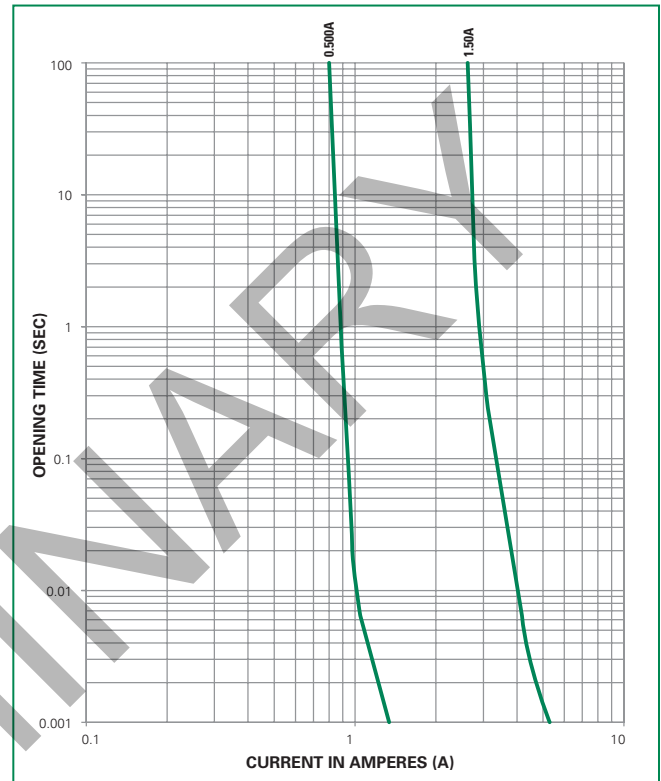

Soldering Parameters

Reflow Condition		Pb – free assembly
Pre Heat	- Temperature Min ($T_{s(min)}$)	150°C
	- Temperature Max ($T_{s(max)}$)	200°C
	- Time (Min to Max) (t_s)	60 – 180 seconds
Average Ramp-up Rate (Liquidus Temp (T_L) to peak)		5°C/second max.
$T_{s(max)}$ to T_L - Ramp-up Rate		5°C/second max.
Reflow	- Temperature (T_L) (Liquidus)	217°C
	- Temperature (t_L)	60 – 150 seconds
Peak Temperature (T_p)		260 ^{+0/-5} °C
Time within 5°C of actual peak Temperature (t_p)		20 – 40 seconds
Ramp-down Rate		5°C/second max.
Time 25°C to peak Temperature (T_p)		8 minutes max.
Do not exceed		260°C

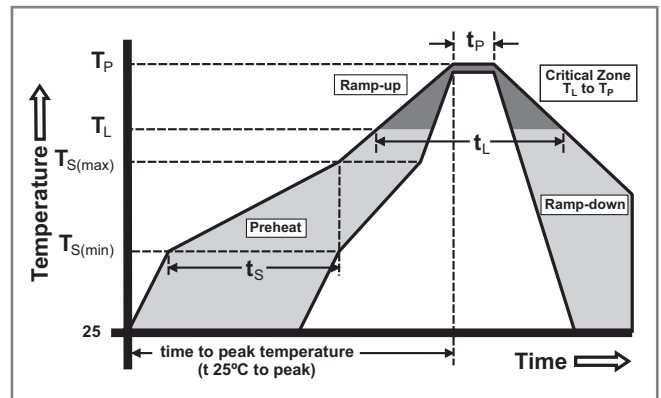

Product Characteristics

Materials	Body: Advanced Ceramic Terminations: Ag/Ni/Sn (100% Lead-free) Element Cover Coating: Lead-free Glass
Moisture Sensitivity Level	IPC/JEDEC J-STD-020C, Level 1
Solderability	IPC/ECA/JEDEC J-STD-002B, Condition B
Humidity Test	MIL-STD-202, Method 103B, Conditions D
Resistance to Solder Heat	MIL-STD-202, Method 210F, Condition B

Moisture Resistance	MIL-STD-202, Method 106G
Thermal Shock	MIL-STD-202, Method 107G Condition B-3
Mechanical Shock	MIL-STD-202, Method 213B, Condition A
Vibration	MIL-STD-202, Method 201A
Vibration, High Frequency	MIL-STD-202, Method 204D, Condition D
Dissolution of Metallization	IPC/ECA/JEDEC J-STD-002B, Condition D
Terminal Strength	IEC 60127-4

Dimensions

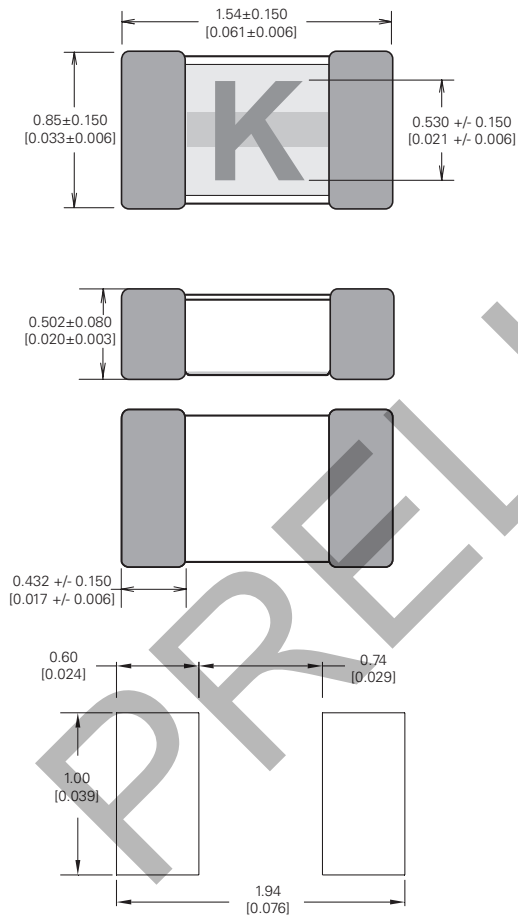

Part Marking System

Amp Code	Marking Code
0025	F
0026	K

Part Numbering System

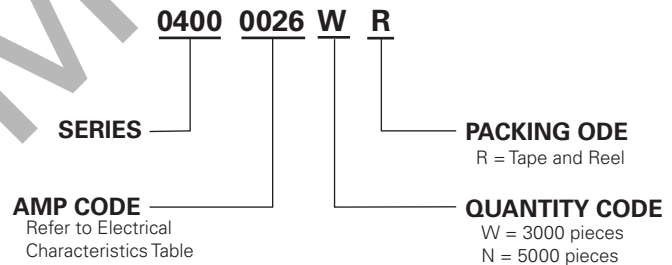

Disclaimer Notice - Information furnished is believed to be accurate and reliable. However, users should independently evaluate the suitability of and test each product selected for their own applications. Littelfuse products are not designed for, and may not be used in, all applications. Read complete Disclaimer Notice at www.littelfuse.com/disclaimer-electronics.

Packaging

Packaging Option	Form Factor	Packaging Specification	Quantity	Quantity & Packaging Code
8mm Tape and Reel	Surface Mount	EIA-481, IEC 60286, Part 3	3000	WR
8mm Tape and Reel	Surface Mount	EIA-481, IEC 60286, Part 3	5000	NR

Компания «Life Electronics» занимается поставками электронных компонентов импортного и отечественного производства от производителей и со складов крупных дистрибьюторов Европы, Америки и Азии.

С конца 2013 года компания активно расширяет линейку поставок компонентов по направлению коаксиальный кабель, кварцевые генераторы и конденсаторы (керамические, пленочные, электролитические), за счёт заключения дистрибьюторских договоров

Мы предлагаем:

- Конкурентоспособные цены и скидки постоянным клиентам.
- Специальные условия для постоянных клиентов.
- Подбор аналогов.
- Поставку компонентов в любых объемах, удовлетворяющих вашим потребностям.
- Приемлемые сроки поставки, возможна ускоренная поставка.
- Доставку товара в любую точку России и стран СНГ.
- Комплексную поставку.
- Работу по проектам и поставку образцов.
- Формирование склада под заказчика.
- Сертификаты соответствия на поставляемую продукцию (по желанию клиента).
- Тестирование поставляемой продукции.
- Поставку компонентов, требующих военную и космическую приемку.
- Входной контроль качества.
- Наличие сертификата ISO.

В составе нашей компании организован Конструкторский отдел, призванный помогать разработчикам, и инженерам.

Конструкторский отдел помогает осуществить:

- Регистрацию проекта у производителя компонентов.
- Техническую поддержку проекта.
- Защиту от снятия компонента с производства.
- Оценку стоимости проекта по компонентам.
- Изготовление тестовой платы монтаж и пусконаладочные работы.



Тел: +7 (812) 336 43 04 (многоканальный)

Email: org@lifeelectronics.ru