

FCI PART NUMBER	DESCRIPTION	NOTES
10122527-XXXXLF	CONTROLLER TO BACKPLANE CONFIGURATION	SEE TABLE 2

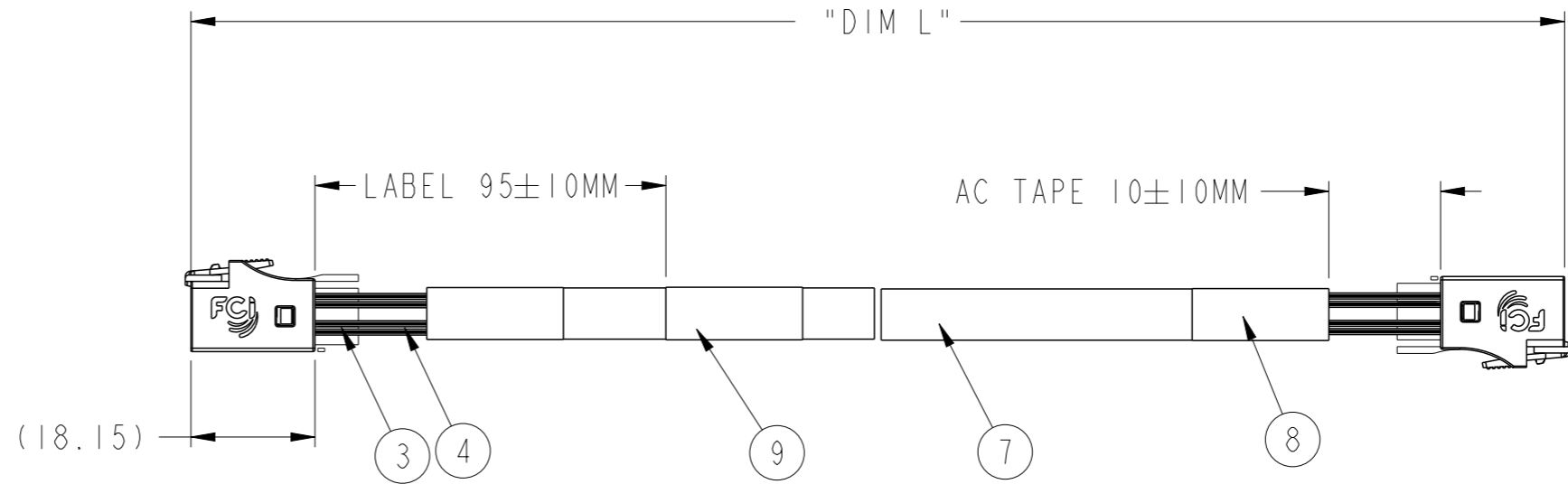
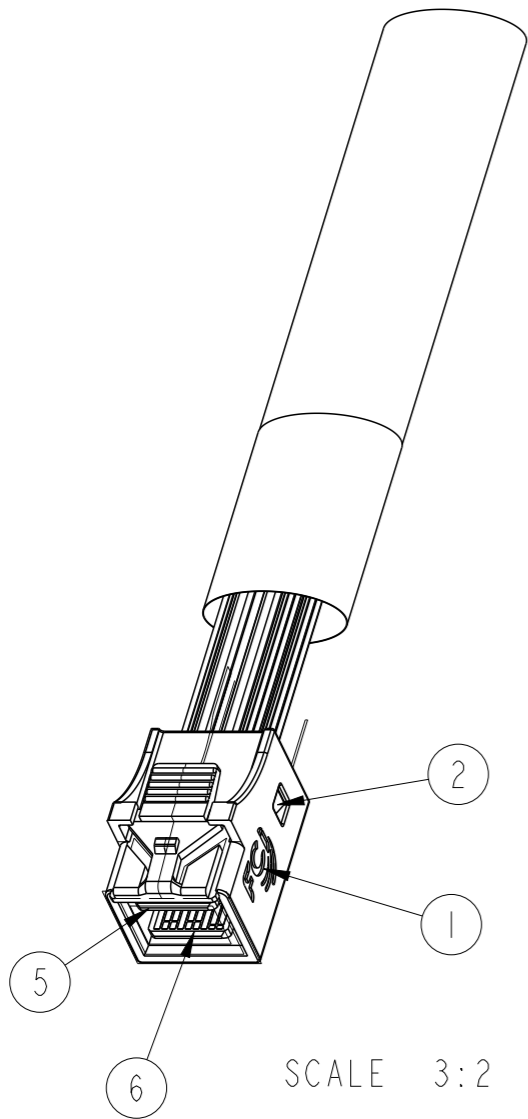

TABLE 1 - BILL OF MATERIALS

ITEM	DESCRIPTION	QTY	NOTES
1	mSAS HD INTERNAL HOUSING- SHORT	2	
2	mSAS HD INTERNAL PCB INSERT- SHORT	2	
3	3M FLAT RIBBON CABLE (30 AWG)	A/R	
4	SIDE BAND FLAT RIBBON CABLE (30 AWG)	A/R	
5	mSAS HD INTERNAL LOWER (A-B) PCB	2	
6	mSAS HD INTERNAL UPPER (C-D) PCB	2	
7	PLASTIC BRAID	A/R	
8	ACETATE TAPE 20mm BLACK	A/R	
9	LABEL	1	SEE NOTE 5
10	3525 LOCTITE	A/R	NOT SHOWN

spec ref	-	dr	Andy Wu	2013/01/03	projection	mm	size	A3	scale	1:1
tolerance std	ISO 406 ISO 1101	eng	Ya LI	2015/04/28			ecn no	ELX-N-20750-1		
	TOLERANCES UNLESS OTHERWISE SPECIFIED	chr	-	apppr			Delhy Liu	2015/04/28	product family	-
surface	ISO 1302	linear	0.X	±0.3		mSAS HD INTERNAL (4i) CABLE ASSEMBLY- 12 Gb/s, short type	dwg no 10122527	rev J		
			0.XX	±0.10						
			0.XXX	±0.005						
		angular	0°	±2°	www.fci.com	cat. no.	-	Product - Customer Drw	sheet 1 of 4	

FCI PART NUMBER	DESCRIPTION	NOTES
10122527-XXXXLF	CONTROLLER TO BACKPLANE CONFIGURATION	SEE TABLE 2

TABLE 2- CABLE PART NUMBER LIST			
PART NUMBER	"DIM L" CABLE LENGTH (METERS)	AWG	NOTES
10122527-2030LF	0.3	30	CONTROLLER TO BACKPLANE WIRING CONFIGURATION (SHEET 2) ----- (SEE SHEET 4 FOR ALL NOTES)
10122527-2040LF	0.4	30	
10122527-2050LF	0.5	30	
10122527-2060LF	0.6	30	
10122527-2070LF	0.7	30	
10122527-2075LF	0.75	30	
10122527-2080LF	0.8	30	
10122527-2090LF	0.9	30	
10122527-2100LF	1.0	30	
10122527-2035LF	0.35	30	
10122527-2043LF	0.436	30	
10122527-2095LF	0.95	30	



- NOTE:
- ALL CABLE PERFORMANCE COMPLIANCE SAS3.0
 - CABLE MORE THAN 1.0 METER COULD NOT MEET SAS3.0 INSERTION LOSS -11dB MAX.

spec ref	-	dr	Andy Wu	2013/01/03	projection	mm	size	A3	scale	1:2
tolerance std	ISO 406 ISO 1101	eng	Ya Li	2015/04/28			ecn no	ELX-N-20750-1		
	TOLERANCES UNLESS OTHERWISE SPECIFIED	chr	-	-			product family	-	rel level	Released
surface	ISO 1302	linear	0.X	±0.3		mSAS HD INTERNAL (4i) CABLE ASSEMBLY- 12 Gb/s, short type	dwg no 10122527	rev J		
			0.XX	±0.10						
			0.XXX	±0.005						
		angular	0°	±2°	www.fci.com	cat. no.	-	Product - Customer Drw	sheet 2 of 4	



FCI PART NUMBER	DESCRIPTION	NOTES
10122527-XXXXLF	CONTROLLER TO BACKPLANE CONFIGURATION	SEE TABLE 2

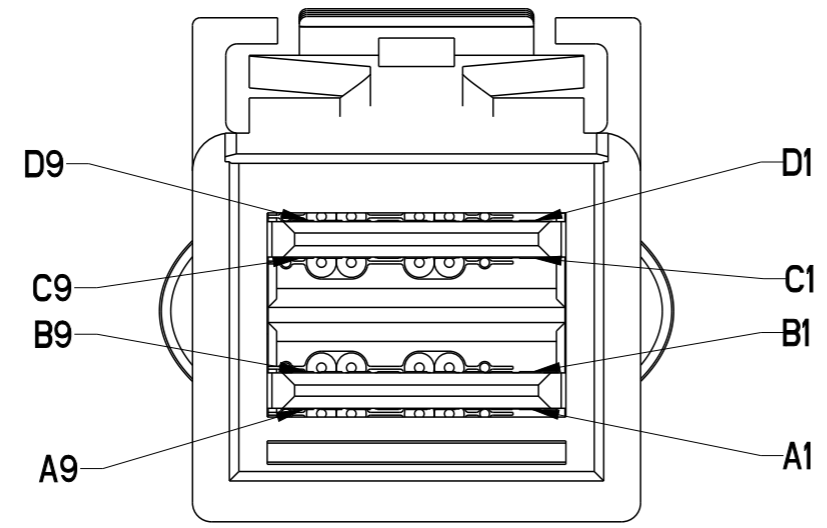

SCALE 5:1

LEGEND	
	HIGH-SPEED SERIAL DIFFERENTIAL PAIRS
	SIGNAL RETURN
	SIDEBAND SIGNAL

WIRING LIST (CONTROLLER TO BACKPLANE)				
END P1 (CONTROLLER)			END P2 (BACKPLANE)	
POSITION	SYMBOL		POSITION	SYMBOL
D9	GROUND	-----	B9	GROUND
D8	Tx2-		B8	Rx2-
D7	Tx2+		B7	Rx2+
D6	GROUND	-----	B6	GROUND
D5	Tx0-		B5	Rx0-
D4	Tx0+		B4	Rx0+
D3	GROUND	-----	B3	GROUND
D2	SIDEBAND 6		D1	SIDEBAND 6
D1	SIDEBAND 5		D2	SIDEBAND 5
C1	SIDEBAND 4		C2	SIDEBAND 4
C2	SIDEBAND 2		C1	SIDEBAND 2
C3	GROUND	-----	A3	GROUND
C4	Tx1+		A4	Rx1+
C5	Tx1-		A5	Rx1-
C6	GROUND	-----	A6	GROUND
C7	Tx3+		A7	Rx3+
C8	Tx3-		A8	Rx3-
C9	GROUND	-----	A9	GROUND
B9	GROUND	-----	D9	GROUND
B8	Rx2-		D8	Tx2-
B7	Rx2+		D7	Tx2+
B6	GROUND	-----	D6	GROUND
B5	Rx0-		D5	Tx0-
B4	Rx0+		D4	Tx0+
B3	GROUND	-----	D3	GROUND
B2	SIDEBAND 1		B1	SIDEBAND 1
B1	SIDEBAND 3		B2	SIDEBAND 3
A1	SIDEBAND 7		A2	SIDEBAND 7
A2	SIDEBAND 0		A1	SIDEBAND 0
A3	GROUND	-----	C3	GROUND
A4	Rx1+		C4	Tx1+
A5	Rx1-		C5	Tx1-
A6	GROUND	-----	C6	GROUND
A7	Rx3+		C7	Tx3+
A8	Rx3-		C8	Tx3-
A9	GROUND	-----	C9	GROUND

spec ref	-	dr	Andy Wu	2013/01/03	projection	mm	size	A3	scale	1:1				
tolerance std	ISO 406 ISO 1101	eng	Ya Li	2015/04/28		← →	ecn no	ELX-N-20750-1						
TOLERANCES UNLESS OTHERWISE SPECIFIED		chr	-	app				Delhly Liu	2015/04/28	rel level	Released			
surface	ISO 1302	linear	0.X	±0.3		mSAS HD INTERNAL (4i) CABLE ASSEMBLY- 12 Gb/s, short type	dwg no	10122527		rev	J			
			0.XX	±0.10				www.fci.com	cat. no.			-	Product - Customer Drw	sheet 3 of 4
		angular	0°	±2°										

Copyright FCI.

NOTES:

1. MATERIAL:
 HOUSINGS: MODIFIED POLYPHENYLENE ETHER
 PADDLE CARD: PRINTED CIRCUIT SUBSTRATE
 HEAT SHRINK TUBE: POLYOLEFIN
 EPOXY LOCTITE

2. THIS PRODUCT MEETS THE RESTRICTION OF HAZARDOUS SUBSTANCES IN ELECTRICAL AND ELECTRONIC EQUIPMENT (RoHS) DIRECTIVE (2002/95/EC)

3. THIS DIMENSION IS A FINISHED PRODUCT LENGTH.

4. UNLESS OTHERWISE SPECIFIED ASSEMBLED LENGTH TOLERANCE IS TO BE:
 "DIM L" < 1 METER = 25mm
 "DIM L" 1 METER TO 10 METERS = 2% OF "DIM L"

5. UNLESS OTHERWISE SPECIFIED LABEL POSITION IS TO BE 95mm FROM REAR OF PI CONNECTOR.
 LABEL DETAILS:
 MANUFACTURER CODE OR NAME COUNTRY OF ORIGIN
 CUSTOMER P/N OR FCI P/N
 REVISION
 DATE CODE (YYYY/MM/DD FORMAT) - SERIAL NUMBER

FONT SHALL BE CLEARLY VISIBLE AND BLACK IN COLOR.

6. ALL CABLE ASSEMBLIES SHALL BE 100% TESTED FOR CONTINUITY AS DEFINED IN WIRING LIST.

7. ALL CABLE ASSEMBLIES SHALL BE 100% HI-POT TESTED BH APPLYING 300V DC FOR A MINIMUM OF 10ms.

8. IMPEDANCE: 100 DIFFERENTIAL.

9. OTHER TESTING PERFORMED AS REQUIRED BY PRODUCT SPECIFICATION: GS-12-650.

10. PACKAGE AND LABEL CABLE ASSEMBLIES PER GS-14-1272.



11. A "  " SYMBOL WILL BE NEXT TO ANY DIMENSION, VIEW, OR NOTE WHICH HAS BEEN MODIFIED WITH THE CURRENT DRAWING REVISION. THE CURRENT REVISION WILL BE SHOWN IN THE SYMBOL.

12. "HLF" PRODUCT NUMBERS DESIGNATE THE USE OF HALOGEN FREE RAW CABLE.

13. HALOGEN FREE RAW CABLE CAN BE USED AS A SUBSTITUTE ON NON-HF PRODUCT NUMBERS.

14. PART NUMBER/SUPPLIER SUBSTITUTION IS NOT ALLOWED.

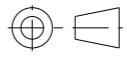
15. THIS PRODUCT CONFORMS TO THE MECHANICAL DIMENSIONING AND ELECTRICAL REQUIREMENTS OF THE SFF-8643 SPECIFICATION.

spec ref		-		dr	Andy Wu	2013/01/03	projection	mm	size	A3	scale	1:1
tolerance std		TOLERANCES UNLESS OTHERWISE SPECIFIED		eng	Ya Li	2015/04/28				ecn no	ELX-N-20750-1	
ISO 406				chr	-	-	product family	-			rel level	
ISO 1101				appr	Delhy Liu	2015/04/28			Released			
surface		linear	0.X	±0.3		mSAS HD INTERNAL (4i) CABLE ASSEMBLY- 12 Gb/s, short type	cat. no.	-	Product - Customer Drw	sheet 4 of 4	rev J	dwg no 10122527
			0.XX	±0.10								
			0.XXX	±0.005								
ISO 1302		angular	0°	±2°	www.fci.com							



Copyright FCI.

Компания «Life Electronics» занимается поставками электронных компонентов импортного и отечественного производства от производителей и со складов крупных дистрибьюторов Европы, Америки и Азии.

С конца 2013 года компания активно расширяет линейку поставок компонентов по направлению коаксиальный кабель, кварцевые генераторы и конденсаторы (керамические, пленочные, электролитические), за счёт заключения дистрибьюторских договоров

Мы предлагаем:

- Конкурентоспособные цены и скидки постоянным клиентам.
- Специальные условия для постоянных клиентов.
- Подбор аналогов.
- Поставку компонентов в любых объемах, удовлетворяющих вашим потребностям.
- Приемлемые сроки поставки, возможна ускоренная поставка.
- Доставку товара в любую точку России и стран СНГ.
- Комплексную поставку.
- Работу по проектам и поставку образцов.
- Формирование склада под заказчика.
- Сертификаты соответствия на поставляемую продукцию (по желанию клиента).
- Тестирование поставляемой продукции.
- Поставку компонентов, требующих военную и космическую приемку.
- Входной контроль качества.
- Наличие сертификата ISO.

В составе нашей компании организован Конструкторский отдел, призванный помогать разработчикам, и инженерам.

Конструкторский отдел помогает осуществить:

- Регистрацию проекта у производителя компонентов.
- Техническую поддержку проекта.
- Защиту от снятия компонента с производства.
- Оценку стоимости проекта по компонентам.
- Изготовление тестовой платы монтаж и пусконаладочные работы.



Тел: +7 (812) 336 43 04 (многоканальный)

Email: org@lifeelectronics.ru