



Photocouplers

LTV-0601 (Preliminary Version)

Data Sheet

Created Date : 01/ 02/ 2012

Revision : 1.0, 01/ 02/ 2012



Lite-on Technology Corp.

Optoelectronics SBG

<http://www.liteon.com/opto>



Photocouplers LTV-0601(Preliminary version)

I. DESCRIPTION

The LTV-0601 consists of a high efficient AlGaAs Light Emitting Diode and a high speed optical detector. This design provides excellent AC and DC isolation between the input and output sides of the Optocoupler. The output of the optical detector features an open collector Schottky clamped transistor. The enable function allows the optical detector to be strobed. A guaranteed common mode transient immunity is up to 15,000V/μs.

The Optocoupler operational parameters are guaranteed over the temperature range from -40°C ~ +85°C.

1.1 Features

- SO8 package
- High speed – 10MBd typical
- Guaranteed AC and DC performance over temperature -40°C ~ +85°C.
- LSTTL/TTL Compatible.
- Storable output.

1.2 Applications

- Isolation in line receivers
- Ground loop elimination
- Feedback Element in Switching Mode Power Supplier
- High Speed Logic Ground Isolation – TTL/TTL, TTL/CMOS, TTL/LSTTL
- Pulse transformer replacement
- Power transistor isolation in motor drives
- Interface between Microprocessor system, computer and their peripheral

1.3 Functional Diagram

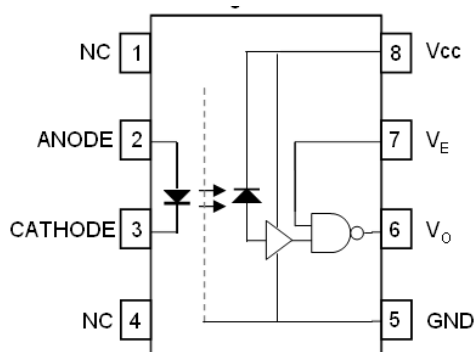

Truth Table (Positive Logic)

LED	ENABLE	OUT
ON	H	L
OFF	H	H
ON	L	H
OFF	L	H
ON	NC	L
OFF	NC	H

A 0.1μF bypass Capacitor must be connected between Pin8 and Pin5

Photocouplers
LTV-0601(Preliminary version)

2. PACKAGE DIMENSIONS

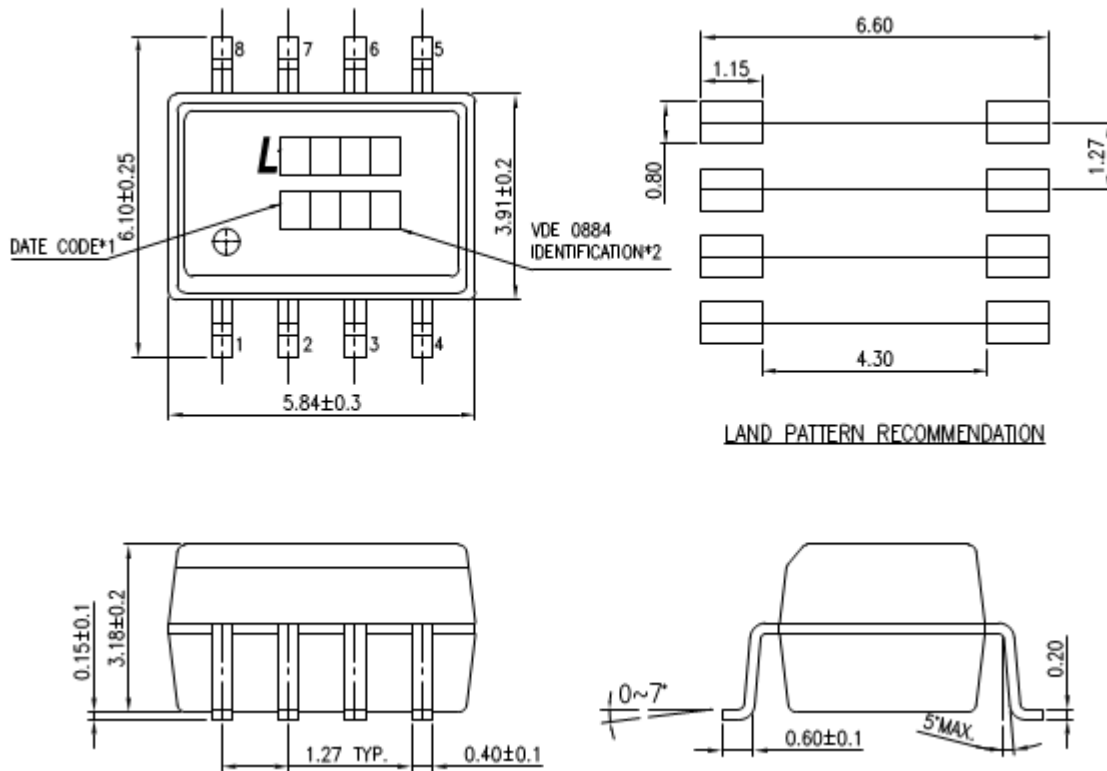

Part No : LTV-0601

Notes :

1. Date code
2. "V" to represent VDE0884
3. Date code
4. Dimensions are all in Millimeters.

Photocouplers
LTV-0601(Preliminary version)

3. TAPING DIMENSIONS

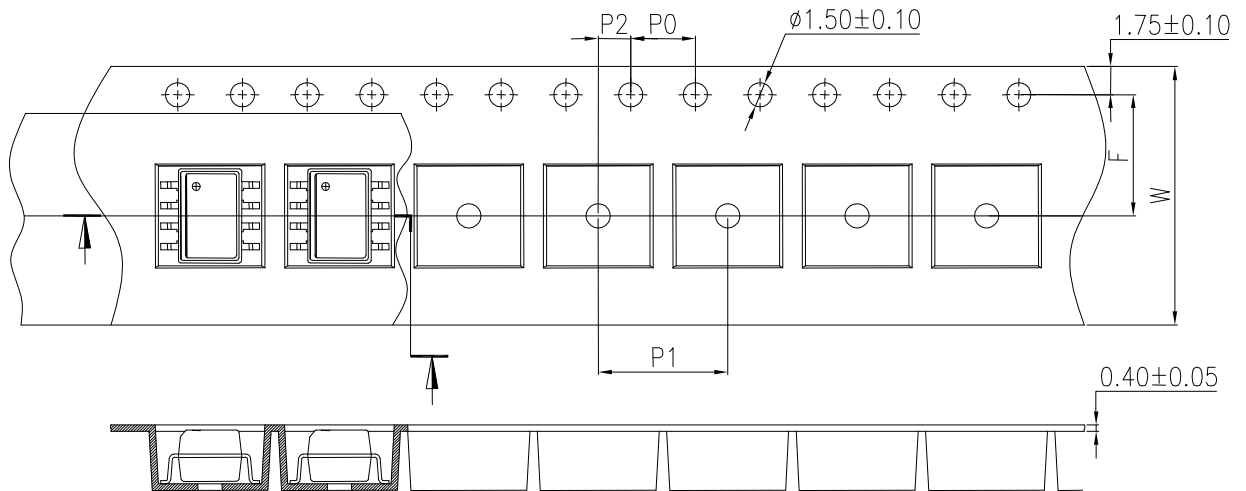

Description	Symbol	Dimension in mm (inch)
Tape wide	W	16±0.3 (0.63)
Pitch of sprocket holes	P_0	4±0.1 (0.15)
Distance of compartment	F	7.5±0.1 (0.295)
	P_2	2±0.1 (0.079)
Distance of compartment to compartment	P_1	8±0.1 (0.47)

Quantities Per Reel

Package Type	LTV-0601
Quantities (pcs)	2000

Photocouplers LTV-0601(Preliminary version)

4. RATING AND CHARACTERISTICS

4.1 Absolute Maximum Ratings at Ta=25°C *1

	Parameter	Symbol	Rating	Unit
Input	Average Forward Input Current	I_F	20	mA
	Reverse Input Voltage	V_R	5	V
	Power Dissipation	P_I	35	mW
	Enable Input Voltage	V_E	V _{CC} +5	V
	Enable Input current	I_E	5	mA
Output	Output Collector Current	I_O	50	mA
	Output Collector Voltage	V_O	7	V
	Output Collector Power Dissipation	P_O	85	mW
	Isolation Voltage	V_{iso}	3750	V _{rms}
	Supply Voltage	V_{CC}	7	V
	Operating Temperature	T_{opr}	-55 ~ +85	°C
	Storage Temperature	T_{stg}	-55 ~ +125	°C
	Lead Solder Temperature *2	T_{sol}	260	°C

1. Ambient temperature = 25°C, unless otherwise specified. Stresses exceeding the absolute maximum ratings can cause permanent damage to the device. Exposure to absolute maximum ratings for long periods of time can adversely affect reliability.
2. 260°C for 10 seconds. Refer to Lead Free Reflow Profile.

Photocouplers
LTV-0601(Preliminary version)

4.2 Recommended Operating Conditions

Parameter	Symbol	Min	Max	Unit
Operating Temperature	T_A	-40	85	°C
Supply Voltage	V_{CC}	4.5	5.5	V
Low Level Input Current	I_{FL}	0	250	μA
High Level Input Current	I_{FH}	5	15	mA
Low Level Enable Voltage	V_{EL}	0	0.8	V
High Level Enable Voltage	V_{EH}	2	V_{CC}	V
Output Pull-up Resistor	R_L	330	4k	Ω
Fan Out (at $R_L=1k\Omega$ per channel)	N	—	5	TTL Loads

Photocouplers LTV-0601(Preliminary version)

4.3 ELECTRICAL OPTICAL CHARACTERISTICS at Ta=25°C

Parameter	Symbol	Min.	Typ.	Max.	Unit	Test Condition
Input						
Input Forward Voltage	V_F	—	1.38	1.8	V	$I_F = 10\text{mA}$
Input Forward Voltage Temperature Coefficient	$\Delta V_F / \Delta T$	—	-1.6	—	mV/°C	$I_F = 10\text{mA}$
Input Reverse Voltage	BV_R	5.0	—	—	V	$I_R = 10\mu\text{A}$
Input Threshold Current	I_{TH}	—	1.35	5	mA	$V_E = 2\text{V}, V_{CC} = 5.5\text{V},$
		—	2 ⁽¹⁾	3	mA	$I_{OL}(\text{sinking}) = 13\text{mA}$
Input Capacitance	C_{IN}	—	34	—	pF	$f = 1\text{MHz}, V_F = 0\text{V}$
Detector						
High Level Supply Current	I_{CCH}	—	7.4	10	uA	$V_E = 0.5\text{V}, V_{CC} = 5.5\text{V},$ $I_F = 0\text{mA}$
Low Level Supply Current	I_{CCL}	—	10	13	mA	$V_E = 0.5\text{V}, V_{CC} = 5.5\text{V},$ $I_F = 10\text{mA}$
High Level Enable Current	I_{EH}	—	-0.6	-1.6	mA	$V_E = 2\text{V}$
Low Level Enable Current	I_{EL}	—	-0.9	-1.6	mA	$V_E = 0.5\text{V}$
High Level Enable Voltage	V_{EH}	2	—	—	V	
Low Level Enable Voltage	V_{EL}		—	0.8	V	
High Level Output Current	I_{OH}	—	—	100	μA	$V_E = 2\text{V}, V_{CC} = 5.5\text{V},$ $V_O = 5.5\text{V}, I_F = 250\mu\text{A}$
Low Level Output Voltage	V_{OL}	—	0.25	0.60	V	$V_E = 2\text{V}, V_{CC} = 5.5\text{V},$ $I_F = 5\text{mA},$ $I_{OL}(\text{sinking}) = 13\text{mA}$

Specified over recommended temperature ($T_A = -40^\circ\text{C}$ to $+85^\circ\text{C}$) unless otherwise specified. Typical values applies to $V_{CC} = 5\text{V}$, $T_A = 25^\circ\text{C}$. See note 1.

Photocouplers LTV-0601(Preliminary version)

5. SWITCHING SPECIFICATION

$T_A=0\sim 70^{\circ}\text{C}$, $V_{CC}=5\text{V}$, unless otherwise specified.

Parameter	Symbol	Min.	Typ.	Max.	Unit	Test Condition	Note
Propagation Delay Time to Low Output Level	t_{PHL}	25	40	100	ns	$R_L = 350\Omega$, $C_L = 15\text{pF}$	3
Propagation Delay Time to High Output Level	t_{PLH}	25	27	100	ns	$R_L = 350\Omega$, $C_L = 15\text{pF}$	4
Pulse Width Distortion	$ \mathbf{t_{PLH} - t_{PHL}} $	—	12	—	ns	$R_L = 350\Omega$, $C_L = 15\text{pF}$	—
Propagation Delay Skew	t_{PSK}	—	—	—	—	$R_L = 350\Omega$, $C_L = 15\text{pF}$	—
Output Rise Time (10 to 90%)	t_r	—	20	—	ns	$R_L = 350\Omega$, $C_L = 15\text{pF}$	—
Output Fall Time (90 to 10%)	t_f	—	6.6	—	ns	$R_L = 350\Omega$, $C_L = 15\text{pF}$	—
Propagation Delay Time of Enable from V_{EH} to V_{EL}	t_{ELH}	—	28	—	ns	$R_L = 350\Omega$, $C_L = 15\text{pF}$, $V_{EL} = 0\text{V}$, $V_{EH} = 3\text{V}$	5
Propagation Delay Time of Enable from V_{EL} to V_{EH}	t_{EHL}	—	12	—	V/ μs	$R_L = 350\Omega$, $C_L = 15\text{pF}$, $V_{EL} = 0\text{V}$, $V_{EH} = 3\text{V}$	6
Logic High Common Mode Transient Immunity	$ CM_H $	1,000	—	—	V/ μs	$ V_{CM} = 20\text{V}$, $V_{CC} = 5\text{V}$, $I_F = 0\text{mA}$, $V_{O(MIN)} = 2\text{V}$, $R_L = 350\Omega$, $T_A = 25^{\circ}\text{C}$	7,9
Logic Low Common Mode Transient Immunity	$ CM_L $	1,000	—	—	ns	$ V_{CM} = 20\text{V}$, $V_{CC} = 5\text{V}$, $I_F = 7.5\text{mA}$, $V_{O(MIN)} = 0\text{V}$, $R_L = 350\Omega$, $T_A = 25^{\circ}\text{C}$	8,9

*All Typical at $T_A=25^{\circ}\text{C}$

Photocouplers LTV-0601(Preliminary version)

6. ISOLATION CHARACTERISTIC

Parameter	Symbol	Min.	Typ.	Max.	Unit	Test Condition	Note
Input-Output Insulation Leakage Current	I_{I-O}	—	—	1.0	μA	45% RH, $t = 5s$, $V_{I-O} = 3kV$ DC, $T_A = 25^\circ C$	10,11
Withstand Insulation Test Voltage	V_{ISO}	3750	—	—	V_{RMS}	RH $\leq 50\%$, $t = 1min$, $T_A = 25^\circ C$	10,11,12
Input-Output Resistance	R_{I-O}	—	10^{12}	—	Ω	$V_{I-O} = 500V$ DC	10
Input-Output Capacitance	C_{I-O}	—	1.0	—	p	$f = 1MHz$, $T_A = 25^\circ C$	10

Specified over recommended temperature ($T_A = -40^\circ C$ to $+85^\circ C$) unless otherwise specified. Typical values applies to $T_A = 25^\circ C$

Notes

1. A 0.1 μF or bigger bypass capacitor for V_{CC} is needed as shown in Fig.1
2. Peaking driving circuit may be used to speed up the LED. The peak drive current of LED may go up to 50mA and maximum pulse width 50ns, as long as average current doesn't exceed 20mA.
3. t_{PLH} (propagation delay) is measured from the 3.75 mA point on the falling edge of the input pulse to the 1.5 V point on the rising edge of the output pulse.
4. t_{PHL} (propagation delay) is measured from the 3.75 mA point on the rising edge of the input pulse to the 1.5 V point on the falling edge of the output pulse.
5. The t_{ELH} enable propagation delay is measured from the 1.5 V point on the falling edge of the enable input pulse to the 1.5 V point on the rising edge of the output pulse.
6. The t_{EHL} enable propagation delay is measured from the 1.5 V point on the rising edge of the enable input pulse to the 1.5 V point on the falling edge of the output pulse.
7. CM_H is the maximum tolerable rate of rise of the common mode voltage to assure that the output will remain in a high logic state (i.e., $V_O > 2.0 V$).
8. CM_L is the maximum tolerable rate of fall of the common mode voltage to assure that the output will remain in a low logic state (i.e., $V_O < 0.8 V$).
9. No external pull up is required for a high logic state on the enable input. If the enable pin is not used, tying it to V_{CC} .
10. Device is considered a two-terminal device: pins 1, 2, 3, and 4 shorted together, and pins 5, 6, 7, and 8 shorted together.
11. In accordance with UL1577, each optocoupler is proof tested by applying an insulation test voltage 3000 V rms for one second (leakage current less than 5 uA). This test is performed before the 100% production test for partial discharge

Photocouplers LTV-0601(Preliminary version)

7. SWITCHING TIME TEST CIRCUIT

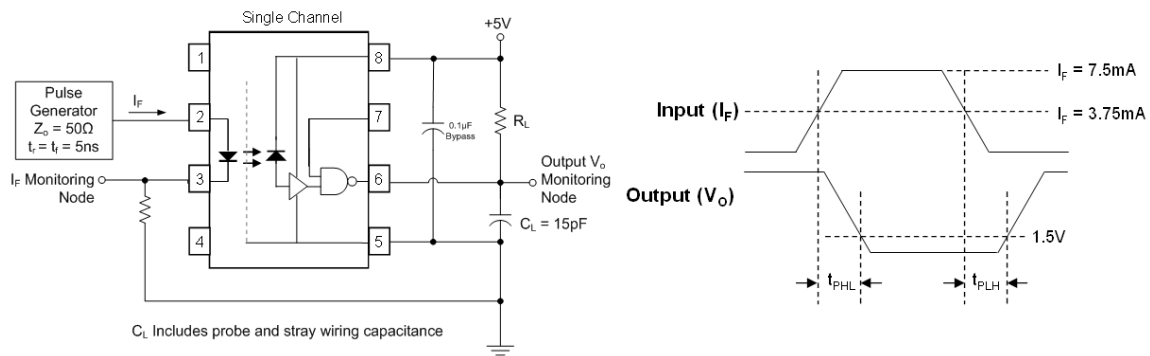

Figure 1: Single Channel Test Circuit for t_{PHL} and t_{PLH}

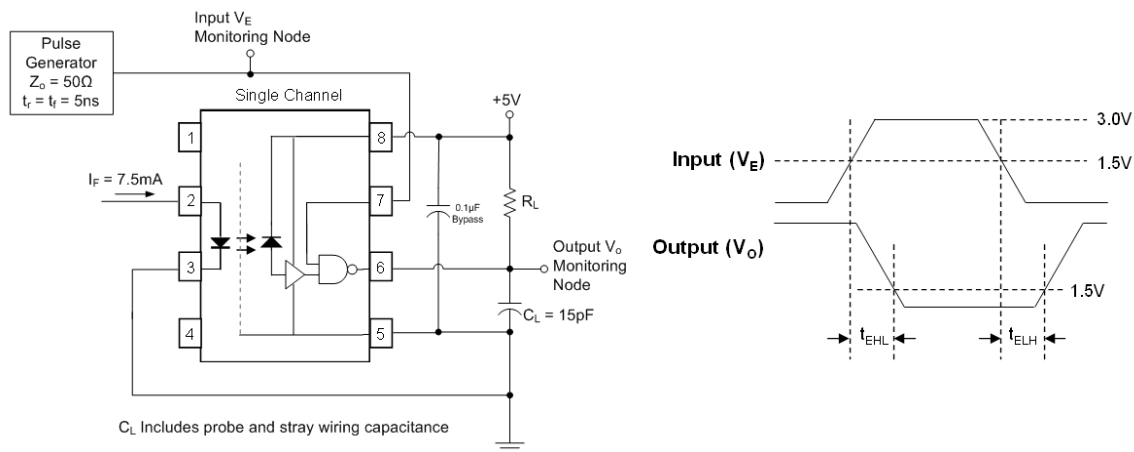

Figure 2: Single Channel Test Circuit for Common Mode Transient Immunity

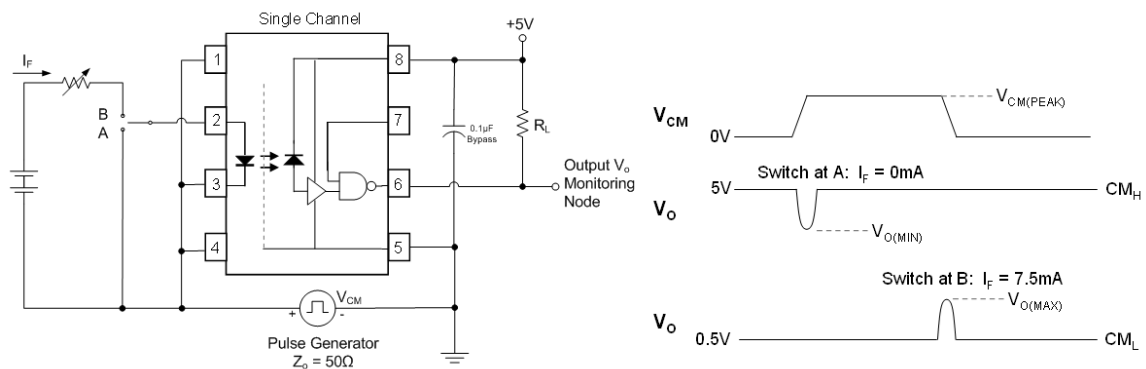

Figure 3: Single Channel Test Circuit for Common Mode Transient Immunity

Photocouplers
LTV-0601(Preliminary version)

8. TEMPERATURE PROFILE OF SOLDERING

8.1 IR Reflow soldering (JEDEC-STD-020C compliant)

One time soldering reflow is recommended within the condition of temperature and time profile shown below. Do not solder more than three times.

Profile item	Conditions
Preheat	
- Temperature Min (T_{Smin})	150°C
- Temperature Max (T_{Smax})	200°C
- Time (min to max) (ts)	90±30 sec
Soldering zone	
- Temperature (T_L)	217°C
- Time (t_L)	60 sec
Peak Temperature (T_P)	260°C
Ramp-up rate	3°C / sec max.
Ramp-down rate	3~6°C / sec

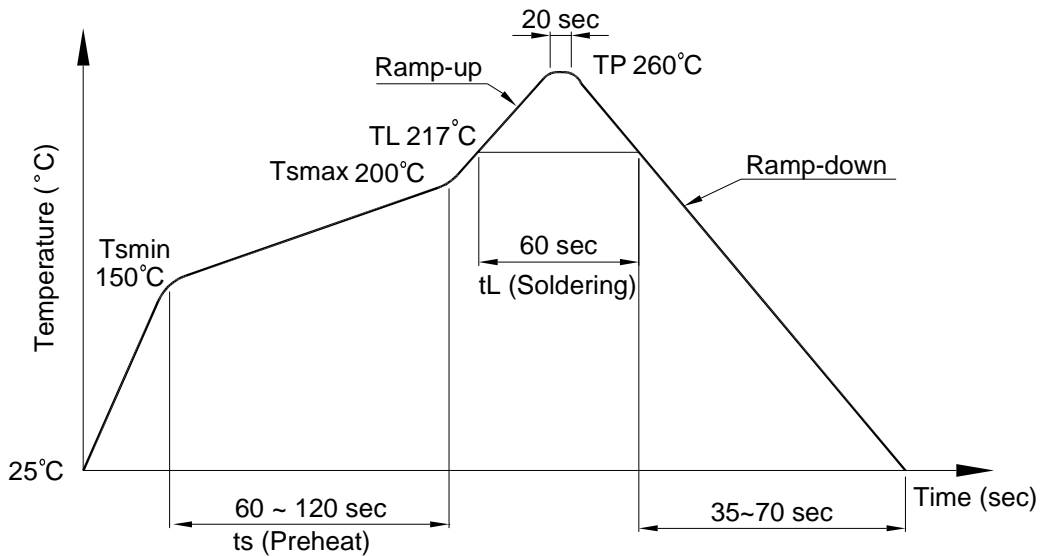

Photocouplers LTV-0601(Preliminary version)

8.2 Wave soldering (JEDEC22A111 compliant)

One time soldering is recommended within the condition of temperature.

Temperature: $260+0/-5^{\circ}\text{C}$

Time: 10 sec.

Preheat temperature: 25 to 140°C

Preheat time: 30 to 80 sec.

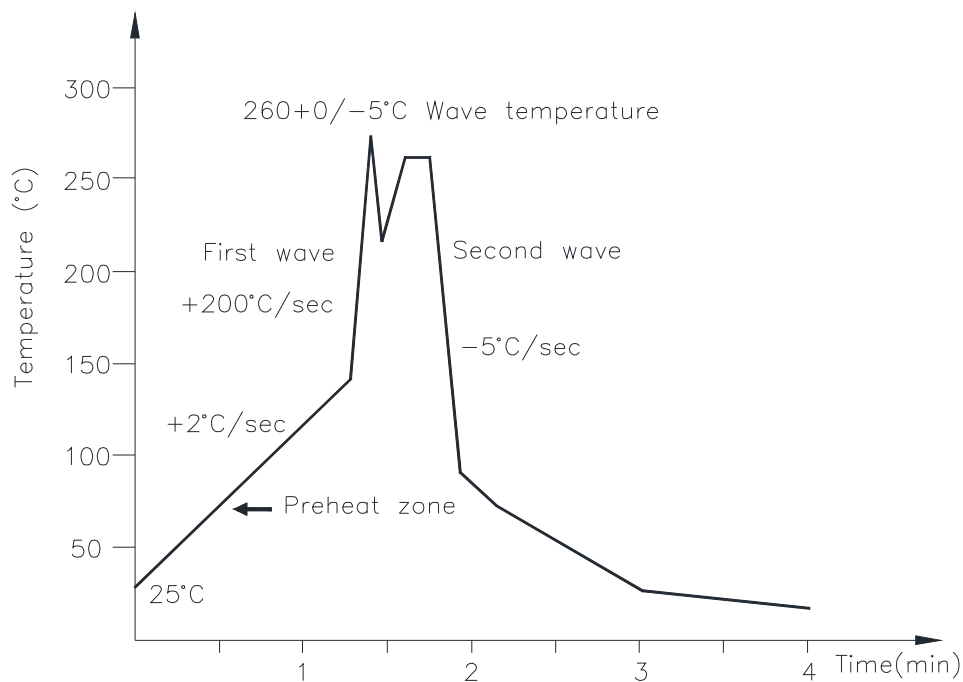

8.3 Hand soldering by soldering iron

Allow single lead soldering in every single process. One time soldering is recommended.

Temperature: $380+0/-5^{\circ}\text{C}$

Time: 3 sec max.

9. Notes:

Specifications of the products displayed herein are subject to change without notice.

The products shown in this publication are designed for the general use in electronic applications such as office automation equipment, communications devices, audio/visual equipment, electrical instrumentation and application. For equipment/devices where high reliability or safety is required, such as space applications, nuclear power control equipment, medical equipment, etc, please contact our sales representatives.

Компания «Life Electronics» занимается поставками электронных компонентов импортного и отечественного производства от производителей и со складов крупных дистрибьюторов Европы, Америки и Азии.

С конца 2013 года компания активно расширяет линейку поставок компонентов по направлению коаксиальный кабель, кварцевые генераторы и конденсаторы (керамические, пленочные, электролитические), за счёт заключения дистрибьюторских договоров

Мы предлагаем:

- Конкуренспособные цены и скидки постоянным клиентам.
- Специальные условия для постоянных клиентов.
- Подбор аналогов.
- Поставку компонентов в любых объемах, удовлетворяющих вашим потребностям.
- Приемлемые сроки поставки, возможна ускоренная поставка.
- Доставку товара в любую точку России и стран СНГ.
- Комплексную поставку.
- Работу по проектам и поставку образцов.
- Формирование склада под заказчика.
- Сертификаты соответствия на поставляемую продукцию (по желанию клиента).
- Тестирование поставляемой продукции.
- Поставку компонентов, требующих военную и космическую приемку.
- Входной контроль качества.
- Наличие сертификата ISO.

В составе нашей компании организован Конструкторский отдел, призванный помогать разработчикам, и инженерам.

Конструкторский отдел помогает осуществить:

- Регистрацию проекта у производителя компонентов.
- Техническую поддержку проекта.
- Защиту от снятия компонента с производства.
- Оценку стоимости проекта по компонентам.
- Изготовление тестовой платы монтаж и пусконаладочные работы.



Тел: +7 (812) 336 43 04 (многоканальный)

Email: org@lifeelectronics.ru