



# ATS Brochure Kit

## PRODUCT OVERVIEW



**ATS** **ADVANCED  
THERMAL  
SOLUTIONS, INC.**  
Innovations in Thermal Management®

Advanced Thermal Solutions, Inc.  
89-27 Access Road | Norwood, MA 02062 | USA  
[www.qats.com](http://www.qats.com) | T: 781.769.2800 | F: 781.769.9979



# ATS Brochure Kit

## PRODUCT OVERVIEW

Heat Sink Overview .....	4
Heat Sink Comparison .....	5
BGA Cooling Solutions .....	6
blueICE™ .....	7
blackDIAMOND™ .....	8
powerICE™ .....	9
Pin Fin Extrusion .....	10
Straight Fin Extrusion .....	11
Cross Cut Heat Sinks .....	12
maxiFLOW™ Extrusion .....	13
maxiFLOW™ with Thermal Tape .....	14
maxiGRIP™ Heat Sink Clip Attachment .....	15-16
Straight Fin with maxiGRIP™ .....	17
maxiGRIP™ Clearance Guidelines .....	18
maxiFLOW™ with superGRIP™ .....	19
Straight Fin with superGRIP™ .....	20
superGRIP™ Clearance Guidelines .....	21
Straight Fin with Thermal Tape .....	22
STAR™ LED Heat Sink .....	23
Extrusion Profiles .....	24
maxiFLOW™ Cross Cut with Plastic Push Pin .....	25
maxiFLOW™ Cross Cut with Metal Push Pin.....	26
maxiFLOW™ Cross Cut with Hardware Attachment .....	27
fanSINK™ .....	28
Thermal Consulting Services .....	29
iQ-200™ .....	30
ATVS-NxT™ .....	31



# ATS Brochure Kit INSTRUMENTS

ATVS-2020™ .....	32
eATVS-4™ and eATVS-8™ .....	33
ATVS-2000™ .....	34
Sensors .....	35-36
Candlestick Sensor .....	37
ISD™ .....	38
ISD-232™ .....	39
thermVIEW™ .....	40-42
thermKIT™ .....	43
PTM-1000™ .....	44
PTB-1000™ .....	45
WTC-100™ .....	46
CLWTC-1000™ .....	47
HP-97™ .....	48
CIP-1000™ .....	49
HFC-100™ .....	50
FCM-100™ .....	51
Wind Tunnels .....	52
CLWT-100™ .....	53
CLWT-067™ .....	54
CWT-108™ .....	55
CWT-107™ .....	56
CWT-106™ .....	57
CWT-100™ .....	58
BWT-104™ .....	59
BWT-100™ .....	60

# ATS Heat Sink Solutions

The Only Heat Sink For Tough To Cool Electronics

We think "inside" the box



Innovation in Thermal Management™

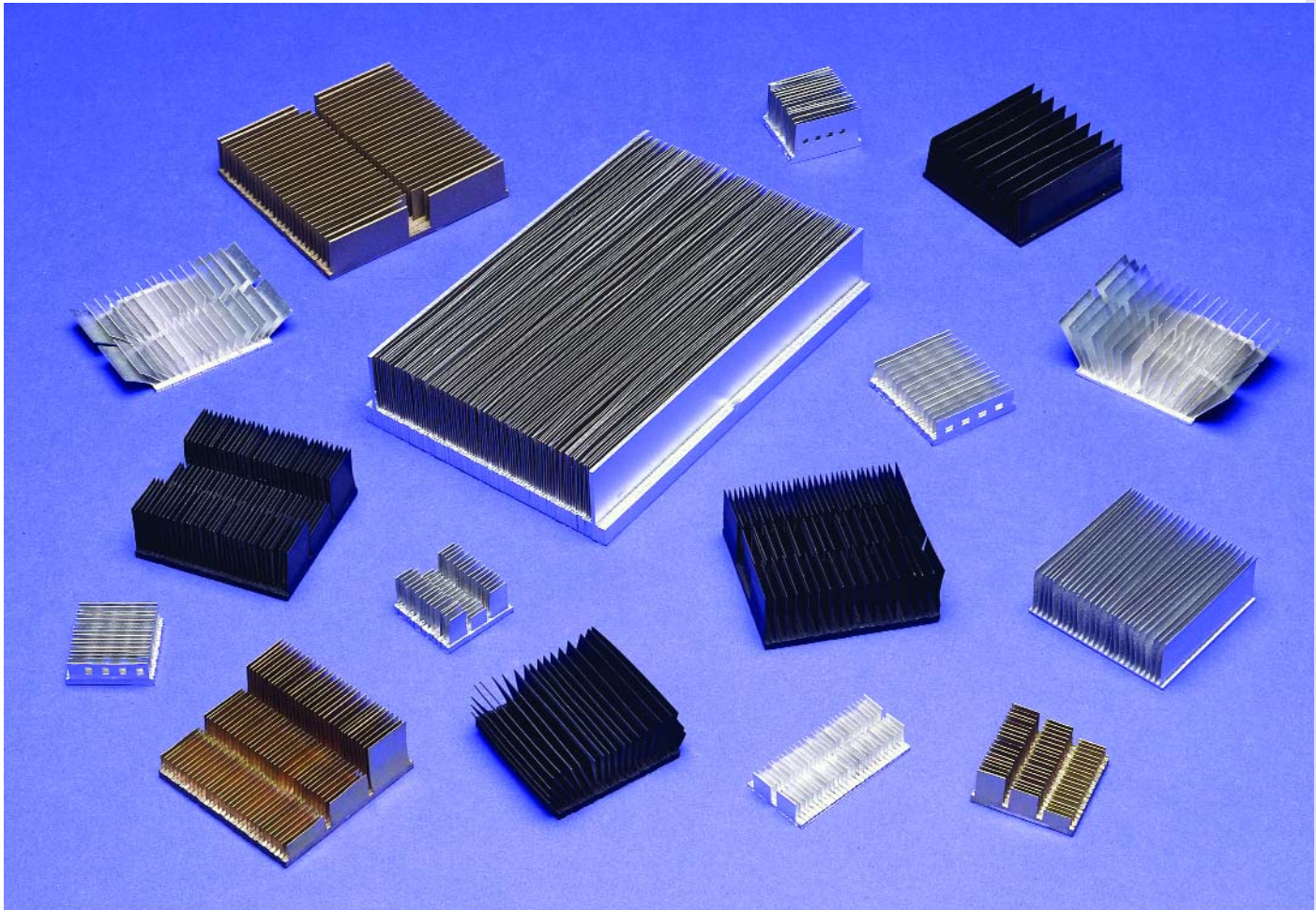

- **Ultra Performance**
  - **Low Profile**
  - **Light Weight**

**ATS** - *The Designer and Manufacturer of the Most Advanced Heat Sinks with the Highest Performance*

**Advanced Thermal Solutions, Inc.**

89-27 Access Road, Norwood, MA 02062 USA  
Tel: 781-769-2800 / Fax: 781-769-9979 / Email: ats@qats.com / www.qats.com

© All Rights Reserved

# Heat Sink Comparison



Innovation in Thermal Management™



Vendor	P	T <sub>amb</sub>	R <sub>sa</sub> @200 LFM	T <sub>j</sub>
<b>ATS</b>	<b>50W</b>	<b>25°C</b>	<b>1.6</b>	<b>105°C</b>
<b>Competition</b>	<b>50W</b>	<b>25°C</b>	<b>3.0</b>	<b>175°C</b>

## Measuring The Impact Of Higher Thermal Resistance

The equation below is used to calculate the junction temperature of the device:

$$R_{ja} = R_{jc} + R_{cs} + R_{sa}$$

and

$$R_{ja} = (T_j - T_{amb})/P$$

Solving for T<sub>j</sub>:  $T_j = R_{sa} * P + T_{amb}$

Where:

P = Device Power Dissipation

R<sub>sa</sub> = Heatsink Thermal Resistance (°C/W)

R<sub>cs</sub> = Device Case To Heatsink Base Thermal Resistance (Interface Material)

R<sub>ja</sub> = Device Junction-To-Ambient Thermal Resistance

R<sub>jc</sub> = Device Junction-To-Case Thermal Resistance

T<sub>amb</sub> = Ambient Temperature

T<sub>j</sub> = Device Junction Temperature (Critical Parameter)

### ATS BGA Heatsink ATS-97-09-034B

#### Dimensions

Height:	16.5mm
Width:	45mm
Length:	45mm

#### Note on Testing

Interface Material is T405

#### Method of Attachment

Double sided conductive tape

**Weight:** 11 gm

#### Thermal Resistance (R<sub>ca</sub>)

Velocity	°C/W
100	3.4
200	2.1
400	1.3
600	1.0
700	0.9

### Competitions' BGA Heatsink

#### Dimensions

Height:	15.49mm
Width:	47.62 Circular
Length:	**

#### Note on Testing

Interface Material was Cool Link™ (thermal grease, 2 to 3 times better than T405)

#### Method of Attachment

Surround clip with phase change material at the interface

**Weight:** 52.25 gm

#### Thermal Resistance (R<sub>ca</sub>)

Velocity	°C/W
100	4.3 Ext.
200	3.0
400	1.8
600	1.4
700	1.3

To better understand how hot the T<sub>j</sub> can get and why high performance heat sinks are important, compare T<sub>j</sub> with the temperature of boiling water. Since water boils at 100°C (212°F), the junction temperature can be significantly above that of water boiling at sea level. Other considerations include device and system operational and marketing standpoints. Given that the expected life of an electronic part is exponentially dependent on temperature, cooler parts will have longer life. Systems with better reliability provide better market appeal. This can be attained by improved heat sinks while the system operates with lower air flow velocity within the system.

In short, a higher-performance heatsink will result in not only a reliable product with longer life, but also enhances product market appeal.

### ATS Design Impact

Velocity	% of Improvement of R <sub>ca</sub>
<b>100</b>	<b>26%</b>
<b>200</b>	<b>42%</b>
<b>400</b>	<b>30%</b>
<b>600</b>	<b>41%</b>
<b>700</b>	<b>44%</b>

*Remember, less is better*

### Advanced Thermal Solutions, Inc.

89-27 Access Road, Norwood, MA 02062 USA

Tel: 781-769-2800 / Fax: 781-769-9979 / Email: ats@qats.com / www.qats.com

© All Rights Reserved

# BGA Cooling Solutions



Innovation in Thermal Management™

## MaxiFLOW™ HIGH PERFORMANCE, LOW PROFILE & LIGHTWEIGHT

Cool BGA packages with the latest patented compact high performance heat sinks



ATS-EX1

H(mm):	velocity ft/min	resistance (C°W)
9.0		
W: 30.0	100	5.8
	200	4.0
L: 30.0	400	2.6
weight gr: 10.0	600	2.0

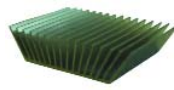

ATS-34B-EX

H(mm):	velocity ft/min	resistance (C°W)
15.0		
W: 45.0	100	3.8
	200	2.4
L: 45.0	400	1.7
weight gr: 34.0	600	1.3

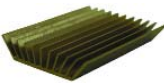

ATS-EX2A

H(mm):	velocity ft/min	resistance (C°W)
9.0		
W: 30.0	100	5.3
	200	3.7
L: 58.0	400	2.3
weight gr: 18.0	600	1.7



ATS97-09-034B

H(mm):	velocity ft/min	resistance (C°W)
16.3		
W: 45.0	100	3.4
	200	2.1
L: 50.0	400	1.3
weight gr: 23.0	600	1.0



ATS-EX2

H(mm):	velocity ft/min	resistance (C°W)
9.0		
W: 30.0	100	5.5
	200	3.9
L: 58.0	400	2.4
weight gr: 16.0	600	1.8

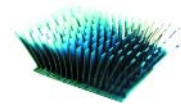

ATS97-09-034B P2

H(mm):	velocity ft/min	resistance (C°W)
16.3		
W: 45.0	100	3.6
	200	2.3
L: 50.0	400	1.4
weight gr: 20.0	600	1.1



ATS-EX3

H(mm):	velocity ft/min	resistance (C°W)
5.0		
W: 30.0	100	7.8
	200	6.1
L: 58.0	400	4.5
weight gr: 14.0	600	3.4



ATS97-09-037A

H(mm):	velocity ft/min	resistance (C°W)
8.5		
W: 45.0	100	6.8
	200	4.8
L: 50.0	400	3.1
weight gr: 14.0	600	2.4

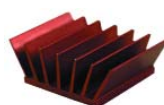

ATS-EX4

H(mm):	velocity ft/min	resistance (C°W)
9.0		
W: 26.0	100	7.8
	200	5.3
L: 19.0	400	3.4
weight gr: 4.0	600	2.7



ATS97-09-037B

H(mm):	velocity ft/min	resistance (C°W)
8.5		
W: 45.0	100	5.8
	200	4.0
L: 45.0	400	2.6
weight gr: 16.0	600	2.0



ATS-EX5

H(mm):	velocity ft/min	resistance (C°W)
4.0		
W: 25.4	100	12.0
	200	9.0
L: 25.4	400	6.0
weight gr: 4.0	600	5.0



ATS99-10-100

H(mm):	velocity ft/min	resistance (C°W)
25.0		
W: 50.0	100	2.8
	200	1.3
L: 50.0	400	0.6
weight gr: 38.0	600	0.6



ATS-EX7

H(mm):	velocity ft/min	resistance (C°W)
9.0		
W: 15.0	100	17.0
	200	12.0
L: 15.0	400	7.8
weight gr: 4.0	600	6.0

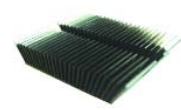

ATS99-11-103

H(mm):	velocity ft/min	resistance (C°W)
12.5		
W: 57.5	100	3.6
	200	2.3
L: 57.5	400	1.3
weight gr: 24.0	600	1.0

**A Full Line of BGA Heat Sinks for Superior Performance**

Thermal performance exceeding extruded equivalents by 4 fold.

ATS's patented technology provides High Fin density design with maximum cooling per unit volume.

Light weight heat sinks eliminate the need for mechanical attachments. Some mechanical attachment methods have caused cracking of the silicon.

Low profile maxiFLOW™ heat sinks are ideally suited for today's compact electronics.

ATS custom designs maxiFLOW™ heat sinks for each individual application.

ATS also produces high performing heat sinks for low air velocity applications.

ATS designs & manufactures the most advanced heat sinks for cooling BGA packages. ATS will custom design heat sinks per your specific design requirements.

**Advanced Thermal Solutions, Inc.**

89-27 Access Road, Norwood, MA 02062 USA

Tel: 781-769-2800 / Fax: 781-769-9979 / Email: ats@qats.com / www.qats.com

© All Rights Reserved



ATS00-12-134 & ATS00-12-134A

H(mm):	Velocity (ft/min)	Resistance C°/W
4.0	100	18.8
W: 25.2	200	14.8
	400	9.6
L: 25.2	600	6.9

ATS00-12-135

H(mm):	Velocity (ft/min)	Resistance C°/W
4.0	100	9.9
W: 37.6	200	7.8
	400	4.9
L: 37.6	600	3.6

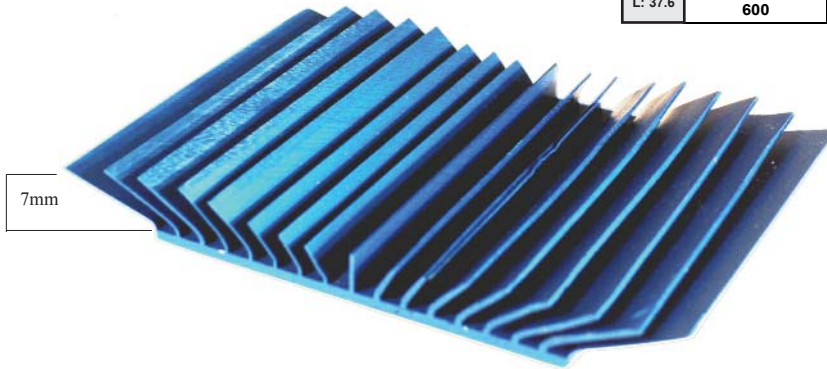

ATS01-00-136

H(mm):	Velocity (ft/min)	Resistance C°/W
7.0	100	3.95
W: 58.2	200	2.88
	400	1.8
L: 61.0	600	1.23

Note: W is base width.

- Low profile
- High performance
- Low velocity
- Reduces assembly time
- Saves valuable space

**Advanced Thermal Solutions** introduces **blueICE™**, a family of low profile heat sinks ranging in height from 4 to 7 mm are produced for tough to cool electronic components. These high performance heat sinks are designed for low air velocity flows. This suits most telecommunication applications where space is limited.

Since these heat sinks are very light weight (4, 10, & 30gr.), no mechanical attachment is needed and a double-sided thermal adhesive tape will attach the heat sink to the component. This reduces assembly time and saves valuable space on the board.

# blackDIAMOND™

the passive cooling solution for intel's Xeon processor



Innovation in Thermal Management™

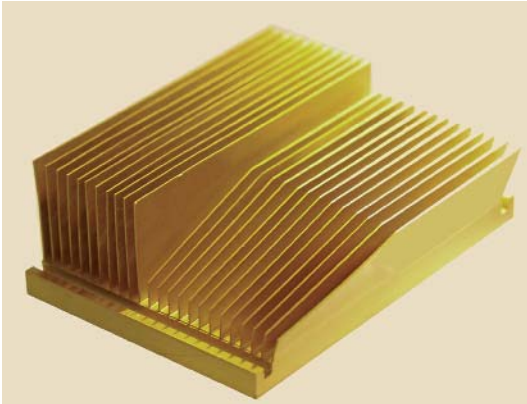

Advanced Thermal Solutions (ATS) presents the blackDIAMOND™ family of heat sinks for passive cooling (non-fansink) of high-powered processors.

## ATS088063030-148

	Velocity (ft/min)	Resistance °C/W
H: 30mm	100	1.85
	200	1.03
W: 64mm	400	0.54
	600	0.42
L: 89mm	800	0.40

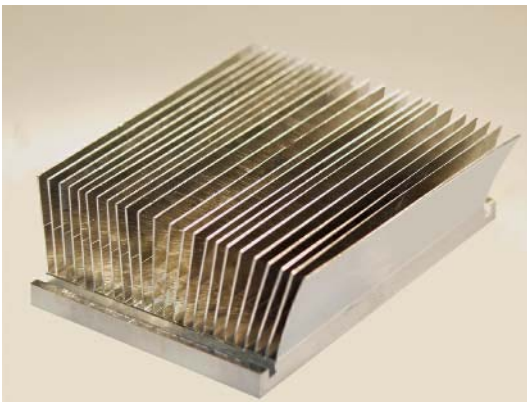

## ATS088063030-148-1

	Velocity (ft/min)	Resistance °C/W
H: 30mm	100	1.68
	200	0.92
W: 64mm	400	0.48
	600	0.39
L: 89mm	800	0.34

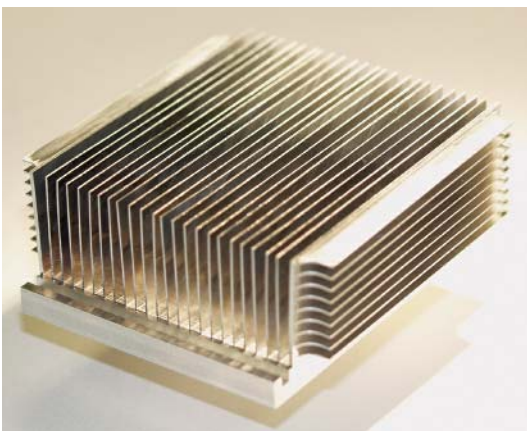

## ATS088063030-148-3

	Velocity (ft/min)	Resistance °C/W
H: 30mm	100	1.90
	200	0.92
W: 64mm	400	0.46
	600	0.35
L: 89mm	800	0.31

**ATS** will custom design and manufacture a heat sink that is best suited for your specific application. By providing your system and thermal requirements to our Engineering Department, we will present a design to you within 24 hours.

### Advanced Thermal Solutions, Inc.

89-27 Access Road, Norwood, MA 02062 USA  
Tel: 781-769-2800 / Fax: 781-769-9979 / Email: ats@qats.com / www.qats.com

© All Rights Reserved





## Heat Sinks

The powerICE™ family of low profile, high performance heat sinks is designed to optimize the thermal management of PCB-mounted power modules in spatially constrained applications having inadequate airflow. Using the patented powerICE™ heat sinks enables circuit designers to achieve higher PCB performance levels than possible with conventional, over-sized heat sinks. Ideal for bypassed and unducted flow conditions, compact powerICE™ heat sinks save space, and their light weight helps reduce costs by eliminating the need for supplemental mechanical mounting clips. powerICE™ heat sinks can be customized for any power module.

powerICE™ heat sinks utilize a patented design that outperforms conventional heat sinks in comparable applications and eliminates packaging problems associated with over-sized heat sinks that may have excessive spreading resistance.

**For use with Power Module DC-DC Converters (e.g. TYCO- JFW050F, JFW075F, JFW100F, JFW150F)**

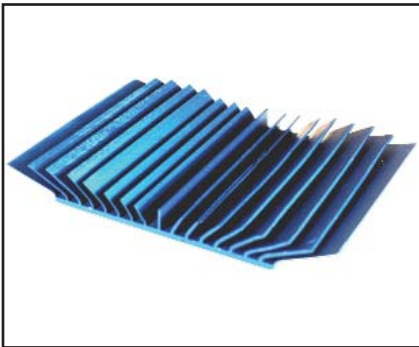

**ATS01-00-136 and 136A**

	Vel.(ft/min)	Res.(R <sub>ea</sub> )
H: 7mm	100	3.95
W: 58mm	200	2.88
L: 61mm	400	1.80
	600	1.23

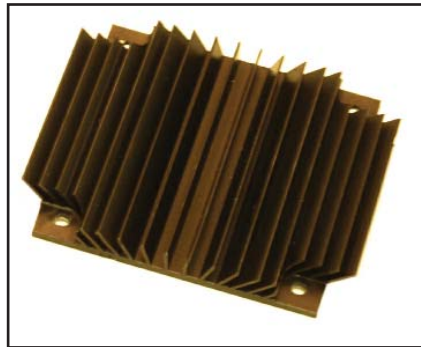

**ATS061058006-136C**

	Vel.(ft/min)	Res.(R <sub>ea</sub> )
H: 6mm	100	4.37
W: 58mm	200	3.55
L: 61mm	400	2.43
	600	1.99



**ATS061058005-136D**

	Vel.(ft/min)	Res.(R <sub>ea</sub> )
H: 6mm	100	4.76
W: 58mm	200	3.55
L: 61mm	400	2.43
	600	1.99



**ATS061058006-178**

	Vel.(ft/min)	Res.(R <sub>ea</sub> )
H: 6mm	100	5.75
W: 58mm	200	4.86
L: 61mm	400	3.39
	600	2.46

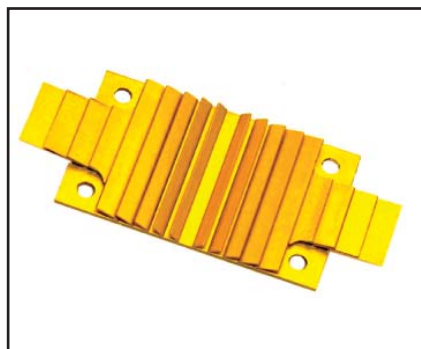

**ATS036058004-184**

	Vel.(ft/min)	Res.(R <sub>ea</sub> )
H: 5mm	100	7.26
W: 58mm	200	6.54
L: 36mm	400	3.92
	600	2.96



**ATS036058004-202**

	Vel.(ft/min)	Res.(R <sub>ea</sub> )
H: 4mm	100	14.0
W: 58mm	200	8.89
L: 36mm	400	5.76
	600	3.62

**Advanced Thermal Solutions, Inc.**

89-27 Access Road, Norwood, MA 02062 USA  
 Tel: 781-769-2800 / Fax: 781-769-9979 / Email: ats@qats.com / www.qats.com

# Pin Fin

## Extrusion Heat Sinks



Innovation in Thermal Management™

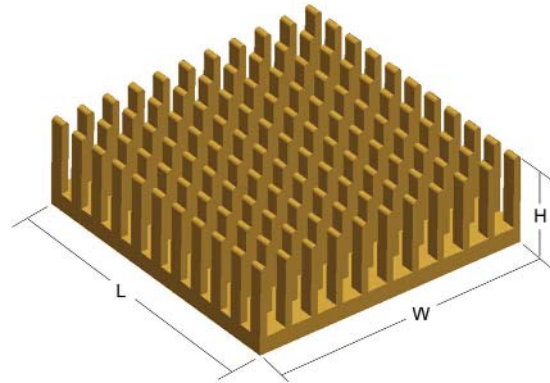

	L (mm)	W (mm)	H (mm)																									
1	10	10	2	3	4	5	6	7	8	9	10	11	12	13	14	15	16	17	18	19	20	21	22	23	24	25		
2	12	12	2	3	4	5	6	7	8	9	10	11	12	13	14	15	16	17	18	19	20	21	22	23	24	25		
3	14	14	2	3	4	5	6	7	8	9	10	11	12	13	14	15	16	17	18	19	20	21	22	23	24	25		
4	15	15	2	3	4	5	6	7	8	9	10	11	12	13	14	15	16	17	18	19	20	21	22	23	24	25		
5	17	17	2	3	4	5	6	7	8	9	10	11	12	13	14	15	16	17	18	19	20	21	22	23	24	25		
6	19	19	2	3	4	5	6	7	8	9	10	11	12	13	14	15	16	17	18	19	20	21	22	23	24	25		
7	20	20	2	3	4	5	6	7	8	9	10	11	12	13	14	15	16	17	18	19	20	21	22	23	24	25		
8	24	24	2	3	4	5	6	7	8	9	10	11	12	13	14	15	16	17	18	19	20	21	22	23	24	25		
9	28	28	2	3	4	5	6	7	8	9	10	11	12	13	14	15	16	17	18	19	20	21	22	23	24	25		
10	31	31	2	3	4	5	6	7	8	9	10	11	12	13	14	15	16	17	18	19	20	21	22	23	24	25		
11	35	35	2	3	4	5	6	7	8	9	10	11	12	13	14	15	16	17	18	19	20	21	22	23	24	25		
12	37	37	2	3	4	5	6	7	8	9	10	11	12	13	14	15	16	17	18	19	20	21	22	23	24	25		
13	40	40	2	3	4	5	6	7	8	9	10	11	12	13	14	15	16	17	18	19	20	21	22	23	24	25		
14	42	42	2	3	4	5	6	7	8	9	10	11	12	13	14	15	16	17	18	19	20	21	22	23	24	25		
15	45	45	2	3	4	5	6	7	8	9	10	11	12	13	14	15	16	17	18	19	20	21	22	23	24	25		
16	60	60	2	3	4	5	6	7	8	9	10	11	12	13	14	15	16	17	18	19	20	21	22	23	24	25		
			A	B	C	D	E	F	G	H	I	J	K	L	M	N	O	P	Q	R	S	T	U	V	W	X		

### HOW TO ORDER:

- Identify L,W, H of the heat sink suitable for your application
- Find the correct part number: **e.g. For a 19L, 19W, 15H (mm) heat sink the number is**  
**ATS019019015-PF-6N**
  - Use letters "PF" denoting **Pin Fin** style
  - Record the number in the leftmost column- **6**
  - Record the letter in the bottom row- **N**
- Then visit our website or call for performance & pricing using **ATS019019015-PF-6N**  
[www.qats.com](http://www.qats.com), Tel: 781-769-2800

### Advanced Thermal Solutions, Inc.

89-27 Access Road, Norwood, MA 02062 USA  
 Tel: 781-769-2800 / Fax: 781-769-9979 / Email: [ats@qats.com](mailto:ats@qats.com) / [www.qats.com](http://www.qats.com)

© All Rights Reserved

# Straight Fin

## High Performance Extrusion



Innovation in Thermal Management™

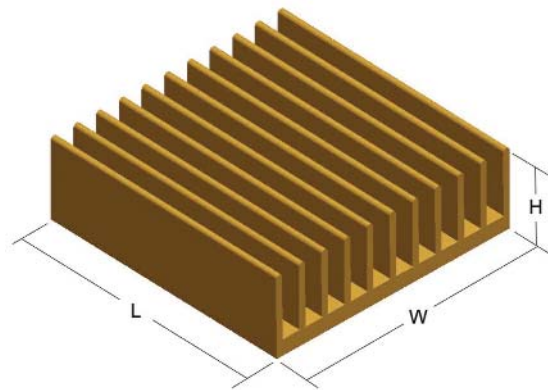

	L (mm)	W (mm)	H (mm)																							
1	10	10	2	3	4	5	6	7	8	9	10	11	12	13	14	15	16	17	18	19	20	21	22	23	24	25
2	12	12	2	3	4	5	6	7	8	9	10	11	12	13	14	15	16	17	18	19	20	21	22	23	24	25
3	14	14	2	3	4	5	6	7	8	9	10	11	12	13	14	15	16	17	18	19	20	21	22	23	24	25
4	15	15	2	3	4	5	6	7	8	9	10	11	12	13	14	15	16	17	18	19	20	21	22	23	24	25
5	17	17	2	3	4	5	6	7	8	9	10	11	12	13	14	15	16	17	18	19	20	21	22	23	24	25
6	19	19	2	3	4	5	6	7	8	9	10	11	12	13	14	15	16	17	18	19	20	21	22	23	24	25
7	20	20	2	3	4	5	6	7	8	9	10	11	12	13	14	15	16	17	18	19	20	21	22	23	24	25
8	24	24	2	3	4	5	6	7	8	9	10	11	12	13	14	15	16	17	18	19	20	21	22	23	24	25
9	28	28	2	3	4	5	6	7	8	9	10	11	12	13	14	15	16	17	18	19	20	21	22	23	24	25
10	31	31	2	3	4	5	6	7	8	9	10	11	12	13	14	15	16	17	18	19	20	21	22	23	24	25
11	35	35	2	3	4	5	6	7	8	9	10	11	12	13	14	15	16	17	18	19	20	21	22	23	24	25
12	37	37	2	3	4	5	6	7	8	9	10	11	12	13	14	15	16	17	18	19	20	21	22	23	24	25
13	40	40	2	3	4	5	6	7	8	9	10	11	12	13	14	15	16	17	18	19	20	21	22	23	24	25
14	42	42	2	3	4	5	6	7	8	9	10	11	12	13	14	15	16	17	18	19	20	21	22	23	24	25
15	45	45	2	3	4	5	6	7	8	9	10	11	12	13	14	15	16	17	18	19	20	21	22	23	24	25
16	60	60	2	3	4	5	6	7	8	9	10	11	12	13	14	15	16	17	18	19	20	21	22	23	24	25
			A	B	C	D	E	F	G	H	I	J	K	L	M	N	O	P	Q	R	S	T	U	V	W	X

### HOW TO ORDER:

- Identify L,W, H of the heat sink suitable for your application
- Find the correct part number: **e.g. For a 19L, 19W, 15H (mm) heat sink the number is AT019019015-SF-6N**
  - Use letters "SF" denoting **straight fin** style
  - Record the number in the leftmost column- **6**
  - Record the letter in the bottom row- **N**
- Then visit our website or call for performance & pricing using **AT019019015-SF-6N**  
www.qats.com, Tel: 781-769-2800

### Advanced Thermal Solutions, Inc.

89-27 Access Road, Norwood, MA 02062 USA  
Tel: 781-769-2800 / Fax: 781-769-9979 / Email: ats@qats.com / www.qats.com

© All Rights Reserved

# Cross Cut Heatsinks



Innovation in Thermal Management™

Part No.	L - mm (in.)	W - mm (in.)	H - mm (in.)	Finish	Pin Array
ATS021021006-PF010	21 (.827)	21 (.827)	6.4 (.25)	BLACK ANODIZE	6 X 6
ATS021021009-PF011	21 (.827)	21 (.827)	8.9 (.35)	BLACK ANODIZE	6 X 6
ATS021021011-PF012	21 (.827)	21 (.827)	11.4 (.45)	BLACK ANODIZE	6 X 6
ATS021021015-PF013	21 (.827)	21 (.827)	15.2 (.6)	BLACK ANODIZE	6 X 6
ATS025025006-PF014	25 (.984)	25 (.984)	6.4 (.25)	BLACK ANODIZE	7 X 7
ATS025025009-PF015	25 (.984)	25 (.984)	8.9 (.35)	BLACK ANODIZE	7 X 7
ATS025025011-PF016	25 (.984)	25 (.984)	11.4 (.45)	BLACK ANODIZE	7 X 7
ATS025025015-PF017	25 (.984)	25 (.984)	15.2 (.6)	BLACK ANODIZE	7 X 7
ATS028028006-PF018	27.9 (1.1)	27.9 (1.1)	6.4 (.25)	BLACK ANODIZE	7 X 8
ATS028028009-PF019	27.9 (1.1)	27.9 (1.1)	8.9 (.35)	BLACK ANODIZE	7 X 8
ATS028028011-PF020	27.9 (1.1)	27.9 (1.1)	11.4 (.45)	BLACK ANODIZE	7 X 8
ATS028028015-PF021	27.9 (1.1)	27.9 (1.1)	15.2 (.6)	BLACK ANODIZE	7 X 8
ATS035035006-PF022	35 (1.378)	35 (1.378)	6.4 (.25)	BLACK ANODIZE	11 X 11
ATS035035009-PF023	35 (1.378)	35 (1.378)	8.9 (.35)	BLACK ANODIZE	11 X 11
ATS035035011-PF024	35 (1.378)	35 (1.378)	11.4 (.45)	BLACK ANODIZE	11 X 11
ATS035035015-PF025	35 (1.378)	35 (1.378)	15.2 (.6)	BLACK ANODIZE	11 X 11
ATS041041007-PF026	40.6 (1.6)	40.6 (1.6)	6.6 (.26)	BLACK ANODIZE	11 X 11
ATS041041013-PF027	40.6 (1.6)	40.6 (1.6)	13.3 (.525)	BLACK ANODIZE	11 X 11
ATS044044004-PF028	43.5 (1.713)	43.5 (1.713)	3.8 (.15)	BLACK ANODIZE	12 X 14
ATS043045005-PF029	44.5 (1.75)	43.2 (1.7)	5.1 (.2)	BLACK ANODIZE	11 X 10
ATS043045006-PF030	44.5 (1.75)	43.2 (1.7)	6.4 (.25)	BLACK ANODIZE	11 X 10
ATS043045009-PF031	44.5 (1.75)	43.2 (1.7)	8.9 (.35)	BLACK ANODIZE	11 X 10
ATS043045010-PF032	44.5 (1.75)	43.2 (1.7)	10.2 (.4)	BLACK ANODIZE	11 X 10
ATS043045016-PF033	44.5 (1.75)	43.2 (1.7)	16.5 (.65)	BLACK ANODIZE	11 X 10
ATS048054010-PF034	53.3 (2.1)	47.2 (1.86)	10.2 (.40)	BLACK ANODIZE	11 X 11
ATS048054016-PF035	53.3 (2.1)	47.2 (1.86)	16.5 (.65)	BLACK ANODIZE	11 X 11
ATS048054020-PF036	53.3 (2.1)	47.2 (1.86)	20.3 (.8)	BLACK ANODIZE	11 X 11
ATS048054025-PF037	53.3 (2.1)	47.2 (1.86)	25.4 (1)	BLACK ANODIZE	11 X 11
ATS054054010-PF038	53.3 (2.1)	53.3 (2.1)	10.2 (0.4)	BLACK ANODIZE	11 X 12
ATS054054016-PF039	53.3 (2.1)	53.3 (2.1)	16.5 (0.65)	BLACK ANODIZE	11 X 12
ATS054054020-PF040	53.3 (2.1)	53.3 (2.1)	20.3 (0.8)	BLACK ANODIZE	11 X 12
ATS054054025-PF041	53.3 (2.1)	53.3 (2.1)	25.4 (1)	BLACK ANODIZE	11 X 12

## Advanced Thermal Solutions, Inc.

89-27 Access Road, Norwood, MA 02062 USA

Tel: 781-769-2800 / Fax: 781-769-9979 / Email: ats@qats.com / www.qats.com

© All Rights Reserved

# maxiFlow™

## Ultra Performance Extrusion



Innovation in Thermal Management™

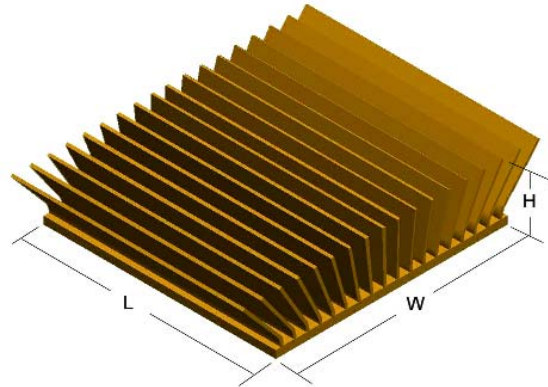

	L (mm)	W (mm)	H (mm)																							
1	10	10	2	3	4	5	6	7	8	9	10	11	12	13	14	15	16	17	18	19	20	21	22	23	24	25
2	12	12	2	3	4	5	6	7	8	9	10	11	12	13	14	15	16	17	18	19	20	21	22	23	24	25
3	14	14	2	3	4	5	6	7	8	9	10	11	12	13	14	15	16	17	18	19	20	21	22	23	24	25
4	15	15	2	3	4	5	6	7	8	9	10	11	12	13	14	15	16	17	18	19	20	21	22	23	24	25
5	17	17	2	3	4	5	6	7	8	9	10	11	12	13	14	15	16	17	18	19	20	21	22	23	24	25
6	19	19	2	3	4	5	6	7	8	9	10	11	12	13	14	15	16	17	18	19	20	21	22	23	24	25
7	20	20	2	3	4	5	6	7	8	9	10	11	12	13	14	15	16	17	18	19	20	21	22	23	24	25
8	24	24	2	3	4	5	6	7	8	9	10	11	12	13	14	15	16	17	18	19	20	21	22	23	24	25
9	28	28	2	3	4	5	6	7	8	9	10	11	12	13	14	15	16	17	18	19	20	21	22	23	24	25
10	31	31	2	3	4	5	6	7	8	9	10	11	12	13	14	15	16	17	18	19	20	21	22	23	24	25
11	35	35	2	3	4	5	6	7	8	9	10	11	12	13	14	15	16	17	18	19	20	21	22	23	24	25
12	37	37	2	3	4	5	6	7	8	9	10	11	12	13	14	15	16	17	18	19	20	21	22	23	24	25
13	40	40	2	3	4	5	6	7	8	9	10	11	12	13	14	15	16	17	18	19	20	21	22	23	24	25
14	42	42	2	3	4	5	6	7	8	9	10	11	12	13	14	15	16	17	18	19	20	21	22	23	24	25
15	45	45	2	3	4	5	6	7	8	9	10	11	12	13	14	15	16	17	18	19	20	21	22	23	24	25
16	60	60	2	3	4	5	6	7	8	9	10	11	12	13	14	15	16	17	18	19	20	21	22	23	24	25
			A	B	C	D	E	F	G	H	I	J	K	L	M	N	O	P	Q	R	S	T	U	V	W	X

### HOW TO ORDER:

- Identify L, W, H of the heat sink suitable for your application
- Find the correct part number: **e.g. For a 19L, 19W, 15H (mm) heat sink the number is **ATS019019015-MF-6N****
  - Use letters "MF" denoting **maxiFLOW™** style
  - Record the number in the leftmost column- **6**
  - Record the letter in the bottom row- **N**
- Then visit our website or call for performance & pricing using **ATS019019015-MF-6N**  
www.qats.com, Tel: 781-769-2800

### Advanced Thermal Solutions, Inc.

89-27 Access Road, Norwood, MA 02062 USA  
Tel: 781-769-2800 / Fax: 781-769-9979 / Email: ats@qats.com / www.qats.com

© All Rights Reserved



# Ultra High Performance BGA Cooling Solutions w/ Thermal Tape Attachment

**ATS PART # ATS-52350B-C2-R0**

## Features & Benefits

- » maxiFLOW™ design features a low profile, spread fin array that maximizes surface area for more effective convection (air) cooling
- » Fabricated from extruded aluminum, which minimizes thermal resistance from the base to the fins, reduces weight and keeps costs low
- » Higher performance helps ensure reliable product life at a lower cost than other extruded heat sinks

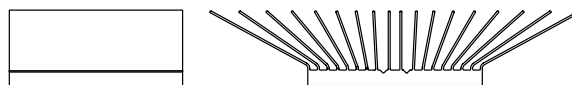
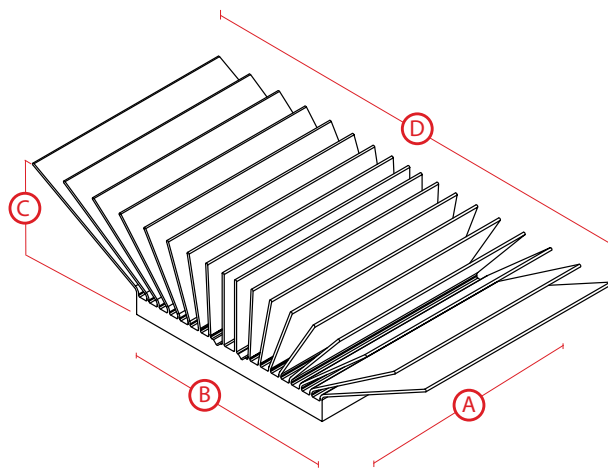

*\*Image above is for illustration purposes only.*

## Thermal Performance

AIR VELOCITY		THERMAL RESISTANCE	
FT/MIN	M/S	°C/W (UNDUCTED FLOW)	°C/W (DUCTED FLOW)
200	1.0	5.3	3.4
300	1.5	3.9	
400	2.0	3.2	
500	2.5	2.9	
600	3.0	2.6	
700	3.5	2.4	
800	4.0	2.2	

## Product Details

DIMENSION A	DIMENSION B	DIMENSION C	DIMENSION D	INTERFACE MATERIAL	FINISH
35 mm	35 mm	7.5 mm	44.9 mm	SAINT-GOBAIN C675	BLUE-ANODIZED

### NOTES:

- 1) Dimension C = heat sink height from bottom of the base to the top of the fin field.
- 2) Thermal performance data are provided for reference only. Actual performance may vary by application.
- 3) ATS reserves the right to update or change its products without notice to improve the design or performance.
- 4) Contact ATS to learn about custom options available.



**ATS** ADVANCED THERMAL SOLUTIONS, INC.  
Innovations in Thermal Management®

**For more information, to find a distributor or to place an order, visit [www.qats.com](http://www.qats.com) or call: 781.769.2800 (North America); +31 (0) 3569 84715 (Europe).**

# Clip N' Cool

## The Ultimate Heat Sink Attachment Solution

**maxiGRIP™** is a patent-pending frame clip and metal spring clip to secure heat sinks to IC's. The product line is diverse enough to handle the increasing power requirements of today's advanced circuits that run at higher frequencies and are mounted on higher density boards. These BGA's are commonly used in today's telecom, server, storage and other electronic products.

### Advantages

Advanced Thermal Solutions, Inc. exclusive heat sink and clip assembly allows for quick and easy installation and removal whenever it is needed. Due to this unique design we can provide superb cooling, with a wide array of heat sinks, without the hassle of cracking the dies or ripping the component from the PCB during installation.

### Application

Quick and easy installation and removal.

1. Place frame clip
2. Set heat sink
3. Snap the spring clip

### Removal

Simply reverse the steps described above.

### Sizes Available

- 42 x 42 mm
- 29 x 29 mm
- 25 x 25 mm
- 21 x 21 mm

Please contact us for custom clip and cooling designs.

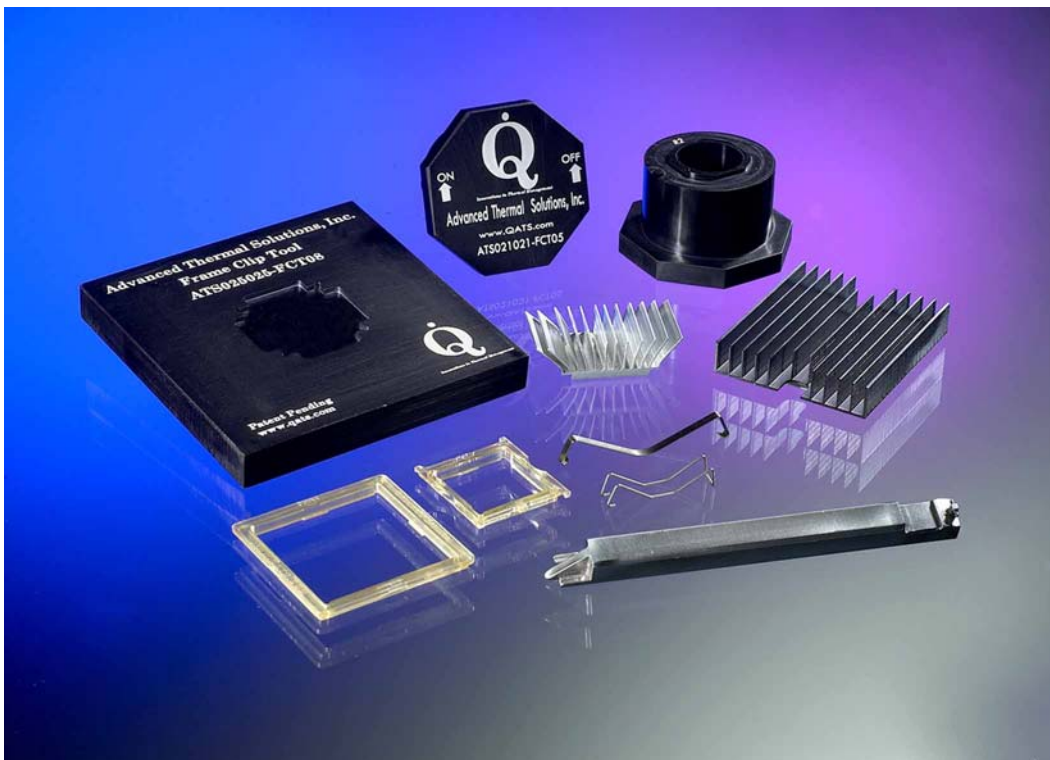
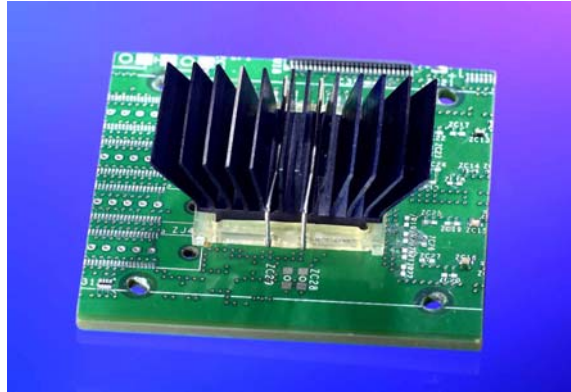

[www.qats.com](http://www.qats.com)



Innovation in Thermal Management™

- No threading required. No cracking of die easy on, easy off clip combinations with superb performance
- Clip attachment tool: makes installation & removal a breeze.
- The unique clip design minimizes the effect of creep resulting in a long-lasting, dependable attachment.
- Meets NEBS testing requirements.
- Meets shock and vibration standards. Secures heat sink to component with uniform pressure for consistent thermal performance.
- The secured heat sink attachment results in superior thermal performance.
- Permits overhang of the heat sink on a component, extending the cooling surface.
- Frame and spring clips have negligible effect on air flow.
- Adaptable to a wide spectrum of heat sinks including those designed for high efficiency outputs.
- Doesn't need adjusting to obtain maximum contact area.
- **maxiGRIP™** neither rips the component off the PCB nor cracks the die during installation.

# maxiGRIP™

## The Ultimate Heat Sink Attachment Solution

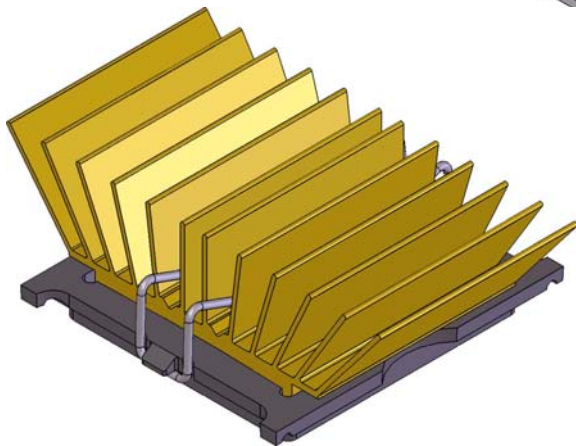
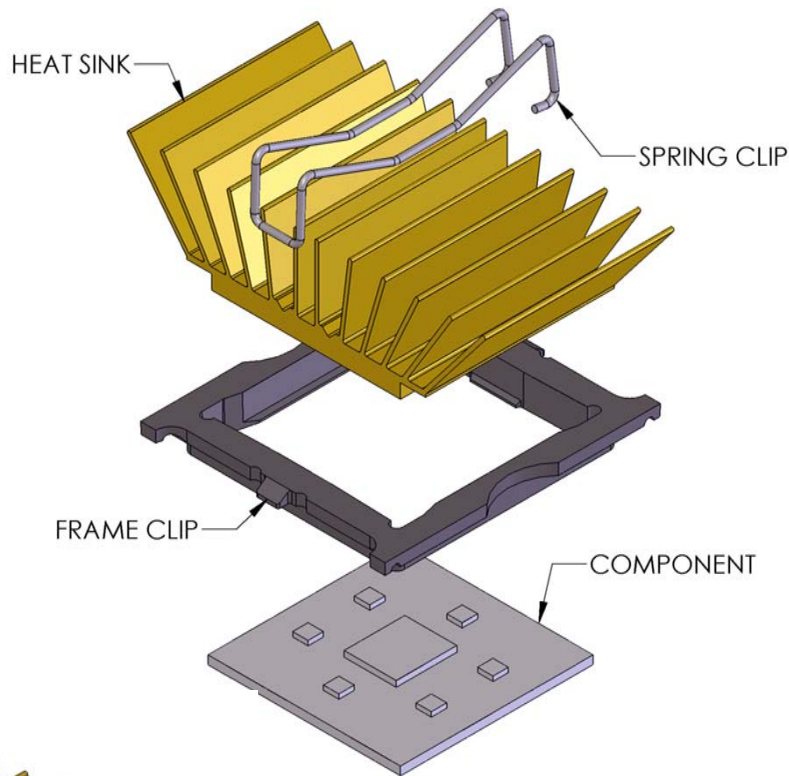
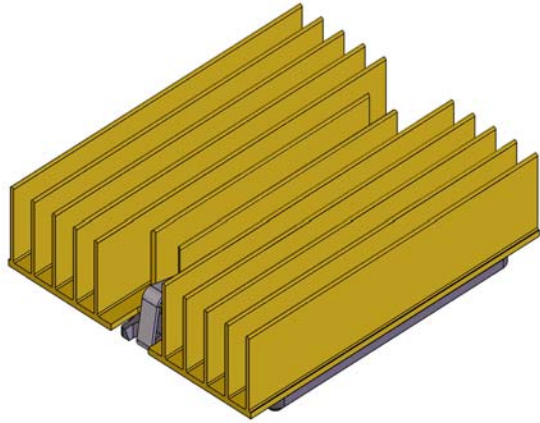

### Advanced Thermal Solutions

89-27 Access Road  
Norwood, MA 02062  
Tel: 781.769.2800 / Fax: 781.769.9979  
Email: info@qats.com © All Rights Reserved  
[www.qats.com](http://www.qats.com)



Innovation in Thermal Management™

Advanced Thermal Solutions, Inc. is a cutting-edge, one-stop thermal design/engineering/manufacturing company, with offices in the US & Holland. We provide the following products and services:

#### Cooling Solutions

- Liquid cooling solutions (0.02 C°/W CPU cold-plate)
- Custom, standard, & high performance heat sinks
- *maxFLOW™*, straight fin, pin fin heat sinks

#### Consulting services

- Analytical modeling
- CFD simulation
- Water flow testing
- JEDEC testing
- Thermal characterization of ICs, heat sinks, cold plates, PC boards and chasses
- Fan selection and its performance management

#### Test equipment

- Hot wire anemometers
- Wind tunnels and controllers
- Liquid crystal thermography
- High heat flux controller
- Precision temperature and pressure sensors

#### Other products and services

- Liquid cooling systems
- High capacity cooling solutions
- Fan trays for high powered laser and telecom applications





# High Performance BGA Cooling Solutions with maxiGRIP™ Attachment

**ATS PART # ATS-53350B-C1-R0**

## Features & Benefits

- » High aspect ratio, straight fin heat sinks that are ideal for compact PCB environments
- » maxiGRIP™ attachment applies steady, even pressure to the component and does not require holes in the PCB
- » Designed specifically for BGAs and other surface mount packages
- » Meets Telcordia GR-63-Core Office Vibration, ETSI 300 019 Transportation Vibration, and MIL-STD-810 Shock testing and Unpackaged Drop Testing standards
- » Comes preassembled with high performance, phase change, thermal interface material
- » “Keep-Out” Requirements: An “Un-Populated” boarder zone of 5 mm around the component is necessary to facilitate the Installation/ Removal of the maxiGRIP™. Please refer to the maxiGRIP™ Keep-Out Guidelines and maxiGRIP™ Installation/Removal Instructions for further details

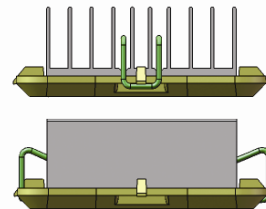
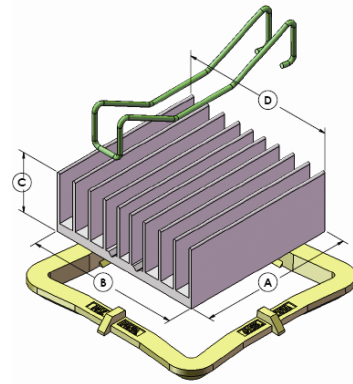

*\*Image above is for illustration purposes only.*

## Thermal Performance

AIR VELOCITY		THERMAL RESISTANCE	
FT/MIN	M/S	°C/W (UNDUCTED FLOW)	°C/W (DUCTED FLOW)
200	1.0	10.3	4.8
300	1.5	7.6	
400	2.0	6.4	
500	2.5	5.7	
600	3.0	5.2	
700	3.5	4.8	
800	4.0	4.5	

## Product Details

DIMENSION A	DIMENSION B	DIMENSION C	DIMENSION D	INTERFACE MATERIAL	FINISH
35 mm	35 mm	7.5 mm	35 mm	CHOMERICS T766	BLUE ANODIZED

### NOTES:

- 1) DIMENSIONS ARE MEASURED IN MILLIMETERS
- 2) DIMENSIONS A & B REFER TO COMPONENT SIZE
- 3) DIMENSION C = THE HEIGHT OF THE HEAT SINK SHOWN ABOVE AND DOES NOT INCLUDE THE HEIGHT OF THE ATTACHMENT METHOD
- 4) ATS RESERVES THE RIGHT TO UPDATE OR CHANGE IT PRODUCTS WITHOUT NOTICE
- 5) CONTACT ATS TO LEARN ABOUT CUSTOM OPTIONS AVAILABLE



**ATS** ADVANCED THERMAL SOLUTIONS, INC.  
Innovations in Thermal Management®

**For more information, to find a distributor or to place an order, visit [www.qats.com](http://www.qats.com) or call: 781.769.2800 (North America); +31 (0) 3569 84715 (Europe).**



# maxiGRIP™ Clearance Guidelines

## Required Board Keep Out Region for maxiGRIP Heat Sink Attachment Hardware

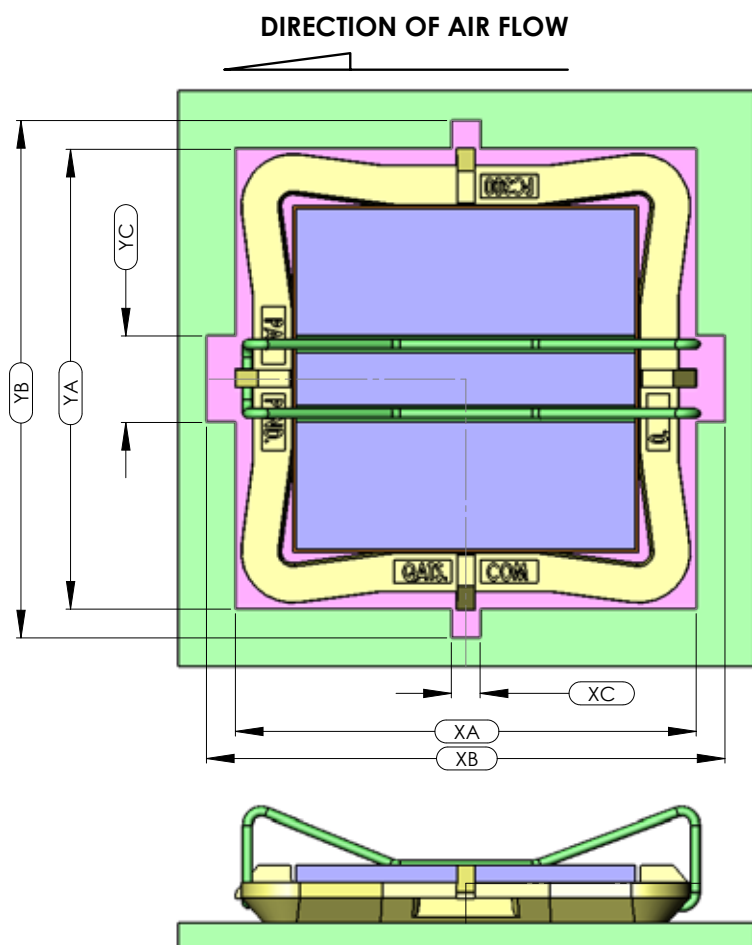

NOM SIZE	XA	XB	XC	YA	YB	YC
17 x 17	23.0	31.0	NA	23.0	23.0	11.0
19 x 19	27.0	31.0	2.5	27.0	31.0	8.0
21 x 21	29.0	33.0	2.5	29.0	33.0	8.0
23 x 23	32.5	36.5	2.5	32.5	36.5	8.0
25 x 25	34.0	38.0	2.5	34.0	38.0	8.0
27 x 27	36.0	40.0	2.5	36.0	40.0	8.0
29 x 29	38.5	42.5	2.5	38.5	42.5	8.0
30 x 30	40.0	44.0	2.5	40.0	44.0	8.0
31 x 31	41.0	45.0	2.5	41.0	45.0	8.0
32.5 x 32.5	43.0	47.0	2.5	43.0	47.0	8.0
33 x 33	43.5	47.5	2.5	43.5	47.5	8.0
35 x 35	45.5	49.5	2.5	45.5	49.5	8.0
37.5 x 37.5	48.5	52.5	2.5	48.5	52.5	8.0
40 x 40	52.0	56.0	2.5	52.0	56.0	8.0
42.5 x 42.5	54.5	58.5	2.5	54.5	58.5	8.0
45 x 45	57.0	61.0	2.5	57.0	61.0	8.0

### NOTES:

1. Additional constraints may apply if / when heat sinks are used with length or width dimensions that exceed the XA and YA dimensions shown in the table. Please contact ATS for assistance with such applications.
2. Data provided for reference only and may vary by application.
3. ATS reserves the right to update or change its products without notice to improve the design or performance.
4. Contact ATS to learn about custom options available.



**ATS** ADVANCED  
THERMAL  
SOLUTIONS, INC.  
Innovations in Thermal Management®

For more information, to find a distributor or to place an order, visit [www.qats.com](http://www.qats.com) or call: 781.769.2800 (North America); +31 (0) 3569 84715 (Europe).



# High Performance BGA Cooling Solutions w/ superGRIP™ Attachment

**ATS PART # ATS-X50350B-C1-R0**

## Features & Benefits

- » Designed for 35 x 35 mm BGA components
- » Requires minimal space around the component's perimeter; ideal for densely populated PCBs
- » Allows the heat sink to be detached and reattached without damaging the component or the PCB, an important feature in the event a PCB may need to be reworked
- » Strong, uniform attachment force helps achieve maximum performance from phase-changing TIMs
- » Eliminates the need to drill mounting holes in the PCB
- » Assembly comes standard with a high performance maxiFLOW™ heat sink which maximizes convection (air) cooling
- » Comes standard with clean break, reworkable, Chomerics T-766 phase change material

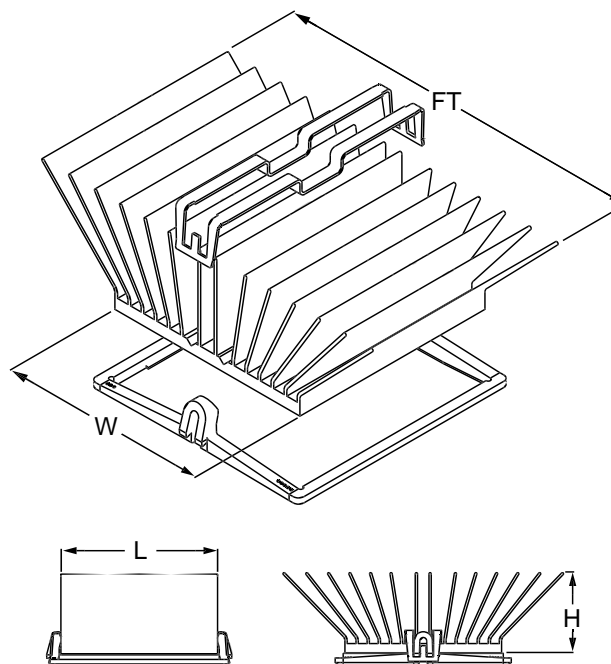

*\*Image above is for illustration purposes only.*

## Thermal Performance

AIR VELOCITY		THERMAL RESISTANCE	
FT/MIN	M/S	°C/W (UNDUCTED FLOW)	°C/W (DUCTED FLOW)
200	1.0	5.3	3.4
300	1.5	3.9	
400	2.0	3.2	
500	2.5	2.9	
600	3.0	2.6	
700	3.5	2.4	
800	4.0	2.2	

## Product Details

LENGTH	WIDTH	HEIGHT	FIN TIP to FIN TIP	INTERFACE MATERIAL	FINISH
35 mm	35 mm	7.5 mm	44.9 mm	CHOMERICS T766	BLUE-ANODIZED

### NOTES:

- 1) Length and width dimensions refer to the size of the component. Dimensions of the heat sink are subject to tolerances of up to .99 mm in order to accommodate the clip assembly
- 2) Thermal performance data are provided for reference only. Actual performance may vary by application
- 3) ATS reserves the right to update or change its products without notice to improve the design or performance
- 4) Additional tooling fees may be required
- 5) Typical lead time is a minimum of 4-6 weeks
- 6) Contact ATS to learn about custom options available



**ATS** ADVANCED THERMAL SOLUTIONS, INC.  
Innovations in Thermal Management®

**For more information, to find a distributor or to place an order, visit [www.qats.com](http://www.qats.com) or call: 781.769.2800 (North America); +31 (0) 3569 84715 (Europe).**



# High Performance BGA Cooling Solutions with superGRIP™ Attachment

**ATS PART # ATS-X53350B-C1-R0**

## Features & Benefits

- » Designed for 35 x 35 mm BGA components
- » superGRIP™ super strong, uniform attachment force helps achieve maximum performance from phase-changing TIM and does not require holes in the PCB
- » Allows the heat sink to be detached and reattached without damaging the component and/or the PCB, an important feature in the event a PCB may need to be reworked
- » Meets Telcordia GR-63-Core Office Vibration, ETSI 300 019 Transportation Vibration, and MIL-STD-810 Shock Testing and Unpackaged Drop Testing standards
- » Requires minimal space around the component's perimeter; ideal for densely populated PCBs
- » "Keep-Out" Requirements: An "Un-Populated" boarder zone of 3 mm around the component is necessary to facilitate the Installation/Removal of the superGRIP™. Please refer to the superGRIP™ Keep-Out Guidelines and superGRIP™ Installation/Removal Instructions for further details

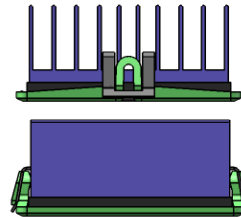
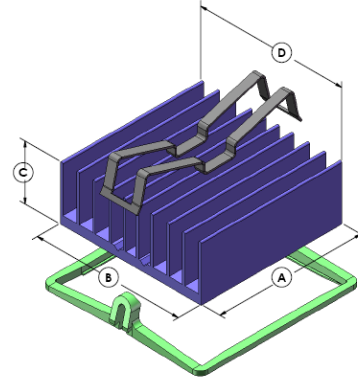

*\*Image above is for illustration purposes only.*

## Thermal Performance

AIR VELOCITY		THERMAL RESISTANCE	
FT/MIN	M/S	°C/W (UNDUCTED FLOW)	°C/W (DUCTED FLOW)
200	1.0	10.3	4.8
300	1.5	7.6	
400	2.0	6.4	
500	2.5	5.7	
600	3.0	5.2	
700	3.5	4.8	
800	4.0	4.5	

## Product Details

DIMENSION A	DIMENSION B	DIMENSION C	DIMENSION D	INTERFACE MATERIAL	FINISH
35 mm	35 mm	7.5 mm	35 mm	CHOMERICS T-766	BLUE ANODIZED

### NOTES:

- 1) DIMENSIONS ARE MEASURED IN MILLIMETERS
- 2) DIMENSIONS A & B REFER TO COMPONENT SIZE
- 3) DIMENSION C = THE HEIGHT OF THE HEAT SINK SHOWN ABOVE AND DOES NOT INCLUDE THE HEIGHT OF THE ATTACHMENT METHOD
- 4) ATS RESERVES THE RIGHT TO UPDATE OR CHANGE IT PRODUCTS WITHOUT NOTICE
- 5) CONTACT ATS TO LEARN ABOUT CUSTOM OPTIONS AVAILABLE



**ATS** ADVANCED THERMAL SOLUTIONS, INC.  
Innovations in Thermal Management®

**For more information, to find a distributor or to place an order, visit [www.qats.com](http://www.qats.com) or call: 781.769.2800 (North America); +31 (0) 3569 84715 (Europe).**



# superGRIP™ Clearance Guidelines

## Required Board Keep Out Region for superGRIP Heat Sink Attachment Hardware

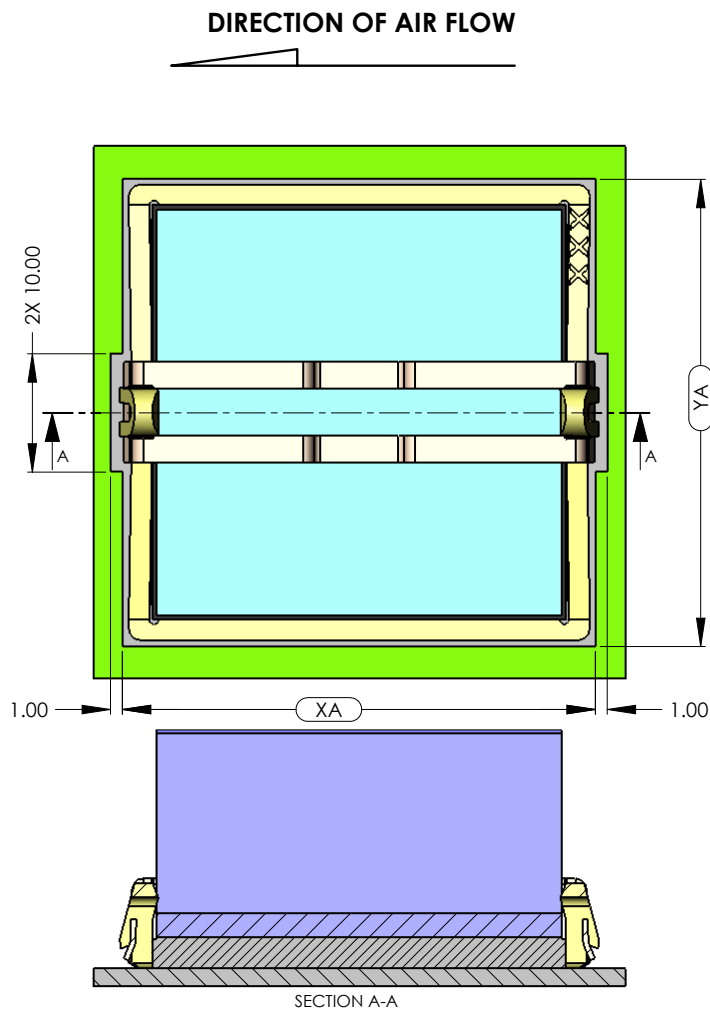

NOM SIZE (mm)	XA (mm)	YA (mm)
15 x 15	18.5	18
17 x 17	20.6	20.1
19 x 19	22.7	22.2
21 x 21	24.9	24.4
23 x 23	27.1	26.6
25 x 25	29.3	28.8
27 x 27	31.5	31
29 x 29	33.6	33.1
30 x 30	34.7	34.2
31 x 31	35.8	35.3
32.5 x 32.5	37.4	36.9
33 x 33	37.9	37.4
35 x 35	40	39.5
37.5 x 37.5	42.7	42.2
40 x 40	45.4	44.9
42.5 x 42.5	48	47.5
45 x 45	50.7	50.2

### NOTES:

1. Additional constraints may apply if / when heat sinks are used with length or width dimensions that exceed the XA and YA dimensions shown in the table. Please contact ATS for assistance with such applications.
2. Data provided for reference only and may vary by application.
3. ATS reserves the right to update or change its products without notice to improve the design or performance.
4. Contact ATS to learn about custom options available.



**ATS** ADVANCED THERMAL SOLUTIONS, INC.  
Innovations in Thermal Management®

For more information, to find a distributor or to place an order, visit [www.qats.com](http://www.qats.com) or call: 781.769.2800 (North America); +31 (0) 3569 84715 (Europe).



# High Performance BGA Cooling Solutions w/ Thermal Tape Attachment

**ATS PART # ATS-54350D-C2-R0**

## Features & Benefits

- » High aspect ratio, straight fin heat sinks that are ideal for compact PCB environments
- » Designed specifically for BGAs and other surface mount packages
- » Comes preassembled with high performance thermal interface material

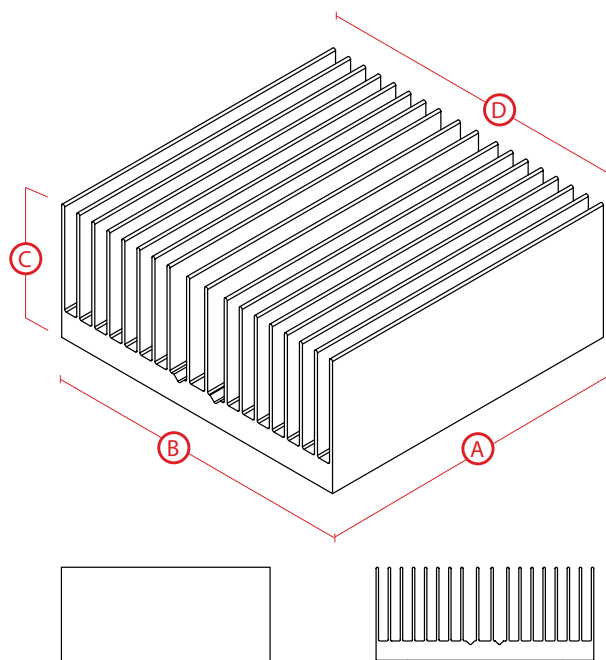

*\*Image above is for illustration purposes only.*

## Thermal Performance

AIR VELOCITY		THERMAL RESISTANCE	
FT/MIN	M/S	°C/W (UNDUCTED FLOW)	°C/W (DUCTED FLOW)
200	1.0	10.3	4.8
300	1.5	7.6	
400	2.0	6.4	
500	2.5	5.7	
600	3.0	5.2	
700	3.5	4.8	
800	4.0	4.5	

## Product Details

DIMENSION A	DIMENSION B	DIMENSION C	DIMENSION D	INTERFACE MATERIAL	FINISH
35 mm	35 mm	9.5 mm	35 mm	SAINT-GOBAIN C675	BLACK-ANODIZED

### NOTES:

- 1) Dimension C = heat sink height from bottom of the base to the top of the fin field.
- 2) Thermal performance data are provided for reference only. Actual performance may vary by application.
- 3) ATS reserves the right to update or change its products without notice to improve the design or performance.
- 4) Contact ATS to learn about custom options available.



**ATS** ADVANCED  
THERMAL  
SOLUTIONS, INC.  
Innovations in Thermal Management®

**For more information, to find a distributor or to place an order, visit [www.qats.com](http://www.qats.com) or call: 781.769.2800 (North America); +31 (0) 3569 84715 (Europe).**

# Star LED Heat Sink



**ATS PART # ATSEU-077D-C1-R0**

## Features & Benefits

- » Designed for high-performance convection cooling of high heat flux LEDs
- » Base includes inner threads for attachment of brackets and other hardware
- » Each Star series heat sink is made from lightweight, anodized aluminum for maximum thermal performance

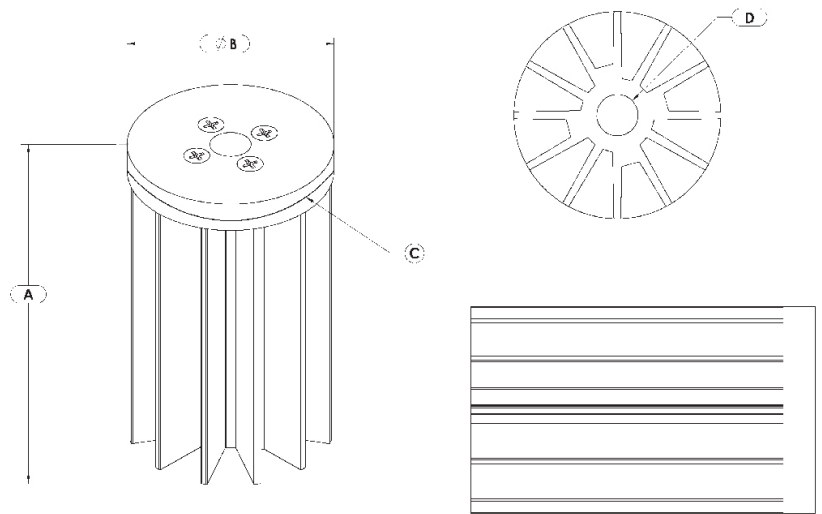

FOR ILLUSTRATION PURPOSES ONLY

## Thermal Performance

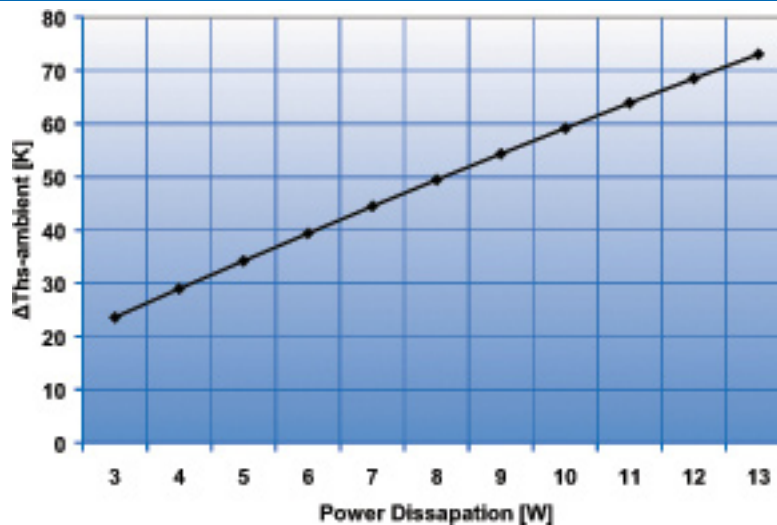

## Product Details

LENGTH (A)	DIAMETER (B)	OUTER THREAD (C)	INNER THREAD (D)	WEIGHT	FINISH
45 mm	45 mm	NONE	M10X1	74 G	BLACK

### NOTES:

- 1) Thermal Performance data are provided for reference only- Actual performance may vary by application
- 2) ATS reserves the right to update or change its products without notice
- 3) Contact ATS to learn about custom options available



**ATS** ADVANCED THERMAL SOLUTIONS, INC.  
Innovations in Thermal Management®

**For more information, to find a distributor or to place an order, visit [www.Qats.com](http://www.Qats.com) or call: 781.769.2800 (North America); +31 (0) 3569 84715 (Europe).**



# ATS Extrusion Profiles

**ATS PART # ATS470105044-EXL10-R0**

## Features & Benefits

- » Aluminum extrusions are the most cost-effective solution for the majority of electronic cooling applications
- » This extrusion profile has 10 fins
- » Extrusion type is straight fin, AL-6063
- » Surface area (in<sup>2</sup>/in) is 36.80

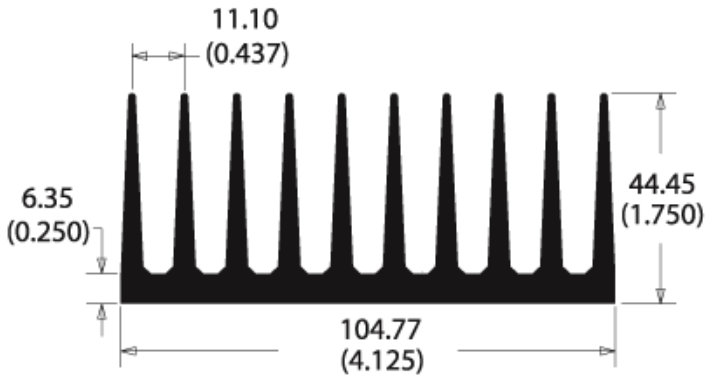

*\*Image above is for illustration purposes only.*

## Thermal Performance

### HEAT SINK THERMAL RESISTANCE

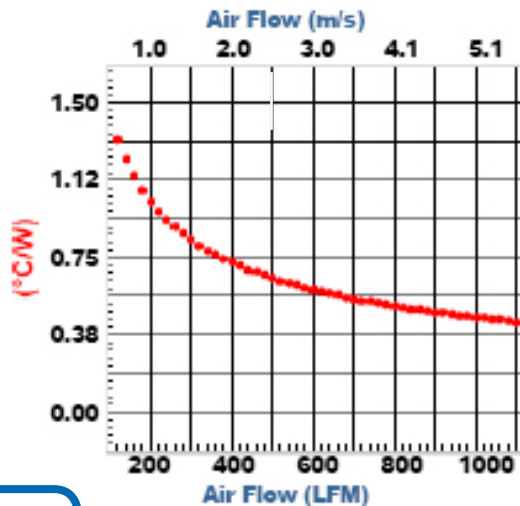

## Product Details

LENGTH	WIDTH	HEIGHT	FIN SPACING	BASE THICKNESS	FINISH
470 mm	104.77 mm	44.45 mm	11.10 mm	6.35 mm	NONE

### NOTES:

- 1) Thermal curve based on 76 mm length.
- 2) Thermal performance data are provided for reference only. Actual performance may vary by application.
- 3) ATS reserves the right to update or change its products without notice to improve the design or performance.
- 4) Contact ATS to learn about custom options available.



**ATS** ADVANCED  
THERMAL  
SOLUTIONS, INC.  
Innovations in Thermal Management®

**For more information, to find a distributor or to place an order, visit [www.Qats.com](http://www.Qats.com) or call: 781.769.2800 (North America); +31 (0) 3569 84715 (Europe).**



# maxiFLOW™ Cross Cut High Performance Heat Sinks with Plastic Push Pin



**ATS PART # ATS-1038-C1-R0**

## Features & Benefits

- » For larger heat sinks and higher pre-loads, push pins with compression springs are an effective mounting choice. The push pin has a flexible barb at the end that is designed to engage with a pre-drilled hole in a PWB. The compression spring adds the necessary force to hold the assembly together. Provides better thermal performance than comparable size straight fin and pin fin heat sinks
- » Features proven high performance maxiFLOW™ heat sink spread fin array to maximize cooling surfaces
- » Ideal for tight spaced components where wider heat sinks can't be used
- » Provided with pre-assembled thermal interface material centered on base
- » Nylon push pin with steel compression spring
- » Recommended through hole size in PCB is 3.00 mm

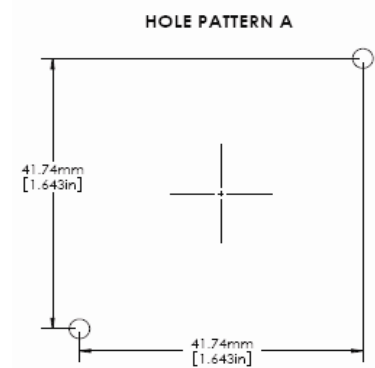
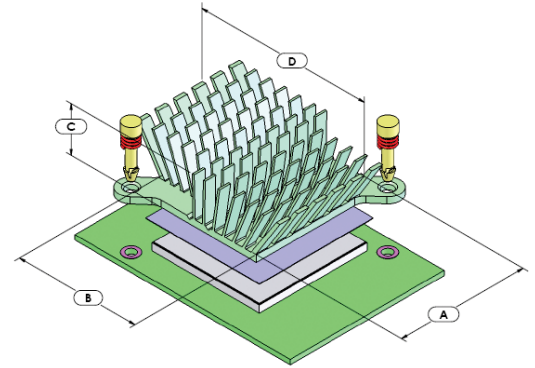

\*Image above is for illustration purposes only.

## Thermal Performance

AIR VELOCITY		THERMAL RESISTANCE (°C/W UNDUCTED)	
FT/MIN	M/S	AIR FLOW STRAIGHT	AIR FLOW SIDEWAYS
200	1.0	5	6.2
300	1.5	3.9	4.9
400	2.0	3.3	3.9
500	2.5	2.8	3.3
600	3.0	2.5	3

## Product Details

DIMENSION A	DIMENSION B	DIMENSION C	DIMENSION D	INTERFACE MATERIAL	FINISH
40 mm	38 mm	10 mm	47 mm	CHOMERICS T-766	GREEN ANODIZED

### NOTES:

- 1) DIMENSION C = HEAT SINK HEIGHT FROM BOTTOM OF THE BASE TO THE TOP OF THE FIN FIELD
- 2) THERMAL PERFORMANCE DATA ARE PROVIDED FOR REFERENCE ONLY. ACTUAL PERFORMANCE MAY VARY BY APPLICATION.
- 3) ATS RESERVES THE RIGHT TO UPDATE OR CHANGE ITS PRODUCTS WITHOUT NOTICE
- 4) CONTACT ATS TO LEARN ABOUT CUSTOM OPTIONS AVAILABLE



**ATS** ADVANCED THERMAL SOLUTIONS, INC.  
Innovations in Thermal Management®

**For more information, to find a distributor or to place an order, visit [www.qats.com](http://www.qats.com) or call: 781.769.2800 (North America); +31 (0) 3569 84715 (Europe).**

# maxiFLOW™ Cross Cut High Performance Heat Sinks with Metal Push Pin



**ATS PART # ATS-1038-C2-R0**

## Features & Benefits

- » For larger heat sinks and higher pre-loads, push pins with compression springs are an effective mounting choice. The push pin has a flexible barb at the end that is designed to engage with a pre-drilled hole in a PWB. The compression spring adds the necessary force to hold the assembly together. Provides better thermal performance than comparable size straight fin and pin fin heat sinks
- » Features proven high performance maxiFLOW™ heat sink spread fin array to maximize cooling surfaces
- » Ideal for tight spaced components where wider heat sinks can't be used
- » Provided with pre-assembled thermal interface material centered on base
- » Brass push pin with steel compression spring
- » Recommended through hole size in PCB is 3.00 mm

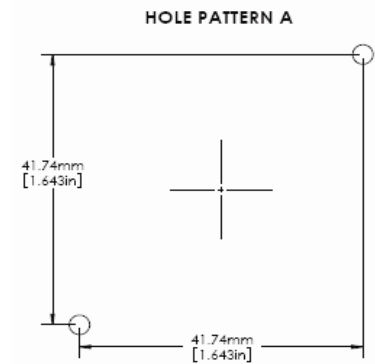
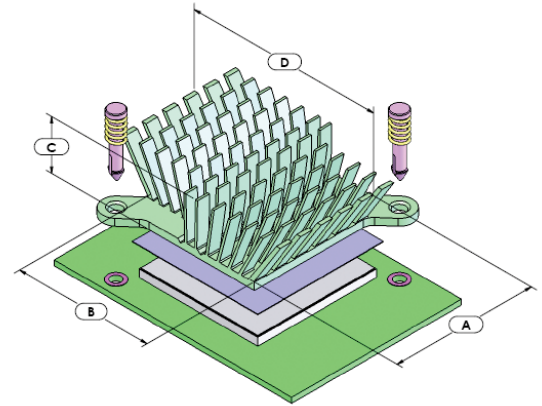

\*Image above is for illustration purposes only.

## Thermal Performance

AIR VELOCITY		THERMAL RESISTANCE (°C/W UNDUCTED)	
FT/MIN	M/S	AIR FLOW STRAIGHT	AIR FLOW SIDEWAYS
200	1.0	5	6.2
300	1.5	3.9	4.9
400	2.0	3.3	3.9
500	2.5	2.8	3.3
600	3.0	2.5	3

## Product Details

DIMENSION A	DIMENSION B	DIMENSION C	DIMENSION D	INTERFACE MATERIAL	FINISH
40 mm	38 mm	10 mm	47 mm	CHOMERICS T-766	GREEN ANODIZED

### NOTES:

- 1) DIMENSION C = HEAT SINK HEIGHT FROM BOTTOM OF THE BASE TO THE TOP OF THE FIN FIELD.
- 2) THERMAL PERFORMANCE DATA ARE PROVIDED FOR REFERENCE ONLY. ACTUAL PERFORMANCE MAY VARY BY APPLICATION.
- 3) ATS RESERVES THE RIGHT TO UPDATE OR CHANGE ITS PRODUCTS WITHOUT NOTICE
- 4) CONTACT ATS TO LEARN ABOUT CUSTOM OPTIONS AVAILABLE



**ATS** ADVANCED THERMAL SOLUTIONS, INC.  
Innovations in Thermal Management®

**For more information, to find a distributor or to place an order, visit [www.qats.com](http://www.qats.com) or call: 781.769.2800 (North America); +31 (0) 3569 84715 (Europe).**

# maxiFLOW™ Cross Cut High Performance Heat Sinks with Hardware Attachment



**ATS PART # ATS-1038-C3-R0**

## Features & Benefits

- » For larger heat sinks and higher pre-loads, push pins with compression springs are an effective mounting choice. The push pin has a flexible barb at the end that is designed to engage with a pre-drilled hole in a PWB. The compression spring adds the necessary force to hold the assembly together. Provides better thermal performance than comparable size straight fin and pin fin heat sinks
- » Features proven high performance maxiFLOW™ heat sink spread fin array to maximize cooling surfaces
- » Ideal for tight spaced components where wider heat sinks can't be used
- » Provided with pre-assembled thermal interface material centered on base
- » PEM Standoff with compression and screws
- » Recommended through hole size in PCB is 3.00 mm

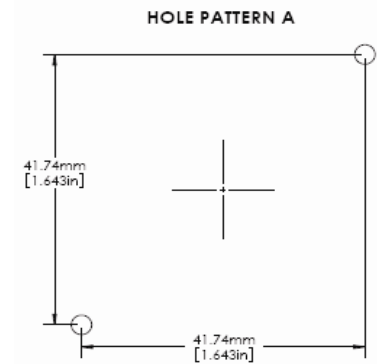
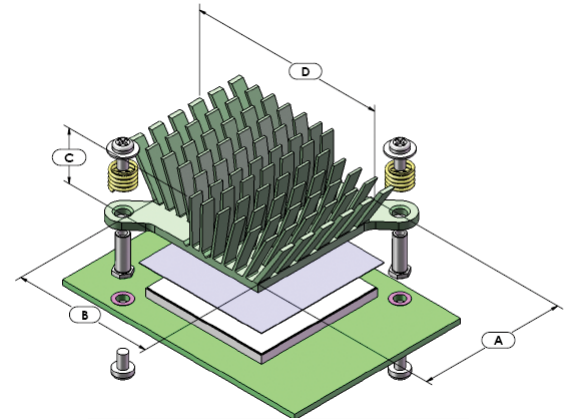

*\*Image above is for illustration purposes only.*

## Thermal Performance

AIR VELOCITY		THERMAL RESISTANCE (°C/W UNDUCTED)	
FT/MIN	M/S	AIR FLOW STRAIGHT	AIR FLOW SIDEWAYS
200	1.0	5	6.2
300	1.5	3.9	4.9
400	2.0	3.3	3.9
500	2.5	2.8	3.3
600	3.0	2.5	3

## Product Details

DIMENSION A	DIMENSION B	DIMENSION C	DIMENSION D	INTERFACE MATERIAL	FINISH
40 mm	38 mm	10 mm	47 mm	CHOMERICS T-766	GREEN ANODIZED

### NOTES:

- 1) DIMENSION C = HEAT SINK HEIGHT FROM BOTTOM OF THE BASE TO THE TOP OF THE FIN FIELD.
- 2) THERMAL PERFORMANCE DATA ARE PROVIDED FOR REFERENCE ONLY. ACTUAL PERFORMANCE MAY VARY BY APPLICATION.
- 3) ATS RESERVES THE RIGHT TO UPDATE OR CHANGE ITS PRODUCTS WITHOUT NOTICE
- 4) CONTACT ATS TO LEARN ABOUT CUSTOM OPTIONS AVAILABLE



**ATS** ADVANCED THERMAL SOLUTIONS, INC.  
Innovations in Thermal Management®

**For more information, to find a distributor or to place an order, visit [www.qats.com](http://www.qats.com) or call: 781.769.2800 (North America); +31 (0) 3569 84715 (Europe).**

# ATS fanSINK™ with maxiGRIP™ Attachment



**ATS PART # ATS-61270D-C1-R0**

## Features & Benefits

- » X-Cut Straight Fin Heat Sink Fins offer omni-directional air flow for optimum thermal performance independent of PCB lay-out
- » Stainless Steel Screw Fan Attachment - Ensures dependable long-term fan to heat sink assembly
- » Component Attachment - ATS maxiGRIP™ is a proven high reliability mechanical attachment system
- » ATS maxiGRIP™ Hardware includes a High Performance Plastic “Frame Clip” and 300 Series Stainless Steel “Spring Clip”- avoiding PCB through holes
- » Provided with pre-assembled Thermal Interface Material (TIM) centered on base
- » “Keep-Out” Requirements: An “Un-Populated” boarder zone of 5 mm around the component is necessary to facilitate the Installation/Removal of the maxiGRIP™. Please refer to the maxiGRIP™ Keep-Out Guidelines and maxiGRIP™ Installation/Removal Instructions for further details
- » **Please Note: FAN NOT INCLUDED. Fan type is specific to individual customer requirements. Fans need to be independently sourced.**

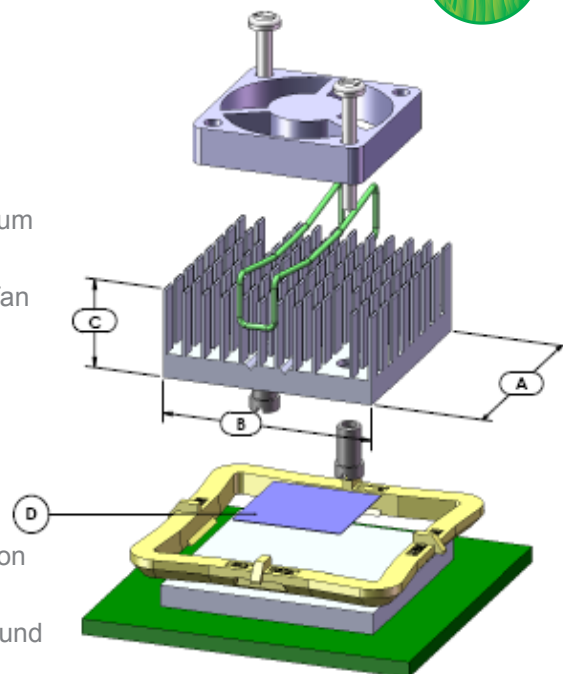
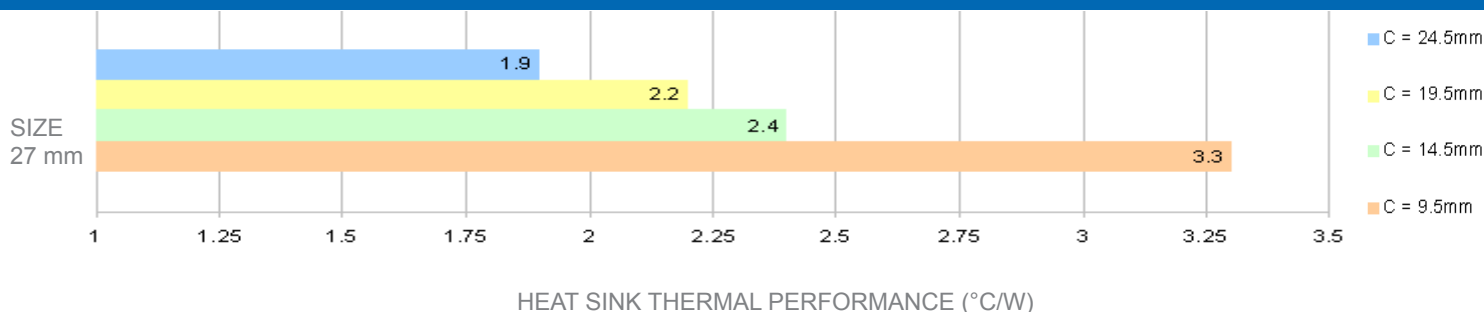

ILLUSTRATION ONLY  
**FAN NOT INCLUDED**

## Thermal Performance

### ATS fanSINK™ HEIGHT COMPARISON

HS HEIGHT



## Product Details

DIMENSION A	DIMENSION B	DIMENSION C	DIMENSION D	INTERFACE MATERIAL	FINISH
27 mm	27 mm	9.5 mm	15 X 15 mm	CHOMERICS T-412	BLACK ANODIZED

### NOTES:

- 1) Dimension C = heat sink height from bottom of the base to the top of the fin field
- 2) Thermal data reference only. Actual performance may vary by application
- 3) ATS reserves the right to update or change its products without notice
- 4) Contact ATS to learn about custom options available
- 5) Standard Fan Dimensions L x W x H are: 25 mm x 25 mm x 6 mm
- 6) Standard Fan Hole Pattern is: 20mm C-C, (center-to-center)



**ATS** ADVANCED  
THERMAL  
SOLUTIONS, INC.  
Innovations in Thermal Management®

**For more information, to find a distributor or to place an order, visit [www.Qats.com](http://www.Qats.com) or call: 781.769.2800 (North America); +31 (0) 3569 84715 (Europe).**

# Thermal Consulting Services

The True Complete Solutions Provider

## Service

ATS will **Evaluate, Analyze & Design a Solution** to your electronics cooling problems.

## Goal

ATS seeks to provide the most innovative and cost effective solutions for your thermal problems.

## Process

ATS will address your problem with detailed thermal analysis and experimentation. We can examine the entire packaging domain that includes component, circuit boards (PCBs), shelf (rack) and the complete system.

## Facility

### Computational Laboratory

Analytical and computational modeling (supported by Flotherm & CFDdesign thermal analysis software packages and ANSYS for thermal and mechanical studies).

### Thermal/Fluids Laboratory

A state-of-the-art facility for experimental characterization of components, boards, and systems.

## The ATS Difference

### Providing Solutions

ATS prides itself on being the true complete solutions' provider. We provide analysis, design recommendation, and deliver the hardware solution, e.g., custom design maxiFLOW™ heat sinks that are suited for your application(s).

### Customized Solutions

At Advanced Thermal Solutions, we believe customers who wish to remain competitive should consider a design-to-suit opportunity strategy first. Contrary to common perception, this usually proves to be less expensive to the customer in the long run, because of the ensuing gain in product efficiency and compatibility.

### Engineering-Driven

ATS is a thermal management company—the firm has several staff and consulting engineers with doctorates in the thermal sciences and over 100 years of collective experience. We deliver engineered solutions rich in innovation and least in cost.

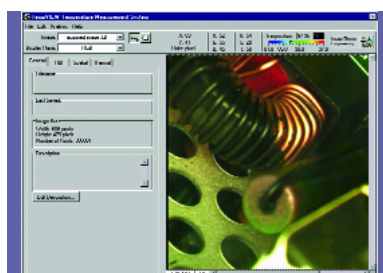
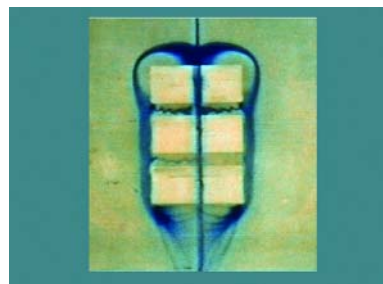
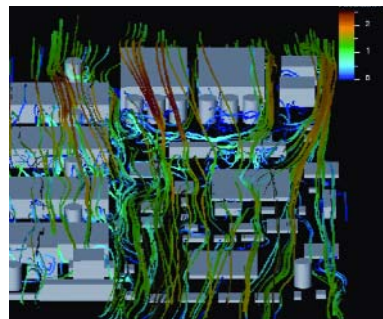
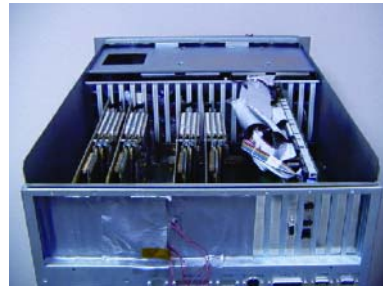

Innovation in Thermal Management™

- **Flow Simulation**  
High and low speed wind tunnels for component, heat sink and PCB level characterization at different operating ambient.
- **Thermography (Die Level)** Liquid Crystal Imaging system for temperature measurement and mapping of ICs and components. The measurement resolutions span from small scale (1 micron) to large PCBs.
- **Thermography (PCB and System)** IR thermography system for board and system thermal mapping.
- **Velocity Measurement**  
Hot wire anemometry for mapping velocity and temperature distributions in PCBs and systems.
- **Contact Resistance**  
Measurement capability
- **Thermal Conductivity** Material thermal conductivity measurement facility.
- **Heat Transfer Coefficient** Measurement facility.
- **Liquid Cooling Facility**  
For thermal characterization of heat sinks and boards, 3kW cooling capacity.
- **Elevated Temperature** Testing Facility for components and boards.
- **Sensor Calibration Services**  
For temperature, velocity, pressure and heat flux sensors.
- **Fan Characterization Facility** Pressure drop versus volumetric flow rate measure-

**Advanced Thermal Solutions, Inc.**

89-27 Access Road, Norwood, MA 02062 USA

Tel: 781-769-2800 / Fax: 781-769-9979 / Email: ats@qats.com / www.qats.com

© All Rights Reserved



# iQ-200™

## MEASURE TEMPERATURE, VELOCITY & PRESSURE WITH ONE SYSTEM

- » **iQ-200™** provides the user with the capability to **simultaneously** or **individually** measure all of the required thermal parameters with one system.
- » **iQ-200™** provides multiple channels of Temperature, Velocity and Pressure.
- » **iQ-200™** eliminates the need for having multiple systems or additional software to synchronize data collection of different parameters.
- » **iQ-200™** comes with the unique *LabVIEW™* - based operating software, **IQstage™**, eliminates data collection errors induced because of measurement time lapses or transience associated with the use of multiple systems.
- » **iQ-200™** provides a compact, portable and versatile system to minimize lab clutter and go where measurement is required.



### APPLICATION DOMAIN

**iQ-200™** is designed to be used wherever Temperature, Pressure and Velocity measurements are required, either simultaneously or individually.

*Some examples where iQ-200™ is used:*

- » Heat sink design and selection
- » PCB characterization
- » Card rack (ATCA, PICMG, 1U, etc.) characterization
- » Qualification testing in the environmental chamber, e.g., NEBS, Milspec, etc.
- » Mockup testing
- » Wind tunnel testing of cards, heatsinks, etc.

#### Data Port Panel



#### Back Panel



#### OVERALL DIMENSIONS (D x W x H)

43 cm x 34 cm x 12.6 cm  
(17" x 13.3" x 5")

#### NUMBER OF VELOCITY CHANNELS

16

#### FLOW RANGE

0 to 50 m/s (0 to 10,000 ft/min)

#### NUMBER OF THERMOCOUPLES

12 (J, K, T, and E types)

#### NUMBER OF PRESSURE SENSORS

4 (Differential)

#### PRESSURE RANGE

0 to 0.15 psi

#### SOFTWARE

**IQstage™**

#### VOLTAGE INPUT

110V or 220V

#### WEIGHT

7.5 kg (15 lbs.)

### TEMPERATURE

- » 12 thermocouple ports supporting J, K, T and E types, with a range of -40 to 750°C.
- » 16 thermister ports (also used for velocity measurement) with a range of -10 to 85°C.

### VELOCITY

- » 16 hot wire anemometer ports supporting ATS single sensor velocity measurement technology, (requiring no need to change sensors when measuring different velocity ranges).
- » Supports ATS unique, patented Candle Stick Sensor

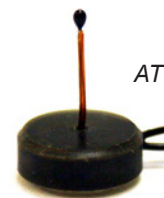

ATS Candle-Stick  
Sensor

- » Standard range for velocity measurement is 0-6 m/s (1200 ft/min). With custom calibration, the range is 0-50 m/s (10,000 ft/min) – no need to change sensors

### PRESSURE

- » Four ports supporting differential or absolute pressure measurements with a range of 0-1,035Pa (0-0.15 psi)

### DATA ACQUISITION

#### SOFTWARE - IQstage™

- » **IQstage™** manages incoming data from various sensors and provides a rich graphical presentation of the results
- » User-friendly *LabVIEW™* - based **IQstage™** is included with the system

For further technical information, please contact Advanced Thermal Solutions, Inc. at **1-781-769-2800** or **www.qats.com**



Innovation in Thermal Management™

### ATVS-NxT™ Features

- **ATVS-NxT™** handles up to 32 sensors for simultaneous single point measurement of air velocity & temperature.\*
- **ATVS-NxT™** measures air temperature, velocity and surface temperatures.
- **ATVS-NxT™** allows for the sensors to be used in any channel.
- **ATVS-NxT™** is the only system available today that can measure both temperature and air velocity with a single sensor.
- **ATVS-NxT™** sensors are calibrated for both low (natural convection) and high velocity flows.
- The data measured by **ATVS-NxT™** can be automatically averaged for quick results.
- **ATVS-NxT™** does not require a PC to operate.
- **ATVS-NxT™** uses the same sensor to measure the full range of flow (0 to 10,000 ft/min).
- **ATVS-NxT™** offers research quality results with the ease of use of hand-held meters.
- **ATVS-NxT™** uses *stageVIEW-NxT™* for data acquisition and reporting applications.
- **ATVS-NxT™** has an internal 8 GB hard drive.
- **ATVS-NxT™** has ethernet capability.
- **ATVS-NxT™** has a RW CD.
- **ATVS-NxT™** can be used either as a Touch Panel or with a mouse and keyboard.
- **ATVS-NxT™** enables velocity & temperature measurement on the LAN or WWW anywhere in the world.

\*Using Microbead element

# ATVS-NxT™

## Thermal Measurement on the LAN or WWW - Fully Portable Automatic Velocity & Temperature Scanner.

The ATVS-NxT™ is a portable system that can handle a variety of velocity & temperature measurements. The system has an embedded PC for its operation and uses the *stageVIEW-NxT™* software for data acquisition and reporting. It is capable of being used as a Touch Panel or with a mouse and keyboard. The system has an internal 8 GB hard drive for data storage, a RW CD-Rom and *ethernet* capabilities. The ethernet connection enables users to network **ATVS-NxT™** on their LAN or use it remotely anywhere in the world.

The **ATVS-NxT™** is a fully portable Touch Panel patented multi-channel Hot Wire Anemometer system designed for measuring air velocity and temperature in any environment and in applications where single- or multi-point measurements are required. The unique and

patented sensors are designed to be flexible, robust and low profile to minimize flow disturbance. They can be easily placed anywhere in the test domain. The use of a single sensor to measure both temperature and velocity eliminates errors introduced as a result of the flow being non-isothermal.



The **ATVS-NxT™** is a scientific instrument and great care is taken in the calibration process of each sensor. The system can accommodate up to 32 channels (sensors) for easy and accurate mapping of the velocity and temperature fields of the test domain.

### Technical Data

- **Temperature Range** -30°C to 150°C ±1°C at temperature
- **Velocity Range** 0 to 51 m/s (10,000 ft/min) ± 2% at velocity
- **Measurement duration** Unlimited (8 GB if data stored)
- **Depth** 15.0" (38cm)
- **Width** 19" (48cm)
- **Height** 7.5" (19cm)
- **Weight** 15 lbs (7.5 kg)
- **stageVIEW-NxT™** software has a thermal analysis module for quick evaluation of component temperature
- **No need for an external PC**
- **Requires 110V or 220V (international) power**
- **Sensor Transparent Channel**
- **Fully Automated Data**
- **Acquisition & Reduction**
- **Maximum number of Channels 32**

### Advanced Thermal Solutions, Inc.

89-27 Access Road, Norwood, MA 02062 USA  
Tel: 781-769-2800 / Fax: 781-769-9979 / Email: ats@qats.com / www.qats.com

© All Rights Reserved



Innovation in Thermal Management™

# ATVS-2020™

## Automatic Temperature & Velocity Scanner

### ATVS-2020™ Features

- **ATVS-2020™** handles up to 32 sensors for simultaneous single point measurement of air temperature & velocity.\*
- **ATVS-2020™** measures air temperature, velocity and surface temperatures.
- **ATVS-2020™** allows for the sensors to be used in any channel.
- **ATVS-2020™** is the only system available today that can measure both temperature and air velocity with a single sensor.
- **ATVS-2020™** sensors are calibrated for both low (natural convection) and high velocity flows.
- The data measured by **ATVS-2020™** can be automatically averaged for quick results.
- **ATVS-2020™** requires a PC to operate and is compatible via an RS-232 port.
- **ATVS-2020™** uses the same sensor to measure the full range of flow (0 to 10,000 ft/min).
- **ATVS-2020™** offers research quality results with the ease of use of hand-held meters.
- **ATVS-2020™** uses **stageVIEW™** for data acquisition and reporting applications.

\*Using Microbead element



The ATVS-2020™ is a patented multi-channel Hot Wire Anemometer system designed for measuring air temperature and velocity in applications where single- or multi-point measurements are required. The unique and patented sensors are designed to be flexible, robust and low profile to minimize flow disturbance.

They can be easily placed anywhere in the test domain. The use of a single sensor to measure both temperature and velocity eliminates errors introduced as a result of the flow being non-isothermal.

The ATVS-2020™ is a scientific instrument. Great care is taken in the calibration process of each sensor. The system can accommodate up to 32 channels (sensors) for easy and accurate mapping of the velocity and temperature fields of the test domain.

The ATVS-2020™ is a portable system that can handle a variety of thermal measurement tasks. The system requires a PC for its operation and uses the stageVIEW™ software for data acquisition and reporting.

### stageVIEW™ SOFTWARE



Control Panel

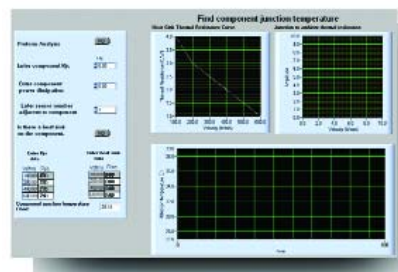

Data Center

### Technical Data

- **Max. No of Channels** 32
- **Temperature Range** -30°C to 150°C ±1°C at temperature
- **Velocity Range** 0 to 51 m/s (10,000 ft/min) ± 2% at velocity
- **Measurement duration** Unlimited (PC storage dependent)
- **Depth** 11.0" (27.9cm)
- **Width** 13.5" (34.3cm)
- **Height** 5.3" (13.5cm)
- **Weight** 10 lbs (5 kg)
- **Computer Interface** RS232 port
- **stageVIEW™ software has a thermal analysis module for quick evaluation of component temperature**
- **Requires 110V VAC or 220V VAC(international) power**
- **Sensor transparent channel**
- **Fully automated data acquisition & reduction**



# eATVS-4 and -8™

## Automatic Temperature & Velocity Scanner

The eATVS-4™ and eATVS-8™ Automatic Temperature and Velocity Scanners are portable, 4- and 8-channel hot wire anemometer systems. Fully automated, these research-quality instruments take accurate single- or multi-point measurements of air temperature, velocity and surface temperature in complex environments, such as PCBs and electronics enclosures. When used as temperature loggers, they can measure both fluid and solid temperatures.

Useable in rackmount or desktop configurations, eATVS-4™ and eATVS-8™ employ patented, fast-response, omni-directional sensors, which measure both temperature and velocity. This patented single-sensor technology eliminates errors introduced as a result of air flow being non-isothermal. Each precisely calibrated sensor is flexible and robust with a low-profile configuration that allows minimally intrusive mounting throughout the peaks and valleys created by the PCB components. These systems require a PC to operate and utilize the stageVIEW™ software for data acquisition and reporting.

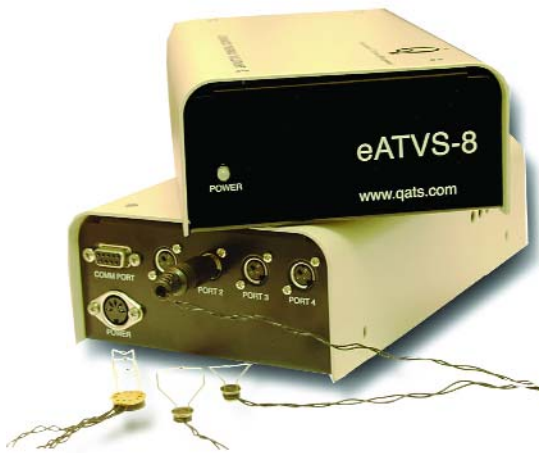

### stageVIEW™ SOFTWARE

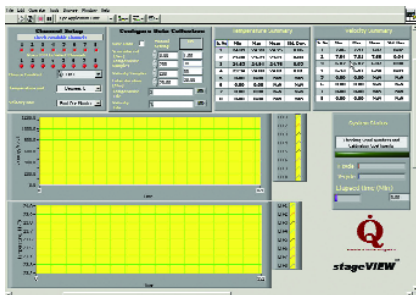

### Technical Data

- **Max. No of Channels** 4 for eATVS-4™ and 8 for eATVS-8™
- **Temperature Range** - 30°C to 150°C ±1°C at temperature
- **Velocity Range** 0 to 50 m/s (10,000 ft/min) ± 2% at velocity
- **Sensors** Up to 8; works with all ATS family of Sensors
- **Measurement duration** Depends upon the PC Storage Limitation in the Save File Mode, Unlimited without Saving Data
- **Depth** 9 1/4" (23.5 cm)
- **Width** 5 1/4" (13.4 cm)
- **Height** 2.5" (6.4 cm)
- **Weight** 4 lbs (2 kg)
- **PC Software** stageVIEW™ with thermal analysis module
- **Computer Interface** RS232 Port



Innovation in Thermal Management™

### eATVS-4™ & eATVS-8™ Features

- **eATVS-4™ & eATVS-8™** handles up to 8 sensors for simultaneous single point measurement of air temperature & velocity.\*
- **eATVS-4™ & eATVS-8™** measures air temperature, velocity and surface temperatures.
- **eATVS-4™ & eATVS-8™** allows for the sensors to be used in any channel.
- **eATVS-4™ & eATVS-8™** is the only system available that can measure both temperature and air velocity with a single sensor.
- **eATVS-4™ & eATVS-8™** sensors are calibrated for both low (natural convection) and high velocity flows.
- The data measured by **eATVS-4™ & eATVS-8™** can be automatically averaged for quick results.
- **eATVS-4™ & eATVS-8™** requires a PC to operate and is compatible via RS-232 port.
- **eATVS-4™ & eATVS-8™** uses the same sensor to measure the full range of flow (0 to 10,000 ft/min).
- **eATVS-4™ & eATVS-8™** offers research quality results with the ease of use of hand-held meters.
- **eATVS-4™ & eATVS-8™** uses stageVIEW™ for data acquisition and reporting applications.

\*Using Microbead element



Innovation in Thermal Management™

# ATVS-2000™

## Automatic Temperature & Velocity Scanner

### ATVS-2000™ Features

- **ATVS-2000™** handles up to 32 sensors for simultaneous single point measurement of temperature & velocity.\*
- **ATVS-2000™** measures air temperature, velocity and surface temperatures.
- **ATVS-2000™** is truly a portable system with internal data storage medium and does NOT require a PC to operate.
- **ATVS-2000™** is the only system available that can measure both air temperature and air velocity with a single sensor.
- **ATVS-2000™** sensors are calibrated for low (natural convection) and high velocity flows.
- The data measured by **ATVS-2000™** is automatically averaged for quick results.
- **ATVS-2000™** is PC compatible via an RS-232 port.
- **ATVS-2000™** is equipped with a monitor port for data viewing.
- **ATVS-2000™** offers research quality results with the ease of use of hand-held meters.
- **ATVS-2000™** is designed for electronics cooling applications.

\*Using Microbead element



The ATVS-2000™ is a multi-channel scanner designed for measuring temperature and velocity in applications where single- or multi-point measurements are required. The unique and patented sensors are designed to be flexible, robust and low profile to minimize flow disturbance. They can be easily placed anywhere in the test domain.

The use of a single sensor to measure both temperature and velocity eliminates errors introduced as a result of flow being non-isothermal.

The ATVS-2000™ is a scientific instrument. Great care is taken in the calibration process of each sensor. The system can accommodate up to 32 channels (sensors) for easy and accurate mapping of the velocity and temperature fields of the test domain.

The ATVS-2000™ is a portable system that can handle a variety of thermal measurement tasks.

### Technical Data

- **Max. No. Of Channels** 32
- **Temperature Range** -30°C to 150°C ±1°C at temperature
- **Velocity Range** 0 to 50 m/s (10,000 ft/min) ± 2% at velocity
- **Measurement duration** Unlimited if not saved
- **Depth** 10" (25.4cm)
- **Width** 10" (25.4cm)
- **Height** 5.5" (14cm)
- **Weight** 7.8 lbs (3.5kg)
- **RS232 connection port** If PC connection is desired
- **Monitor ports** Printer & external (optional)

# Sensors

## ATVS and eATVS Family of Sensors

Temperature and velocity sensors from ATS provide the most accurate reading in Hot Wire Anemometry. Low profile sensors that can be placed anywhere in your system where no other probes can go.



**MS 1000-CS-WC**  
Candlestick Sensor  
Measures temperature and air velocity.  
Thin, low profile shape minimizes air flow disturbance.



Innovation in Thermal Management™



**HP 1000-20** - Hand Held Probe  
Allows for measurement of velocity and temperature at the inlet and exhaust of systems.

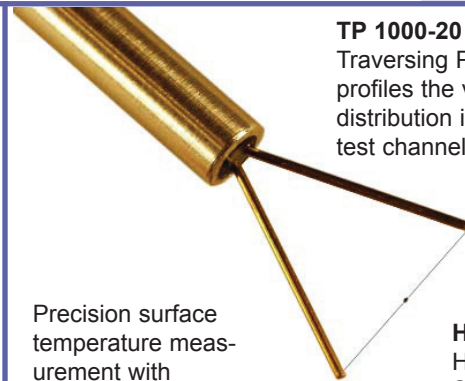

**TP 1000-20**  
Traversing Probe  
profiles the velocity distribution in the test channel.

Precision surface temperature measurement with **HP 1000-SP-20** probe.

**HP 1000-SP-20**  
Hand Held  
Surface Probe



**MS 1000-IP-20**  
Multi Sensor In Plane

Multi sensor probes designed for measurement of air fluid velocity and temperature in the same vertical plane. This eliminates the need for multiple probes or a traversing probe for determining the flow profile.

**MS 1000 PBL-20**  
Multi Sensor PBL



**SP 1000-20**  
Spot Sensor

Need to measure surface temperature?  
Use SP 1000-20 probe with your ATVS-2020™ system to determine surface temperature of your components, boards and heat sinks.











**MIC 1000-20**  
Measuring velocity & temperature in tough to reach areas.



Innovation in Thermal Management

# Sensors

## ATVS and eATVS Family of Sensors

Candlestick Sensor MS 1000-CS-WC		<p>Base Dia: 0.37" (9.5mm) Height: 0.35", 0.47", 0.78" (9mm, 12mm, 20mm)</p> <p>The Candlestick sensor is used for temperature &amp; velocity measurement.</p>
Uni-Sensor Reach Probe US 1000-RP-20		<p>Base Dia: 0.375" (0.95mm) Height: 0.5" (13mm)</p> <p>This uni-sensor is used for temperature and velocity measurement in tough to reach areas. The sensor can be placed in any angle or length to overcome to difficult to reach areas</p>
Multi Sensor In Plane MS 1000-IP-20		<p>Base Dia: 0.6" (15.2mm) Height: 0.53", 0.73", 0.92" (13mm, 18mm, 23mm)</p> <p>This three-sensor probe is designed for measurement of fluid velocity and temperature in the same vertical plane. It eliminates the need for multiple probes or a traversing probe for determining the flow profile or distribution.</p>
Multi Sensor PBL MS 1000-PBL-20		<p>Base Dia: 0.6" (15.2mm) Height: 0.53", 0.73", 0.92" (13mm, 18mm, 23mm)</p> <p>This three-sensor probe is designed for measurement of fluid velocity and temperature in three different height levels. It eliminates the need for multiple probes or a traversing probe for determining the flow profile or distribution.</p>
Hand Held Probe HP 1000-20		<p>Diameter: 0.18" (4.7mm) Length: 24" (609.6mm)</p> <p>HP1000 is a uni-sensor, hand-held probe for measurement of the temperature and velocity. The telescopic probe allows for measurement of velocity and temperature at the inlet and exhaust of systems. Its small aspect ratio minimizes flow disturbance induced as the result of the probe in the flow field.</p>
Hand Held Surface Probe HP 1000-SP-20		<p>Diameter: 0.17" (4.3mm) Length: 6" (150mm)</p> <p>HP 1000-SP is a stainless steel uni-sensor hand-held probe designed for the measurement of surface temperature of solids. Its pointed tip allows for exact positioning of the sensor on the desired spot. The design eliminates any conduction heat transfer through the stem, hence, enhancing measurement accuracy.</p>
Traversing Probe TP 1000-20		<p>Diameter: 0.25" (6.4mm) Length: 6" (150mm)</p> <p>TP1000 is a stainless steel traversing probe designed for the measurement of air velocity &amp; temperature. The probe is used to obtain velocity and temperature profiles at different locations in the same plane. Its small sensor has a high rate of response, making the sensor ideal for high-speed flow measurement. The sensor will require support for the purpose of traversing.</p>
Micro Sensor MIC 1000-20		<p>Length: 1.5" (38.1mm)</p> <p>This micro sensor is designed for measurement of fluid velocity and temperature in areas which are densely packed and space between boards is less than 4mm. The thickest part of this micro sensor is 3.2mm.</p>
Spot Sensor SP 1000-20		<p>Diameter: 0.02" (0.5mm) Length: Customizable</p> <p>This micro sensor is designed for measurement of fluid velocity and temperature in areas which are densely packed and space between boards is less than 4mm. The thickest part of this micro sensor is 3.2mm.</p>

# Candlestick Sensor™



**ATS** ADVANCED  
THERMAL  
SOLUTIONS, INC.  
Innovations in Thermal Management®

Measures temperature and air velocity  
with minimal flow disturbance

The Candlestick Sensor from Advanced Thermal Solutions, Inc., is a flexible, robust, base-and-stem design sensor that measures both temperature and air velocity for characterizing thermal conditions in electronic systems.

The Candlestick Sensor is narrow and low profile to minimize the disturbance of the heat flow in the test domain. It features a flexible, plastic-sleeved stem, which facilitates installation and repositioning during the testing process.

Sensors are calibrated for low (natural convection) and high velocity flows. They are capable of temperature measurements ranging from  $-30^{\circ}$  to  $+150^{\circ}\text{C} \pm 1^{\circ}\text{C}$ . Velocity measurements range from 0 to 50 m/s (10,000 ft/min)  $\pm 2\%$ , depending on the particular model of sensor.

The use of a single sensor to measure both temperature and velocity eliminates errors that can occur when airflow is non-isothermal. Multiple Candlestick Sensors can be easily installed to thoroughly map a system's thermal and airflow conditions. Their robust nature allows for continuous repositioning and reading.

Note: Sensor models are specific to particular ATS instrument systems. Please contact a sales representative for details.



#### HEIGHT

9 mm, 12 mm, 20 mm

#### BASE DIAMETER

9.5 mm

#### SENSOR STEM DIAMETER

0.5 mm

#### SENSOR BEAD DIAMETER

1.1 mm

#### VELOCITY MEASUREMENTS

0 to 6 m/s or 0 to 50 m/s

#### TEMPERATURE MEASUREMENTS

$-30^{\circ}$  TO  $+150^{\circ}\text{C} \pm 1^{\circ}\text{C}$

- » Offers the most accurate reading in Hot Wire Anemometry
- » Ideal for conditions where rapid measurement or flow control is required
- » Can be placed anywhere in the testing domain
- » Measures both temperature and velocity in a single package
- » Pre-calibrated sensors
- » All plastic design prevents shorting of electronics
- » Double-sided adhesive makes sensors easy to mount on any surface
- » Available in 9, 12 and 20mm heights
- » Can be used in flow measurements up to, and beyond, 10,000 feet per minute (50 meters per second)
- » Compatible with most ATS instrument systems including: ATVS-2020, eATVS-4/8, ATVS-NxT, WTC-100, ISD, ISD-9

For further technical information, please contact Advanced Thermal Solutions, Inc. at **781-769-2800** or [www.qats.com](http://www.qats.com)

RoHS Compliant



## Temperature and Velocity Measurement with Analog Output

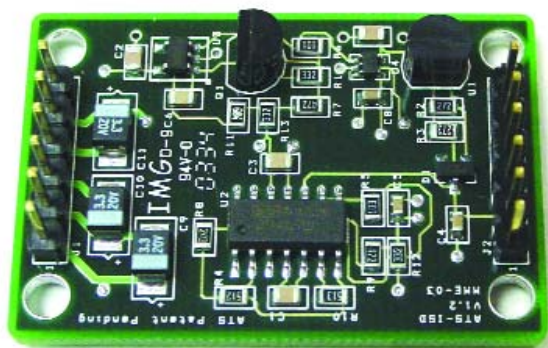

The ISD™ is designed to measure air flow temperature and velocity using two sensors. The ISD™ board is used for independent applications that require high speed data rate using data acquisition cards provided by the user. It has two independent sensors for determining air temperature and velocity to facilitate rapid feedback of the airflow inside the measurement area or, if required, simply for direct measurement of the flow parameters. It has two analog voltage outputs from 0 to 5 Volts for the two sensors. It can be provided with a LabVIEW™ VI to convert the voltages into temperature and velocity if the unit is purchased with the calibrated sensors and the user has capability to read the analog voltages. It requires a triple output DC power supply with +5V, +15/+12V and -15/-12V for its operation.

### Technical Data

- **Temperature Range:** -30°C to 150°C (it can be customized for different temperature ranges)
- **Velocity Range:** 0.3 to 50 m/sec (60 to 10,000 ft/min) if sensors are purchased precalibrated
- **Length:** 1.60" (39.68 mm)
- **Width:** 1.06" (26.98 mm)
- **Height:** 0.41" (10 mm)
- **Weight:** 6 grams
- **Two independent temperature and velocity sensors**
- **LabVIEW™ based VI**
- **Power Requirements:** 115 Volt AC Input with 3 DC outputs +5V, +15/+12V, -15/-12V (not included -- can be purchased separately)

### ISD™ Features

- Two independent sensors.
- Simultaneous measurement of velocity and temperature.
- 0 - 5VDC analog output for the velocity and temperature.
- 0 - 5VDC analog output for the temperature circuit.
- 115 volt AC to power supply with DC outputs of +5V, +15/+12 V and -15/-12 V.
- Can be used in a computer feedback control and measurement with mobile sensors that can be placed anywhere in the test domain.
- Compact and small platform PCB designed for condition where rapid measurement or flow control is required.
- Several ISD can be integrated on to one PCB for multi-point measurement of velocity and/or temperature.
- High precision system capable of measuring temperature from -30°C to 150 °C and velocity from 0 to 50 m/sec **without the need to change sensors or know the flow a priori.**



Innovation in Thermal Management™

# ISD-232™

## Temperature and Velocity Measurement with Digital Output

### ISD-232™ Features

- Two independent sensors.
- Simultaneous measurement of velocity and temperature.
- 115 volt AC to power supply with DC outputs of +5V, +15/+12 V and -15/-12 V.
- Computer feedback control and measurement with mobile sensors that can be placed anywhere in the test domain.
- Compact and small PCB designed for conditions where rapid measurement or control is required.
- Multiple ISD-232™ can be used for multi-point measurements once used with a multi-port RS232 system .
- High precision system capable of measuring temperature from -30 °C to 150 °C and velocity from 0 to 50 m/sec **without the need to change sensors.**

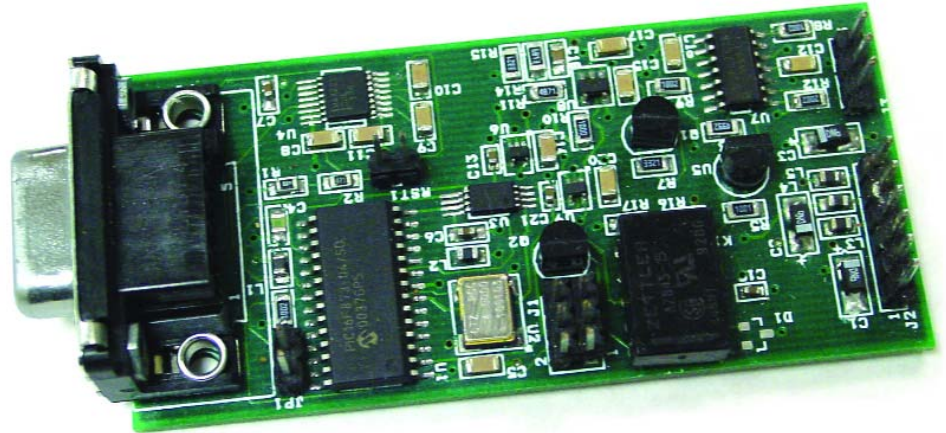

ISD-232™ is designed to measure air flow temperature and velocity using two sensors. The ISD-232™ board is used for independent applications that require high speed data rate. It has two independent sensors for determining air temperature and velocity to facilitate rapid feedback of the airflow inside the measurement area or, if required, simply for direct measurement of the flow parameters. It is provided with a LabVIEW™ VI to convert the voltages into temperature and velocity if the unit is purchased with the calibrated sensors supplied by Advanced Thermal Solutions, Inc. It requires a triple output DC power supply with +5V, +15/+12V and -15/-12V for its operation.

### Technical Data

- **Temperature Range:** -30°C to 150°C (it can be customized for different temperature ranges)
- **Velocity Range:** 0.3 to 50 m/sec (0 to 10,000 ft/min) if sensors are purchased pre-calibrated
- **Length:** 3.34" (84.8 mm)
- **Width:** 1.44" (36.5 mm)
- **Height:** 0.55" (13.9 mm)
- **Weight:** 26 grams
- **Two independent temperature and velocity sensors**
- **LabVIEW™ based VI software for operation (included)**
- **Power requirements: 115 Volt AC Input with 3 DC Outputs +5V, +15/+12V, -15/-12V (not included -- can be purchased separately)**

# thermVIEW™

## Liquid Crystal Thermographic Analysis Tool

thermVIEW™ is a high resolution liquid crystal thermography system for cost effective temperature measurement of electronic circuit boards, micro circuits, hybrids, components and integrated circuits.

### What is liquid crystal thermography? (LCT)

thermVIEW™ system uses the color response of thermochromic liquid crystals (TLC) for the purpose of temperature measurement. Liquid crystals reflect incident light at the visible wavelength based on the temperature of the surface to which they are applied.

- **Does the chip or the board get destroyed as the result of ink/LC application?**  
No, ink and LC can be washed off with de-ionized water.
- **Can one reuse the LC treated surface?**  
Yes, as long as the surface is kept in a clean environment.
- **How often do I need to calibrate?**  
Typically every time the LC is applied to a new surface - a good measurement practice.
- **Are liquid crystals harmful?**  
No, but we do not recommend consuming them.
- **Can you use it for board level measurement?**  
Yes, LC can be used for any surface that can be treated with LC and trackable lighting.
- **Can you mix different liquid crystal compounds?**  
Yes, however, it will be difficult to determine the temperature because the same colors, reflecting a temperature, will appear repeatedly as the surface is heated.

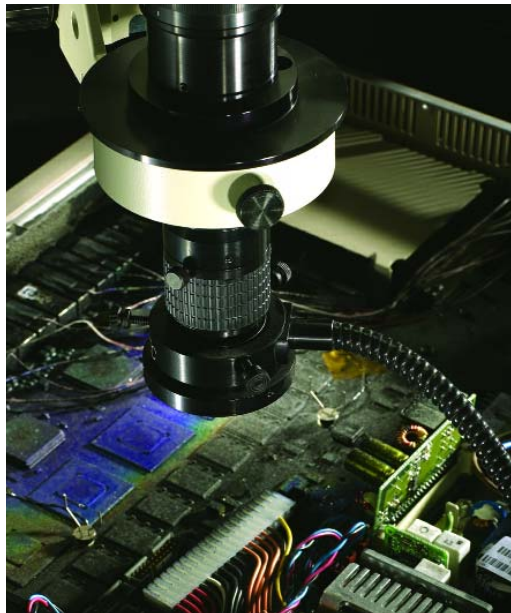

	IR Thermography	LC Thermography	Remarks
Test specimen surface treatment	Yes	Yes	Required for both systems for good measurement
Steady state measurement	Yes	Yes	
Transient measurement	Yes	Yes	
Non-evasive measurement	Yes (emissivity* dependent)	No	*Must know the emissivity for the IR system
PC based	Yes	Yes	
Software for image analysis and acquisition	Yes	Yes	
Effect of ambient temperature	Yes*	No	*To the level that may impact specimen temperature
Ease of use	Yes	Yes	
Video imagery	No	Yes	
Compactness and transportability	Yes	Yes	
Resolution			
<b>Temperature</b>	+/- 2°C	+/- 0.1°C	
<b>Spatial</b>	5 micron	less than 1 micron	
Price			
<b>Base system</b>	\$45 - 70,000	\$34,000*	*(estimate)
<b>Microscopic (part level)</b>	\$180,000	\$45,000*	* starting at (estimate)

\* Price subject to change







Innovation in Thermal Management™

# thermVIEW™

## Liquid Crystal Thermographic Analysis Tool

### thermVIEW™ Features

- One micron spatial, 0.1°C thermal resolutions.
- User-calibrated temperature accuracy to +/- 0.1°C.
- Color/Temperature key with cursor link indicates temperature at cursor location.
- Temperature profile can be observed without microscope for cursory observations or with microscope for more precise analysis.
- Thermography can be performed even by viewing through glass or transparent plastic.
- View physical and thermographic images simultaneously.
- Thermal image analysis with capability to select thermal and spatial regions of interest.
- On-screen temperature probe.
- Automatic calibration system for liquid crystal temperature response.
- thermSOFT™, a thermal image analysis software with temperature and position indicators.



thermVIEW™ is a high resolution liquid crystal thermography system for cost effective temperature measurement of electronic circuit boards, micro circuits, hybrid components and integrated circuits.

### System Components

- High performance, solid-state, color camera with micro or macro-scopic optics
- Stable, flicker-free white light source
- High speed digital, color frame-grabber
- State-of-the-art color temperature calibration device
- PC computer platform
- Thermochromic Liquid Crystal (TLC) materials supplied in an easy to use kit
- thermVIEW™ image processing software system, thermSOFT™

### Applications

- **One micron level\* thermal mapping of electronic devices (not possible with IR systems)**
- **Locate hot spots and defects**
- **IC thermal design and verification**
- **Accurate temperature measurement on micron size hot spots on microcircuits, components, modules, and PCBs**
- **State-of-the-art thermal analysis of devices**
- **Comparative failure analysis**
- **Live (transient) thermal analysis (30 images per second)**

\*0°C to 90°C less than 1 micron spatial resolution with unencapsulated liquid crystal  
0°C to 160°C minimum 5 micron spatial resolution with encapsulated liquid crystal



The turnkey **thermVIEW™** Thermo-chromic Liquid Crystal based temperature measurement system performs high-resolution thermography with precise temperature accuracy and micron level spatial resolution. The system provides greater range and flexibility while it is more cost-effective than alternative technologies. Applications for thermVIEW™ exist in a wide range of industries, including electronics thermal management and failure analysis, gas turbine heat transfer industries and academic laboratories.

The **thermVIEW™** system uses the color response of thermochromic liquid crystals (TLC) for the purpose of temperature measurement. Liquid crystals reflect incident light at the visible wavelength based on the temperature of the surface to which they are applied. The temperature response of liquid crystal is called the event temperature. When the surface is illuminated by white light and viewed under fixed optical conditions, the TLC material will reflect a unique wavelength distribution of visible light (i.e., color). As the temperature rises through the TLC's bandwidth, the reflected color of the TLC will change. Finally, when the temperature exceeds the TLC's clearing point temperature, the material will enter the pure liquid state and will revert back to being transparent. This phenomenon is selective reflection and occurs in most TLCs both on heating and cooling, and occurs with minimal hysteresis.

The reflected color distribution for most TLC materials will vary continuously from the longer wavelengths (i.e. red) corresponding to the event temperature to shorter wavelengths (i.e. blue) corresponding to the clearing point temperature. Additionally, a TLC material will also transmit a significant amount of the incident light with virtually no modification. This color-temperature response can then be captured by a color camera, formulated into a calibration curve of color versus temperature and used to transform a color measurement system into a very accurate TLC based thermography system.

In building efficient TLC-based thermography systems, thermVIEW™ technology and performance surpasses all other available methods,

including Infra Red thermography.

### TLC Color Temperature Calibration

thermVIEW™ built-in features allow fully automatic color-temperature calibration of virtually any TLC formulation available via the patented RS-232-enabled calibration device. This device permits the color-calibration data to be acquired by simultaneously using the camera to record the color response while it is being subjected to successively higher levels of temperature on a solid-state, PID-controlled test surface. The software then analyzes the color/temperature response and builds the calibration data.

### Thermograph Analysis Tools

thermVIEW™ analysis tools provide users with dynamic data-probing capabilities with point value and linked X-Y data profile display. Users can interactively calibrate the physical-to-screen coordinate system for any image being analyzed. This feature gives thermVIEW™ operators a very simple and direct mechanism to make spatial measurements of the thermal phenomena present in their thermographs.

### Processing Tools

thermVIEW™ processing tools allow users to “extract” a color or temperature image plane with Region Of Interest (ROI) control, create and apply “masks” (aids in determining valid regions of the image), perform thresholding and apply spatial filters on a loaded image interactively. Automatic conversion to temperature in user specified units (°C, °F, K, R) is supported using the TLC color-temperature calibration data.

### Image Acquisition/Storage Software Features

thermVIEW™ has integral support for live, “on-the-fly” image acquisition, averaging and storage (TIFF file format) features. These include ROI specification using the built-in IMAQ Vision ROI tools along with full control of the frame grabber settings such as scaling and calibration. The system also supports image retrieval from disk for post-processing of archived images.

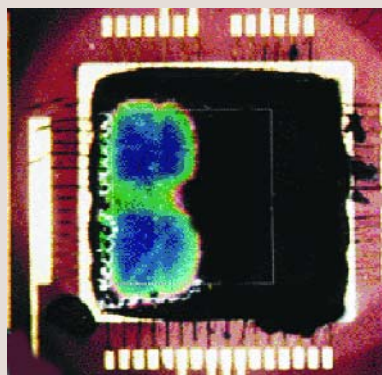
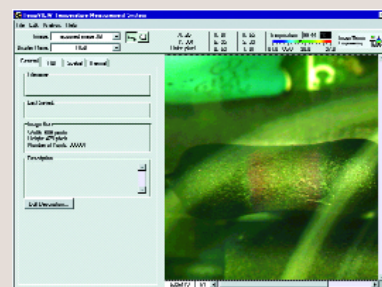
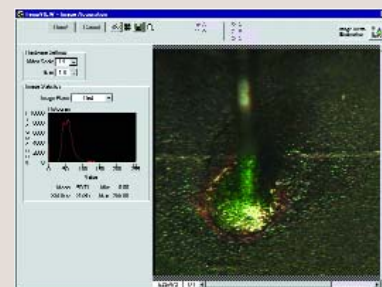



Innovation in Thermal Management™

# thermKIT™

## Liquid Crystal Thermography Kit



As used in  
ThermVIEW™  
Liquid Crystal  
Thermography  
System



- Compressed air canister
- DI-water
- Heat gun
- Heat gun adapter
- Liquid crystal and black paint spray
- Liquid crystal solutions and paste
- Air tubes for the sprayer
- Black ink
- Cleaning jar
- Beaker
- Magnifying lens
- Filter boxes
- Application brushes
- Swabs
- Safety glass
- Syringes
- Black ink
- Mask
- Wipes
- Gloves

### Broad Bandwidth, 5°C Range:

Item	Part #	Red Start	Range	Qty
A	R20C20W	20°C	20°C to 40°C	250 grams
B	R40C20W	40°C	40°C to 60°C	250 grams
C	R60C20W	60°C	60°C to 80°C	250 grams
D	R80C20W	80°C	80°C to 100°C	250 grams
E	R100C20W	100°C	100°C to 120°C	250 grams
F	R120C20W	120°C	120°C to 140°C	250 grams

### Narrow Bandwidth, 5°C Range:

Item	Part #	Red Start	Range	Qty
G	R30C5W	30°C	30°C to 35°C	250 grams
H	R40C5W	40°C	40°C to 45°C	250 grams
I	R50C5W	50°C	50°C to 55°C	250 grams
J	R60C5W	60°C	60°C to 65°C	250 grams
K	R70C5W	70°C	70°C to 75°C	250 grams
L	R80C5W	80°C	80°C to 85°C	250 grams
M	R90C5W	90°C	90°C to 95°C	250 grams
N	R100C5W	100°C	100°C to 105°C	250 grams
O	R110C5W	110°C	110°C to 115°C	250 grams
P	R120C5W	120°C	120°C to 125°C	250 grams



# PTM-1000

**DIFFERENTIAL PRESSURE TRANSDUCER FOR HIGHLY ACCURATE MEASUREMENTS  
WITHIN ELECTRONIC SYSTEMS**

The PTM-1000™ Pressure Transducer Module is a four-channel test instrument for measuring differential pressure in enclosures where air flow integrity is critical to proper performance. As the demand for more energy efficient cooling grows, the need for measuring the pressure at each source of heat generation will follow.



In thermal characterization applications, the PTM-1000 is capable of measuring pressure drop across channels in circuit cards and assemblies; differential pressure across Pitot tubes, orifice plates and venturi tubes; intake to exhaust pressure drop in forced convection cooling systems and pressure drop across in-line filters, to name a few.

The PTM-1000 Pressure Transducer Module includes user-friendly stagePRESSURE™ application software, which provides easy data viewing and logging. The user can save four channels of pressure data as a function of elapsed time for study of raw data history.

The system is available in two pressure ranges; 0-0.15 PSI and 0-0.30 PSI, the ideal for precise measurements within telecommunications, networking, embedded computing and other high performance electronic applications. Data accuracy is within 1% of the full scale. The pressure transducer is capable of measuring pressure at temperatures from -40° to 120°C with data accuracy within 1% of full scale.

The PTM-1000 pressure transducer connects to a PC via a USB socket to acquire power and data communications. It can be powered by a 5 volt power supply and provides four independent 0-5V analog output signals proportional to the pressure of each channel. These features enable the system to be easily integrated into other control circuits that require analog voltage as input signals.

ATS also offers its pressure transducer as a standalone board, the PTB-1000, for OEM applications or system integration.



**AVAILABLE PRESSURE RANGES**  
0-0.15 PSI, 0-0.30 PSI

**OPERATING TEMPERATURE RANGE**  
-40° to 120°C

**COMPENSATED TEMPERATURE RANGE**  
0 to 70°C

**STORAGE TEMPERATURE**  
-55° to 135°C

**CONNECTION TYPE**  
USB

**OVERALL DIMENSIONS (L X W X H)**  
233.17 mm x 144.38 mm x 60.02 mm  
(9.18" x 5.68" x 2.36")

## FEATURES:

- » **Highly Accurate**  
Provides accurate data to within 1% of the full scale
- » **Low Pressure Measurement**  
From 0-0.15 PSI or 0-0.30 PSI. Additional pressure ranges available as custom options from 0-100 PSI
- » **stagePRESSURE™ Software**  
User friendly application for easy data viewing and logging
- » **USB Connection**  
Provides power and signal communication
- » **0-5V Output Analog Voltage**  
For integration into control circuits that require analog voltage as input signals

## APPLICATIONS:

- » **Telecommunications**
- » **Networking**
- » **Embedded Systems**
- » **Automotive**
- » **Medical Instrumentation**
- » **Pneumatic Control**
- » **HVAC**
- » **Airflow Monitors**
- » **Thermal Management**

For further technical information, please contact Advanced Thermal Solutions, Inc. at **1-781-769-2800** or **www.qats.com**



# PTB-1000

DIFFERENTIAL PRESSURE TRANSDUCER BOARD FOR HIGHLY ACCURATE MEASUREMENTS WITHIN ELECTRONIC SYSTEMS

The PTB-1000™ Pressure Transducer Board is a four-channel test instrument for measuring differential pressure in enclosures where air flow integrity is critical to proper performance. As the demand for more energy efficient cooling grows, the need for measuring the pressure at each source of heat generation will follow.

In thermal characterization applications, the PTB-1000 is capable of measuring pressure drop across channels in circuit cards and assemblies; differential pressure across Pitot tubes, orifice plates and venturi tubes; intake to exhaust pressure drop in forced convection cooling systems and pressure drop across in-line filters, to name a few.

The PTB-1000 Pressure Transducer Board includes user-friendly stagePRESSURE™ application software, which provides easy data viewing and logging. The user can save four channels of pressure data as a function of elapsed time for study of raw data history.

The system is available in two pressure ranges; 0-0.15 PSI and 0-0.30 PSI, the ideal for precise measurements within telecommunications, networking, embedded computing and other high performance electronic applications. Data accuracy is within 1% of the full scale. The pressure transducer is capable of measuring pressure at temperatures from -40° to 120°C with data accuracy within 1% of full scale.

The PTB-1000 pressure transducer connects to a PC via a USB socket to acquire power and data communications. It can be powered by a 5 volt power supply and provides four independent 0-5V analog output signals proportional to the pressure of each channel. These features enable the system to be easily integrated into other control circuits that require analog voltage as input signals.

ATS also offers its pressure transducer as an enclosed module, the PTM-1000.



**AVAILABLE PRESSURE RANGES**  
0-0.15 PSI, 0-0.30 PSI

**OPERATING TEMPERATURE RANGE**  
-40° to 120°C

**COMPENSATED TEMPERATURE RANGE**  
0 to 70°C

**STORAGE TEMPERATURE**  
-55° to 135°C

**CONNECTION TYPE**  
USB

**OVERALL DIMENSIONS (L X W X H)**  
71 mm x 67 mm x 20 mm  
(2.79" x 2.63" x 0.78")

## FEATURES:

- » **Highly Accurate**  
Provides accurate data to within 1% of the full scale
- » **Low Pressure Measurement**  
From 0-0.15 PSI or 0-0.30 PSI. Additional pressure ranges available as custom options from 0-100 PSI
- » **stagePRESSURE™ Software**  
User friendly application for easy data viewing and logging
- » **USB Connection**  
Provides power and signal communication
- » **0-5V Output Analog Voltage**  
For integration into control circuits that require analog voltage as input signals

## APPLICATIONS:

- » **Telecommunications**
- » **Networking**
- » **Embedded Systems**
- » **Automotive**
- » **Medical Instrumentation**
- » **Pneumatic Control**
- » **HVAC**
- » **Airflow Monitors**
- » **Thermal Management**

For further technical information, please contact Advanced Thermal Solutions, Inc. at **1-781-769-2800** or **www.qats.com**

# WTC-100™

## Wind Tunnel Controller

The WTC-100™ is a device to control the air velocity in a chamber-like wind tunnel or card rack.

The WTC-100™ helps automate thermal characterization of heat sinks, boards and components in a wind tunnel or card rack testing for different fan tray configurations. It has two independent sensors for determining air temperature and velocity to facilitate rapid feedback of the airflow inside the test chamber. The controller communicates with a PC through an RS-232 port, enabling the user to fully automate air flow testing. Uni-sensor based control and measurement enables the user to control the air flow anywhere inside the test chamber.

The flow range, step increment and the dwell time are set from the stageCONTROL™ application software by the user.

### Technical Data

- **Width** 10.40" (264 mm)
- **Length** 13.80" (350 mm)
- **Height** 4.5" (114.6 mm)
- **115 volt AC input power**
- **Fan operating voltage** 24 Volts (Can be changed to a different fan voltage)
- **Velocity range** 0.2 to 50 m/sec (60 to 10,000 ft/min) **DEPENDING on the fan tray**
- **Two independent temperature and velocity sensors**
- **RS232 Connector port**
- **stageCONTROL™ labVIEW™ based application software**



Front View



Rear View

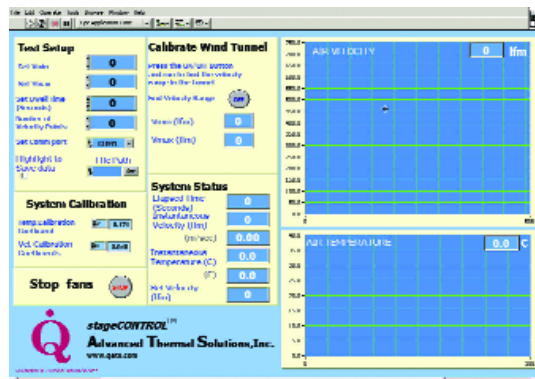

stageCONTROL™



Innovation in Thermal Management™

### WTC-100™ Features

- Fully automatic controller for components, heat sink and card rack characterization.
- Two independent sensors for measuring air temperature and velocity simultaneously
- Feed back control to maintain air velocity in the test domain within +/- 0.5% of the set velocity.
- Control velocities from 60 to 10,000 ft/min depending on the system fan tray.
- Measures temperatures from -10 °C to 150 °C.
- Enables ramping of flow from a set minimum to a set maximum at specified number of points.
- Sets dwell time at each measurement point.
- Standard unit powers up 24 VDC fans (different voltage fans can be used upon request).
- stageCONTROL™, a user friendly labVIEW™ based application software.
- RS232 connection to a PC.
- 115 volt AC input power.
- WTC-100™ saves testing time by facilitating automatic air flow control and measurement.



# CLWTC-1000

**AUTOMATIC CONTROLLER FOR THE CLWT-067 CLOSED LOOP, BENCHTOP WIND TUNNEL**

Custom built for the CLWT-067 closed loop wind tunnel, the CLWTC-1000™ is designed to automatically control the air flow and temperature through the test chamber. The controller is operated with a Windows PC (not included) to manage and measure air speed and air temperature, and to obtain continuous data on the devices under test.



The CLWT-1000 controller features easy to use StageControl 1000™ software, a version of the proven software used with other ATS wind tunnel controllers. The controller provides the PC with a functioning Data Center for viewing information and monitoring events. The user can set a range of velocities at different temperatures from the software to run the wind tunnel automatically. The CLWTC-1000 also has manual controls to raise and lower the air temperature, in addition to changing temperature via the PC.

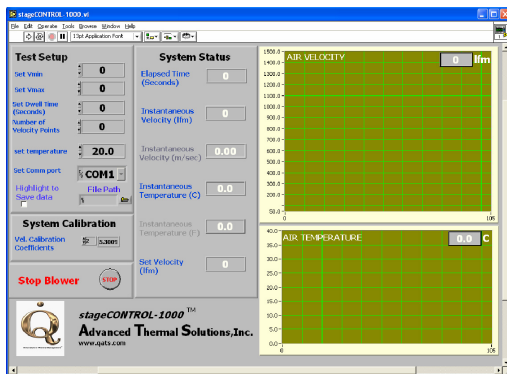

The CLWTC-1000's interface is compatible with any Windows PC.

It is highly recommended that users of the CLWT-067 utilize the CLWTC-1000 Closed Loop Wind Tunnel Controller as it automates the control of temperature and velocity automatic and minimizes the chances for errors using multiple and/or less capable controlling devices.

**OVERALL DIMENSIONS (L X W X H)**  
34.3 cm x 25.4 cm x 17.8 cm  
(13.5" x 10" x 7")

**MATERIALS**  
SHEET METAL

**FLOW RANGE**  
0 TO 7.5 m/s (1500 ft/min)

**TEMPERATURE RANGE**  
Up to 85°C (185°F)

**WEIGHT**  
4.5 kg (10 lbs.)

\*RoHS Compliant

## FEATURES:

- » **Data Center**  
View data and monitor wind tunnel events at the data center
- » **Temperature Control**  
Precisely controls wind tunnel temperatures up to 80°C
- » **Velocity Control**  
Controls the fan RPM and allows changes in air flow rates

## APPLICATIONS:

- » **High Temperature Testing**  
Users can evaluate the effects of elevated temperatures on component and PCB response and reliability
- » **Heat Sink Characterization**  
Characterize a variety of heat sink sizes for low speed and forced convection cooling
- » **Sensor Calibration**  
Precision temperature and velocity controls allow accurate calibration of sensors
- » **Component Testing**  
An ideal test vehicle for individual or multiple component testing
- » **Multiple PCB Testing**  
Test actual or simulated PCBs for thermal and flow distribution

For further technical information, please contact Advanced Thermal Solutions, Inc. at **1-781-769-2800** or **www.qats.com**

# HP-97-1/2™

High Power Component Simulators



**ATS** ADVANCED  
THERMAL  
SOLUTIONS, INC.  
Innovations in Thermal Management®

ATS' HP-97 Series are high-power component simulators used for replicating the heat dissipation conditions of devices. It features a 32 x 32 mm Aluminum block and a cartridge heater embedded within a high temperature DERLIN® housing and mounted to an FR4 plate. DERLIN® is known for its stiffness, dimensional stability, impact resistance, and structural strength.

Typical applications for HP-97 Component Simulators include heat sink characterization and side-by-side heat sink comparison. Each Component Simulator has a temperature range of ambient to 110° C, ideal for most heat sink testing applications. Each unit is designed to fit within most Advanced Thermal Solutions, Inc. bench top, open loop and closed loop wind tunnels.

Heat sinks are mounted to the component simulators via double-sided adhesive thermal tape. Custom attachment options are also available. A power source is required for operation. Thermal tape and power source are not included.

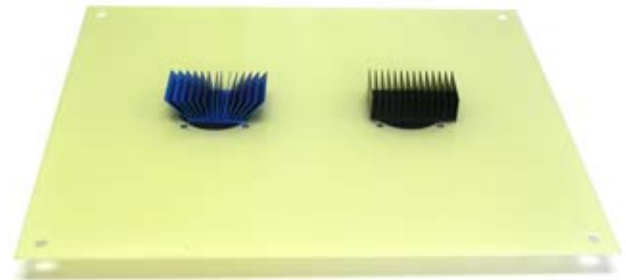
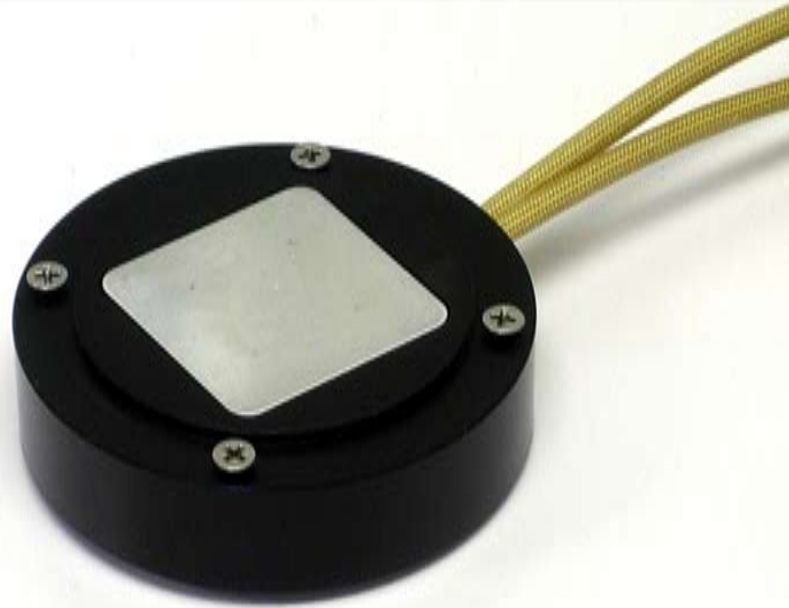

HP-97-2 Shown in a typical side-by-side heat sink comparison application.

#### PLATE DIMENSIONS (L X W)

33.65 cm X 29.21 cm  
(13.25" X 11.5")

#### SIMULATOR DIMENSIONS (D X H)

6.35 cm X 1.93 cm  
(2.5" X 0.76")

#### HEATER BLOCK DIMENSIONS (L X W)

3.175 cm X 3.175 cm  
(1.25" X 1.25")

#### POWER REQUIREMENTS

110 V OR 220 V (INTERNATIONAL)

#### TEMPERATURE RANGE

AMBIENT TO 110° C



HP-97-1 Single Component Simulator

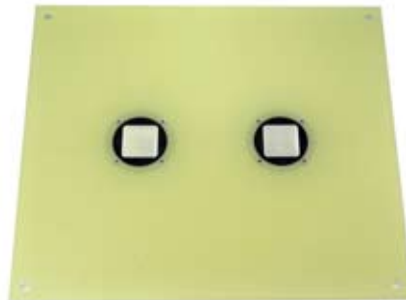

HP-97-2 Dual Component Simulator

For further technical information, please contact Advanced Thermal Solutions, Inc. at **781-769-2800** or [www.qats.com](http://www.qats.com).

RoHS Compliant





# CIP-1000™

CONTROLLABLE ISOTHERMAL PLATE SYSTEM FOR A HIGHLY ACCURATE, ADJUSTABLE HEAT SOURCE

The CIP-1000, Controllable Isothermal Plate is a system for providing an isothermal surface that can be precisely temperature-controlled from 10 to 170°C with an accuracy of +/- 0.1°C.

The CIP-1000 system features a 75 mm diameter isothermal copper plate whose constant temperature can be raised or lowered both automatically and manually. A three wire RTD sensor and integral PID controller ensure specific, uniform temperature across the entire plate.

The laboratory-quality CIP-1000 system includes a separate controller unit that allows both pre-programmed and hands-on temperature management. The controller communicates with a PC through a choice of either a USB or RS232 connection. The included stageTHERM™ software allows easy temperature variation of the isothermal plate for testing and other applications. Different plate temperature settings can be programmed for automated ramping, including hold times for each step. Alternatively, the temperature of the plate can be manually adjusted in increments as small as 0.1°C using the system's digital controls.

Time and temperature data are accurately recorded and can be downloaded or viewed in easy to read graphs and tables. If needed, the CIP-1000 plate is easily removable for rework, surface treatment, attaching DUT and other such tests. The system can also be customized for special applications including larger plates and different temperature ranges.

The CIP-1000 system can be used in a wide range of applications, including component and environmental testing, product development, quality control and life science studies.



Controller



Front



Bottom

#### SENSOR TYPE

Three-wire 100 Ohm RTD

#### SURFACE TEMPERATURE RANGE

10°C to 170°C

#### CONTROLLER ENVIRONMENTAL TEMPERATURE

0 to 50°C

#### LONG TERM TEMPERATURE STABILITY

Less than 0.002°C

#### DISPLAY RESOLUTION

Less than 0.1°C

#### CONTROLLER DIMENSIONS (L X W X H)

269.25 mm x 182.9 x 124.45 mm  
(10.6" x 7.2" x 4.9")

#### PLATE ASSEMBLY DIMENSIONS

114.5 mm x 78.75 mm (4.5" x 3.1")

#### PC CONNECTIONS

USB, RS232

#### POWER

115/230 VAC, 50-60 Hz

#### FEATURES:

- » **Wide Temperature Range**  
Produces surface temperatures from 10°C to 170°C
- » **Highly Accurate Control**  
Temperature can be controlled to less than 0.1°C display resolution
- » **Fully Programmable**  
Plate temperature settings can be programmed for automated ramping, including hold times for each step
- » **Removable Copper Plate**  
CIP-1000 plate is easily removable for rework, surface treatment, attaching DUT and other such tests
- » **PID Control**  
Unipolar or bipolar, PID control with auto-tuning capability

#### APPLICATIONS:

- » **Telecommunications**
- » **Automotive**
- » **Medical Instrumentation**
- » **Thermal Management**
- » **Pharmaceuticals**
- » **Chemical**
- » **University Research**

For further technical information, please contact Advanced Thermal Solutions, Inc. at **1-781-769-2800** or **www.qats.com**

# Heat Flux Controller™

## HFC-100



- Dynamically measures the resistance of the heating element and adjusts the voltage to provide the desired power.
- Automatically shuts off if the heater temperature rises above the user defined protocol.

### Description and Benefits

The Heat Flux Controller™ is a high heat flux chip simulator capable of measuring and controlling the amount of heat in a resistive element. The HFC-100 comes with a chip simulator capable of dissipating 1k /cm<sup>2</sup>. The design of the heater block insures minimal heat loss to the ambient, hence a more accurate thermal resistance determination of either heat sinks or cold plates. This system features ATS proprietary fluxSTAGE™, a LabView™ application, which automates the use of the system and allows the user to choose multiple heat loads at a specific dwell time. The program calculates the thermal resistance of the cold plate for desired cooling of the die and measures the simulated junctions temperature.

### Technical Data

SPECIFICATION	HFC 100
WIDTH	16.73" (425mm)
LENGTH	22.0" (559mm)
HEIGHT	3.47" (88mm)
OUTPUT VOLT	UP TO 40 VDC
OUTPUT CURRENT	UP TO 25 AMP
OUTPUT POWER	UP TO 1KW
COMMUNICATION	USB
APPLICATION	LabView™ based
INPUT POWER	115 VOLT AC
OTHER	Automatically calculates cold plate or heat sink thermal resistance



**ADVANCED THERMAL SOLUTIONS, INC.**

89-27 Access Rd. Norwood, MA 02062, USA | Tel: 781-769-2800 Fax: 781-769-9979

Innovation in Thermal Management™



Innovation in Thermal Management™

- Automatic calculation of total thermal resistance
- Simulated chip capable of dissipating 1kW of heat over 1cm<sup>2</sup>
- Capable of transient steady state and transient measurements
- Simulated chip can be customized for any size
- Eight thermocouple sensors for temperature measurement
- User defined power levels and dwell times
- Dynamic control of the power dissipation
- Fully automated heat flux generator and measurement system
- Dynamically measures resistance of the heating element for accurate dissipation calculation.

www.qats.com



# FCM-100

## FAN CHARACTERIZATION MODULE

The FCM-100 Fan Characterization Module is a specialized unit designed to test and characterize fans of various sizes and performance outputs. Using the FCM-100 Module in conjunction with pressure measurement equipment (such as the PTM-1000) and velocity measurement equipment (such as the eATVS); it is possible to develop fan curves ( $\Delta P$  vs. Flow rate) that can be used to verify fan manufacturer data or to characterize fans of unknown performance.

The FCM-100 is constructed of sturdy corrosion resistant sheet metal, with casters for easy portability. A removable and customizable lexan mounting plate is provided to which fans of various diameters can be secured. Four (4) removable perforated flow restriction plates are also provided to allow the user to control the pressure drop through the module for fans under testing.

Customizable options include various sized specialized mounting plates can be made for the characterization of multiple fans simultaneously, including fan tray assemblies.

### RELATED PRODUCTS:



**eATVS-8**  
8-Channel Automatic  
Temperature & Velocity Scanner



**PTM-1000**  
Pressure Transducer Module

**OVERALL DIMENSIONS (L X W X H)**  
102.6 cm x 45.2 cm x 51.8 cm  
(40.4" x 17.8" x 20.4")  
(Length does not include fan.)

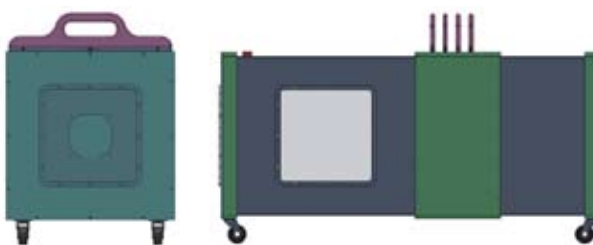
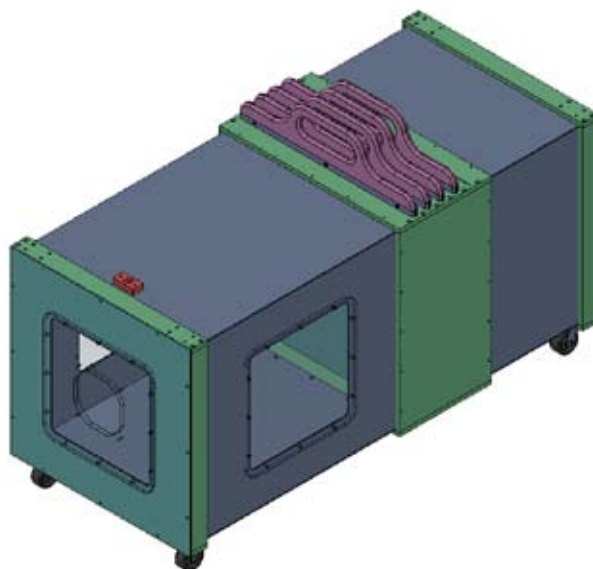

### FEATURES:

- » **Flow Restriction Plates**  
Includes four removable perforated flow restriction plates allowing the user to control the pressure drop through the module
- » **Portable**  
Features casters allowing the unit to be moved easily
- » **Sturdy Construction**  
For integration into control circuits that require analog voltage as input signals
- » **Customizable Options**  
Options include specialized mounting plates for the characterization of multiple fans simultaneously, including fan tray assemblies.
- » **Compatible Instruments**  
Can be used in conjunction with ATS' PTM-1000 Pressure Transducer Module and eATVS Automatic Temperature & Velocity Scanner to develop fan curves that can be used to characterize fans or verify manufacturer data.

### APPLICATIONS:

- » **Telecommunications**
- » **Networking**
- » **Embedded Systems**
- » **Thermal Management**

For further technical information, please contact Advanced Thermal Solutions, Inc. at 1-781-769-2800 or [www.qats.com](http://www.qats.com)

# Wind Tunnels

For thermal characterization



## Wind tunnels for all testing needs

ATS offers a host of research quality wind tunnels designed for component, board, & heat sink characterization. Transparent test sections provide optical access for flow visualization.



### CLWT-100™

- Uniform and homogenous flow at the test section due to its aerodynamic design.
- Insulated test section features front and side windows made of heat resistant multilayer glass panels for optical access.
- Twenty four sensor ports in the front and sides of the test section allow for insertion of a variety of thermal probes.
- Automated wind tunnel control utilizes ATVS-2000™ and stagePOINT™ technologies.

### CWT-100™

- Powered by variable DC fans mounted at the exit section of the tunnel.
- Replaceable fan tray to accommodate small or large fans.
- Uniform and homogeneous flow at the test section as a result of the internal flow management system.
- Custom designs available for larger/smaller test sections.



### BWT-100™

- A portable bench-top wind tunnel.
- All plexiglas for optical access.
- Simulates actual PCB air inlet to replicate the real application in testing.
- Operates horizontally or vertically to adapt to direction-sensitive electronic cooling systems.

	BWT-100™	CWT-100™	CLWT-100™
<b>HEIGHT</b>	22.75" (58 cm)	73" (185 cm)	112" (285 cm)
<b>WIDTH</b>	10.75" (27cm)	17.75" (45 cm)	45" (114cm)
<b>LENGTH</b>	22.75" (58cm)	73" (185cm)	78" (198cm)
<b>WEIGHT</b>	8 lbs. (4 kg)	60 lbs. (28 kg)	2000 lbs. (998 kg)
<b>ORIENTATION</b>	hor / vert	hor / vert	vertical
<b>TEST SECTION</b>			
<b>HEIGHT(wall to wall)</b>	1" (2.5cm)	3.25" (8.5cm)	1' (30cm)
<b>WIDTH</b>	8" (20cm)	11.5" (29cm)	1' (30cm)
<b>LENGTH</b>	11"(27.5cm)	13.25"(34cm)	1' (30cm)
<b>OPERATING TEMP.</b>	ambient	ambient	-10°C to 85°C ± 1°C
<b>VELOCITY RANGE (accuracy ± 2% @ velocity)</b>	0 - 400 ft/min (2 m/s)	0 - 1200 ft/min (6 m/s)	0 - 1000 ft/min (5 m/s)
<b>POWER REQUIREMENTS</b>	DC P.S.	DC P.S.	230 V single phase
<b>FLOW</b>	0 to 400 ft/min (2m/s)	0 to 1500 ft/min (6 m/s)	0 to 1000 ft/min (5m/s)



Innovation in Thermal Management™

# CLWT-100™

## Closed Loop Wind Tunnels

### CLWT-100™ Features

- **Automated Control**  
Wind Tunnel velocity and temperature is automatically controlled using PCS-1000™ technology.
- **Data Center**  
View data and monitor events at the data center (optional accessories not shown in the picture)
- **Unit Level**  
Characterization test section size permits prototype testing of rack mounted units.
- **Heat Sink Characterization**  
Characterize a variety of heat sink sizes for mixed and forced convection cooling.
- **PCB Testing** Single or Multiple  
Test actual or simulated PCBs for thermal and flow distribution.
- **Flow Visualization**  
Observe flow distribution in the tunnel through all test section windows.
- **Quick Access**  
Quickly change the test specimen through the rear access test section door.
- **Sensor Ports**  
Measure pressure, velocity and temperature through the port holes.
- **Flow Characteristics**  
High quality flow with very low turbulence intensity.
- **Test Section Fixturing**  
Adjustable fixturing is provided for specimen mounting.
- **CLWT-100™**  
is designed for electronic cooling testing.

The CLWT-100™ is a research quality wind tunnel designed for component, heatsink, printed circuit board, and unit level characterization. It can be used for flow characterization, flow visualization and thermal resistance measurements. The CLWT-100™ is a closed loop design capable of delivering air flows from 0 to 5 m/s and producing temperature ranges from -10°C to +85°C. It has aerodynamically designed ducts and flow management elements that provide uniform and homogenous flow in the test section. Air flow temperature control is achieved using conventional heaters and refrigeration units. Wind tunnel heat losses are minimized by a double wall design with thermal insulation. The test section is thermally insulated by a Delrin frame having front and side windows made of a heat resistant multi-layer glass panel for optical access and ease of flow visualization. There are 24 sensor ports in front and on the sides of the test section for inserting a variety of probes, such as thermocouples, Pitot tubes, velocity measuring sensors, etc. Wind tunnel control is automated using ISD™ and stagePOINT™ technologies.



Automated temperature and velocity control

### Technical Data

- |                                 |   |
|---------------------------------|---|
| • <b>Length</b>                 | <b>78" (198 cm)</b>                       |
| • <b>Width</b>                  | <b>45" (114 cm)</b>                       |
| • <b>Height</b>                 | <b>112" (285 cm)</b>                      |
| • <b>Weight</b>                 | <b>2000 lbs. (900 kg)</b>                 |
| • <b>Flow range</b>             | <b>0 to 1,000 ft/min (5 m/s)</b>          |
| • <b>Power requirement</b>      | <b>230v single phase</b>                  |
| • <b>Control</b>                | <b>RS-232 with stagePOINT™ software</b>   |
| • <b>Temperature range</b>      | <b>-10°C to 85°C ± 1°C at temperature</b> |
| • <b>Velocity range</b>         | <b>0 - 5 m/s ± 2% at velocity</b>         |
| • <b>Number of sensor ports</b> | <b>24</b>                                 |



# CLWT-067

## BENCHTOP, CLOSED LOOP WIND TUNNEL FOR ELEVATED TEMPERATURE TESTING OF BOARDS AND COMPONENTS

The CLWT-067 is a research-quality closed loop wind tunnel that provides a convenient, accurate system for thermally characterizing PCBs and individual components at controlled temperatures from ambient to 85°C.

The CLWT-067 wind tunnel produces air flows up to 7.5 m/s (1500 ft/min). With customization, it can generate flows up to 50 m/s (10,000 ft/min) using orifice plates (available optionally). The clear Lexan test section lets the user to view the test specimen and allows for flow visualization.

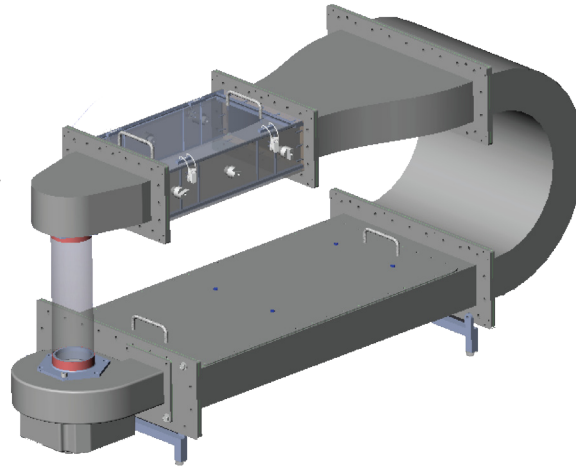

Unlike open loop wind tunnels, the CLWT-067 re-circulates internal air. This allows the system heater to quickly warm the air to a specific temperature. The testing of boards and components in hot air is a requirement in some NEBS and other standards. The precise controls and temperature range of the CLWT-067 wind tunnel allows its use for testing heat sink performance and for calibrating air and temperature sensors.

The complete wind tunnel fits on most lab benches and is powered from standard AC outlets. It has a smaller footprint than traditional, closed loop wind tunnels or environmental test chambers.

The wind tunnel's test section can be accessed from the top door for mounting and repositioning of boards, components and sensors. Internal rail guides provide an easy mechanism to install test specimens of different sizes (e.g., PCB, heat sink).

Instrument ports (6) are provided in the front and side walls of the test section for placing temperature and velocity sensors such as thermocouples, Pitot tubes and hot-wire anemometers.

Custom options are also available. Contact ATS for details.

\*RoHS Compliant

**OVERALL DIMENSIONS (L X W X H)**  
143.6 cm x 49.3 cm x 67.7 cm  
(56.5" x 19.4" x 26.6")

**TEST SECTION DIMENSIONS**  
41.8 cm x 22.5 cm x 9.5 cm  
(16.4" x 8.9" x 3.7")

**MATERIALS**  
ALUMINUM, PLEXIGLAS

**FLOW RANGE**  
0 TO 7.5 m/s (1500 ft/min)

**TEMPERATURE RANGE**  
Up to 85°C (185°F)

**WEIGHT**  
70.7 kg (156 lbs.)

### FEATURES:

- » **Quick Access**  
Quickly change the test specimen through the front access test section
- » **Sensor Ports**  
Measure pressure, velocity and temperature through the sensor ports
- » **Data Center**  
View data and monitor events (with optional controller)
- » **Flow Characteristics**  
High quality flow with very low turbulence intensity

### APPLICATIONS:

- » **High Temperature Testing**  
Evaluate the effects of elevated temperatures on component and PCB response and reliability
- » **Heat Sink Characterization**  
Characterize a variety of heat sink sizes for natural and forced convection cooling
- » **Sensor Calibration**  
Precision temperature and velocity controls allow accurate calibration of sensors
- » **Component Testing**  
Utilize for individual or multiple component testing
- » **Multiple PCB Testing**  
Test actual or simulated PCBs for thermal and flow distribution

For further technical information, please contact Advanced Thermal Solutions, Inc. at **1-781-769-2800** or **www.qats.com**

# CWT-108™

Unique Open Loop Wind Tunnel for Thermal Characterization of Components, Boards and Heat Sinks

The CWT-108™ is a research quality, open loop wind tunnel for thermal characterization of components, boards and heat sinks. It can produce uniform and homogeneous flow, up to 5 m/s (1000 ft/min) within the wind tunnel's test section due to its polynomial shape and internal flow management system, which features honeycombs and screens to break up turbulence.

The CWT-108™ can be operated vertically or horizontally and is made of aluminum and stainless steel with a see-through test section for ease of flow visualization.

The wind tunnel has an access door, conveniently located in the front of the test section for the mounting of boards and, optional internal rail guides that allow for the simple installation of different test specimens such as PCBs and heat sinks. In addition, there are 18 sensor ports in the front and on the sides of the test section for inserting a variety of probes, such as thermocouples, Pitot tubes, velocity measuring sensors, etc.

Each CWT-108™ fan tray is equipped with 24 volt-DC fans, which are individually controlled to generate airflow, and is fully compatible with ATS' WTC-100™ Wind Tunnel Controller that helps automate thermal characterization. ATS also carries a full line of temperature, flow and pressure sensors and scanners that are designed for use with the CWT-108™.

\* Power supply not included.

RECOMMENDED ACCESSORY: WTC-100



- » **WTC-100 Wind Tunnel Controller**
- » **ATVS-2020 Temperature & Velocity Scanner**
- » **Complete range of temperature and flow sensors**



#### OVERALL DIMENSIONS (L X W X H)

197.7 cm X 84.4 cm X 84.4 cm  
(77.84 X 33.39 X 33.39")

#### TEST SECTION

61.0 cm X 61.0 cm X 20.32 cm  
(24 X 24 X 7")

#### MATERIALS

ALUMINUM, PLEXIGLAS  
& STAINLESS STEEL

#### FLOW RANGE

0 TO 5 M/S (1000 FT/MIN)

#### WEIGHT

72.5 KG (160 LBS ) +/- 6%

For further technical information, please contact Advanced Thermal Solutions, Inc. at **781-769-2800** or **www.qats.com**.

**ATS** ADVANCED  
THERMAL  
SOLUTIONS, INC.  
Innovations in Thermal Management®



- » **Heat Sink Characterization**  
Characterize a variety of heat sink sizes for natural and forced convection cooling
- » **Heat Sink Comparison**  
Test two heat sinks side-by-side and compare their thermal performance in the same environment
- » **Component Testing**  
An ideal test vehicle for component characterization
- » **Multiple PCB Testing**  
Test actual or simulated PCBs for thermal and flow distribution
- » **Flow Visualization**  
Observe flow distribution in the tunnel by smoke or buoyant bubbles through the all Plexiglas® test section
- » **Variable Speed**  
Change flow rate by controlling the fan RPM
- » **Quick Access**  
Quickly change the test specimen through the front access test section
- » **Sensor Ports**  
Measure pressure, velocity and temperature through the sensor ports
- » **Data Center**  
View data and monitor events at the data center (with optional accessories)
- » **Flow Characteristics**  
High quality flow with very low turbulence intensity

RoHS Compliant

# CWT-107™

Unique Open Loop Wind Tunnel for Thermal Characterization of Components, Boards and Heat Sinks

The CWT-107™ is a research quality, open loop wind tunnel for thermal characterization of components, boards and heat sinks. It can produce uniform and homogeneous flow, up to 6 m/s (1200 ft/min) within the wind tunnel's test section due to its polynomial shape and internal flow management system, which features honeycombs and screens to break up turbulence.

The CWT-107™ can be operated vertically or horizontally and is made of aluminum and stainless steel with a see-through test section for ease of flow visualization.

The wind tunnel has an access door, conveniently located in the front of the test section for the mounting of boards and, optional internal rail guides that allow for the simple installation of different test specimens such as PCBs and heat sinks. In addition, there are 18 sensor ports in the front and on the sides of the test section for inserting a variety of probes, such as thermocouples, Pitot tubes, velocity measuring sensors, etc.

Each CWT-107™ fan tray is equipped with 24 volt-DC fans, which are individually controlled to generate airflow, and is fully compatible with ATS' WTC-100™ Wind Tunnel Controller that helps automate thermal characterization. ATS also carries a full line of temperature, flow and pressure sensors and scanners that are designed for use with the CWT-107™.

\* Power supply not included.

RECOMMENDED ACCESSORY: WTC-100



- » **WTC-100 Wind Tunnel Controller**
- » **ATVS-2020 Temperature & Velocity Scanner**
- » **Complete range of temperature and flow sensors**



**OVERALL DIMENSIONS (L X W X H)**  
197.7 cm X 76.2 cm X 101.6 cm  
(77.84 X 30 X 40")

**TEST SECTION**  
60.96 cm X 60.96 cm X 17.8 cm  
(24 X 24 X 7")

**MATERIALS**  
ALUMINUM, PLEXIGLAS  
& STAINLESS STEEL

**FLOW RANGE**  
0 TO 6 M/S (1200 FT/MIN)

**WEIGHT**  
53 kg (118 lbs.)

For further technical information, please contact Advanced Thermal Solutions, Inc. at **781-769-2800** or **www.qats.com**.



**ATS** ADVANCED  
THERMAL  
SOLUTIONS, INC.  
Innovations in Thermal Management®

- » **Heat Sink Characterization**  
Characterize a variety of heat sink sizes for natural and forced convection cooling
- » **Heat Sink Comparison**  
Test two heat sinks side-by-side and compare their thermal performance in the same environment
- » **Component Testing**  
An ideal test vehicle for component characterization
- » **Multiple PCB Testing**  
Test actual or simulated PCBs for thermal and flow distribution
- » **Flow Visualization**  
Observe flow distribution in the tunnel by smoke or buoyant bubbles through the all Plexiglas® test section
- » **Variable Speed**  
Change flow rate by controlling the fan RPM
- » **Quick Access**  
Quickly change the test specimen through the front access test section
- » **Sensor Ports**  
Measure pressure, velocity and temperature through the sensor ports
- » **Data Center**  
View data and monitor events at the data center (with optional accessories)
- » **Flow Characteristics**  
High quality flow with very low turbulence intensity

RoHS Compliant





Innovation in Thermal Management™

# CWT-106™

## Innovative Construction Allows You To Design Your Research Quality Wind Tunnels

### CWT-106™ Features

- **Customizable Research Quality Wind Tunnel**
- **Heat Sink Characterization**  
Characterize a variety of heat sink sizes for natural and forced convection cooling.
- **Heat Sink Comparison**  
Test two heat sinks side by side and compare their thermal performance in the same environment.
- **Component Testing**  
An ideal test vehicle for component characterization.
- **PCB Testing** Single or Multiple  
Test actual or simulated PCBs for thermal and flow distribution.
- **Flow Visualization**  
Observe flow distribution in the tunnel by smoke or buoyant bubbles through the all Plexiglas™ test section.
- **Variable Speed**  
Change flow rate by controlling the fan RPM.
- **Flow Direction**  
Test the effect of flow direction by controlling the fan operation.
- **Quick Access**  
Quickly change the test specimen through the front access test section.
- **Sensor Ports**  
Measure pressure, velocity and temperature through the sensor ports.
- **Data Center**  
View data and monitor events at the data center. (optional accessories not shown in the picture)
- **Flow Characteristics**  
High quality flow with very low turbulence intensity.

The CWT-106™ is a research quality wind tunnel designed for PCB and component level testing. It can be used for flow characterization, flow visualization and thermal resistance measurements. Air is drawn into the tunnel with variable DC fans mounted at the exhaust section of the tunnel. These fans are mounted on a tray and can be easily replaced with another tray to accommodate larger or smaller fans. The air velocity in the test section through the system can be varied from 0.5 m/s (100 ft/min) to 10 m/s (2000 ft/min). The wind tunnel has an internal flow management system, with honeycombs and screens to break up the turbulence and provide uniform and homogeneous flow in the test section.

The CWT-106™ can be operated both vertically and horizontally. The test section is made of Plexiglas™ for ease of flow visualization. There are 8 sensor ports in front and on the sides of the test section for inserting a variety of probes, such as thermocouples, Pitot tubes, velocity measuring sensors, etc. At the center of this plate, and flush with the surface, is a specially designed housing with a heat slug (optional) that can heat up the devices or heat sinks for thermal analysis (optimal accuracy). The flexibility of the movable plate and housing provides the users with a high degree of latitude to design and build their own setup to suit their needs.

### Technical Data

- Length: 84"
- Width: 17.75"
- Flow range: Up to 2,000 ft/min (10 m/s)
- Wall-to-Wall spacing: 6"
- Test plate: 17.75" x 17.50"
- Power required: Dependent on fan tray.
- Number of Sensor Ports: 18
- Depth: 8"
- Weight: 118 lbs.



WTC-100 Front View

### Accessories

- WTC-100™ Air Flow Controller.
- Heat Slug Single Plate: Dual element for side-by-side testing of components or heat sinks.\*
- Highly customizable for your application.

*\*Power supply not included*



# CWT-100™

## Controlled Wind Tunnel

The CWT-100™ is a research quality wind tunnel designed for PCB and component level testing. It can be used for flow characterization, flow visualization and thermal resistance measurements. Air is drawn into the tunnel with variable DC fans mounted at the exhaust section of the tunnel. These fans are mounted on a tray and can be easily replaced with another tray to accommodate larger or smaller fans. The air velocity in the test section through the system can be varied from 0.5 m/s (100 ft/min) to 10 m/s (2000 ft/min). The wind tunnel has an internal flow management system, with honeycombs and screens to break up the turbulence and provide uniform and homogeneous flow in the test section.

The CWT-100™ can be operated both vertically and horizontally. The test section is made of Plexiglas™ for ease of flow visualization. There are 12 sensor ports in front and on the sides of the test section for inserting a variety of probes, such as thermocouples, Pitot tubes, velocity measuring sensors, etc. At the center of this plate, and flush with the surface, is a specially designed housing with a heat slug (optional) that can heat up the devices or heat sinks for thermal analysis (optimal accuracy). The flexibility of the movable plate and housing allows users to design and build their own modifications to suit their needs. The CWT-100™ can be customized to your specific requirements.



Innovation in Thermal Management™

### CWT-100™ Features

- Heat Sink Characterization**  
 Characterize a variety of heat sink sizes for natural and forced convection cooling.
- Heat Sink Comparison**  
 Test two heat sinks side by side and compare their thermal performance in the same environment.
- Component Testing**  
 Test vehicle for component characterization.
- PCB Testing** Single or Multiple  
 Test actual or simulated PCBs for thermal and flow distribution.
- Flow Visualization**  
 Observe flow distribution in the tunnel by smoke or buoyant bubbles through the all Plexiglas™ test section.
- Variable Speed**  
 Change flow rate by controlling the fan RPM, using exterior power supply.
- Flow Direction**  
 Test the effect of flow direction by controlling the fan operation.
- Quick Access**  
 Quickly change the test specimen through the front access test section.
- Sensor Ports**  
 Measure pressure, velocity and temperature through the ports holes.
- Data Center**  
 View data and monitor events at the data center. (optional accessories not shown in the picture)
- Flow Characteristics**  
 High quality flow with very low turbulence intensity.

### Technical Data

- Length** 73" (185cm)
- Depth** 4" (10.26cm)
- Width** 17.75" (45cm)
- Weight** 60 lbs. (28 kg)
- Flow range** 0 to 1,200 ft/min (6 m/s)  
*Fans can be changed to attain higher speeds*
- Wall-to-wall spacing** 3¼" (8.5cm)  
*Can be custom designed for a specific application*
- Test plate** 13¼" x 11½" (34 x 29 cm)  
*Variable heat source*
- Power required** 24V DC at 1.5 Amps
- Number of Sensor Ports** 12

### Accessories

Heat-Slug Single Plate	HP-97-1	Single heating element for component/heat sink characterization*
Heat-Slug Dual Plate	HP-97-2	Dual heating element for side-by-side testing of component/heat sink characterization*
Data Center	MCS-1000	Manual controller for adjusting heaters & fans*
	PCS-1000	Programmable controller for automatic heat sink & component characterization*

\*Power supply not included

# BWT-104™

Benchtop, Research Quality Wind Tunnel



**ATS** ADVANCED  
THERMAL  
SOLUTIONS, INC.  
Innovations in Thermal Management®

The BWT-104™ is a research quality, open loop, benchtop wind tunnel for thermal characterization of components, circuit boards and cooling devices such as heat sinks, heat exchangers and cold plates. The polynomial shape and internal flow management system includes honeycombs and screens to break up turbulence and provides uniform, homogeneous flow, up to 6 m/s (1200 ft/min) within the test section. The BWT-104™ has 12 ports which allow a variety of probes, such as thermocouples, Pitot tubes, and temperature and velocity sensors, among others, to be inserted throughout the test section. The wind tunnel is made from aluminum and Plexiglas® and, provides a clear view of the test section for flow visualization. An access panel is conveniently located for mounting boards and, optional internal rail guides allow for simple installation of PCBs and heat sinks.

The BWT-104™ is 91 cm X 44 cm X 44 cm, (36 X 17.25 X 17.25"). It weighs only 14.5 kilograms (32 lbs.) and has the ability to operate on any axis, making it ideal for laboratory environments.

Each BWT-104™ fan tray is equipped with three 24-volt DC fans, which can be individually switched on and off, with an included control unit, to generate airflow. It is also available with ATS' WTC-100™ Wind Tunnel Controller, which helps automate thermal characterization, as an optional accessory. ATS also carries a full line of temperature, flow and pressure sensors and scanners that are designed for use with the BWT-104™.

\* Power supply not included.



#### OVERALL DIMENSIONS (L X W X H)

91 cm X 44 cm X 44 cm  
(36 X 17.25 X 17.25")

#### TEST SECTION DIMENSIONS

50.8 cm X 44 cm X 10 cm  
(20 X 17.25 X 4")

#### MATERIALS

ALUMINUM, PLEXIGLAS

#### FLOW RANGE

0 TO 6 M/S (1200 FT/MIN)

#### WEIGHT

14.5 kg (32 lbs.)

- » **Heat Sink Characterization**  
Characterize a variety of heat sink sizes for natural and forced convection cooling
- » **Heat Sink Comparison**  
Test two heat sinks side-by-side and compare their thermal performance in the same environment
- » **Component Testing**  
An ideal test vehicle for component characterization
- » **Multiple PCB Testing**  
Test actual or simulated PCBs for thermal and flow distribution
- » **Flow Visualization**  
Observe flow distribution in the tunnel by smoke or buoyant bubbles through the all Plexiglas® test section
- » **Variable Speed**  
Change flow rate by controlling the fan RPM
- » **Quick Access**  
Quickly change the test specimen through the front access test section
- » **Sensor Ports**  
Measure pressure, velocity and temperature through the sensor ports
- » **Data Center**  
View data and monitor events at the data center (with optional accessories)
- » **Flow Characteristics**  
High quality flow with very low turbulence intensity

RoHS Compliant

For further technical information, please contact Advanced Thermal Solutions, Inc. at **1-781-769-2800** or **www.qats.com**



Innovation in Thermal Management™

# BWT-100™

## Benchtop Wind Tunnel



### BWT-100™ Features

- Heat Sink Testing**  
 Characterize a variety of heat sink sizes for natural and forced convection cooling.
- Heat Sink Comparison**  
 Test two heat sinks side by side and compare their thermal performance in the same environment.
- Component Testing**  
 Test for component characterization.
- PCB Testing**  
 Test actual or simulated PCBs for thermal and flow distribution.
- Flow Visualization**  
 Observe flow distribution in the tunnel by smoke or buoyant bubbles through the all Plexiglas™ frame.
- Variable Speed**  
 Change flow rate by controlling the fan RPM.
- Flow Direction**  
 Test the effect of flow direction by controlling the fan operation.
- Quick Access**  
 Quickly change the test specimen through the rear access test board.
- Sensor Port**  
 Measure pressure, velocity and temperature through the ports at the entrance and exhaust of the test section.
- Data Center**  
 View data and monitor events at the data center
- Portable**  
 Truly portable tunnel that occupies little space and produces quality flow.

The BWT-100™ is a portable benchtop wind tunnel for thermal characterization of components, boards and heat sinks. The unit is made of Plexiglas™, weighs less than 8 pounds (4 kg) and produces flows up to 400 ft/min (2 m/s). It can be operated horizontally or vertically to adapt to direction-sensitive electronic cooling systems.

The BWT-100™ test section is rear accessed and accommodates a removable test plate for mounting of the test specimens. In another version of the test plate, insulated heat slugs are provided for heat sink characterization tests. Four small DC muffin fans can be individually controlled to generate the flow inside the BWT. The test section is flush-mounted to the base of the tunnel to eliminate any flow disturbances. Instrument ports are provided on the front panel of the unit for placement of temperature, velocity and pressure sensors. Sensors to measure the flow parameters are also supplied as optional accessories. The BWT-100™ can be customized to your specific requirements.

### Technical Data

- **Length** 22.75" (58cm)
- **Depth** 3" (7.5cm)
- **Width** 10.75" (27cm)
- **Weight** 8 lbs. (4 kg)
- **Flow range** 0 to 400 ft/min (2 m/s) *can be customized*
- **Wall-to-wall spacing** 1" (2.5 cm)
- **Test plate** 8½" x 10" (21.6 x 25.4cm)
- **Heat slug** 1¼" x 1¼" (3½ x 3½ cm)
- **Heat slug power dissipation** Up to 50W

### Accessories

Heat-Slug Single Plate	HP-97-1	Single heating element for component/heat sink characterization*
Heat-Slug Dual Plate	HP-97-2	Dual heating element for side-by-side testing of component/heat sink characterization*
Data Center	MCS-1000™	Manual controller for adjusting heaters & fans*
	PCS-1000™	Programmable controller for automatic heat sink & component characterization*

*\*Power supply not included*

Компания «Life Electronics» занимается поставками электронных компонентов импортного и отечественного производства от производителей и со складов крупных дистрибьюторов Европы, Америки и Азии.

С конца 2013 года компания активно расширяет линейку поставок компонентов по направлению коаксиальный кабель, кварцевые генераторы и конденсаторы (керамические, пленочные, электролитические), за счёт заключения дистрибьюторских договоров

Мы предлагаем:

- Конкурентоспособные цены и скидки постоянным клиентам.
- Специальные условия для постоянных клиентов.
- Подбор аналогов.
- Поставку компонентов в любых объемах, удовлетворяющих вашим потребностям.
- Приемлемые сроки поставки, возможна ускоренная поставка.
- Доставку товара в любую точку России и стран СНГ.
- Комплексную поставку.
- Работу по проектам и поставку образцов.
- Формирование склада под заказчика.
- Сертификаты соответствия на поставляемую продукцию (по желанию клиента).
- Тестирование поставляемой продукции.
- Поставку компонентов, требующих военную и космическую приемку.
- Входной контроль качества.
- Наличие сертификата ISO.

В составе нашей компании организован Конструкторский отдел, призванный помогать разработчикам, и инженерам.

Конструкторский отдел помогает осуществить:

- Регистрацию проекта у производителя компонентов.
- Техническую поддержку проекта.
- Защиту от снятия компонента с производства.
- Оценку стоимости проекта по компонентам.
- Изготовление тестовой платы монтаж и пусконаладочные работы.



Тел: +7 (812) 336 43 04 (многоканальный)

Email: [org@lifeelectronics.ru](mailto:org@lifeelectronics.ru)