

LOC		DIST		REVISIONS			
P	LTR	DATE	BY	APPV	REV	PER	ECO
D		14OCT10	PY	RL			10-020812

- THIS CONNECTOR ASSEMBLY IS SUPPLIED WITH METAL CONTACT RETENTION CLIPS INSTALLED IN THE INSERT ASSEMBLY.
- THIS CONNECTOR ASSEMBLY MEETS THE REQUIREMENTS OF LORAL SPEC 010772 AND MATES WITH ANY PLUG CONNECTOR WITH SAME INSERT ARRANGEMENT.
- MARK WITH .047 [1.19]-.062 [1.57] HIGH CHARACTERS. FAR SIDE REFERS TO THE WIDE SIDE OF THE KEYSTONE. NEAR SIDE REFERS TO THE NARROW SIDE OF THE KEYSTONE. IF THE REAR SHELL IS TOO SMALL FOR THE ENTIRE CUSTOMER PART NUMBER, MARKING SHALL BE LOCATED AS FOLLOWS:
 - CUSTOMER BASE NUMBER, ON FRONT SHELL, FAR SIDE.
 - CUSTOMER DASH NUMBER ON REAR SHELL, FAR SIDE.
 - "AMP" AND DATE CODE ON FRONT SHELL, NEAR SIDE.
 - AMP PART NUMBER ON REAR SHELL, NEAR SIDE.
- POINT OF ELECTRICAL ENGAGEMENT - AS MEASURED WITH A .039 [0.99] - .041 [1.04] DIAMETER SQUARE ENDED TEST PIN. CONTACT SHOWN INSTALLED FOR DIMENSIONAL REFERENCE ONLY.
- MAXIMUM WIRE INSULATION TO BE USED WITH THIS CONNECTOR ASSEMBLY IS .072 [1.83] DIAMETER.
- FOR CONTACT CRIMPING INSTRUCTION SHEET REFER TO AMP IS 7516. FOR CONTACT INSTALLATION AND REMOVAL INSTRUCTION SHEET REFER TO AMP IS 7508.
- DIMENSIONS AND TOLERANCES PER ANSI Y14.5M-1982.
- THIS DRAWING SHALL BE INTERPRETED IN ACCORDANCE WITH APPLICABLE STANDARDS LISTED IN MIL-STD-100.

PRELIMINARY-NOT RELEASED FOR PRODUCTION	.040 [1.02] .020 [0.51]	.432 [10.97] .412 [10.46]	1.093 [27.76] 1.073 [27.25]	.248 [6.30] .238 [6.05]	.439 [11.15] .419 [10.64]	.509 [12.93] .479 [12.17]	.316 [8.03] .306 [7.77]	1.317 [33.45] 1.307 [33.20]	.976 [24.79] .966 [24.54]	1.556 [39.52] 1.526 [38.76]	MS18274-1	15	2	B010772-0043	3-448816-2	3-448816-2
PRELIMINARY-NOT RELEASED FOR PRODUCTION	.049 [1.24] .029 [0.74]	.544 [13.82] .524 [13.31]	2.188 [55.58] 2.168 [55.07]			.620 [15.75] .590 [14.99]	.428 [10.87] .418 [10.62]	2.411 [61.24] 2.401 [60.99]	2.069 [52.55] 2.059 [52.30]	2.650 [67.31] 2.620 [66.55]	MS18277-1	50	5	B010772-0032	1-448816-5	1-448816-5
PRELIMINARY-NOT RELEASED FOR PRODUCTION			2.282 [57.96] 2.262 [57.45]	.248 [6.30] .238 [6.05]	.439 [11.15] .419 [10.64]			2.505 [63.63] 2.495 [63.37]	2.164 [54.97] 2.154 [54.71]	2.744 [69.70] 2.714 [68.94]	MS18276-1	37	4	B010772-0030	1-448816-4	1-448816-4
PRELIMINARY-NOT RELEASED FOR PRODUCTION	.040 [1.02] .020 [0.51]	.432 [10.97] .412 [10.46]	1.635 [41.53] 1.615 [41.02]	.248 [6.30] .238 [6.05]	.439 [11.15] .419 [10.64]	.509 [12.93] .479 [12.17]	.316 [8.03] .306 [7.77]	1.857 [47.17] 1.847 [46.91]	1.516 [38.51] 1.506 [38.25]	2.103 [53.42] 2.073 [52.65]	MS18275-1	25	3	B010772-0028	1-448816-3	1-448816-3
PRELIMINARY-NOT RELEASED FOR PRODUCTION			1.093 [27.76] 1.073 [27.25]					1.317 [33.45] 1.307 [33.20]	.976 [24.79] .966 [24.54]	1.556 [39.52] 1.526 [38.76]	MS18274-1	15	2	B010772-0026	1-448816-2	1-448816-2
			.769 [19.53] .749 [19.02]					.989 [25.12] .979 [24.87]	.648 [16.46] .638 [16.21]	1.228 [31.19] 1.198 [30.43]	MS18273-1	9	1	B010772-0024	1-448816-1	1-448816-1
	.049 [1.24] .029 [0.74]	.544 [13.82] .524 [13.31]	2.188 [55.58] 2.168 [55.07]			.620 [15.75] .590 [14.99]	.428 [10.87] .418 [10.62]	2.411 [61.24] 2.401 [60.99]	2.069 [52.55] 2.059 [52.30]	2.650 [67.31] 2.620 [66.55]	MS18277-1	50	5	A010772-0010	1-448816-0	1-448816-0
			2.282 [57.96] 2.262 [57.45]	.248 [6.30] .238 [6.05]	.439 [11.15] .419 [10.64]			2.505 [63.63] 2.495 [63.37]	2.164 [54.97] 2.154 [54.71]	2.744 [69.70] 2.714 [68.94]	MS18276-1	37	4	A010772-0008	448816-9	448816-9
		.432 [10.97] .412 [10.46]	1.635 [41.53] 1.615 [41.02]	.248 [6.30] .238 [6.05]	.439 [11.15] .419 [10.64]	.509 [12.93] .479 [12.17]	.316 [8.03] .306 [7.77]	1.857 [47.17] 1.847 [46.91]	1.516 [38.51] 1.506 [38.25]	2.103 [53.42] 2.073 [52.65]	MS18275-1	25	3	A010772-0006	448816-8	448816-8
	.040 [1.02] .020 [0.51]		1.093 [27.76] 1.073 [27.25]					1.317 [33.45] 1.307 [33.20]	.976 [24.79] .966 [24.54]	1.556 [39.52] 1.526 [38.76]	MS18274-1	15	2	A010772-0004	448816-7	448816-7
			.769 [19.53] .749 [19.02]					.989 [25.12] .979 [24.87]	.648 [16.46] .638 [16.21]	1.228 [31.19] 1.198 [30.43]	MS18273-1	9	1	A010772-0002	448816-6	448816-6
	.049 [1.24] .029 [0.74]	.544 [13.82] .524 [13.31]	2.188 [55.58] 2.168 [55.07]			.620 [15.75] .590 [14.99]	.428 [10.87] .418 [10.62]	2.411 [61.24] 2.401 [60.99]	2.069 [52.55] 2.059 [52.30]	2.650 [67.31] 2.620 [66.55]	MS18277-1	50	5	B010772-0010	448816-5	448816-5
			2.282 [57.96] 2.262 [57.45]	.248 [6.30] .238 [6.05]	.439 [11.15] .419 [10.64]			2.505 [63.63] 2.495 [63.37]	2.164 [54.97] 2.154 [54.71]	2.744 [69.70] 2.714 [68.94]	MS18276-1	37	4	B010772-0008	448816-4	448816-4
		.432 [10.97] .412 [10.46]	1.635 [41.53] 1.615 [41.02]	.248 [6.30] .238 [6.05]	.439 [11.15] .419 [10.64]	.509 [12.93] .479 [12.17]	.316 [8.03] .306 [7.77]	1.857 [47.17] 1.847 [46.91]	1.516 [38.51] 1.506 [38.25]	2.103 [53.42] 2.073 [52.65]	MS18275-1	25	3	B010772-0006	448816-3	448816-3
	.040 [1.02] .020 [0.51]		1.093 [27.76] 1.073 [27.25]					1.317 [33.45] 1.307 [33.20]	.976 [24.79] .966 [24.54]	1.556 [39.52] 1.526 [38.76]	MS18274-1	15	2	B010772-0004	448816-2	448816-2
			.769 [19.53] .749 [19.02]					.989 [25.12] .979 [24.87]	.648 [16.46] .638 [16.21]	1.228 [31.19] 1.198 [30.43]	MS18273-1	9	1	B010772-0002	448816-1	448816-1
L	J	H	G	F	E	D	C	B	A		INSERT ARRANGEMENT	NO OF POS	SHELL SIZE	CUSTOMER P/N ON CONNECTOR	AMP P/N ON CONNECTOR	PART NUMBER

THIS DRAWING IS A CONTROLLED DOCUMENT.

DIMENSIONS: INCHES	TOLERANCES UNLESS OTHERWISE SPECIFIED:	0 PLC ± .005	1 PLC ± .005	2 PLC ± .005	3 PLC ± .005	4 PLC ± .005	ANGLES ± .1°
--------------------	--	--------------	--------------	--------------	--------------	--------------	--------------

MATERIAL: SEE CALLOUTS FINISH: SEE CALLOUTS

WEIGHT: —

CUSTOMER DRAWING

APPROVED: F. KINSEY

DATE: 2-17-93

NAME: AMPLIMITE NONMAGNETIC RECEPTACLE ASSY WITH SIZE 20 CRIMP TYPE SOCKET CONTACTS SERIES 109, SHELL SIZES 1 THRU 5

SIZE: A1

SCALE: 4:1

SHEET: 1 OF 2

REV: D

LOC		DIST		REVISIONS			
DF	DO	P	LTR	DESCRIPTION	DATE	DNW	APVD
-	-	-	-	SEE SHEET 1	-	-	-

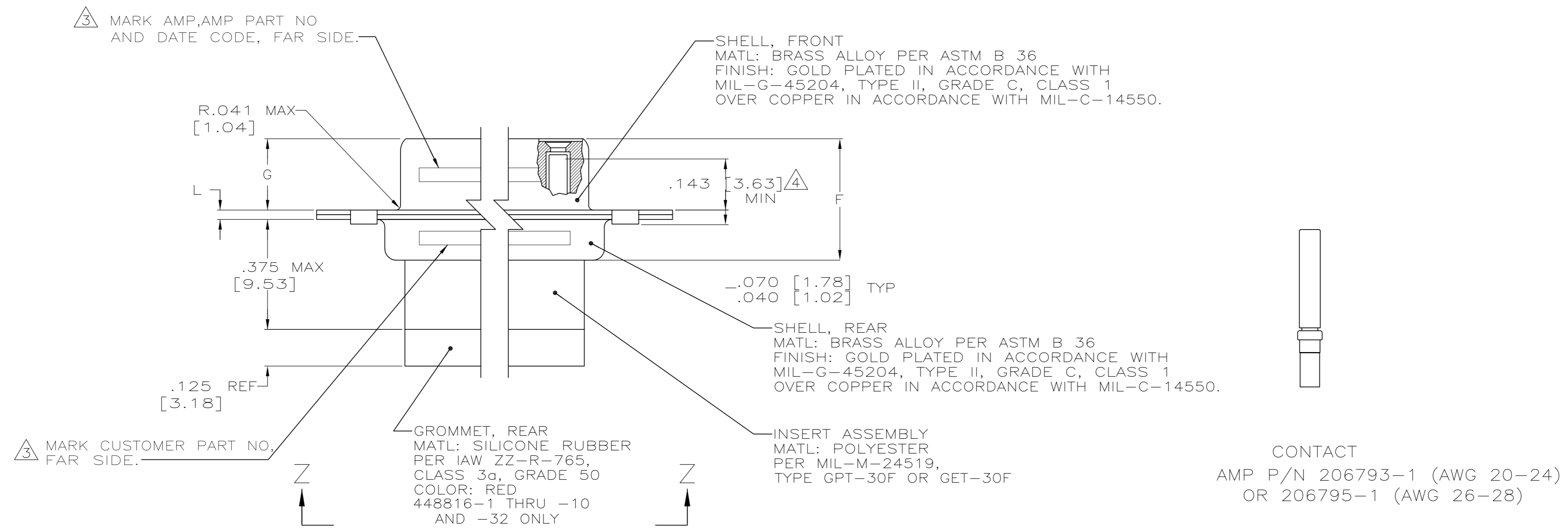
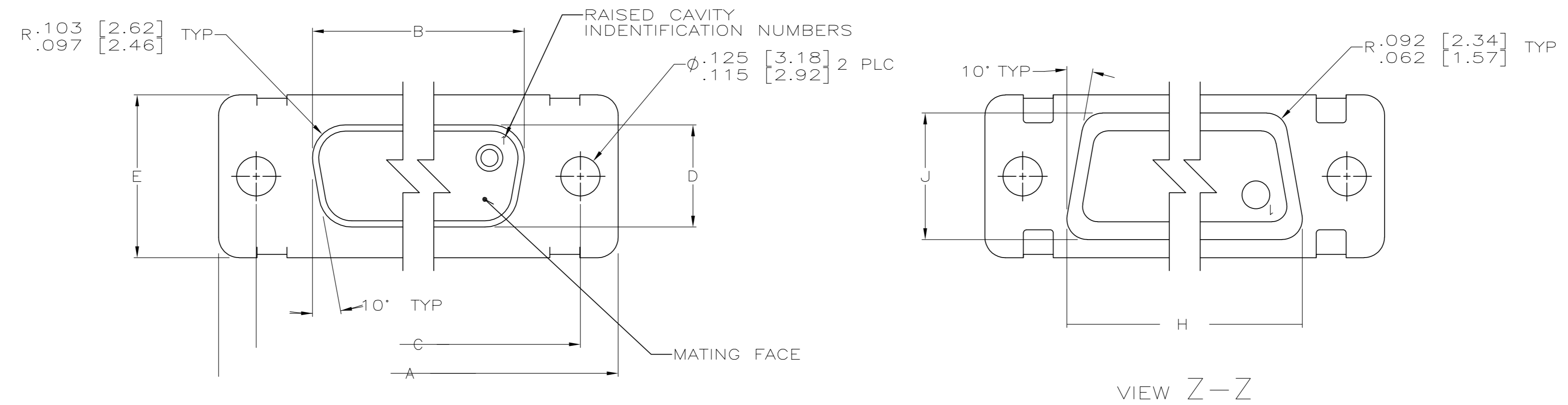

THIS DRAWING IS A CONTROLLED DOCUMENT.		DWN AJ GRAFF 2-11-93	Tyco Electronics Corporation Harrisburg, PA 17105-3608	
DIMENSIONS: INCHES		CHK F. KINSEY 2-17-93	Tyco Electronics	
TOLERANCES UNLESS OTHERWISE SPECIFIED:		APVD -	NAME -	
0 PLC ± -		PRODUCT SPEC MIL-C-24308		
1 PLC ± -		APPLICATION SPEC -		
2 PLC ± -		SIZE A1		
3 PLC ± -		CAGE CODE 00779		
4 PLC ± -		DRAWING NO 448816		
ANGLES ± ± -		RESTRICTED TO -		
MATERIAL SEE CALLOUTS		FINISH SEE CALLOUTS		SCALE 4:1 SHEET 2 OF 2 REV D
CUSTOMER DRAWING		-		

Компания «Life Electronics» занимается поставками электронных компонентов импортного и отечественного производства от производителей и со складов крупных дистрибьюторов Европы, Америки и Азии.

С конца 2013 года компания активно расширяет линейку поставок компонентов по направлению коаксиальный кабель, кварцевые генераторы и конденсаторы (керамические, пленочные, электролитические), за счёт заключения дистрибьюторских договоров

Мы предлагаем:

- Конкуренеспособные цены и скидки постоянным клиентам.
- Специальные условия для постоянных клиентов.
- Подбор аналогов.
- Поставку компонентов в любых объемах, удовлетворяющих вашим потребностям.
- Приемлемые сроки поставки, возможна ускоренная поставка.
- Доставку товара в любую точку России и стран СНГ.
- Комплексную поставку.
- Работу по проектам и поставку образцов.
- Формирование склада под заказчика.
- Сертификаты соответствия на поставляемую продукцию (по желанию клиента).
- Тестирование поставляемой продукции.
- Поставку компонентов, требующих военную и космическую приемку.
- Входной контроль качества.
- Наличие сертификата ISO.

В составе нашей компании организован Конструкторский отдел, призванный помогать разработчикам, и инженерам.

Конструкторский отдел помогает осуществить:

- Регистрацию проекта у производителя компонентов.
- Техническую поддержку проекта.
- Защиту от снятия компонента с производства.
- Оценку стоимости проекта по компонентам.
- Изготовление тестовой платы монтаж и пусконаладочные работы.



Тел: +7 (812) 336 43 04 (многоканальный)

Email: org@lifeelectronics.ru