

N-channel 525 V, 0.72 Ω typ., 6 A, MDmesh™ K3 Power MOSFETs in DPAK and TO-220 packages

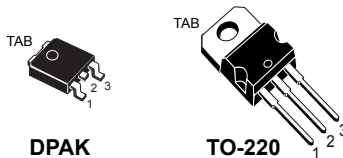

DPAK

TO-220

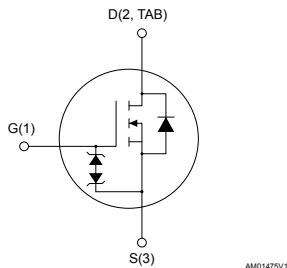

AM01475V1

Features

Order codes	V_{DS}	$R_{DS(on)}$ max.	I_D	P_{TOT}
STD7N52K3	525 V	0.85 Ω	6 A	90 W
STP7N52K3				

- 100% avalanche tested
- Extremely high dv/dt capability
- Very low intrinsic capacitance
- Improved diode reverse recovery characteristics
- Zener-protected

Applications

- Switching applications

Description

These MDmesh™ K3 Power MOSFETs are the result of improvements applied to STMicroelectronics' MDmesh™ technology, combined with a new optimized vertical structure. These devices boast an extremely low on-resistance, superior dynamic performance and high avalanche capability, rendering them suitable for the most demanding applications.

Product status links

[STD7N52K3](#)
[STP7N52K3](#)

Product summary

STD7N52K3

Order code	STD7N52K3
-------------------	-----------

Marking	7N52K3
----------------	--------

Package	DPAK
----------------	------

Packing	Tape and reel
----------------	---------------

STP7N52K3

Order code	STP7N52K3
-------------------	-----------

Marking	7N52K3
----------------	--------

Package	TO-220
----------------	--------

Packing	Tube
----------------	------

1 Electrical ratings

Table 1. Absolute maximum ratings

Symbol	Parameter	Value	Unit
V_{GS}	Gate-source voltage	±30	V
I_D	Drain current (continuous) at $T_C = 25\text{ °C}$	6	A
	Drain current (continuous) at $T_C = 100\text{ °C}$	3.8	A
$I_{DM}^{(1)}$	Drain current (pulsed)	24	A
P_{TOT}	Total dissipation at $T_C = 25\text{ °C}$	90	W
$I_{AR}^{(2)}$	Avalanche current, repetitive or non-repetitive	3	A
$E_{AS}^{(3)}$	Single pulse avalanche energy	100	mJ
ESD	Gate-source human body model (C = 100 pF, R = 1.5 kΩ)	2.5	kV
$dv/dt^{(4)}$	Peak diode recovery voltage slope	12	V/ns
T_{stg}	Storage temperature range	-55 to 150	°C
T_J	Operating junction temperature range		

1. Pulse width is limited by safe operating area.
2. Pulse width is limited by T_{Jmax} .
3. Starting $T_J = 25\text{ °C}$, $I_D = I_{AR}$, $V_{DD} = 50\text{ V}$
4. $I_{SD} \leq 6\text{ A}$, $di/dt \leq 400\text{ A}/\mu\text{s}$, $V_{DS(peak)} < V_{(BR)DSS}$, $V_{DD} = 80\% V_{(BR)DSS}$

Table 2. Thermal data

Symbol	Parameter	Value		Unit
		DPAK	TO-220	
$R_{thj-case}$	Thermal resistance junction-case	1.39		°C/W
$R_{thj-pcb}^{(1)}$	Thermal resistance junction-pcb	50		°C/W
$R_{thj-amb}$	Thermal resistance junction-ambient		62.5	°C/W

1. When mounted on an 1-inch² FR-4, 2oz Cu board.

2 Electrical characteristics

($T_C = 25\text{ °C}$ unless otherwise specified)

Table 3. On/off states

Symbol	Parameter	Test conditions	Min.	Typ.	Max.	Unit
$V_{(BR)DSS}$	Drain-source breakdown voltage	$I_D = 1\text{ mA}$, $V_{GS} = 0\text{ V}$	525			V
I_{DSS}	Zero gate voltage drain current	$V_{GS} = 0\text{ V}$, $V_{DS} = 525\text{ V}$			1	μA
		$V_{GS} = 0\text{ V}$, $V_{DS} = 525\text{ V}$, $T_C = 125\text{ °C}^{(1)}$			50	μA
I_{GSS}	Gate body leakage current	$V_{GS} = \pm 20\text{ V}$, $V_{DS} = 0\text{ V}$			± 10	μA
$V_{GS(th)}$	Gate threshold voltage	$V_{DS} = V_{GS}$, $I_D = 50\text{ }\mu\text{A}$	3	3.75	4.5	V
$R_{DS(on)}$	Static drain-source on-resistance	$V_{GS} = 10\text{ V}$, $I_D = 3\text{ A}$		0.72	0.85	Ω

1. Defined by design, not subject to production test.

Table 4. Dynamic

Symbol	Parameter	Test conditions	Min.	Typ.	Max.	Unit
C_{iss}	Input capacitance	$V_{DS} = 50\text{ V}$, $f = 1\text{ MHz}$, $V_{GS} = 0\text{ V}$	-	870	-	pF
C_{oss}	Output capacitance			70		
C_{rss}	Reverse transfer capacitance			13		
$C_{oss(tr)}^{(1)}$	Equivalent output capacitance	$V_{DS} = 0\text{ to }420\text{ V}$, $V_{GS} = 0\text{ V}$,	-	53	-	pF
R_G	Intrinsic gate resistance	$f = 1\text{ MHz}$ open drain	-	3.5	-	Ω
Q_g	Total gate charge	$V_{DD} = 420\text{ V}$, $I_D = 6\text{ A}$, $V_{GS} = 0\text{ to }10\text{ V}$ (see Figure 17. Test circuit for gate charge behavior)	-	33	-	nC
Q_{gs}	Gate-source charge			6		
Q_{gd}	Gate-drain charge			21		

1. $C_{oss(tr)}$ is defined as the constant equivalent capacitance giving the same storage energy as C_{oss} when V_{DS} increases from 0 to 420 V.

Table 5. Switching times

Symbol	Parameter	Test conditions	Min.	Typ.	Max.	Unit
$t_{d(on)}$	Turn-on delay time	$V_{DD} = 260\text{ V}$, $I_D = 3\text{ A}$, $R_G = 4.7\text{ }\Omega$, $V_{GS} = 10\text{ V}$ (see Figure 16. Test circuit for resistive load switching times and Figure 21. Switching time waveform)	-	13	-	ns
t_r	Rise time			11		
$t_{d(off)}$	Turn-off delay time			36		
t_f	Fall time			19		

Table 6. Source-drain diode

Symbol	Parameter	Test conditions	Min.	Typ.	Max.	Unit	
I_{SD}	Source-drain current		-		6	A	
$I_{SDM}^{(1)}$	Source-drain current (pulsed)				24		
$V_{SD}^{(2)}$	Forward on voltage	$I_{SD} = 6\text{ A}$, $V_{GS} = 0\text{ V}$	-		1.5	V	
t_{rr}	Reverse recovery time	$I_{SD} = 6\text{ A}$, $di/dt = 100\text{ A}/\mu\text{s}$, $V_{DD} = 60\text{ V}$ (see Figure 18. Test circuit for inductive load switching and diode recovery times)	-	220		ns	
Q_{rr}	Reverse recovery charge			1.8			μC
I_{RRM}	Reverse recovery current			16			
t_{rr}	Reverse recovery time	$I_{SD} = 6\text{ A}$, $di/dt = 100\text{ A}/\mu\text{s}$, $V_{DD} = 60\text{ V}$, $T_j = 150\text{ °C}$ (see Figure 18. Test circuit for inductive load switching and diode recovery times)	-	250		ns	
Q_{rr}	Reverse recovery charge			2.2			μC
I_{RRM}	Reverse recovery current			18			

1. Pulse width limited by safe operating area.
2. Pulsed: pulse duration = 300 μs, duty cycle 1.5%.

Table 7. Gate-source Zener diode

Symbol	Parameter	Test conditions	Min.	Typ.	Max.	Unit
$V_{(BR)GSO}$	Gate-source breakdown voltage	$I_{GS} = \pm 1\text{ mA}$, $I_D = 0\text{ A}$	30	-	-	V

The built-in back-to-back Zener diodes are specifically designed to enhance the ESD performance of the device. The Zener voltage facilitates efficient and cost-effective device integrity protection, thus eliminating the need for additional external componentry.

2.1 Electrical characteristics (curves)

Figure 1. Safe operating area for DPAK

Figure 2. Thermal impedance for DPAK

Figure 3. Safe operating area for TO-220

Figure 4. Thermal impedance for TO-220

Figure 5. Output characteristics

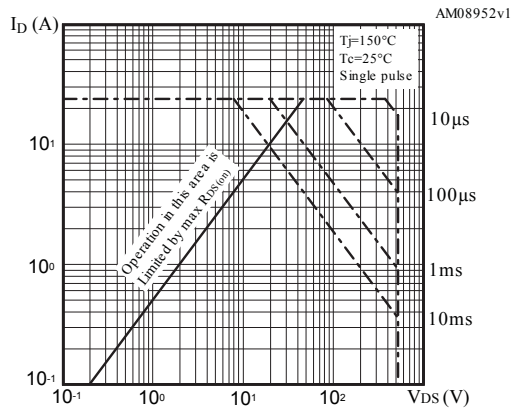
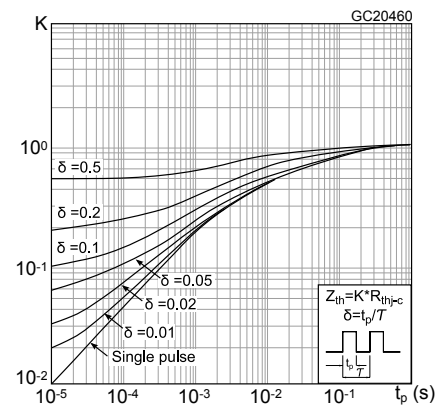
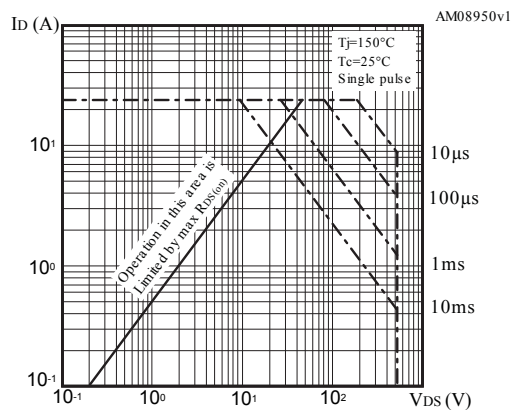
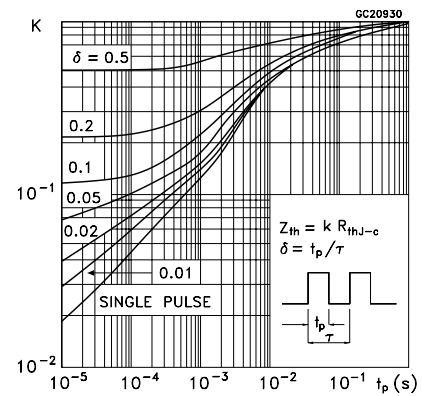
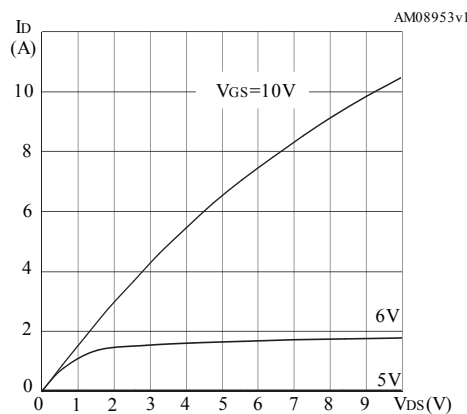
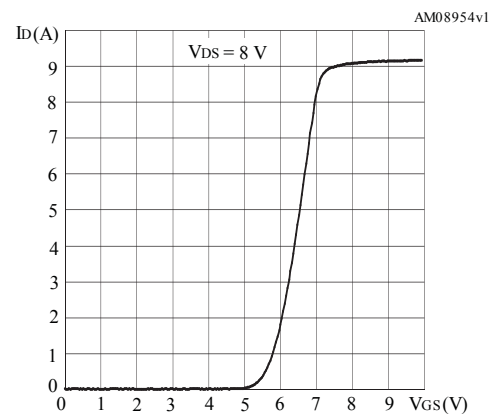
Figure 6. Transfer characteristics

Figure 7. Normalized $V_{(BR)DSS}$ vs temperature

Figure 8. Static drain-source on-resistance

Figure 9. Output capacitance stored energy

Figure 10. Capacitance variations

Figure 11. Gate charge vs gate-source voltage

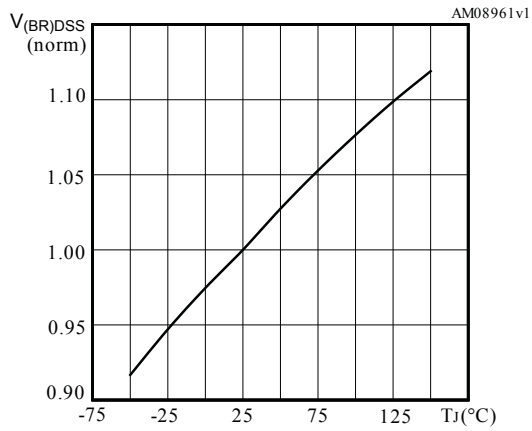
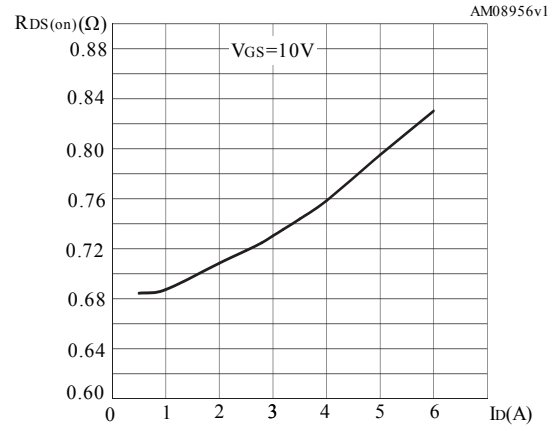
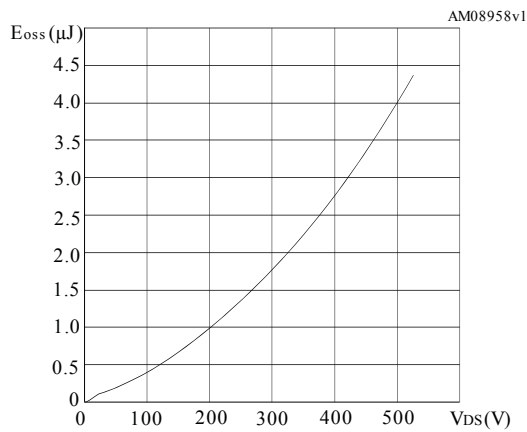
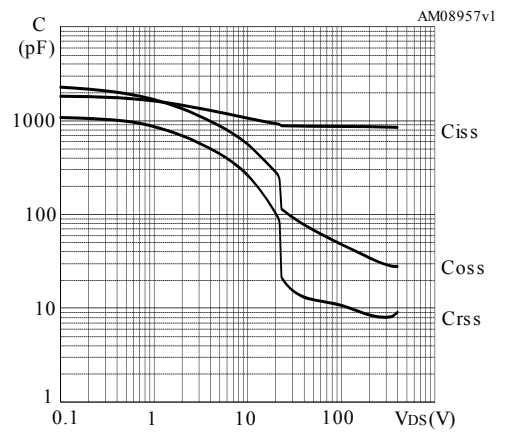
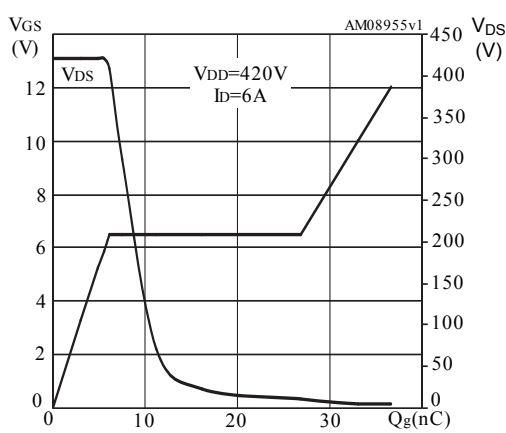
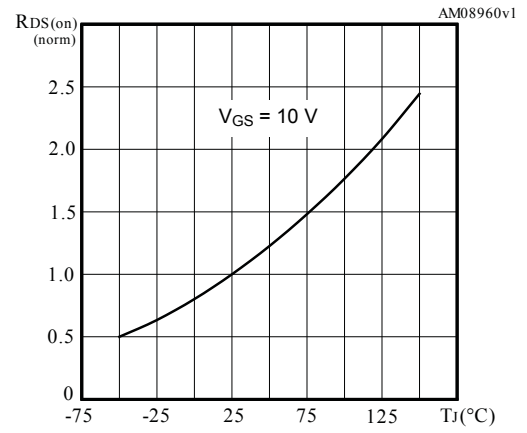
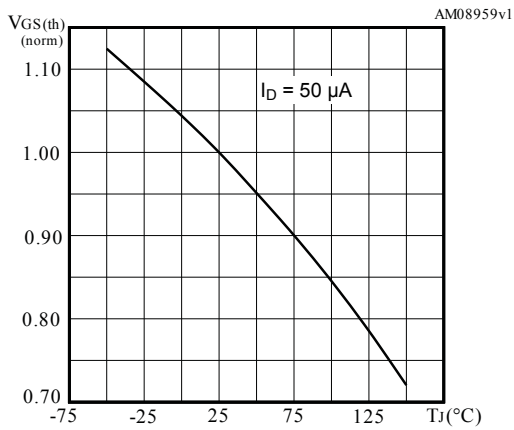
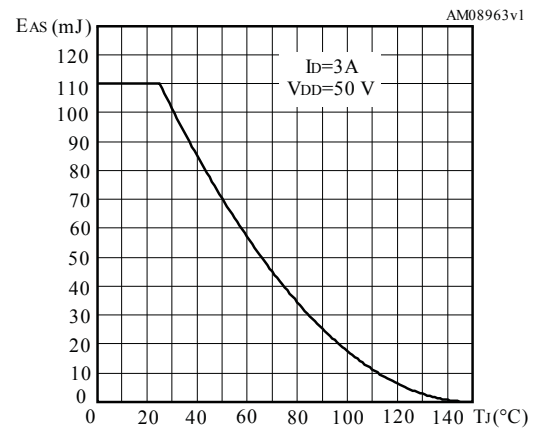
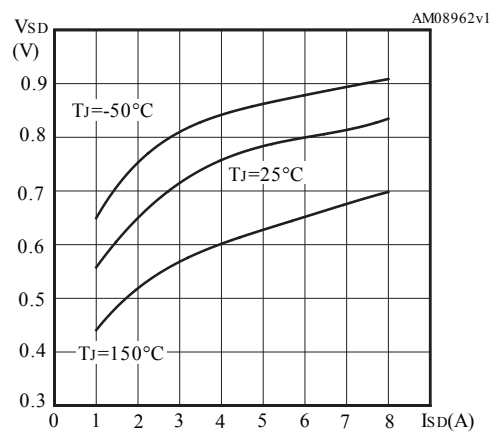
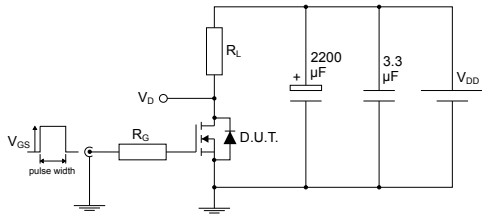
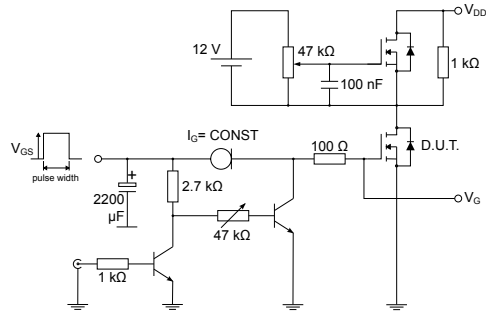
Figure 12. Normalized on-resistance vs temperature

Figure 13. Normalized gate threshold voltage vs temperature

Figure 14. Maximum avalanche energy vs temperature

Figure 15. Source-drain diode forward characteristics

3 Test circuits

Figure 16. Test circuit for resistive load switching times

AM01468v1

Figure 17. Test circuit for gate charge behavior

AM01469v1

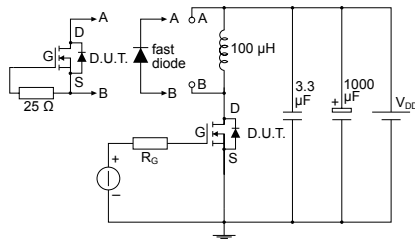
Figure 18. Test circuit for inductive load switching and diode recovery times

AM01470v1

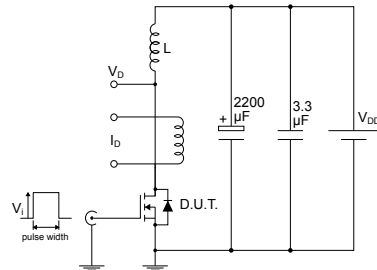
Figure 19. Unclamped inductive load test circuit

AM01471v1

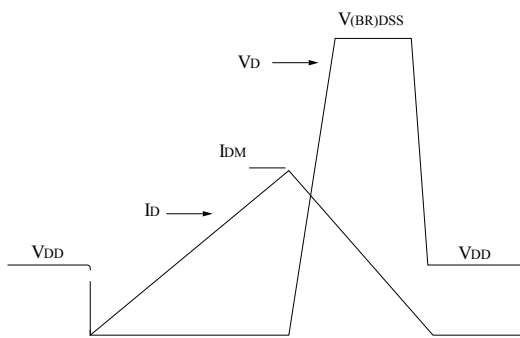
Figure 20. Unclamped inductive waveform

AM01472v1

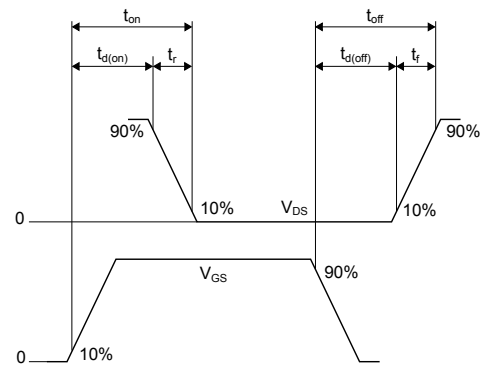
Figure 21. Switching time waveform

AM01473v1

4 Package information

In order to meet environmental requirements, ST offers these devices in different grades of ECOPACK® packages, depending on their level of environmental compliance. ECOPACK® specifications, grade definitions and product status are available at: www.st.com. ECOPACK® is an ST trademark.

4.1 DPAK (TO-252) type A2 package information

Figure 22. DPAK (TO-252) type A2 package outline

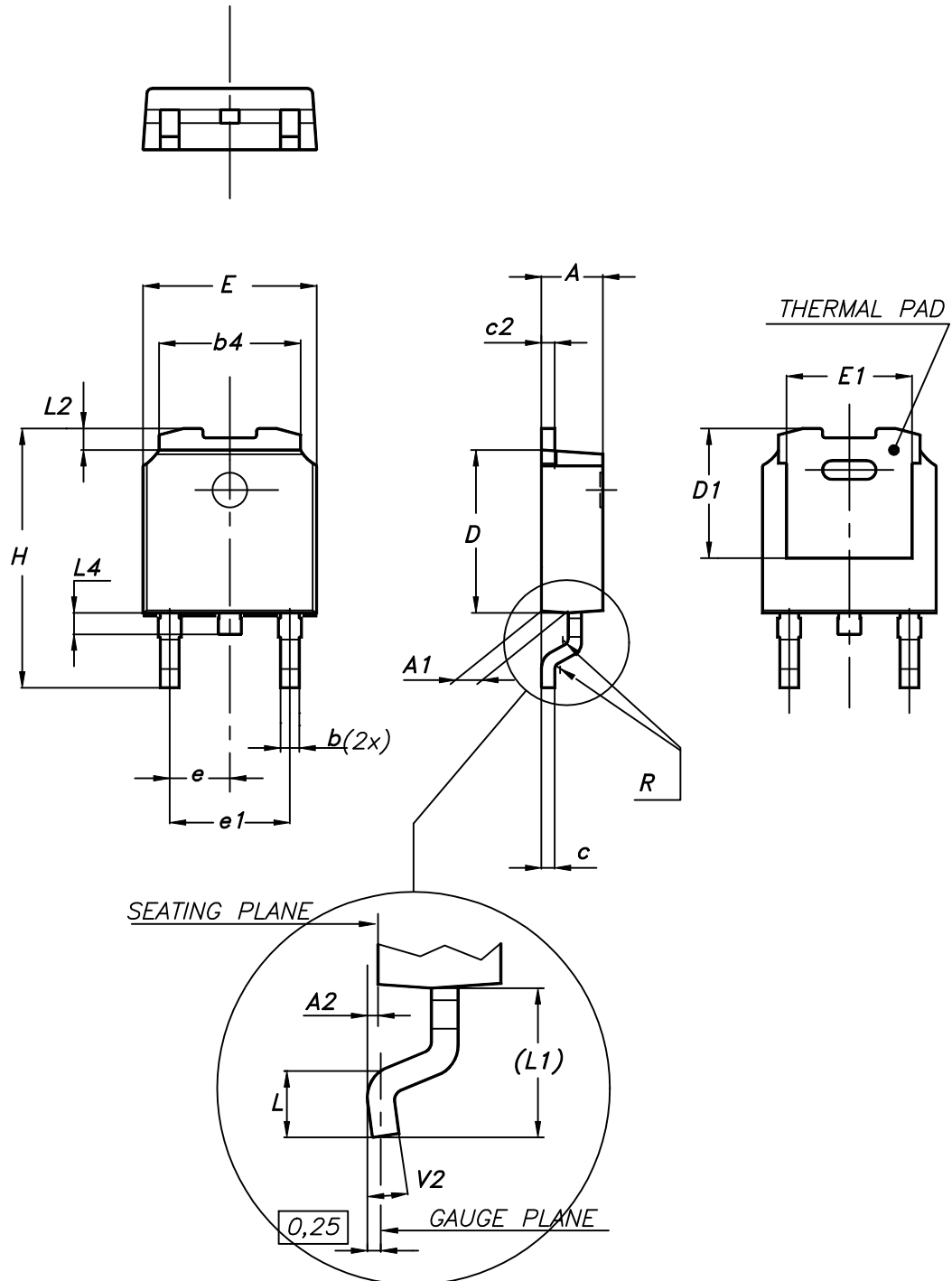

0068772_type-A2_rev25

Table 8. DPAK (TO-252) type A2 mechanical data

Dim.	mm		
	Min.	Typ.	Max.
A	2.20		2.40
A1	0.90		1.10
A2	0.03		0.23
b	0.64		0.90
b4	5.20		5.40
c	0.45		0.60
c2	0.48		0.60
D	6.00		6.20
D1	4.95	5.10	5.25
E	6.40		6.60
E1	5.10	5.20	5.30
e	2.159	2.286	2.413
e1	4.445	4.572	4.699
H	9.35		10.10
L	1.00		1.50
L1	2.60	2.80	3.00
L2	0.65	0.80	0.95
L4	0.60		1.00
R		0.20	
V2	0°		8°

4.2 DPAK (TO-252) type C2 package information

Figure 23. DPAK (TO-252) type C2 package outline

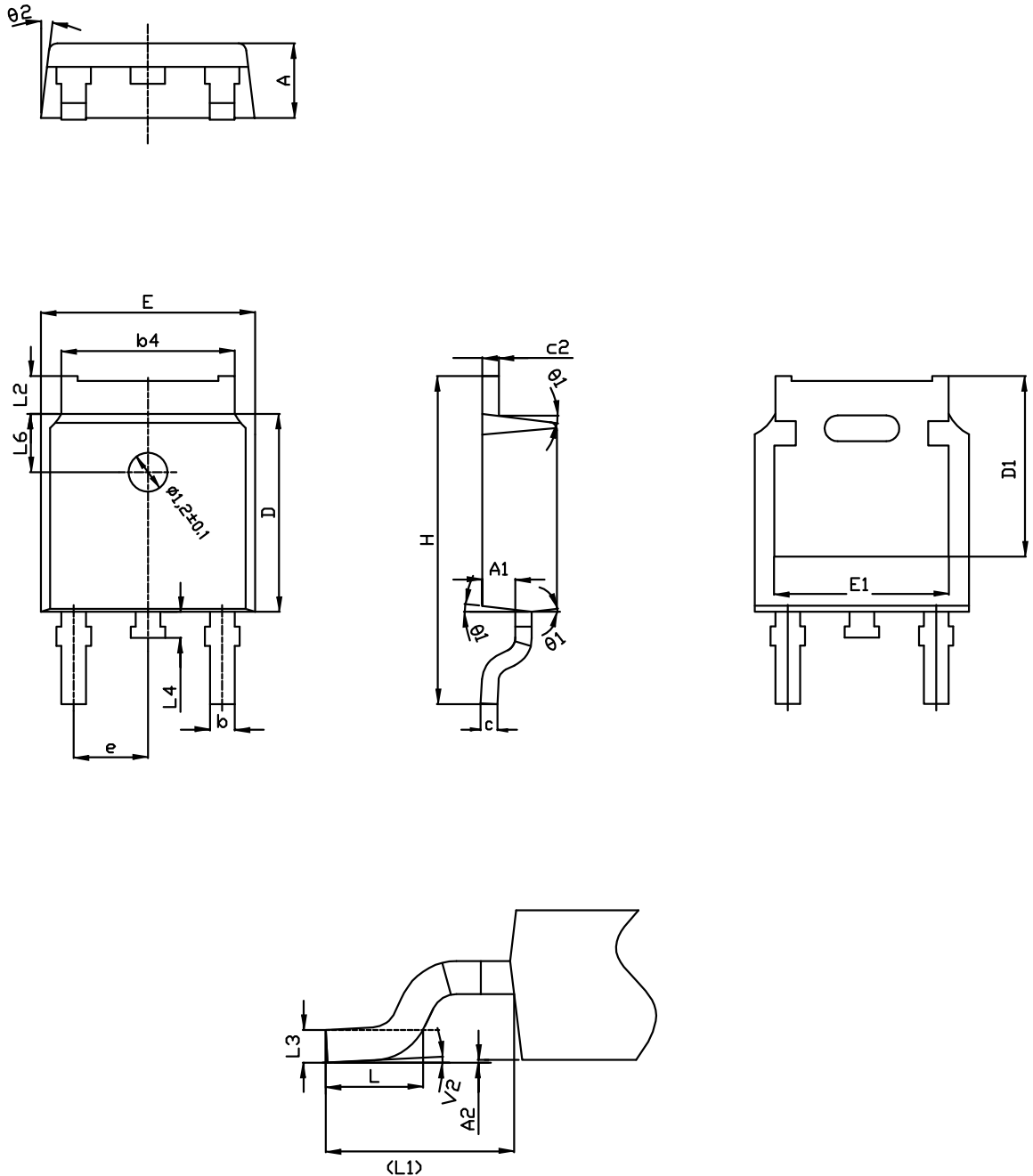

0068772_C2_25

Table 9. DPAK (TO-252) type C2 mechanical data

Dim.	mm		
	Min.	Typ.	Max.
A	2.20	2.30	2.38
A1	0.90	1.01	1.10
A2	0.00		0.10
b	0.72		0.85
b4	5.13	5.33	5.46
c	0.47		0.60
c2	0.47		0.60
D	6.00	6.10	6.20
D1	5.10		5.60
E	6.50	6.60	6.70
E1	5.20		5.50
e	2.186	2.286	2.386
H	9.80	10.10	10.40
L	1.40	1.50	1.70
L1	2.90 REF		
L2	0.90		1.25
L3	0.51 BSC		
L4	0.60	0.80	1.00
L6	1.80 BSC		
θ1	5°	7°	9°
θ2	5°	7°	9°
V2	0°		8°

Figure 24. DPAK (TO-252) recommended footprint (dimensions are in mm)

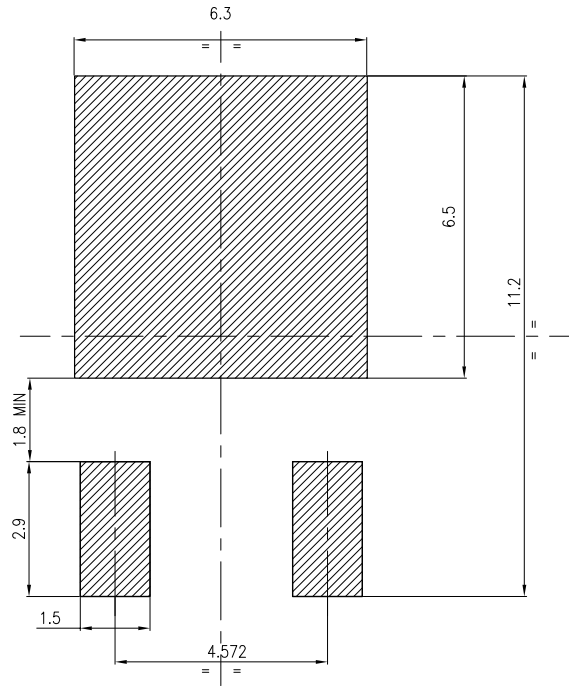

FP_0068772_25

4.3 DPAK (TO-252) packing information

Figure 25. DPAK (TO-252) tape outline

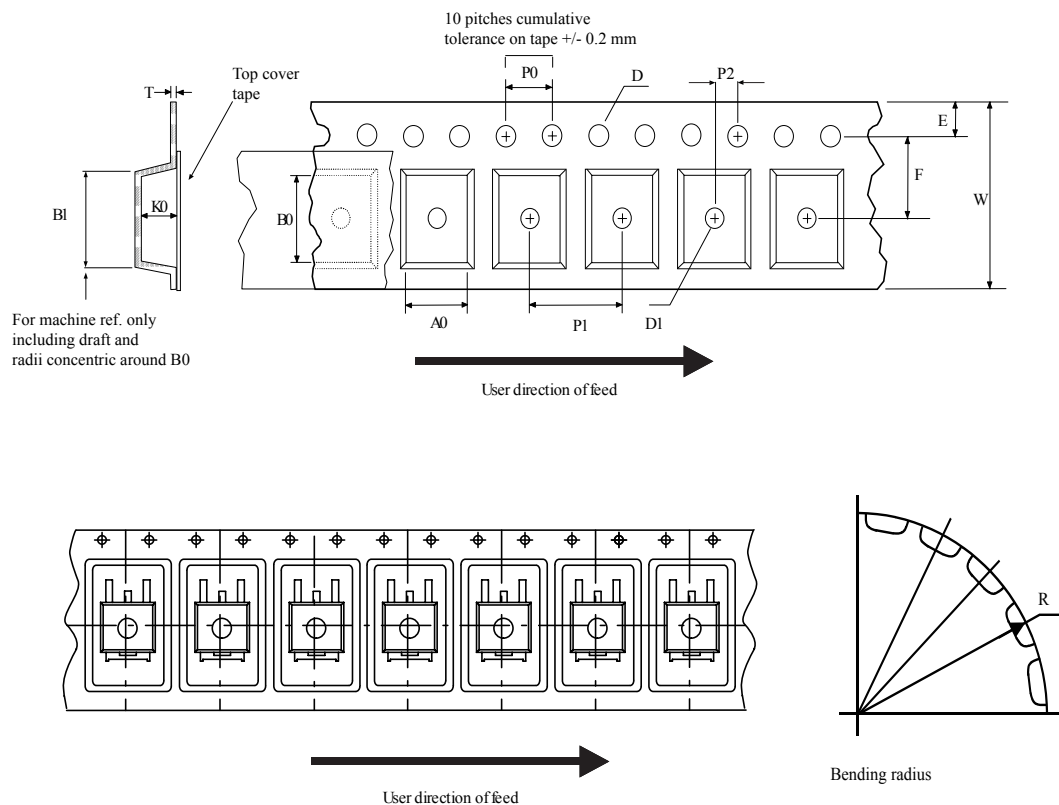

AM08852v1

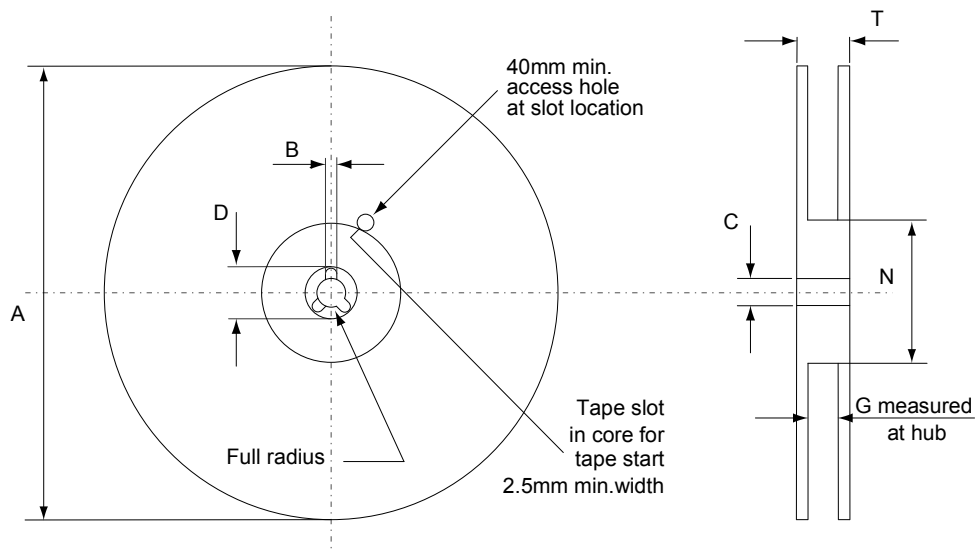
Figure 26. DPAK (TO-252) reel outline

AM06038v1

Table 10. DPAK (TO-252) tape and reel mechanical data

Tape			Reel		
Dim.	mm		Dim.	mm	
	Min.	Max.		Min.	Max.
A0	6.8	7	A		330
B0	10.4	10.6	B	1.5	
B1		12.1	C	12.8	13.2
D	1.5	1.6	D	20.2	
D1	1.5		G	16.4	18.4
E	1.65	1.85	N	50	
F	7.4	7.6	T		22.4
K0	2.55	2.75			
P0	3.9	4.1	Base qty.		2500
P1	7.9	8.1	Bulk qty.		2500
P2	1.9	2.1			
R	40				
T	0.25	0.35			
W	15.7	16.3			

4.4 TO-220 type A package information

Figure 27. TO-220 type A package outline

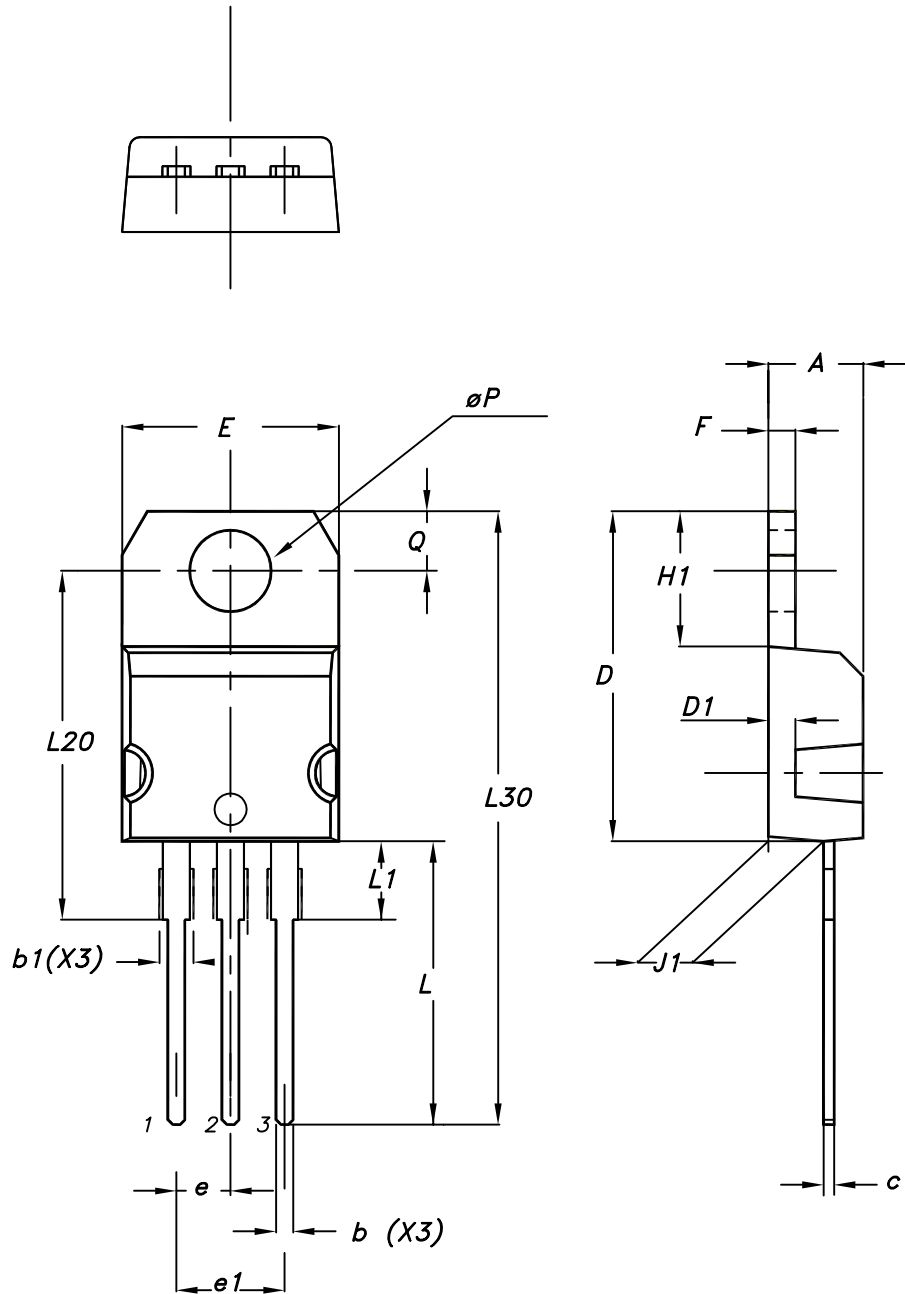

0015988_typeA_Rev_21

Table 11. TO-220 type A package mechanical data

Dim.	mm		
	Min.	Typ.	Max.
A	4.40		4.60
b	0.61		0.88
b1	1.14		1.55
c	0.48		0.70
D	15.25		15.75
D1		1.27	
E	10.00		10.40
e	2.40		2.70
e1	4.95		5.15
F	1.23		1.32
H1	6.20		6.60
J1	2.40		2.72
L	13.00		14.00
L1	3.50		3.93
L20		16.40	
L30		28.90	
øP	3.75		3.85
Q	2.65		2.95

Revision history

Table 12. Document revision history

Date	Version	Changes
07-Jul-2008	1	First release.
10-Sep-2009	2	Document status promoted from preliminary data to datasheet.
27-Jun-2011	3	<i>Section 2.1: Electrical characteristics (curves)</i> has been updated.
07-Mar-2012	4	Updated <i>Section 4: Package mechanical data</i> . Minor text changes.
11-Jul-2018	5	Part numbers STB7N52K3 and STF7N52K3 have been moved to a different datasheet, and the document has been updated accordingly. Updated features and description on cover page. Updated <i>Table 1. Absolute maximum ratings</i> . Updated <i>Section 4.1 DPAK (TO-252) type A2 package information</i> . Minor text changes.
01-Aug-2018	6	Updated Table 1. Absolute maximum ratings .

Contents

1	Electrical ratings	2
2	Electrical characteristics	3
2.1	Electrical characteristics (curves)	5
3	Test circuits	8
4	Package information	9
4.1	DPAK (TO-252) type A2 package information	9
4.2	DPAK (TO-252) type C2 package information	11
4.3	DPAK (TO-252) packing information	14
4.4	TO-220 type A package information	16
	Revision history	19

IMPORTANT NOTICE – PLEASE READ CAREFULLY

STMicroelectronics NV and its subsidiaries (“ST”) reserve the right to make changes, corrections, enhancements, modifications, and improvements to ST products and/or to this document at any time without notice. Purchasers should obtain the latest relevant information on ST products before placing orders. ST products are sold pursuant to ST’s terms and conditions of sale in place at the time of order acknowledgement.

Purchasers are solely responsible for the choice, selection, and use of ST products and ST assumes no liability for application assistance or the design of Purchasers’ products.

No license, express or implied, to any intellectual property right is granted by ST herein.

Resale of ST products with provisions different from the information set forth herein shall void any warranty granted by ST for such product.

ST and the ST logo are trademarks of ST. All other product or service names are the property of their respective owners.

Information in this document supersedes and replaces information previously supplied in any prior versions of this document.

© 2018 STMicroelectronics – All rights reserved

Компания «Life Electronics» занимается поставками электронных компонентов импортного и отечественного производства от производителей и со складов крупных дистрибьюторов Европы, Америки и Азии.

С конца 2013 года компания активно расширяет линейку поставок компонентов по направлению коаксиальный кабель, кварцевые генераторы и конденсаторы (керамические, пленочные, электролитические), за счёт заключения дистрибьюторских договоров

Мы предлагаем:

- Конкурентоспособные цены и скидки постоянным клиентам.
- Специальные условия для постоянных клиентов.
- Подбор аналогов.
- Поставку компонентов в любых объемах, удовлетворяющих вашим потребностям.
- Приемлемые сроки поставки, возможна ускоренная поставка.
- Доставку товара в любую точку России и стран СНГ.
- Комплексную поставку.
- Работу по проектам и поставку образцов.
- Формирование склада под заказчика.
- Сертификаты соответствия на поставляемую продукцию (по желанию клиента).
- Тестирование поставляемой продукции.
- Поставку компонентов, требующих военную и космическую приемку.
- Входной контроль качества.
- Наличие сертификата ISO.

В составе нашей компании организован Конструкторский отдел, призванный помогать разработчикам, и инженерам.

Конструкторский отдел помогает осуществить:

- Регистрацию проекта у производителя компонентов.
- Техническую поддержку проекта.
- Защиту от снятия компонента с производства.
- Оценку стоимости проекта по компонентам.
- Изготовление тестовой платы монтаж и пусконаладочные работы.



Тел: +7 (812) 336 43 04 (многоканальный)

Email: org@lifeelectronics.ru