

HFBR-1312TZ Transmitter

HFBR-2316TZ Receiver

1300 nm Fiber Optic Transmitter and Receiver



Data Sheet

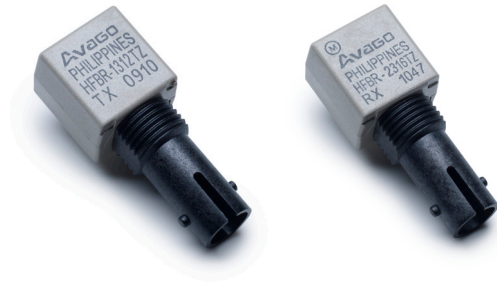

Description

The HFBR-1312TZ Transmitter and HFBR-2316TZ Receiver are designed to provide the most cost-effective 1300 nm fiber optic links for a wide variety of data communication applications from low-speed distance extenders up to SONET OC-3 signal rates. Pinouts identical to Avago HFBR-0400Z Series allow designers to easily upgrade their 820 nm links for farther distance. The transmitter and receiver are compatible with two popular optical fiber sizes: 50/125 μm and 62.5/125 μm diameter. This allows flexibility in choosing a fiber size. The 1300 nm wavelength is in the lower dispersion and attenuation region of fiber, and provides longer distance capabilities than 820 nm LED technology. Typical distance capabilities are 2 km at 125 MBd and 5 km at 32 MBd.

Transmitter

The HFBR-1312TZ fiber optic transmitter contains a 1300 nm InGaAsP light emitting diode capable of efficiently launching optical power into 50/125 μm and 62.5/125 μm diameter fiber. Converting the interface circuit from a HFBR-14XXZ 820 nm transmitter to the HFBR-1312TZ requires only the removal of a few passive components.

Features

- RoHS-compliant
- Low cost fiber optic link
- Signal rates over 155 megabaud
- 1300 nm wavelength
- Link distances over 5 km
- Dual-in-line package panel-mountable ST* and SC connector receptacles
- Auto-insertable and wave-solderable
- Specified with 62.5/125 μm and 50/125 μm fiber
- Compatible with HFBR-0400Z Series
- Receiver also specified for SM cable spec (9/125 μm)

Applications

- Desktop links for high speed LANs
- Distance extension links
- Telecom switch systems
- TAXIchip® compatible

*ST is a registered trademark of AT&T Lightguide Cable Connectors

HFBR-1312TZ Transmitter

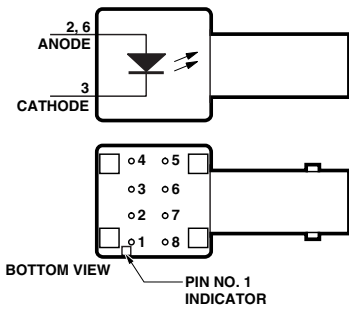

PIN	FUNCTION
1	N.C.
2	ANODE
3	CATHODE
4	N.C.
5	N.C.
6	ANODE
7*	N.C.
8	N.C.

* PIN 7 IS ELECTRICALLY ISOLATED FROM PINS 1, 4, 5, AND 8, BUT IS CONNECTED TO THE HEADER.

PINS 1, 4, 5, AND 8 ARE ISOLATED FROM THE INTERNAL CIRCUITRY, BUT ARE ELECTRICALLY CONNECTED TO EACH OTHER.

HFBR-2316TZ Receiver

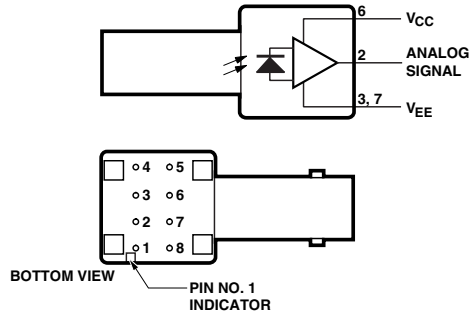

PIN	FUNCTION
1	N.C.
2	SIGNAL
3*	VEE
4	N.C.
5	N.C.
6	VCC
7*	VEE
8	N.C.

* PINS 3 AND 7 ARE ELECTRICALLY CONNECTED TO THE HEADER.

PINS 1, 4, 5, AND 8 ARE ISOLATED FROM THE INTERNAL CIRCUITRY, BUT ARE ELECTRICALLY CONNECTED TO EACH OTHER.

Mechanical Dimensions

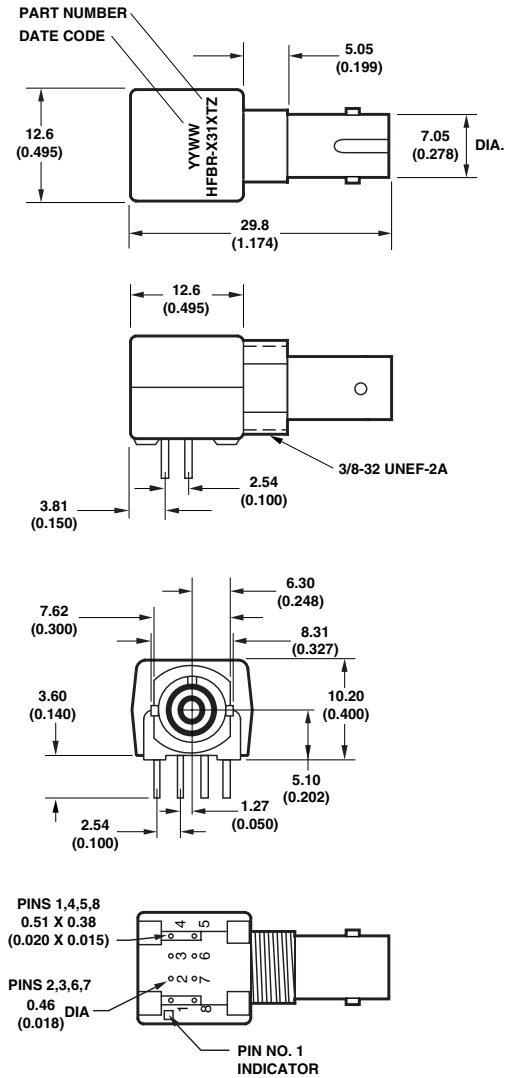

Receiver

The HFBR-2316TZ receiver contains an InGaAs PIN photodiode and a low-noise transimpedance preamplifier that operate in the 1300 nm wavelength region. The HFBR-2316TZ receives an optical signal and converts it to an analog voltage. The buffered output is an emitter-follower, with frequency response from DC to typically 125 MHz. Low-cost external components can be used to convert the analog output to logic compatible signal levels for a variety of data formats and data rates. The HFBR-2316TZ is pin compatible with HFBR-24X6Z receivers and can be used to extend the distance of an existing application by substituting the HFBR-2316TZ for the HFBR-2416Z.

Package Information

The transmitter and receiver are housed in a dual-in-line package made of high strength, heat resistant, chemically resistant, and UL V-0 flame retardant plastic. The package is auto-insertable and wave solderable for high volume production applications.

Note: The "T" in the product numbers indicates a Threaded ST connector (panel mountable), for both transmitter and receiver.

Handling and Design Information

When soldering, it is advisable to leave the protective cap on the unit to keep the optics clean. Good system performance requires clean port optics and cable ferrules to avoid obstructing the optical path. Clean compressed air is often sufficient to remove particles of dirt; methanol on a cotton swab also works well.

Panel Mounting Hardware

The HFBR-4411Z kit consists of 100 nuts and 100 washers with dimensions as shown in Figure 1. These kits are available from Avago or any authorized distributor. Any standard size nut and washer will work, provided the total thickness of the wall, nut, and washer does not exceed 0.2 inch (5.1 mm).

When preparing the chassis wall for panel mounting, use the mounting template in Figure 2. When tightening the nut, torque should not exceed 0.8 N-m (8.0 in-lb).

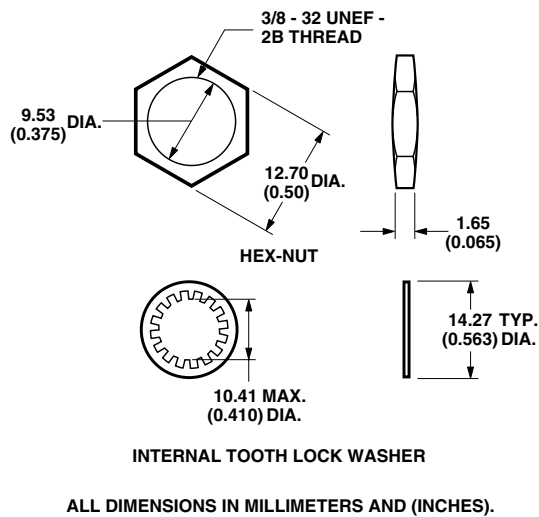

Figure 1. HFBR-4411Z mechanical dimensions

Recommended Chemicals for Cleaning/Degreasing

Alcohols (methyl, isopropyl, isobutyl)
 Aliphatics (hexane, heptane)
 Other (soap solution, naphtha)

Do not use partially halogenated hydrocarbons (such as 1,1,1 trichloroethane), ketones (such as MEK), acetone, chloroform, ethyl acetate, methylene dichloride, phenol, methylene chloride, or N-methylpyrrolidone. Also, Avago does not recommend the use of cleaners that use halogenated hydrocarbons because of their potential environmental harm.

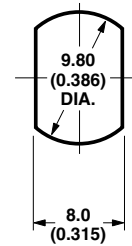

Figure 2. Recommended cut-out for panel mounting

HFBR-1312TZ Transmitter Absolute Maximum Ratings

Parameter	Symbol	Min.	Max.	Unit	Reference
Storage Temperature	T_S	-55	85	°C	
Operating Temperature	T_A	-40	85	°C	
Lead Soldering Cycle Temperature			260	°C	Note 8
Lead Soldering Cycle Time			10	sec	
Forward Input Current DC	I_{FDC}		100	mA	
Reverse Input Voltage	V_R		1	V	

CAUTION: The small junction sizes inherent to the design of this bipolar component increase the component's susceptibility to damage from electrostatic discharge (ESD). It is advised that normal static precautions be taken in handling and assembly of this component to prevent damage and/or degradation which may be induced by ESD.

HFBR-1312TZ Transmitter Electrical/Optical Characteristics

0 to 70°C unless otherwise specified

Parameter	Symbol	Min.	Typ. ^[1]	Max.	Unit	Condition	Ref.
Forward Voltage	V_F	1.1	1.4	1.7	V	$I_F = 75$ mA	Fig. 3
			1.5			$I_F = 100$ mA	
Forward Voltage Temperature Coefficient	$\Delta V_F/\Delta T$		-1.5		mV/°C	$I_F = 75 - 100$ mA	
Reverse Input Voltage	V_R	1	4		V	$I_R = 100$ μ A	
Center Emission Wavelength	λ_C	1270	1300	1370	nm		
Full Width Half Maximum	FWHM		130	185	nm		
Diode Capacitance	C_T		16		pF	$V_F = 0$ V, $f = 1$ MHz	
Optical Power Temperature Coefficient	$\Delta P_T/\Delta T$		-0.03		dB/°C	$I_F = 75 - 100$ mA DC	
Thermal Resistance	Θ_{JA}		260		°C/W		Note 2

HFBR-1312TZ Transmitter Output Optical Power and Dynamic Characteristics

Parameter	Symbol	Min.	Typ. ^[1]	Max.	Unit	Condition		Ref.
						T_A	$I_{F,peak}$	
Peak Power 62.5/125 μ m NA = 0.275	P_{T62}	-16.0	-14.0	-12.5	dBm	25°C	75 mA	Notes 3, 4, 5
		-17.5		-11.5		0-70°C	75 mA	
		-15.5	-13.5	-12.0		25°C	100 mA	Fig. 4
		-17.0		-11.0		0-70°C	100 mA	
Peak Power 50/125 μ m NA = 0.20	P_{T50}	-19.5	-17.0	-14.5	dBm	25°C	75 mA	Notes 3, 4, 5
		-21.0		-13.5		0-70°C	75 mA	
		-19.0	-16.5	-14.0		25°C	100 mA	Fig. 4
		-20.5		-13.0		0-70°C	100 mA	
Optical Overshoot	OS		5	10	%	0-70°C	75 mA	Note 6 Fig. 5
Rise Time	t_r		1.8	4.0	ns	0-70°C	75 mA	Note 7 Fig. 5
Fall Time	t_f		2.2	4.0	ns	0-70°C	75 mA	Note 7 Fig. 5

Notes:

1. Typical data are at $T_A = 25^\circ\text{C}$.
2. Thermal resistance is measured with the transmitter coupled to a connector assembly and mounted on a printed circuit board;
 $\Theta_{JC} < \Theta_{JA}$.
3. Optical power is measured with a large area detector at the end of 1 meter of mode stripped cable, with an ST* precision ceramic ferrule (MIL-STD-83522/13), which approximates a standard test connector. Average power measurements are made at 12.5 MHz with a 50% duty cycle drive current of 0 to $I_{F,peak}$; $I_{F,average} = I_{F,peak}/2$. Peak optical power is 3 dB higher than average optical power.
4. When changing from μW to dBm, the optical power is referenced to 1 mW (1000 μW).
 Optical power P(dBm) = $10 \cdot \log[P(\mu\text{W})/1000\mu\text{W}]$.
5. Fiber NA is measured at the end of 2 meters of mode stripped fiber using the far-field pattern. NA is defined as the sine of the half angle, determined at 5% of the peak intensity point. When using other manufacturer's fiber cable, results will vary due to differing NA values and test methods.
6. Overshoot is measured as a percentage of the peak amplitude of the optical waveform to the 100% amplitude level. The 100% amplitude level is determined at the end of a 40 ns pulse, 50% duty cycle. This will ensure that ringing and other noise sources have been eliminated.
7. Optical rise and fall times are measured from 10% to 90% with 62.5/125 μm fiber. LED response time with recommended test circuit (Figure 3) at 25 MHz, 50% duty cycle.
8. 2.0 mm from where leads enter case.

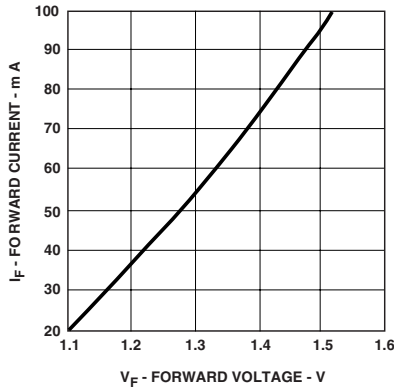

Figure 3. Typical forward voltage and current characteristics

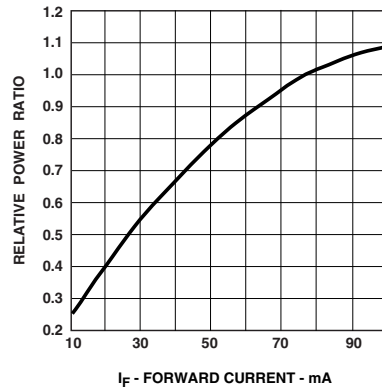

Figure 4. Normalized transmitter output power vs. forward current

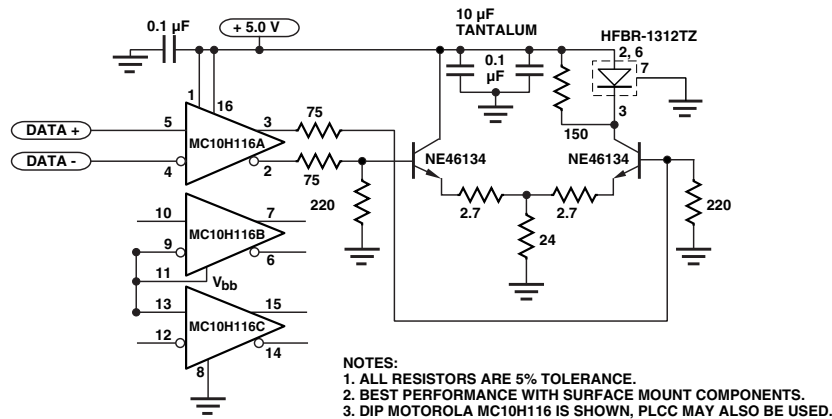

Figure 5. Recommended transmitter drive and test circuit

HFBR-2316TZ Receiver Absolute Maximum Ratings

Parameter	Symbol	Min.	Max.	Unit	Reference
Storage Temperature	T_S	-55	85	°C	
Operating Temperature	T_A	-40	+85	°C	
Lead Soldering Temperature			260	°C	Note 1
Cycle Time			10	s	
Signal Pin Voltage	V_O	-0.5	V_{CC}	V	
Supply Voltage	$V_{CC} - V_{EE}$	-0.5	6.0	V	Note 2
Output Current	I_O		25	mA	

CAUTION: The small junction sizes inherent to the design of this bipolar component increase the component's susceptibility to damage from electrostatic discharge (ESD). It is advised that normal static precautions be taken in handling and assembly of this component to prevent damage and/or degradation which may be induced by ESD.

HFBR-2316TZ Receiver Electrical/Optical and Dynamic Characteristics

0 to 70°C; $4.75\text{ V} < V_{CC} - V_{EE} < 5.25\text{ V}$; power supply must be filtered (see note 2).

Parameter	Symbol	Min.	Typ. ^[3]	Max.	Unit	Condition	Ref.
Responsivity	R_p 62.5 μm	6.5	13	19	mV/ μW	$\lambda_p = 1300\text{ nm}$, 50 MHz Multimode Fiber 62.5/125 μm	Note 4 Fig. 6, 10
	R_p 9 μm	8.5	17			Singlemode Fiber 9/125 μm	
RMS Output Noise Voltage	V_{NO}		0.4	0.59	mV _{RMS}	100 MHz Bandwidth, $P_R = 0\ \mu\text{W}$	Note 5 Fig. 7
				1.0	mV _{RMS}	Unfiltered Bandwidth $P_R = 0\ \mu\text{W}$	
Equivalent Optical Noise Input Power (RMS)	$P_{N,RMS}$		-45	-41.5	dBm	@ 100 MHz, $P_R = 0\ \mu\text{W}$	Note 5
			0.032	0.071	μW		
Peak Input Optical Power	P_R			-11.0	dBm	50 MHz, 1 ns PWD	Note 6
				80	μW		Fig. 8
Output Resistance	R_O		30		Ohm	$f = 50\text{ MHz}$	
DC Output Voltage	$V_{O,DC}$	0.8	1.8	2.6	V	$V_{CC} = 5\text{ V}$, $V_{EE} = 0\text{ V}$ $P_R = 0\ \mu\text{W}$	
Supply Current	I_{CC}		9	15	mA	$R_{LOAD} = \infty$	
Electrical Bandwidth	BW_E	75	125		MHz	-3 dB electrical	Note 7
Bandwidth * Rise Time Product			0.41		Hz * s		Note 11
Electrical Rise, Fall Times, 10-90%	t_r, t_f		3.3	5.3	ns	$P_R = -15\text{ dBm peak}$, @ 50 MHz	Note 8 Fig. 9
Pulse-Width Distortion	PWD		0.4	1.0	ns	$P_R = -11\text{ dBm, peak}$	Note 6,9 Fig. 8
Overshoot			2		%	$P_R = -15\text{ dBm, peak}$	Note 10

Notes:

- 2.0 mm from where leads enter case.
- The signal output is referred to V_{cc} and does not reject noise from the V_{cc} power supply. Consequently, the V_{cc} power supply must be filtered. The recommended power supply is +5 V on V_{cc} for typical usage with +5 V ECL logic. A -5 V power supply on V_{ee} is used for test purposes to minimize power supply noise.
- Typical specifications are for operation at $T_A = 25^\circ\text{C}$ and $V_{cc} = +5 V_{DC}$.
- The test circuit layout should be in accordance with good high frequency circuit design techniques.
- Measured with a 9-pole "brick wall" low-pass filter [Mini-Circuits™, BLP-100*] with -3 dB bandwidth of 100 MHz.
- 11.0 dBm is the maximum peak input optical power for which pulse-width distortion is less than 1 ns.
- Electrical bandwidth is the frequency where the responsivity is -3 dB (electrical) below the responsivity measured at 50 MHz.
- The specified rise and fall times are referenced to a fast square wave optical source. Rise and fall times measured using an LED optical source with a 2.0 ns rise and fall time (such as the HFBR-1312TZ) will be approximately 0.6 ns longer than the specified rise and fall times.
E.g.: measured $t_{r,f} \approx [(\text{specified } t_{r,f})^2 + (\text{test source optical } t_{r,f})^2]^{1/2}$.
- 10 ns pulse width, 50% duty cycle, at the 50% amplitude point of the waveform.
- Percent overshoot is defined as: $((V_{PK} - V_{100\%})/V_{100\%}) \times 100\%$. The overshoot is typically 2% with an input optical rise time ≤ 1.5 ns.
- The bandwidth*risetime product is typically 0.41 because the HFBR-2316TZ has a second-order bandwidth limiting characteristic.

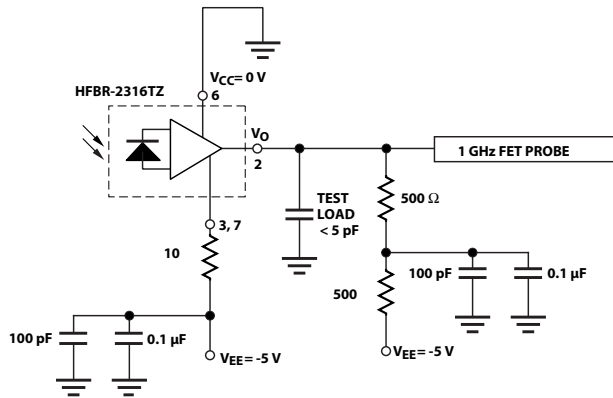

Figure 6. HFBR-2316TZ receiver test circuit

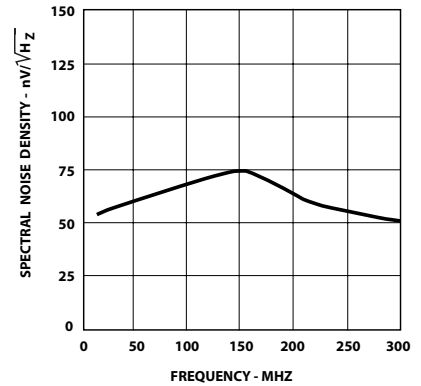

Figure 7. Typical output spectral noise density vs. frequency

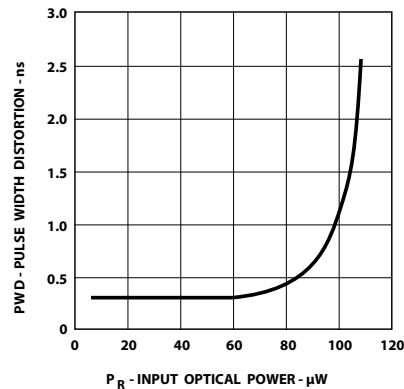

Figure 8. Typical pulse width distortion vs. peak input power.

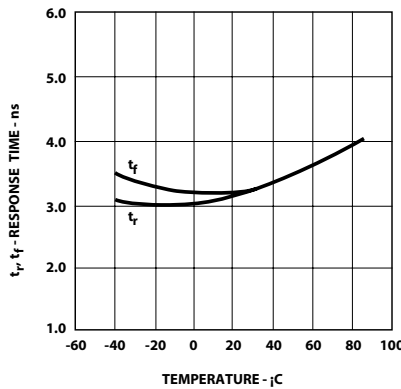

Figure 9. Typical rise and fall times vs. temperature

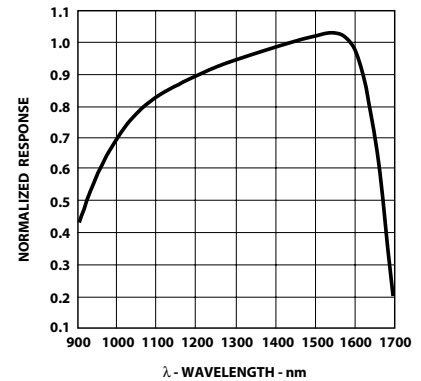

Figure 10. Normalized receiver spectral response

*Mini-Circuits Division of Components Corporation.

For product information and a complete list of distributors, please go to our web site: www.avagotech.com

Avago, Avago Technologies, and the A logo are trademarks of Avago Technologies in the United States and other countries. Data subject to change. Copyright © 2005-2012 Avago Technologies. All rights reserved. AV02-1500EN - January 12, 2012



Компания «Life Electronics» занимается поставками электронных компонентов импортного и отечественного производства от производителей и со складов крупных дистрибьюторов Европы, Америки и Азии.

С конца 2013 года компания активно расширяет линейку поставок компонентов по направлению коаксиальный кабель, кварцевые генераторы и конденсаторы (керамические, пленочные, электролитические), за счёт заключения дистрибьюторских договоров

Мы предлагаем:

- Конкурентоспособные цены и скидки постоянным клиентам.
- Специальные условия для постоянных клиентов.
- Подбор аналогов.
- Поставку компонентов в любых объемах, удовлетворяющих вашим потребностям.
- Приемлемые сроки поставки, возможна ускоренная поставка.
- Доставку товара в любую точку России и стран СНГ.
- Комплексную поставку.
- Работу по проектам и поставку образцов.
- Формирование склада под заказчика.
- Сертификаты соответствия на поставляемую продукцию (по желанию клиента).
- Тестирование поставляемой продукции.
- Поставку компонентов, требующих военную и космическую приемку.
- Входной контроль качества.
- Наличие сертификата ISO.

В составе нашей компании организован Конструкторский отдел, призванный помогать разработчикам, и инженерам.

Конструкторский отдел помогает осуществить:

- Регистрацию проекта у производителя компонентов.
- Техническую поддержку проекта.
- Защиту от снятия компонента с производства.
- Оценку стоимости проекта по компонентам.
- Изготовление тестовой платы монтаж и пусконаладочные работы.



Тел: +7 (812) 336 43 04 (многоканальный)
Email: org@lifeelectronics.ru