

General Description

The MAX2678 evaluation kit (EV kit) is an easy-to-use platform that enables straightforward evaluation of the MAX2678 two-stage high-performance GPS LNA, which is designed for use in demanding automotive applications and provides 35dB gain. The EV kit includes all functionality that would typically be found in a typical remote antenna module, with the exception of a 12V regulator. Optimal matching and coupling circuits are included on the EV kit, enabling “plug and play” operation. In many applications, an interstage SAW filter is used to maximize immunity to out-of-band interferers. A pair of common SAW filter footprints are available to enable evaluation in this configuration. Resistor options are provided to enable stand-alone testing of either gain stage or cascade testing of the two gain stages and optional SAW filter. Interfacing the MAX2678 EV kit to RF test equipment is streamlined using industry-standard SMA connectors.

Benefits and Features

- Flexible Evaluation of the MAX2678 IC
 - Stand-Alone AMP 1 or AMP 2 Configuration
 - Cascade Configuration with Interstage SAW Filter*
- Optimal Matching and Coupling Eliminates Tuning
- All Ports Matched to 50Ω and Accessible through SMA Connectors for Simple Interfacing
- Proven PCB Layout
- Fully Assembled and Tested

*SAW filter not included.

Ordering Information appears at end of data sheet.

MAX2678 EV Kit Board Photo

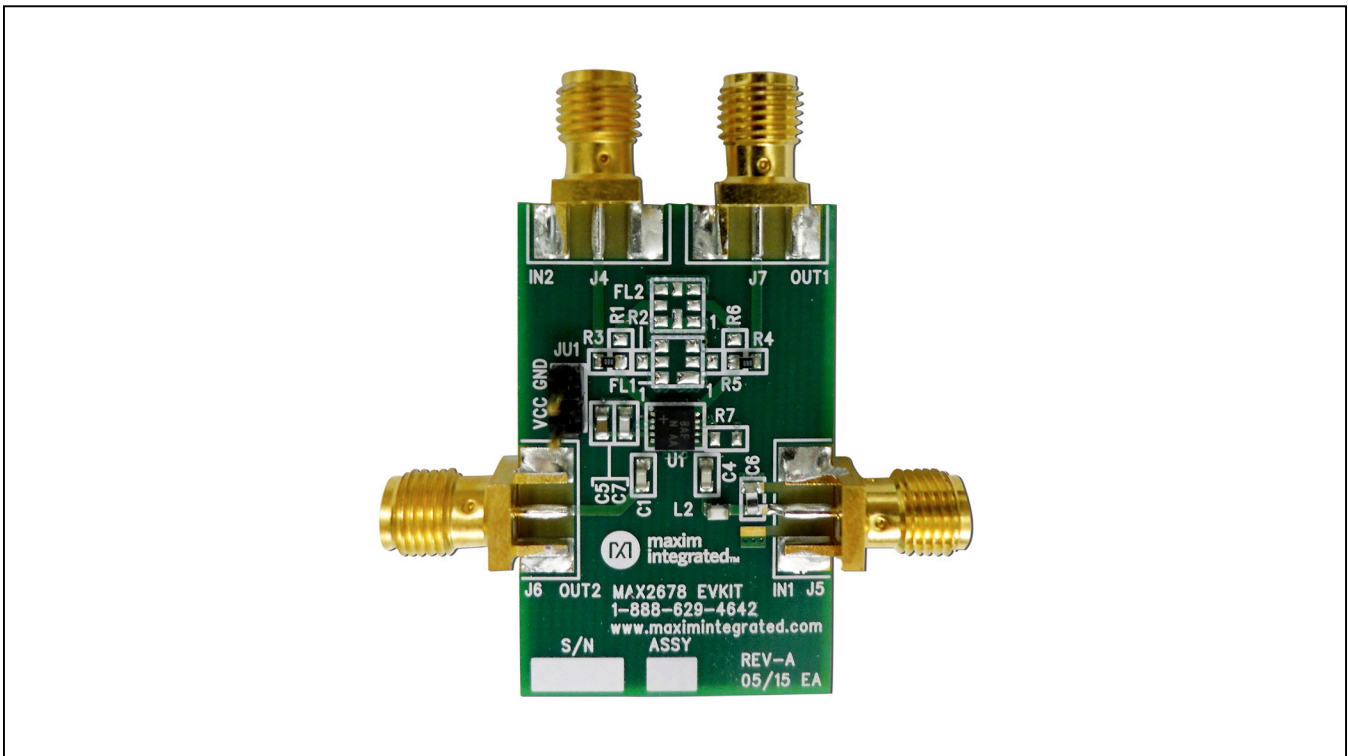

Quick Start

Required Equipment

- MAX2678 EV kit
- Linear DC power supply capable of sourcing at least 100mA between 3V and 5.25V
- Network analyzer
- Noise figure meter
- Two RF signal generators with maximum RF power level of at least 0dBm
- Spectrum analyzer
- Power meter

Procedure

The EV kit is fully assembled and tested and can be tested directly out of the box. The following procedures provide examples of how to measure common specifications of the MAX2678.

Measure the Stand-Alone Gain of Each Gain Stage

Follow the steps below to measure the stand-alone gain of each of the two gain stages. Full 2-port S parameters can be measured using this procedure, but be aware that the observed angle will not be referenced to the device's pins. Detailed discussion of calibrating S parameter measurements is beyond the scope of this document.

- 1) Configure the network analyzer with -35dBm RF power level and 800MHz to 2000MHz frequency span.
- 2) Perform 2-port calibration of the network analyzer.
- 3) Disable power-supply output, adjust output level to 5V, and set current limit to at least 100mA.
- 4) Connect supply leads to connector JU1 on the EV kit.
- 5) Connect network analyzer to AMP 1 (Port 1 = J5, Port 2 = J7).
- 6) Enable power supply.
- 7) Measure $|S_{21}|$ of AMP 1.
- 8) Disable power supply.
- 9) Connect network analyzer to AMP 2 (Port 1 = J4, Port 2 = J6).
- 10) Enable power supply.
- 11) Measure $|S_{21}|$ of AMP 2. By default, AMP 2 is in high-gain mode (component R7 open).

Measure IP3 of AMP 1 (AMP 2 Can be Measured in a Similar Manner)

This procedure details how to conduct a two-tone test for IP3. Note that two signal generators are required. Always be aware of the possibility of interaction between the signal generators, although the power levels used in this case are modest, so this is only a moderate concern. Regardless, it is a good idea to use attenuators or isolators to ensure sufficient isolation and to be prepared for some troubleshooting and a few iterations of testing.

- 1) Disable RF generators and connect them together through a hybrid combiner.
- 2) Set RF frequencies of generators to 1575MHz and 1576MHz, respectively.
- 3) Connect output of combiner to power meter.
Enable generators one at a time and adjust the output level such that each generator is delivering -35dBm to the power meter (depending on the power meter, the level may need to be calibrated at a higher level and then backed off to achieve the desired -35dBm value).
- 4) Disable signal generators, connect combiner output to spectrum analyzer, and then enable generators.
- 5) Adjust spectrum analyzer and confirm that IM3 products cannot be observed at 1574MHz or 1577MHz. If IM tones are observed, adjust spectrum-analyzer attenuation level to confirm whether the IM is generated in the spectrum analyzer or generators. If the IM is created by the signal generators, add additional isolation and recalibrate the level as needed.
- 6) Disable generators and then connect output of combiner to the AMP 1 input (IN1, J5).
- 7) Connect output of AMP 1 (OUT1, J7) to spectrum analyzer and increase spectrum-analyzer attenuation by approximately 15dB (this helps to eliminate uncertainty whether any distortion is generated in the spectrum analyzer).
- 8) Confirm 5V power supply connection to EV kit connector JU1 and then enable the supply output.
- 9) Enable signal-generator outputs.
- 10) Measure IM3 using spectrum analyzer and calculate IP3 assuming input power level of -35dBm/tone.

Measure P_{1dB} of AMP 1 (AMP 2 Can be Measured in a Similar Manner)

This procedure can be used to measure gain compression. Note that this is a single-tone test.

- 1) Disable RF generator output and configure with 1575MHz RF frequency and -30dBm power level.
- 2) Connect generator to AMP 1 input (IN1, J5).
- 3) Connect spectrum analyzer to AMP 1 output (OUT1, J7).
- 4) Confirm 5V power-supply connection to EV kit connector JU1 and then enable the supply output.
- 5) Enable signal generator.
- 6) Observe gain using spectrum analyzer. This is a high-power measurement, so confirm that the front-end attenuator is adjusted appropriately to avoid compression in the spectrum analyzer.
- 7) Increase power in 1dB steps. Observe gain for each step. Note input level at which gain is reduced from initially observed value (step 6) by 1dB.

Measure Noise Figure of AMP 1 (AMP 2 Can be Measured in a Similar Manner)

Measurement of noise figure is especially challenging because of the MAX2678's excellent noise performance. Some experimentation may be required to obtain the best results. As a general rule, try to avoid clutter around the EV kit and ensure that obvious radiators of noise are not in close proximity to the test fixture. It may be helpful to use a shielded enclosure for this measurement.

- 1) Calibrate noise figure meter and test fixture at operating frequency of the IC.
- 2) Connect noise figure meter to input and output ports of AMP 1.
- 3) Confirm 5V power-supply connection to EV kit connector JU1 and then enable supply output.
- 4) Observe noise figure.

Detailed Description of Hardware**SAW Filter**

The MAX2678 should be used in conjunction with an interstage SAW filter for optimal immunity to out-of-band interferers. The EV kit enables evaluation of the device with a pair of optional industry-standard SAW filters. Resistor jumpers are used to realize the required signal routing. Refer to the schematic for details regarding the resistor configuration. Only one SAW filter should be used at a given time. Refer to the BOM information at the end of this document for specific details regarding the SAW filters.

RF Signal-Routing Options

As previously mentioned, resistor jumpers are used to configure the signal path, depending on whether stand-alone or cascade/SAW filter testing is desired. Only one of the three available overlapping resistor locations in each signal-routing junction should be populated at a given time to avoid creating stubs. It is recommended that 0Ω film resistors be used since they offer very low inductance.

Gain Select

AMP 2 includes a 3.4dB gain step. This enables the gain to be tailored to specific applications and adjusted based on loss in the SAW filter. The gain mode is controlled by resistor R7, which configures AMP 2 for high gain. By default, R7 is not installed. To enable low-gain mode, install a 0Ω resistor in location R7.

Layout Considerations

Taking full advantage of the IC's excellent noise performance requires careful PCB layout. The input to AMP 1 is the most sensitive to noise pickup. Everything downstream of AMP 1's output is much less sensitive due to the high gain of AMP 1. Therefore, the IC should be oriented to optimize the interconnect between AMP 1's input and the antenna. In general, this interconnect should be kept as short as possible to achieve the best possible performance, and should be isolated from suspected noise sources by a combination of shielding and proper floor planning. Controlled impedance should be used on all RF interconnects to avoid any unpredictable behavior, and all matching components and decoupling capacitors should be placed in close proximity to the IC package.

Ordering Information

PART	TYPE
MAX2678EVKIT#	EV Kit

#Denotes RoHS compliant.

MAX2678 EV Bill of Materials

REFERENCE DESIGNATOR	QTY	VALUE	DESCRIPTION	MANUFACTURER	MFG. PART NUMBER
C1, C4	2	33pF	0603 Capacitor	Murata	C0603C330K1GAC
C5	2	0.1uF	0603 Capacitor	Murata	GRM188R72A104KA35
C6	1	1.2pF	0603 Capacitor	Kemet	C0603C129C1G
C7	2	100pF	0603 Capacitor	Murata	GRM1885C1H101JA01
FL1	0	1575.42 MHz DNI	Low Loss SAW Filter	RF Monolithics Inc	SF1186B-2
FL2	0	1575.42 MHz DNI	Low Loss SAW Filter	Epcos	B39162-B4059-U810
J4, J5, J6, J7	4	Connector	SMA End Launch Jack Receptacle 0.062"	Johnson	142-0711-821
JU1	1	1X2 Header	Two Pin Header; 100 Mil Centers	Sullins	PEC36SAAN
L2	1	3.9nH	0603 Inductor	Murata	LQW18AN3N9C00
R1, R2, R5, R6, R7	0	DNI	0603 Resistor		
R3, R4	2	0Ω	Resistors		CR0603-16W-000RJT
U1	1	MAX2678	GPS LNA	Maxim Integrated Products	MAX2678GTB/V+
—	1	—	PCB: MAX2678 EVKIT	—	—

MAX2678 EV Kit Schematics

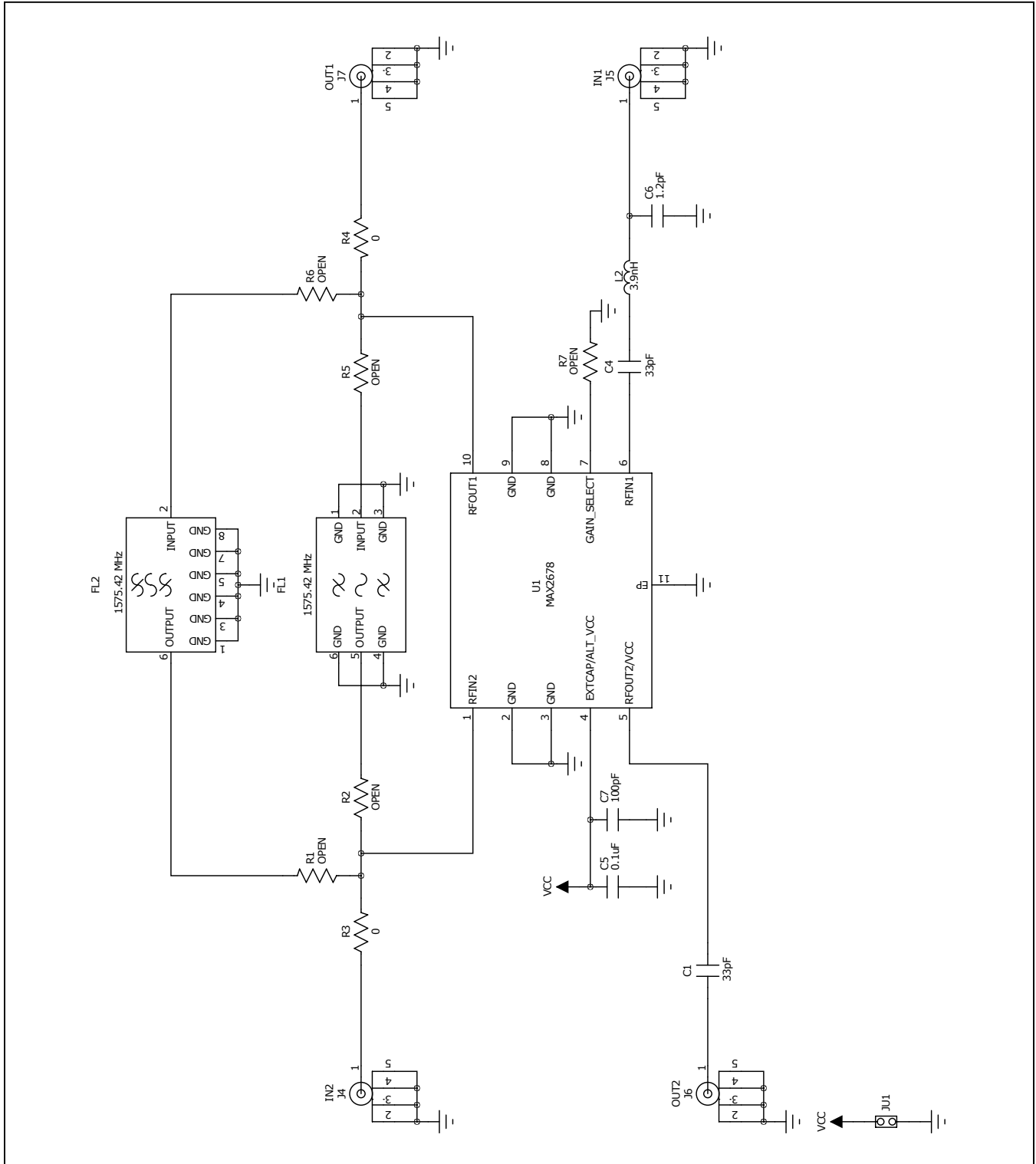

MAX2678 EV Kit Layout Diagrams

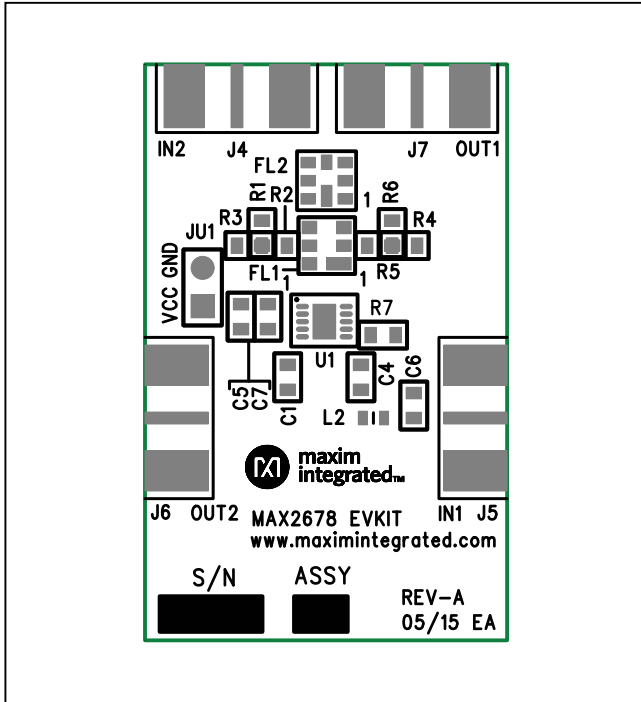

MAX2678 EV Kit Component Side—Top Silkscreen

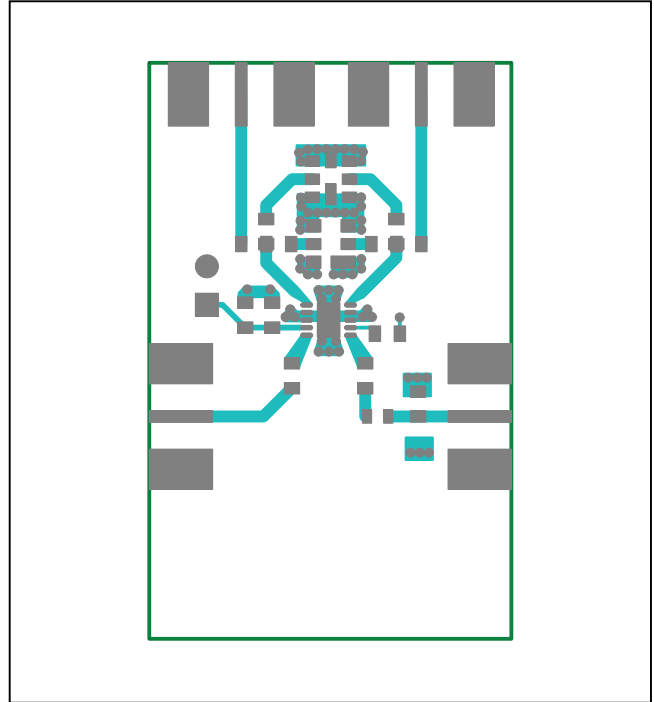

MAX2678 EV Kit Component Side—Component Side

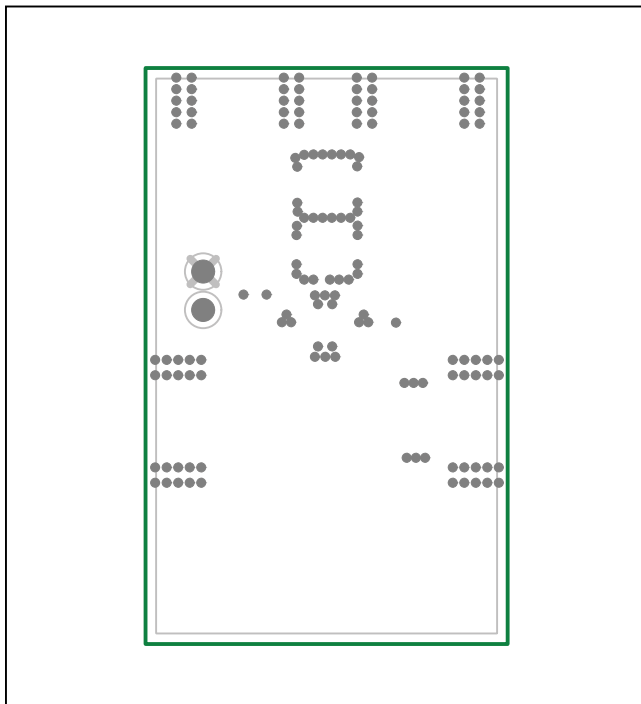

MAX2678 EV Kit PCB Layout—Layer 2 (GND)

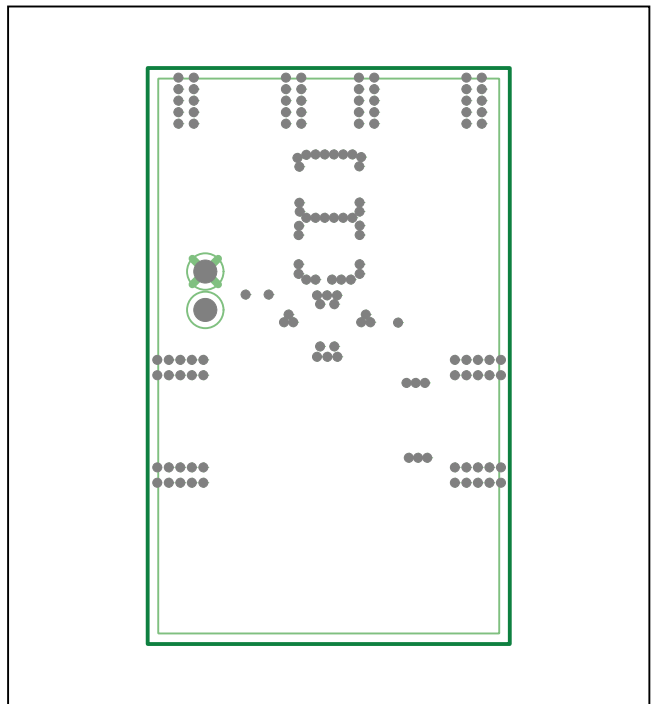

MAX2678 EV Kit PCB Layout—Layer 3 (GND)

MAX2678 EV Kit Layout Diagrams (continued)

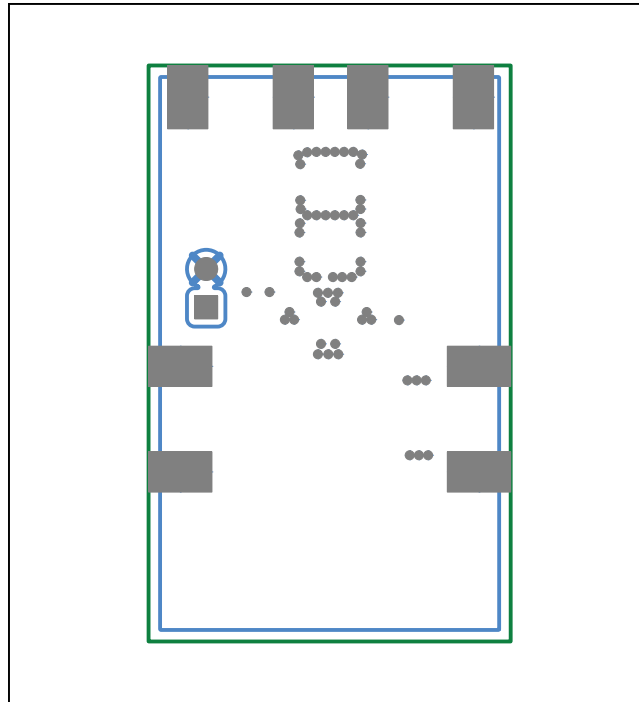

MAX2678 EV Kit PCB Layout—Solder Side

Revision History

REVISION NUMBER	REVISION DATE	DESCRIPTION	PAGES CHANGED
0	11/16	Initial release	—

For pricing, delivery, and ordering information, please contact Maxim Direct at 1-888-629-4642, or visit Maxim Integrated's website at www.maximintegrated.com.

Maxim Integrated cannot assume responsibility for use of any circuitry other than circuitry entirely embodied in a Maxim Integrated product. No circuit patent licenses are implied. Maxim Integrated reserves the right to change the circuitry and specifications without notice at any time.

Компания «Life Electronics» занимается поставками электронных компонентов импортного и отечественного производства от производителей и со складов крупных дистрибьюторов Европы, Америки и Азии.

С конца 2013 года компания активно расширяет линейку поставок компонентов по направлению коаксиальный кабель, кварцевые генераторы и конденсаторы (керамические, пленочные, электролитические), за счёт заключения дистрибьюторских договоров

Мы предлагаем:

- Конкурентоспособные цены и скидки постоянным клиентам.
- Специальные условия для постоянных клиентов.
- Подбор аналогов.
- Поставку компонентов в любых объемах, удовлетворяющих вашим потребностям.
- Приемлемые сроки поставки, возможна ускоренная поставка.
- Доставку товара в любую точку России и стран СНГ.
- Комплексную поставку.
- Работу по проектам и поставку образцов.
- Формирование склада под заказчика.
- Сертификаты соответствия на поставляемую продукцию (по желанию клиента).
- Тестирование поставляемой продукции.
- Поставку компонентов, требующих военную и космическую приемку.
- Входной контроль качества.
- Наличие сертификата ISO.

В составе нашей компании организован Конструкторский отдел, призванный помогать разработчикам, и инженерам.

Конструкторский отдел помогает осуществить:

- Регистрацию проекта у производителя компонентов.
- Техническую поддержку проекта.
- Защиту от снятия компонента с производства.
- Оценку стоимости проекта по компонентам.
- Изготовление тестовой платы монтаж и пусконаладочные работы.



Тел: +7 (812) 336 43 04 (многоканальный)

Email: org@lifeelectronics.ru