

GPIO ICs Series

GPIO Expander IC

BU1850MUV

No.09098EAT02

●Description

GPIO expander is useful especially for the application that is in short of IO ports.

It can

1. Control GPIO output states by I²C write protocol.
2. Know GPIO input states by I²C read protocol.

Furthermore, it has the interrupt function that can release CPU from polling the registers in the GPIO expander. GPIO expander are also equipped with Built-in power on reset, 3V tolerant input, and NMOS open-drain output.

●Features

- 1) An 8-Port General purpose input/output interface 150kΩ Pull-down resistance.
- 2) NMOS Open-drain output interrupt controller with up to 1us pulse noise filter and bit mask function for individual GPIO port.
- 3) 3volt tolerant Input
- 4) Built-in Power On Reset
- 5) 3mmx3mm small package

●Absolute maximum ratings

(Ta=25 °C)

Parameter	Symbol	Rating	Unit	comment
Supply Voltage ^{*1}	VDD	-0.3 ~ +4.5	V	VDD ≤ VDDIO
	VDDIO	-0.3 ~ +4.5	V	
Input voltage	VI	-0.3 ~ VDD +0.3 ^{*1}	V	XRST, ADR
	VIT	-0.3 ~ 4.5	V	XINT, SCL, SDA, GPIO[7:0]
Storage temperature range	Tstg	-55 ~ +125	°C	
Package power	PD	272 ^{*2}	mW	

This IC is not designed to be X-ray proof.

*1 It is prohibited to exceed the absolute maximum ratings even including +0.3 V.

*2 Package dissipation will be reduced each 2.72mW/°C when the ambient temperature increases beyond 25 °C.

●Operating conditions

Parameter	Symbol	Min	Typ	Max	Unit	Conditions
Supply voltage range (VDD)	V _{VDD}	1.65	1.80	3.6	V	Core, XINT, XRST, SCL, SDA, ADR, Power On Reset
Supply voltage range (VDDIO)	V _{VDDIO}	1.65	1.80	3.6	V	GPIO[7:0]
Input voltage range	V _{IN}	-0.2	-	V _{VDD} +0.2	V	XRST, ADR
	V _{INT}	-0.2	-	3.6	V	XINT, SCL, SDA, GPIO[7:0]
Operating temperature range	Topr	-30	-	+85	°C	
I ² C operating frequency	F _{I2C}	-	-	400	kHz	Slave

● Package Specification

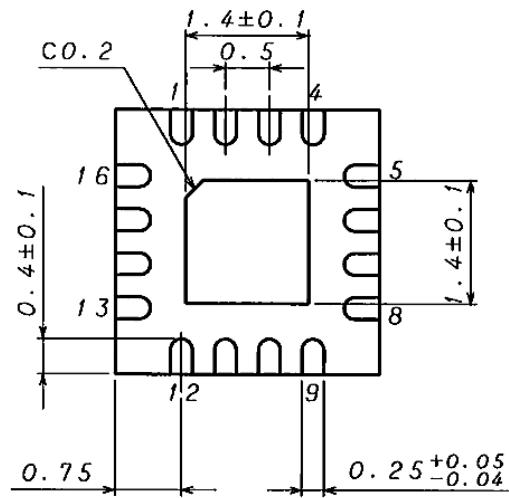
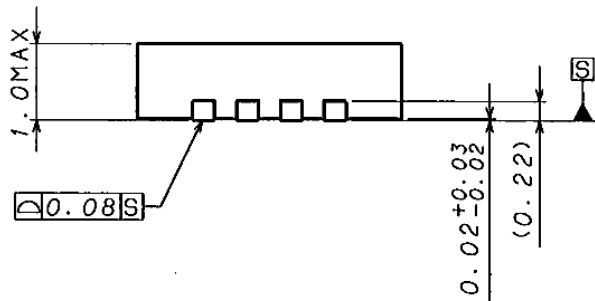
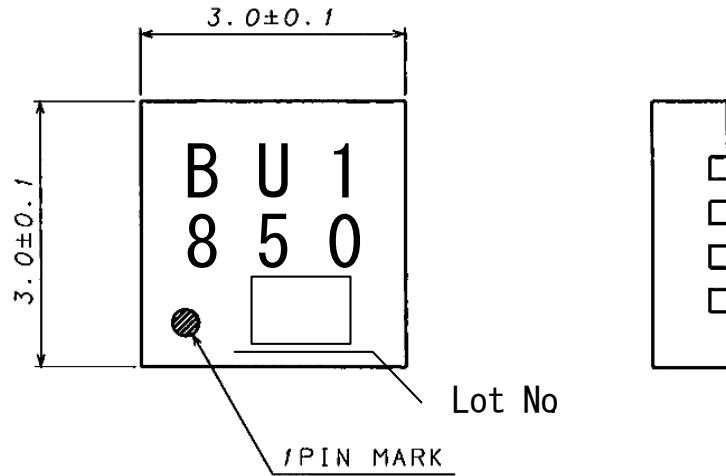

(UNIT: mm)

Fig.1 Package Specification (VQFN016V3030)

● Pin Assignment

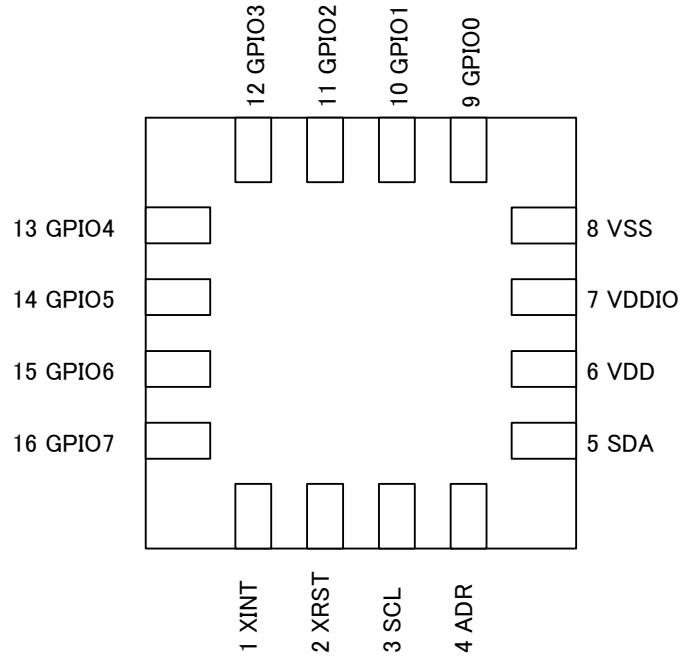

Fig.2 Pin Diagram (Top View)

● Block Diagram

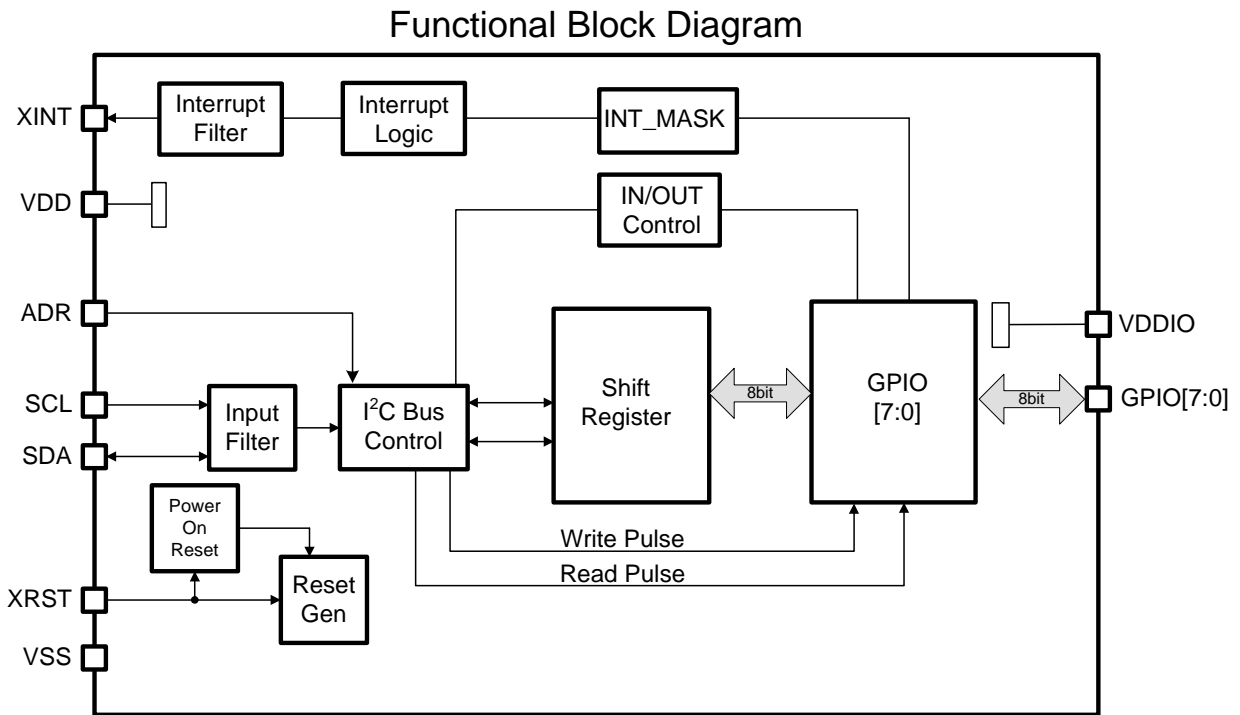

Fig.3 Functional Block Diagram

● Pin-out Functional Descriptions

PIN No.	PIN name	I/O	Power source system	Function	Init	Cell Type
1	XINT	O	VDD	Interrupt signal (1μs pulse cut) ^{*1} (NMOS Open-drain)	Hi-Z	B
2	XRST	I	VDD	Reset (Low Active)	I	E
3	SCL	I	VDD	Clock for I ² C	I	A
4	ADR	I	VDD	Select device address of I ² C	I	E
5	SDA	I/O	VDD	Serial data inout for I ² C (NMOS Open-drain)	Hi-Z	C
6	VDD	-	-	Power supply (Core, I/O, Power On Reset)	-	-
7	VDDIO	-	-	Power supply (I/O)	-	-
8	VSS	-	-	GND	-	-
9	GPIO0	I/O	VDDIO	General purpose input/output. (NMOS Open-drain ^{*2} /CMOS Output, 150kΩ Pull-down ^{*3})	I Pull-down	D
10	GPIO1	I/O	VDDIO			
11	GPIO2	I/O	VDDIO			
12	GPIO3	I/O	VDDIO			
13	GPIO4	I/O	VDDIO			
14	GPIO5	I/O	VDDIO			
15	GPIO6	I/O	VDDIO			
16	GPIO7	I/O	VDDIO			

*1 Specific bit mask control is decided by internal register value.
 *2 Pull-up more than VDDIO voltage.
 *3 It is possible to select Pull-down ON or OFF with register.

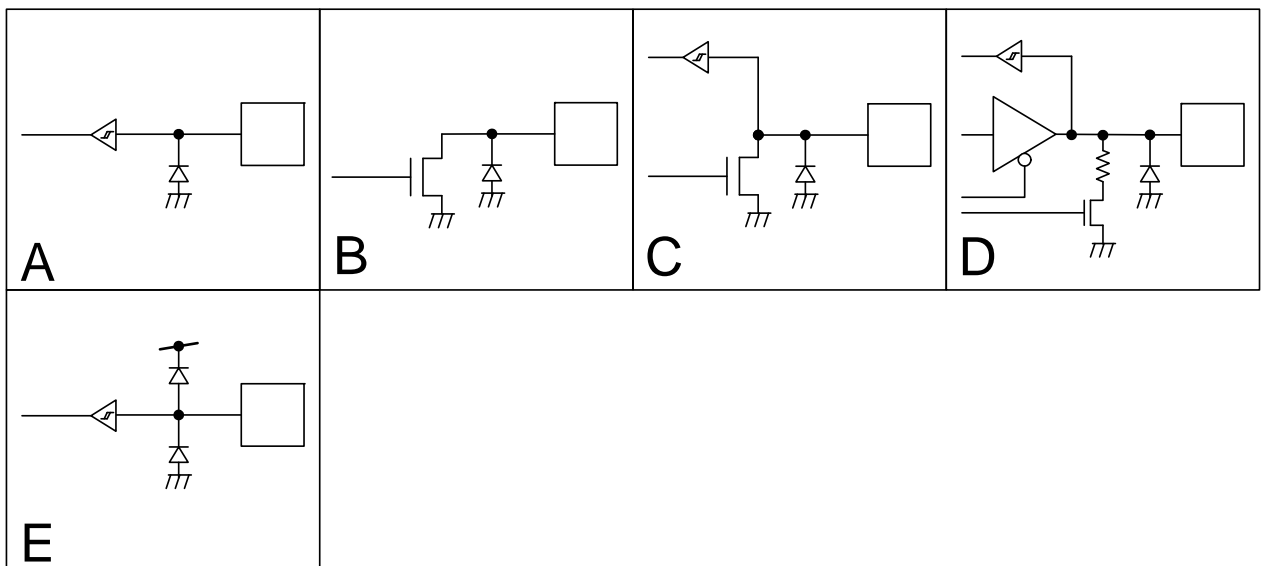

Fig.4 Equivalent IO circuit diagram

●Functional Description

1. Power Modes

The device enters the state of Power Down when XRST="Low" or enters the operation state when XRST=High after powered.

Refer to "Electrical Specification" section 5 for a detailed startup sequence.

1-1 Power supply

A single supply to Core power supply (VDD) and IO power supply (VDDIO) is prohibited.

Supply the power supply to the Core power supply and the IO power supply at the same time.

1-2 Power On Reset

A Power On Reset logic is implemented in this device. Therefore, it will operate correctly even if the XRST port is not used. In this case, the XRST port must be connected to high(VDD).

1-3 State of Power Down

The device enters the state of Power Down by XRST="Low". An internal circuit is initialized and I²C interface is invalid is input. Power On Reset becomes inactive during this state.

1-4 State of operation

The device enters the operation state by setting XRST to "High". The I²C interface starts communication is the START condition. It becomes standby by the STOP condition. Power On Reset is active in this state.

2. I²C Bus Interface

Each function of GPIO is controlled by an internal register. The I²C Slave interface is used to write or read this internal register. The device supports up to 400kHz Fast-mode data transfer rate.

2-1 Slave address

Two device addresses (Slave address) can be selected by ADR port.

	A7	A6	A5	A4	A3	A2	A1	R/W
ADR=0	0	0	0	1	0	0	1	1/0
ADR=1	0	0	0	1	1	1	0	

2-2 Data transfer

One bit of data is transferred during SCL = "1". During the bit transfer SCL = "1" cycle, the signal SDA should keep the value. If SDA changes during SCL = "1", a START condition or STOP condition occur and it is interpreted as a control signal.

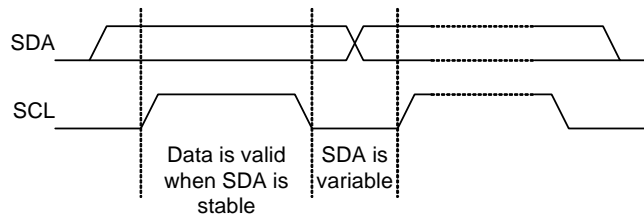

Fig.5 Data transfer

2-3 START-STOP-Repeated START conditions

When SDA and SCL are "1", the data isn't transferred on the 2-wire bus. If SCL remains "1" and SDA transfers from "1" to "0", it means a "Start condition" is occurred and access is started.

If SCL remains "1" and SDA transfers from "0" to "1", it means a "Stop condition" is occurred and access is stopped.

It becomes repeated START condition (Sr) the START condition enters again although the STOP condition is not done.

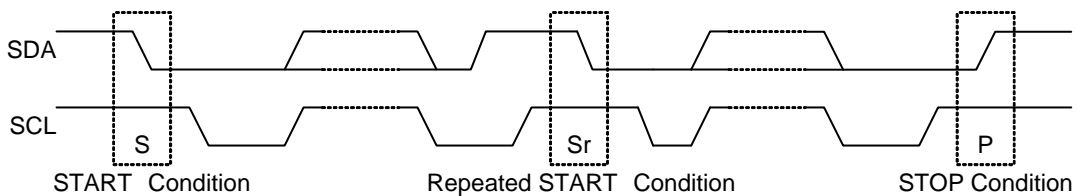

Fig.6 START-STOP-Repeated START conditions

2-4 Acknowledge

After start condition is occurred, 8 bits data will be transferred. SDA is latched by the rising edge of SCL. Then the "Master" opens SDA to "1" and "Slave" de-asserts SDA to "0" as an "Acknowledge" returned.

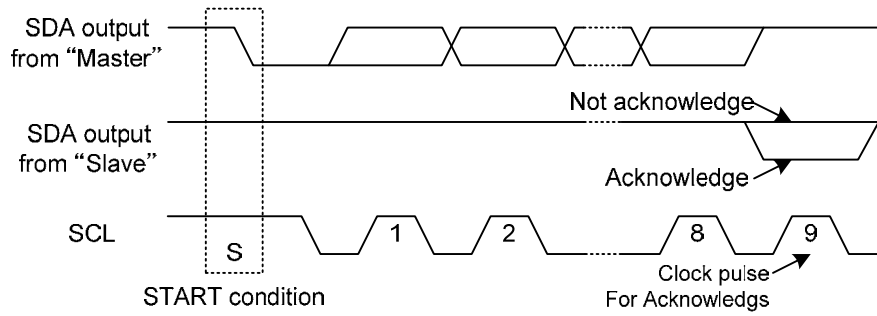

Fig.7 Acknowledge

2-5 Writing protocol

Register address is transferred after one byte of slave address with R/W bit. The 3rd byte data is written to internal register which defined by the 2nd byte. However, when the register address increased to the final address (13h), it will be reset to (00h) after the byte transfer.

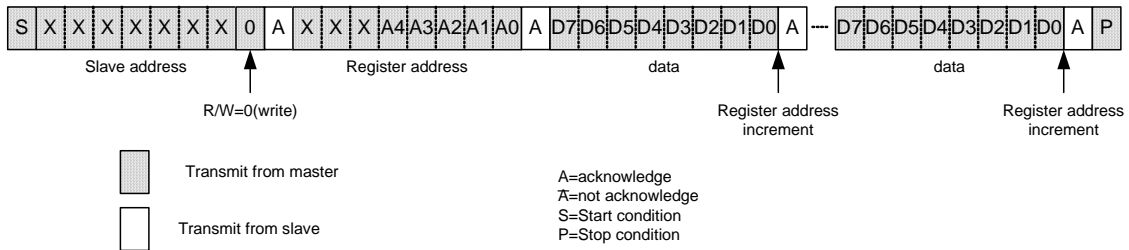

Fig.8 Writing protocol

2-6 Reading protocol

After Writing the slave address and Read/Write command bits, the next byte is read. The reading register address is next of previous accessed address. Therefore, the data is read with address increment. When the address is increased to the last, the following read address will be reset to (00h).

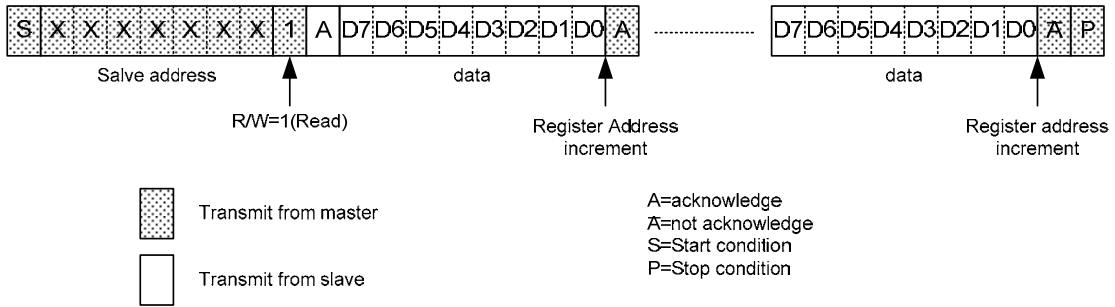

Fig.9 Readout protocol

2-7 Complex reading protocol

After the specifying the internal register address, a repeated START condition occurs and the direction of data transfer is changed then reading access is done. Therefore, the data is read followed by address increment. If the address is increased to the last, it will be reset to (00h).

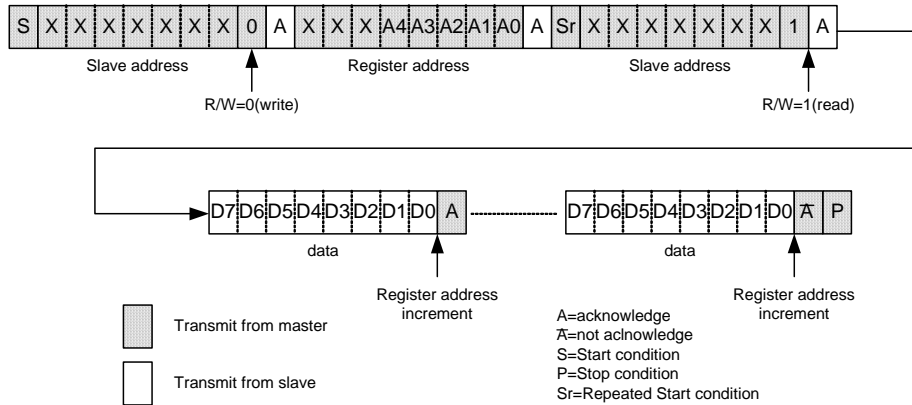

Fig.10 Complex reading protocol

2-8 Illegal access of I²C

The data accessed at that time is annulled, and access it again.

The illegal accesses are as follows.

- The START condition and the STOP condition are continuously generated.
- When the Slave address and the R/W bit is written, repeated START condition and the STOP condition are generated.
- Repeated START condition and the STOP condition are generated while writing data.

3. Register configuration

The address is increased one by one when data is continuously written.

When the final address is set to 13h, then the next address 00h will be written.

By making XRST "Low", the setting register value will be initialed shown in following register map.

3-1 Register map

Addr	Init	Type	D7	D6	D5	D4	D3	D2	D1	D0
00h	-	-	reserved	reserved	reserved	reserved	reserved	reserved	reserved	reserved
01h	-	-	reserved	reserved	reserved	reserved	reserved	reserved	reserved	reserved
02h	-	-	reserved	reserved	reserved	reserved	reserved	reserved	reserved	reserved
03h	-	-	reserved	reserved	reserved	reserved	reserved	reserved	reserved	reserved
04h	00h	R/W	RESET	reserved	reserved	reserved	reserved	reserved	reserved	reserved
05h	-	-	reserved	reserved	reserved	reserved	reserved	reserved	reserved	reserved
06h	-	-	reserved	reserved	reserved	reserved	reserved	reserved	reserved	reserved
07h	-	-	reserved	reserved	reserved	reserved	reserved	reserved	reserved	reserved
08h	00h	R/W	INTEN7	INTEN6	INTEN5	INTEN4	INTEN3	INTEN2	INTEN1	INTEN0
09h	-	-	reserved	reserved	reserved	reserved	reserved	reserved	reserved	reserved
0Ah	-	-	reserved	reserved	reserved	reserved	reserved	reserved	reserved	reserved
0Bh	-	-	reserved	reserved	reserved	reserved	reserved	reserved	reserved	reserved
0Ch	-	-	reserved	reserved	reserved	reserved	reserved	reserved	reserved	reserved
0Dh	-	-	reserved	reserved	reserved	reserved	reserved	reserved	reserved	reserved
0Eh	-	-	reserved	reserved	reserved	reserved	reserved	reserved	reserved	reserved
0Fh	-	-	reserved	reserved	reserved	reserved	reserved	reserved	reserved	reserved
10h	00h	R	GPI7	GPI6	GPI5	GPI4	GPI3	GPI2	GPI1	GPI0
11h	00h	R/W	GPO7	GPO6	GPO5	GPO4	GPO3	GPO2	GPO1	GPO0
12h	00h	R/W	WRSEL7	WRSEL6	WRSEL5	WRSEL4	WRSEL3	WRSEL2	WRSEL1	WRSEL0
13h	00h	R/W	XPD7	XPD6	XPD5	XPD4	XPD3	XPD2	XPD1	XPD0

※ Do not write reserved registers excluding "0". 10h address register is disregarded even if it is written.

3-2 Register function

※ n is the number of GPIO[7:0] ports.

Symbol	Addr	Description
RESET	04h	The register is returned to an initial value by writing "1". This register value is returned to "0". GPI _n register is not initialized.
INTEN _n	08h	Interrupt of GPIOn port is enabled by "1". It is masked by "0".
GPI _n	10h	Read GPIOn port. Writing is disregarded.
GPO _n	11h	Output value of GPIOn port.
WRSEL _n	12h	GPIOn port is input by "0" and output by "1".
XPD _n	13h	Pull-down of GPIOn port is on by "0" and off by "1". GPIOn should be input.

4. GPIO-Interrupt

4-1 GPIO configuration

As the default value, GPIO[7:0] ports are input and Pull-down.

At this time, WRSELn is "0" and XPDn is "0". (n is the number of GPIO[7:0] ports.)

Refer to the following for the configuration of GPIO.

State of GPIO	Register		
	GPOn	WRSELn	XPDn
Input, Pull-down ON	*	0	0
Input, Pull-down OFF	*	0	1
Output, H drive	1	1	*
Output, L drive	0	1	*
Output, Hi-Z -1※ ¹	0	0	1

※¹ Make external Pull-up the terminal potential which is the potential of V_{VDDIO} or more.

- About GPIO port not used
 When making it to the output, open it.
 When making it to the input, do not open it. It is forced by "0" or Pull-down on.
 When interrupt is enabled, mask INTEN register in which the port is not used to "0".

4-2 Interrupt configuration

When interrupt is generated, L is output from XINT port. The default value is Hi-Z. Make it Pull-up.

For the default value, interrupt is masked with INTEN register "0".

The bit to be used is made "1", and the mask is released. WRSEL register should be "0"(input).

4-3 Write to GPIO port

After setting the internal register address, the data from master is written from MSB.

After Acknowledge is returned, the value of each GPIO port will be changed.

When the register is written, Write Configuration Pulse is generated according to the timing of Acknowledge.

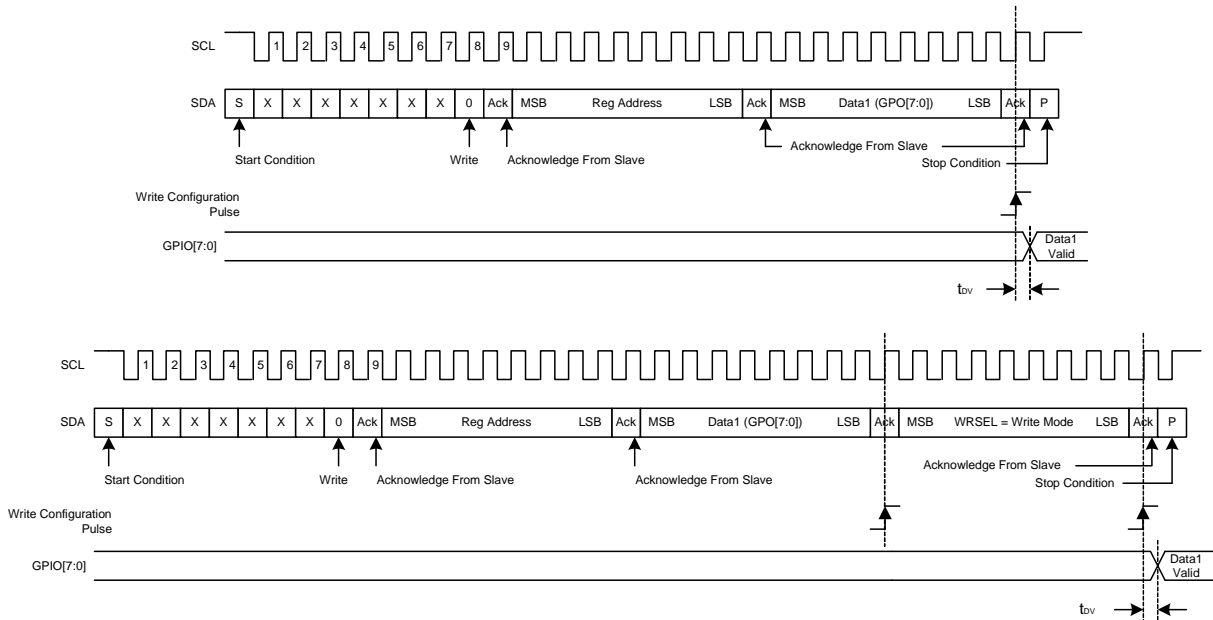

Fig.11 Write to GPIO port

4-4 Read from GPIO port

After writing of the Slave address and R/W bits, reading GPIO port is begun from the following byte.

The data that had been being fixed between the following Acknowledge after Acknowledge is taken into the GPI register, and it is transmitted to Master.

All ports that are the input by WRSEL register are read to the GPI register according to the timing of Read Configuration Pulse. Therefore, the data of each bit that SDA transmits is the GPI register value taken immediately before that.

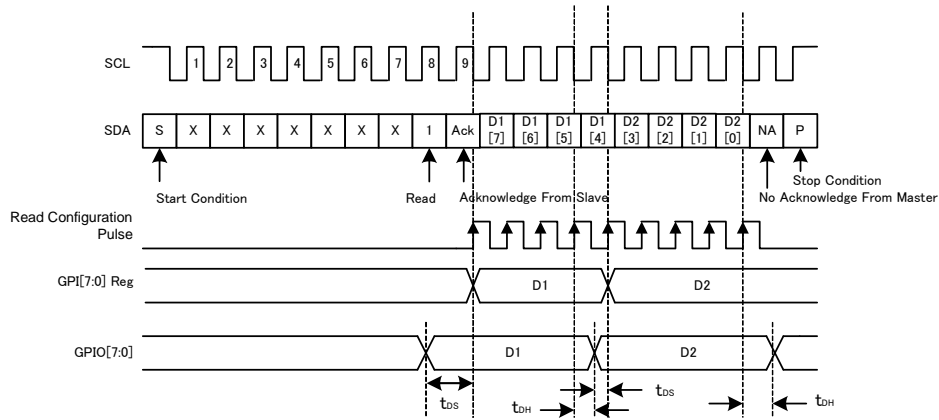

Fig.12 Read from GPIO port

4-5 Interrupt Valid/Reset

If GPIO port becomes different from the GPIIn register (default is "0"), XINT port is changed from "1" into "0".

It becomes "1" to release "0" of XINT port after acknowledge by reading GPI register. Because the value of GPIO port is reflected in the output as it is and is not latched, XINT becomes "1" again if the port returns to the same value.

If the ports with INTEN register "1" are different even by one, XINT becomes "0".

If it is distinguished which GPIO port changes, it is necessary to keep the GPI register value on the master side and compare with the value that is read after XINT is asserted.

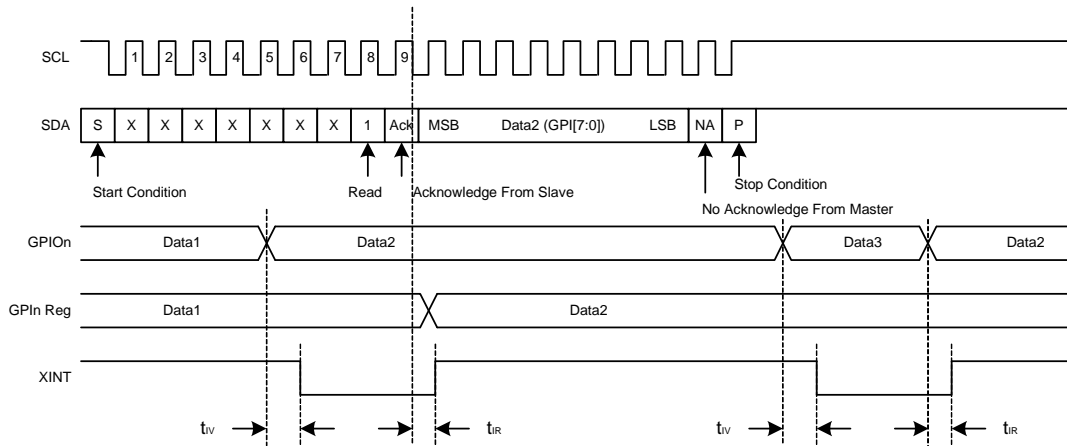

Fig.13 Interrupt Valid/Reset

●Electrical Specification

1. DC characteristics

 $V_{VDD}=1.8V$, $V_{VDDIO}=1.8V$, $T_{opr}=25^{\circ}C$

Parameter	Symbol	Specification			Unit	Conditions
		Min	Typ	Max		
Input H Voltage1	V_{IH1}	$0.7 \times V_{VDDIO}$	-	3.6	V	GPIO[7:0]
Input L Voltage1	V_{IL1}	-0.2	-	$0.3 \times V_{VDDIO}$	V	
Input H Voltage2	V_{IH2}	$0.7 \times V_{VDD}$	-	3.6	V	SCL, SDA,
Input L Voltage2	V_{IL2}	-0.2	-	$0.3 \times V_{VDD}$	V	SCL, SDA, XRST, ADR
Input H Voltage3	V_{IH3}	$0.7 \times V_{VDD}$	-	$V_{VDD}+0.2$	V	XRST, ADR
Input H Current1 (3V Tolerant)	I_{IH1}	-1	-	1	μA	$V_{IN}=3.6V^{*1}$
Input H Current2	I_{IH2}	-1	-	1	μA	$V_{IN}=1.8V$, XRST,ADR
Input L Current	I_{IL}	-1	-	1	μA	$V_{IN}=0V^{*1}$, XRST,ADR
Output H Voltage1	V_{OH1}	$0.75 \times V_{VDDIO}$	-	-	V	$I_{OH}=-2mA$, GPIO[7:0]
Output L Voltage1	V_{OL1}	-	-	$0.25 \times V_{VDDIO}$	V	$I_{OL}=2mA$, GPIO[7:0]
Output H Voltage2	V_{OH2}	$V_{VDDIO}-0.25$	-	-	V	$I_{OH}=-0.2mA$, GPIO[7:0]
Output L Voltage2	V_{OL2}	-	-	0.25	V	$I_{OL}=0.2mA$, GPIO[7:0]
Output L Voltage3	V_{OL3}	-	-	0.3	V	$I_{OL}=3mA$, SDA, XINT

*1 XINT(HI-Z), XRST, SCL, SDA(IN), ADR, GPIO[7:0](IN, Pull-down OFF)

2. Circuit Current

 $V_{VDD}=1.8V$, $V_{VDDIO}=1.8V$, $T_{opr}=25^{\circ}C$

Parameter	Symbol	Specification			Unit	Condition
		Min	Typ	Max		
Power Down Current (VDD)	I_{PD1}	-	-	1.0	μA	XRST=VSS
Power Down Current (VDDIO)	I_{PD2}	-	-	1.0	μA	
Standby Current (VDD)	I_{STBY1}	-	-	3.0	μA	XRST=VDD, SCL=VDD, SDA=VDD
Standby Current (VDDIO)	I_{STBY2}	-	-	1.0	μA	
Operating Current1 (VDD)	I_{OP1}	-	14	25	μA	I ² C 400kHz 100% traffic density ^{*1}
Operating Current1 (VDD)	I_{OP2}	-	2	8	μA	I ² C 400kHz 1% traffic density ^{*2}

*1 All GPIO ports are output, and they repeat 01010101 and 10101010.

*2 The period when I²C did not operate was inserted in *1 pattern by 99%.

3. I²C AC characteristics

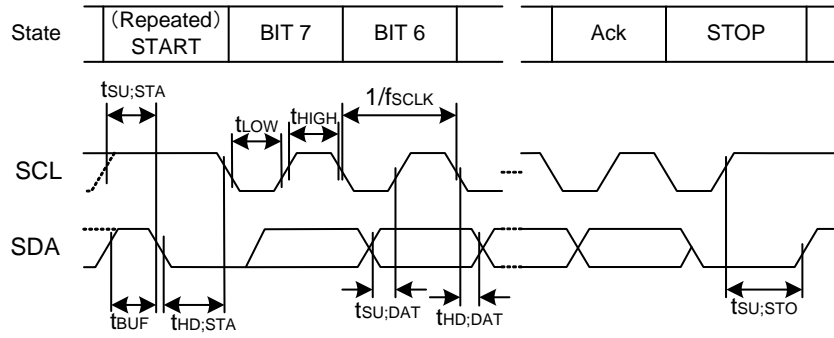

Fig.14 I²C AC Timing

$V_{VDD}=1.8V$, $V_{VDDIO}=1.8V$, $T_{opr}=25^{\circ}C$

Parameter	Symbol	Specification			Unit	Conditions
		Min	Typ	Max		
SCL Clock Frequency	f_{SCLK}	-	-	400	kHz	
Bus free time	t_{BUF}	1.3	-	-	μs	
(Repeated)START Condition Setup Time	$t_{SU;STA}$	0.6	-	-	μs	
(Repeated)START Condition Hold Time	$t_{HD;STA}$	0.6	-	-	μs	
SCL Low Time	t_{LOW}	1.3	-	-	μs	
SCL High Time	t_{HIGH}	0.6	-	-	μs	
Data Setup Time	$t_{SU;DAT}$	100	-	-	μs	
Data Hold Time	$t_{HD;DAT}$	0	-	-	ns	
STOP Condition Setup Time	$t_{SU;STO}$	0.6	-	-	μs	

4. GPIO AC Characteristics

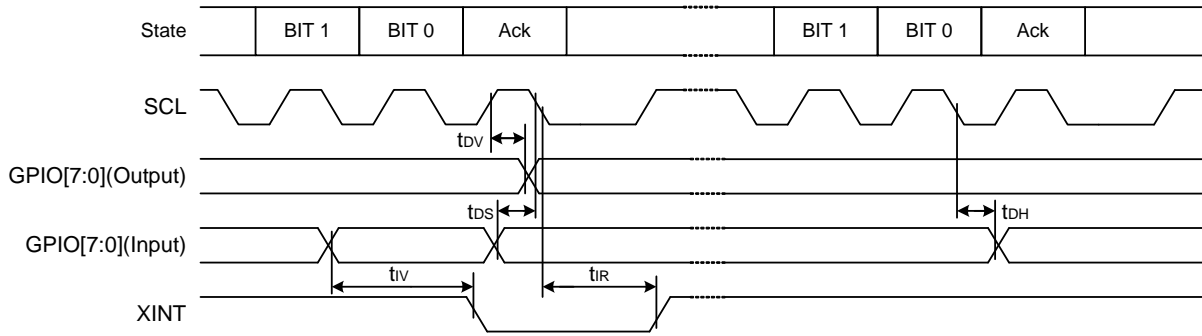

Fig.15 GPIO AC timing

V_{VDD}=1.8V, V_{VDDIO}=1.8V, Topr=25°C

Parameter	Symbol	Specification			Unit	Conditions
		Min	Typ	Max		
Output Data Valid Time	t _{DV}	-	-	0.8	μs	See Fig.11
Input Data Setup Time	t _{DS}	100	-	-	ns	See Fig.12
Input Data Hold Time	t _{DH}	0.8	-	-	μs	
Interrupt Valid Time	t _{IV}	-	-	5	μs	See Fig.13
Interrupt Reset Time	t _{IR}	-	-	5	μs	

5. Startup sequence

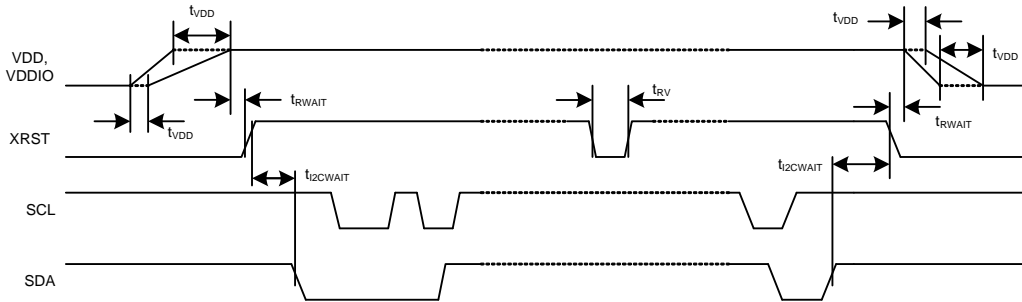

Fig.16 Start Sequence timing

V_{VDD}=1.8V, V_{VDDIO}=1.8V, T_{opr}=25°C

Parameter	Symbol	Specification			Unit	Conditions
		Min	Typ	Max		
VDD Stable Time	t _{VDD}	-	-	5	ms	VDD and VDDIO are ON at the same time.
Reset Wait Time	t _{RWAIT}	0	-	-	μs	XRST controlling *1
Reset Valid Time	t _{RV}	10	-	-	μs	
I ² C Wait Time	t _{I2CWAIT}	10	-	-	μs	

*1 Even if XRST port is not used, it operates because Power On Reset is built in. In this case, connect XRST port with VDD on the set PCB.

Note) At VDD=0V, when SCL port is changed from 0V to 0.5V or more, SCL port pulls the current. It is same in SDA, XINT, and GPIO[7:0] ports of 3V tolerant I/O. (VDDIO=0V in case of GPIO[7:0] ports)

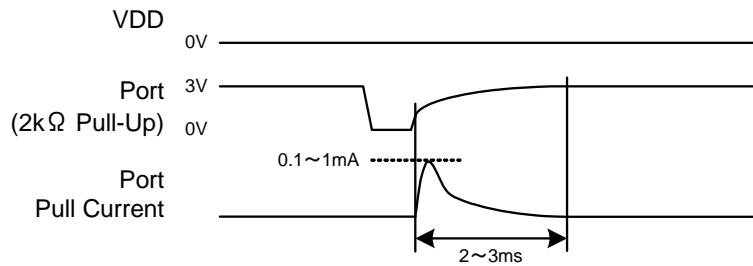

Fig.17 Port operating at VDD=0V

●Application circuit example

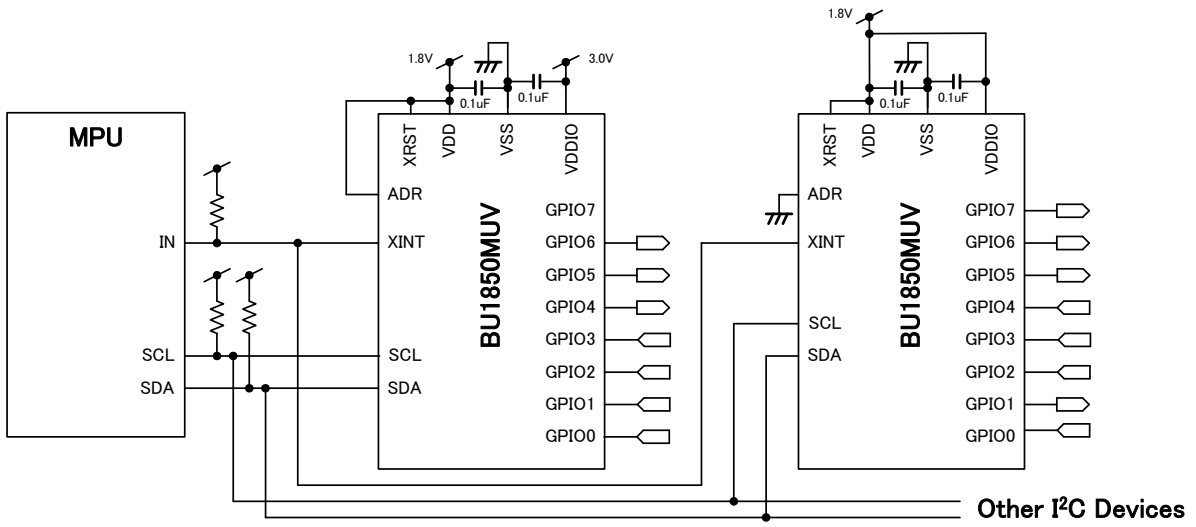

Fig.18 Application circuit example

●Ordering part number

B	U
---	---

Part No.

1	8	5	0
---	---	---	---

Part No.

M	U	V
---	---	---

Package
MUV:
VQFN016V3030

-	E	2
---	---	---

Packaging and forming specification
E2: Embossed tape and reel

VQFN016V3030

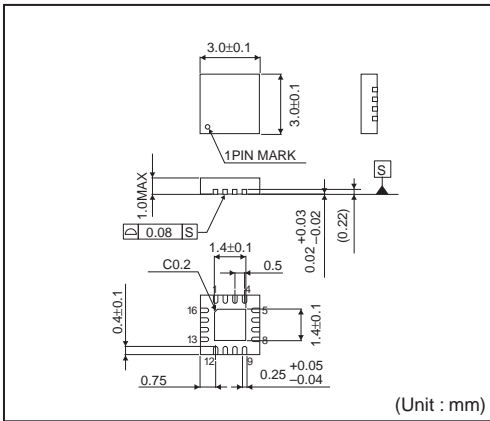

<Tape and Reel information>

Tape	Embossed carrier tape
Quantity	3000pcs
Direction of feed	E2 (The direction is the 1pin of product is at the upper left when you hold reel on the left hand and you pull out the tape on the right hand)

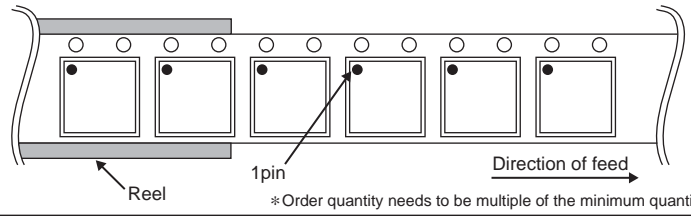

Notice

Precaution on using ROHM Products

- Our Products are designed and manufactured for application in ordinary electronic equipments (such as AV equipment, OA equipment, telecommunication equipment, home electronic appliances, amusement equipment, etc.). If you intend to use our Products in devices requiring extremely high reliability (such as medical equipment ^(Note 1), transport equipment, traffic equipment, aircraft/spacecraft, nuclear power controllers, fuel controllers, car equipment including car accessories, safety devices, etc.) and whose malfunction or failure may cause loss of human life, bodily injury or serious damage to property ("Specific Applications"), please consult with the ROHM sales representative in advance. Unless otherwise agreed in writing by ROHM in advance, ROHM shall not be in any way responsible or liable for any damages, expenses or losses incurred by you or third parties arising from the use of any ROHM's Products for Specific Applications.

(Note1) Medical Equipment Classification of the Specific Applications

JAPAN	USA	EU	CHINA
CLASS III	CLASS III	CLASS II b	CLASS III
CLASS IV		CLASS III	

- ROHM designs and manufactures its Products subject to strict quality control system. However, semiconductor products can fail or malfunction at a certain rate. Please be sure to implement, at your own responsibilities, adequate safety measures including but not limited to fail-safe design against the physical injury, damage to any property, which a failure or malfunction of our Products may cause. The following are examples of safety measures:
 - Installation of protection circuits or other protective devices to improve system safety
 - Installation of redundant circuits to reduce the impact of single or multiple circuit failure
- Our Products are designed and manufactured for use under standard conditions and not under any special or extraordinary environments or conditions, as exemplified below. Accordingly, ROHM shall not be in any way responsible or liable for any damages, expenses or losses arising from the use of any ROHM's Products under any special or extraordinary environments or conditions. If you intend to use our Products under any special or extraordinary environments or conditions (as exemplified below), your independent verification and confirmation of product performance, reliability, etc. prior to use, must be necessary:
 - Use of our Products in any types of liquid, including water, oils, chemicals, and organic solvents
 - Use of our Products outdoors or in places where the Products are exposed to direct sunlight or dust
 - Use of our Products in places where the Products are exposed to sea wind or corrosive gases, including Cl₂, H₂S, NH₃, SO₂, and NO₂
 - Use of our Products in places where the Products are exposed to static electricity or electromagnetic waves
 - Use of our Products in proximity to heat-producing components, plastic cords, or other flammable items
 - Sealing or coating our Products with resin or other coating materials
 - Use of our Products without cleaning residue of flux (even if you use no-clean type fluxes, cleaning residue of flux is recommended); or Washing our Products by using water or water-soluble cleaning agents for cleaning residue after soldering
 - Use of the Products in places subject to dew condensation
- The Products are not subject to radiation-proof design.
- Please verify and confirm characteristics of the final or mounted products in using the Products.
- In particular, if a transient load (a large amount of load applied in a short period of time, such as pulse. is applied, confirmation of performance characteristics after on-board mounting is strongly recommended. Avoid applying power exceeding normal rated power; exceeding the power rating under steady-state loading condition may negatively affect product performance and reliability.
- De-rate Power Dissipation (Pd) depending on Ambient temperature (Ta). When used in sealed area, confirm the actual ambient temperature.
- Confirm that operation temperature is within the specified range described in the product specification.
- ROHM shall not be in any way responsible or liable for failure induced under deviant condition from what is defined in this document.

Precaution for Mounting / Circuit board design

- When a highly active halogenous (chlorine, bromine, etc.) flux is used, the residue of flux may negatively affect product performance and reliability.
- In principle, the reflow soldering method must be used; if flow soldering method is preferred, please consult with the ROHM representative in advance.

For details, please refer to ROHM Mounting specification

Precautions Regarding Application Examples and External Circuits

1. If change is made to the constant of an external circuit, please allow a sufficient margin considering variations of the characteristics of the Products and external components, including transient characteristics, as well as static characteristics.
2. You agree that application notes, reference designs, and associated data and information contained in this document are presented only as guidance for Products use. Therefore, in case you use such information, you are solely responsible for it and you must exercise your own independent verification and judgment in the use of such information contained in this document. ROHM shall not be in any way responsible or liable for any damages, expenses or losses incurred by you or third parties arising from the use of such information.

Precaution for Electrostatic

This Product is electrostatic sensitive product, which may be damaged due to electrostatic discharge. Please take proper caution in your manufacturing process and storage so that voltage exceeding the Products maximum rating will not be applied to Products. Please take special care under dry condition (e.g. Grounding of human body / equipment / solder iron, isolation from charged objects, setting of Ionizer, friction prevention and temperature / humidity control).

Precaution for Storage / Transportation

1. Product performance and soldered connections may deteriorate if the Products are stored in the places where:
 - [a] the Products are exposed to sea winds or corrosive gases, including Cl₂, H₂S, NH₃, SO₂, and NO₂
 - [b] the temperature or humidity exceeds those recommended by ROHM
 - [c] the Products are exposed to direct sunshine or condensation
 - [d] the Products are exposed to high Electrostatic
2. Even under ROHM recommended storage condition, solderability of products out of recommended storage time period may be degraded. It is strongly recommended to confirm solderability before using Products of which storage time is exceeding the recommended storage time period.
3. Store / transport cartons in the correct direction, which is indicated on a carton with a symbol. Otherwise bent leads may occur due to excessive stress applied when dropping of a carton.
4. Use Products within the specified time after opening a humidity barrier bag. Baking is required before using Products of which storage time is exceeding the recommended storage time period.

Precaution for Product Label

QR code printed on ROHM Products label is for ROHM's internal use only.

Precaution for Disposition

When disposing Products please dispose them properly using an authorized industry waste company.

Precaution for Foreign Exchange and Foreign Trade act

Since our Products might fall under controlled goods prescribed by the applicable foreign exchange and foreign trade act, please consult with ROHM representative in case of export.

Precaution Regarding Intellectual Property Rights

1. All information and data including but not limited to application example contained in this document is for reference only. ROHM does not warrant that foregoing information or data will not infringe any intellectual property rights or any other rights of any third party regarding such information or data. ROHM shall not be in any way responsible or liable for infringement of any intellectual property rights or other damages arising from use of such information or data.:
2. No license, expressly or implied, is granted hereby under any intellectual property rights or other rights of ROHM or any third parties with respect to the information contained in this document.

Other Precaution

1. This document may not be reprinted or reproduced, in whole or in part, without prior written consent of ROHM.
2. The Products may not be disassembled, converted, modified, reproduced or otherwise changed without prior written consent of ROHM.
3. In no event shall you use in any way whatsoever the Products and the related technical information contained in the Products or this document for any military purposes, including but not limited to, the development of mass-destruction weapons.
4. The proper names of companies or products described in this document are trademarks or registered trademarks of ROHM, its affiliated companies or third parties.

General Precaution

1. Before you use our Products, you are requested to carefully read this document and fully understand its contents. ROHM shall not be in any way responsible or liable for failure, malfunction or accident arising from the use of any ROHM's Products against warning, caution or note contained in this document.
2. All information contained in this document is current as of the issuing date and subject to change without any prior notice. Before purchasing or using ROHM's Products, please confirm the latest information with a ROHM sales representative.
3. The information contained in this document is provided on an "as is" basis and ROHM does not warrant that all information contained in this document is accurate and/or error-free. ROHM shall not be in any way responsible or liable for any damages, expenses or losses incurred by you or third parties resulting from inaccuracy or errors of or concerning such information.

Компания «Life Electronics» занимается поставками электронных компонентов импортного и отечественного производства от производителей и со складов крупных дистрибьюторов Европы, Америки и Азии.

С конца 2013 года компания активно расширяет линейку поставок компонентов по направлению коаксиальный кабель, кварцевые генераторы и конденсаторы (керамические, пленочные, электролитические), за счёт заключения дистрибьюторских договоров

Мы предлагаем:

- Конкуренспособные цены и скидки постоянным клиентам.
- Специальные условия для постоянных клиентов.
- Подбор аналогов.
- Поставку компонентов в любых объемах, удовлетворяющих вашим потребностям.
- Приемлемые сроки поставки, возможна ускоренная поставка.
- Доставку товара в любую точку России и стран СНГ.
- Комплексную поставку.
- Работу по проектам и поставку образцов.
- Формирование склада под заказчика.
- Сертификаты соответствия на поставляемую продукцию (по желанию клиента).
- Тестирование поставляемой продукции.
- Поставку компонентов, требующих военную и космическую приемку.
- Входной контроль качества.
- Наличие сертификата ISO.

В составе нашей компании организован Конструкторский отдел, призванный помогать разработчикам, и инженерам.

Конструкторский отдел помогает осуществить:

- Регистрацию проекта у производителя компонентов.
- Техническую поддержку проекта.
- Защиту от снятия компонента с производства.
- Оценку стоимости проекта по компонентам.
- Изготовление тестовой платы монтаж и пусконаладочные работы.



Тел: +7 (812) 336 43 04 (многоканальный)
Email: org@lifeelectronics.ru