

CUSTOMER'S NAME

MOUSER ELECTRONICS

ALPHA REFERENCE NO.

SP16040218



SPECIFICATION

PART NO.	ALPHA MODEL NAME
	RV122F-20-15F-BXXK-0072
	BXXK for (B1~500K)

MODEL NAME

MODEL NO.

APPROVAL

PREPARED BY	REVIEWED BY	APPROVED BY
 2016.4.29 彩霞		 2016-4-29 延珍



台灣艾華電子工業股份有限公司

33045 桃園市桃園區中正路 1221 號 9 樓

TAIWAN ALPHA ELECTRONIC CO., LTD.

9F, No. 1221, Chung Cheng Rd., Taoyuan Dist., Taoyuan City, 330 Taiwan

Tel: 886-3-3577799 Fax: 886-3-3577700

EMAIL: sales@taiwanalpha.com.tw

URL: http://www.taiwanalpha.com

石碇福隆工業區艾華電子
 JUN 10, 2008
 收文日



SHAFT SHOWN IN FULL C.C.W. POSITION

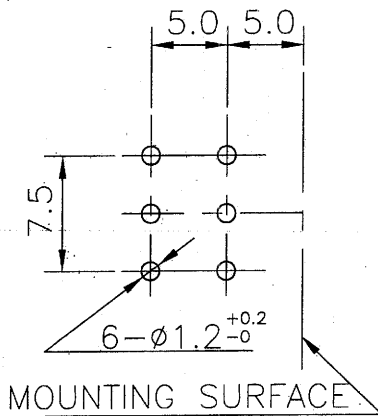
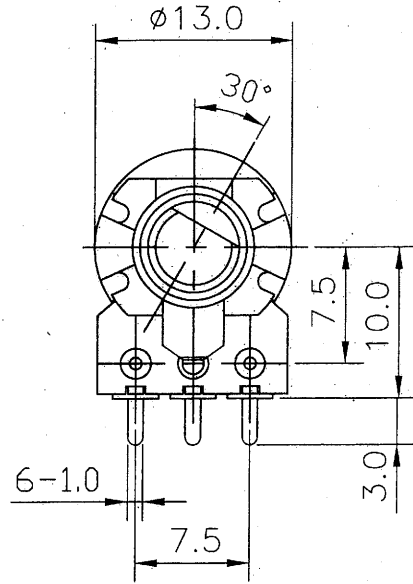
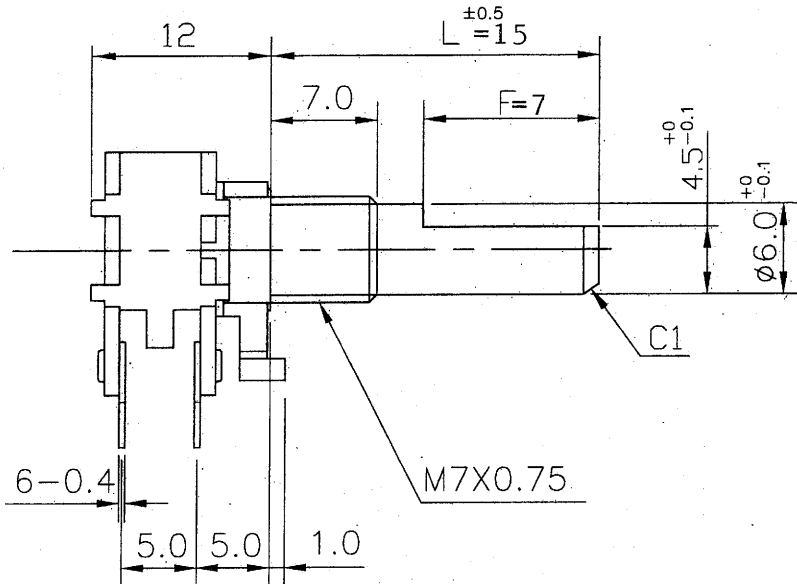

P.C.B. MOUNTING HOLE DETAIL

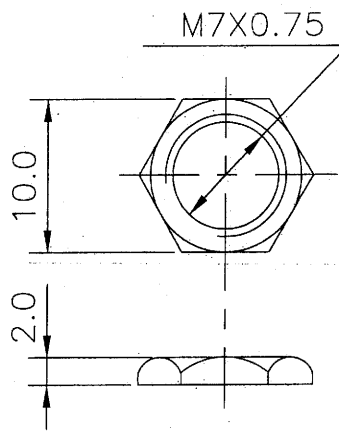

NUT 1PC

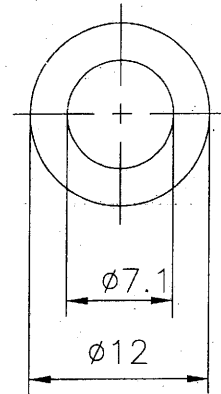

WASHER 1PC



				-0072			
				RV122F-20-(L)F-XXX			
No.	DATE	DESCRIPTION	PART No.	NAME			
TOL. UNLESS OTHERWISE STATED		DIMENSION	SCALE	DRAWN BY	CHECKED BY	APPROVED BY	DRAWING No.
less than	10	±0.3	2 1				
above	10~30	±0.5					
above	30~100	±1.0					
above		±5'					

12Ø 單軸多連迴轉型規格書

SPECIFICATIONS OF ROTARY POTENTIOMETER

一、電氣規格：

Electrical characteristics :

1.1 全阻值：阻值適用範圍：1 KΩ- 500 KΩ (容許差±20%)

Overall resistance range : 1 KΩ- 500 KΩ (Tolerance±20%)

1.2 額定功率：B特性 0.08W B特性以外 0.04W

Power rating : B Taper 0.08W Except B Taper 0.04W

1.3 阻抗變化特性 Taper :

阻抗變化 特性 Taper	測定角度 Test point	端子 1-2 間輸出電壓	V1-2	端子 2-3 間輸出電壓	V2-3
		端子 1-3 間輸入電壓	V1-3 (%)	端子 1-3 間輸入電壓	V1-3 (%)
A	150°	10-25			
B	150°	40-60			
C	150°			10-25	
D(10A)	150°	6-15			
X(10C)	150°			6-15	
K(25A)	150°	18-34			
E(25C)	150°			18-34	

1.4 殘留阻值：1-2 端子/2-3 端子同。

Residual resistance : 1-2/2-3 Same

公稱阻抗值(KΩ) Overall resistance(KΩ)	殘留阻值 (Ω) Residual resistance(Ω)	
$R \leq 10$	10 以下	10MAX
$10 < R \leq 250$	20 以下	20MAX
$250 < R \leq 500$	全阻值的 0.1% 以下 0.1% Max of total resistance	

1.5 轉動雜音：依 JIS 測定法 47mV 以下。

Rotation noise (Refer to JIS) : 47mV max.

1.6 絕緣阻抗：D.C 500V 主軸與端子絕緣阻抗須在 50MΩ 以上。

Insulation resistance : 50MΩ min. at D.C 500V between shaft and terminal.

1.7 耐電壓：A.C 500V 可耐 1 分鐘以上，軸與接頭之間不得有損傷或絕緣破壞之現象發生。

Dielectric test : Units shall be designed to withstand 500 volts between resistance elements and case for a period of one minute without damage or arcing.

1.8 最高使用電壓：A.C 100V. (A.C 專用)。

Maximum operating voltage : 100V A.C (A.C voltage only)

1.9 連動誤差：在前、後段的 1-3 端子間加 1KHZ, 2V 的電壓，以前段為基準,1-2 端子間的輸出測定

前段

-40~0dB 之間

後段誤差

在 ±3dB 以內

Tracking error : Apply 2V (1KHZ) across terminals 1 and 3 of the front and rear sections measure the output level across terminals 1 and 2 of the outer section is within 3dB of the inner section output level which is -40 to 0 dB.

12Ø 單軸多連迴轉型規格書

SPECIFICATIONS OF ROTARY POTENTIOMETER

二、機械規格：

Mechanical：

2.1 全迴轉角度：300±5度

Total rotation angle：300±5°

2.2 回轉轉矩：20~250gf-cm (迴轉速度 60度 / 1秒)

Rotation torque：20~250gf-cm. (Rotational speed 60° / 1 sec)

2.3 軸鬆動：固定腳銲錫後軸前端加上 250gf-cm 之力矩，於軸前端移動 0.8
xL/20mm P-P 以內。

Play of shaft：The resistor shall be mounted by soldering the mounting legs on the panel, and an end thrust of 250gf-cm at the end of the shaft shall be applied. Then the total play of the shaft shall not exceed 0.8xL/20mm P-P.

2.4 軸擠壓引張強度：在軸之方向加壓力或張力之靜負荷 10kgf, 10 秒鐘無異常。

Axis push-pull strength：No damages with an application of push or pull force 10kgf for 10 sec.

2.5 軸之迴轉止動強度：3kgf-cm 以上。

Shaft end stop strength：3kgf-cm min.

2.6 軸承螺絲固定強度：7kgf-cm 以上。

Bushing mount strength：7kgf-cm min.

2.7 端子強度：銲錫後, 不可發生顯著之鬆動接觸不良。

Resistance to soldering heat：After soldering, there shall be no evidence of poor contact between resistance element and terminals, or any physical damages as a result of the test.

2.8 CLICK 位置：150 ± 2.5°

POSITION OF CLICK：150 ± 2.5°

2.9 CLICK 脫出力：50~300gf-cm

TORQUE OF CLICK：50~300gf-cm

☆ (2.8, 2.9 僅適用於附 CLICK 時)

(2.8, 2.9 IS USED FOR CLICK ONLY)

三、耐久性：

Reliability test：

3.1 電阻體迴轉壽命特性：15,000 轉以上，壽命試驗後 200mV 以下。

Rotational life：15,000 cycles min. After life test：200mV max.

* (500Ω resistance shall be endurable with life test of more than 5,000 cycles.)

四、其它 NOTE

4.1 依照 J I S C - 6 4 4 3 普通級碳素系可變電阻器。

Meet or exceed J I S C - 6 4 4 3 Requirements.

可變電阻無鉛焊錫與保管條件共通規格書

Common Specification of Lead-Free Soldering and Storage conditions for Potentiometers

以下焊錫條件以可變電阻置於單層 1.6mm 厚度之印刷電路板上測試為基準。

The specification below is based on testing results of 1.6mm thickness single layer printed circuit board.

1. 手工焊錫條件：

For Manual Soldering：

1-1 操作溫度最高 350°C，操作時間 3 秒以內。

To be performed within 3 seconds at 350°C or below.

2. 自動或半自動機台焊錫條件：

For Automated or Semi-Automated Soldering Equipments:

2-1 使用發泡式且比重 0.82 以上的助焊劑，發泡高度以印刷電路板厚度一半為標準，且助劑不能流入可變電阻基板表面及印刷電路板表面。

Flux of 0.82 specific gravity, applied by foam fluxer, shall be used. Foam head shall be limited to the height which is half thickness of printed circuit board to be soldered. No flux should be allowed to run up onto resistive element board of potentiometer and the surface of printed circuit board.

2-2 預熱時間不超過兩分鐘，焊錫界面 (即印刷電路板底) 最高預熱溫度不超過 100°C。

Regarding preheating, the entire flow duration should not exceed 2 minutes, and soldering surface temperature (undersurface of PCB) shall be settled within 100°C.

2-3 焊錫過程機台設定溫度在 260°C 以下、4 秒以內。

Solder Dipping is to be performed within 4 seconds at 260°C or below.

3. 若回轉型電位器是塑膠軸且帶有檔位，請將主軸先調整至其中一個檔位或中心檔位上才可以進行焊錫作業。

For rotary potentiometer with plastic shaft which have centre detent or multiple detents, the shaft should be settled in relevant detent position prior to soldering process.

4. 手工焊錫、自動或半自動機台焊錫不得超過一回。

Regardless of soldering facility and method, solder dipping or solder smearing must not be carried out more than 1 time.

註：本項焊錫溫度條件不適用於回流焊接作業設備。

Remarks: This specification is not recommended for and applicable in reflow soldering.

焊錫注意事項：

Caution for soldering:

如圖所示，請避免 PCB 上層表面有焊錫

Please avoid soldering on upper surface of P.C.B. as shown.

5. 保管條件(Storage conditions):

產品需儲存在原始的包裝,以及保持常溫

常濕、避免陽光直射、遠離任何腐蝕性氣體。

產品需盡快完全地使用完,建議最慢不要超過

交貨後 6 個月。產品經拆封後,全部的數量都需迅速地使用完。

The products shall be stored in the original packaging and kept at room temperature and humidity, out of direct sunlight, and away from any and all corrosive gas. The products shall be completely used as soon as possible, but no longer than 6 months from the date of delivery. Once product packaging is opened, the complete quantity of such products shall be promptly used.

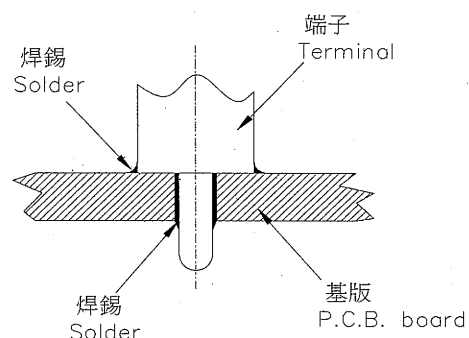

Компания «Life Electronics» занимается поставками электронных компонентов импортного и отечественного производства от производителей и со складов крупных дистрибьюторов Европы, Америки и Азии.

С конца 2013 года компания активно расширяет линейку поставок компонентов по направлению коаксиальный кабель, кварцевые генераторы и конденсаторы (керамические, пленочные, электролитические), за счёт заключения дистрибьюторских договоров

Мы предлагаем:

- Конкурентоспособные цены и скидки постоянным клиентам.
- Специальные условия для постоянных клиентов.
- Подбор аналогов.
- Поставку компонентов в любых объемах, удовлетворяющих вашим потребностям.
- Приемлемые сроки поставки, возможна ускоренная поставка.
- Доставку товара в любую точку России и стран СНГ.
- Комплексную поставку.
- Работу по проектам и поставку образцов.
- Формирование склада под заказчика.
- Сертификаты соответствия на поставляемую продукцию (по желанию клиента).
- Тестирование поставляемой продукции.
- Поставку компонентов, требующих военную и космическую приемку.
- Входной контроль качества.
- Наличие сертификата ISO.

В составе нашей компании организован Конструкторский отдел, призванный помогать разработчикам, и инженерам.

Конструкторский отдел помогает осуществить:

- Регистрацию проекта у производителя компонентов.
- Техническую поддержку проекта.
- Защиту от снятия компонента с производства.
- Оценку стоимости проекта по компонентам.
- Изготовление тестовой платы монтаж и пусконаладочные работы.



Тел: +7 (812) 336 43 04 (многоканальный)

Email: org@lifeelectronics.ru