

DA10-M Series

10 Watts

Data Sheet

Total Power: 10 Watts
Input Voltage: 90 - 264 Vac
of Outputs: Single, 5 Volts

SPECIAL FEATURES

- Medical and ITE safeties
- Switching wallmount power supply
- Available in interchangeable and fixed AC plug configurations
- CE Mark EMC, LVD & ErP 2011
- Universal AC input
- Fully regulated output
- Overvoltage, overcurrent, short circuit and overtemperature protection
- EU CoC v5 Tier 2 compliant
- Energy Star and CeC compliant
- Efficiency level VI
- RoHS compliant
- Constant current
- High MTBF
- Built in EMI filter (CISPR 32 Class B)

SAFETY

- UL 60950, 60601-1
- cUL 60950, 60601-1
- TUV 60950-1, 60601-1
- RCM AS/NZS 60950-1
- CB Certificate and report
- CE EMC, LVD, RoHS & ErP 2011 for MP, EU & UK versions
- PSE Denan 60950
- CCC <2000M, No Tropical
- Others NRCAN, DoE, CEC, AUGEMS

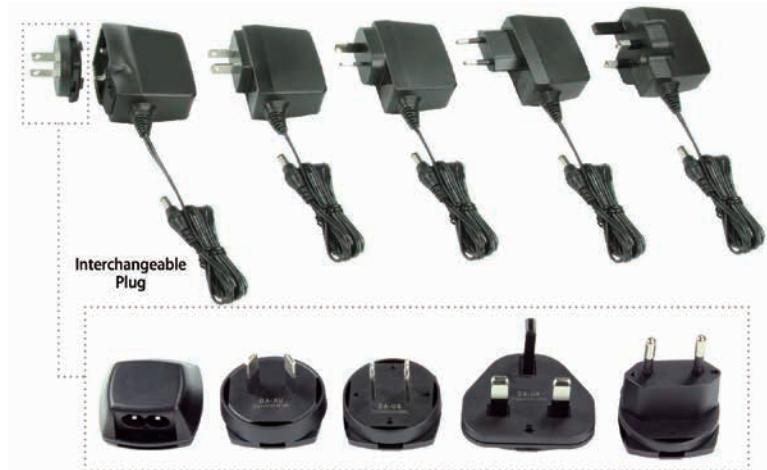

Electrical Specifications

Input	
Input range	90 - 264 Vac (wide range)
Frequency	47 - 63 Hz
Input current	0.25 A rms @ 120 Vac; 0.15 A @ 240 Vac
EMI/RFI	FCC Part 15, Subpart B Class B & EN55022 (CISPR 32) Class B
Safety ground leakage current	100 μ A @ 50/60 Hz, 264 Vac input
Output	
Voltage (Vo)	5.0 V
Voltage regulation	\pm 5%
Maximum Power (Po)	10 W
Hold-up time	10 ms. typical at full load @ 230 Vac
Overvoltage protection	Non-latching type
Overload protection	Output shortcircuit protection auto recover Overload protected @ 150% above maximum rating
Overtemperature protection	Recycle AC to reset
Output cable/connector/barrel polarity	DC cable with 2.5 mm x 5.5mm barrel plug, 2.1 mm x 5.5 mm available on DC multi-plug version. For others please contact factory. DC plug center +v DC plug outer -v

** DA10-M tested according to the medical standard IEC 60601-1-2 4th Edition.

Environmental Specifications

Operating temperature	-10 ° to +40 °C ambient
Storage temperature	-40 °C to +85 °C
Electromagnetic susceptibility	Designed to meet EN55024
Humidity	Operating; non-condensing 5% to 95% RH
Vibration	Frequency/PSD: 5 - 350 Hz 0.0001 g ² /Hz 350 - 500 Hz - 6dB/Oct. 500 Hz 0.00005 g ² /Hz Acceleration: 0.21 gRMS Duration: 20 min per second

AC Plug Configuration for Fixed Plug

U.S. 2-prong	US
Europe 2-prong	EU
United Kingdom 3-prong	UK
Australia 2-prong	AU

AC Plug Configuration for Interchangeable Plug

U.S. 2-prong	DA-US
Europe 2-prong	DA-EU
United Kingdom 3-prong	DA-UK
Australia 2-prong	DA-AU
C8 - 2 receptacle	DA-C8
Japan 2-prong	DA-JP
China 2-prong	DA-CH
Korea 2-prong	DA-KR

Mechanical Drawings

DA10-050US-M

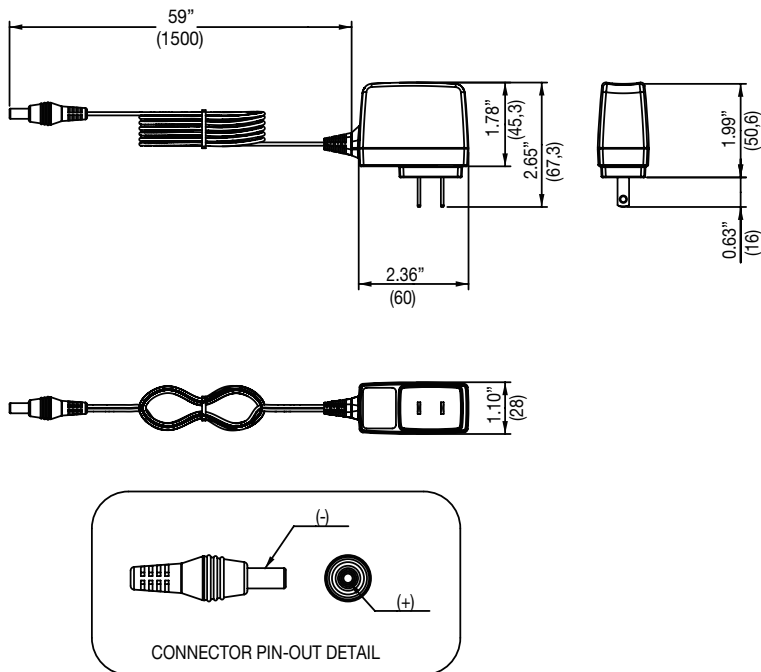

DA10-050AU-M

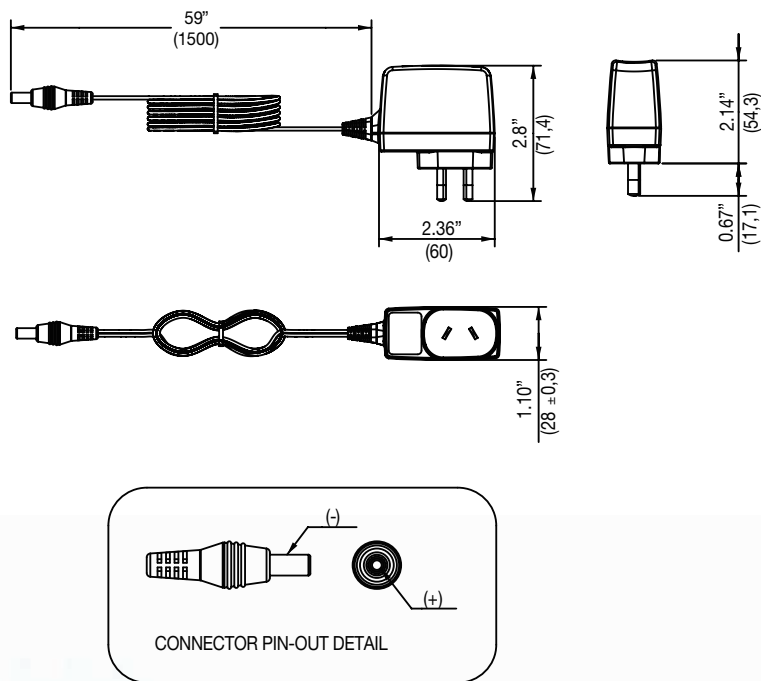

Mechanical Drawings

DA10-050EU-M

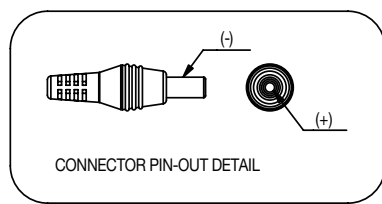
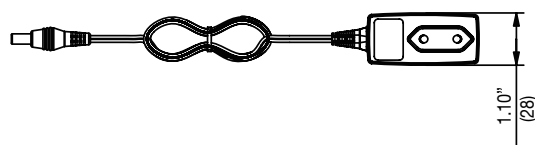
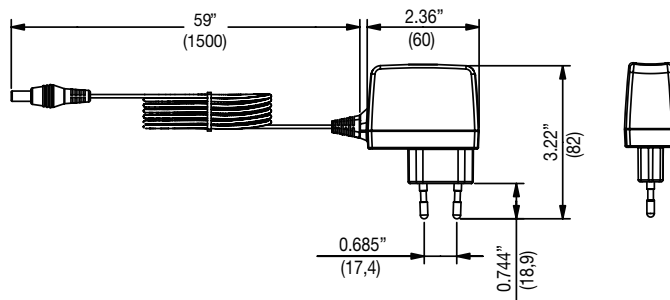

DA10-050UK-M

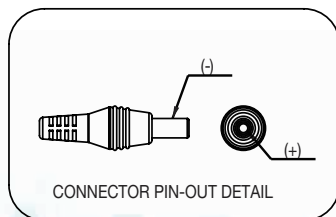
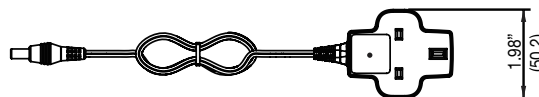
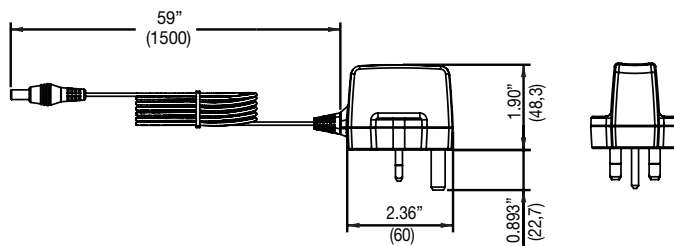

Mechanical Drawings

DA10-050MP-M and Plugs

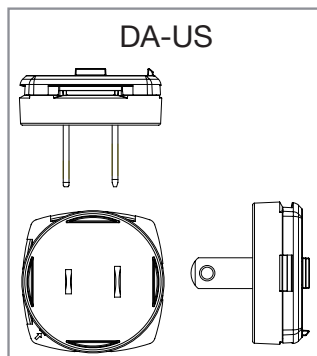
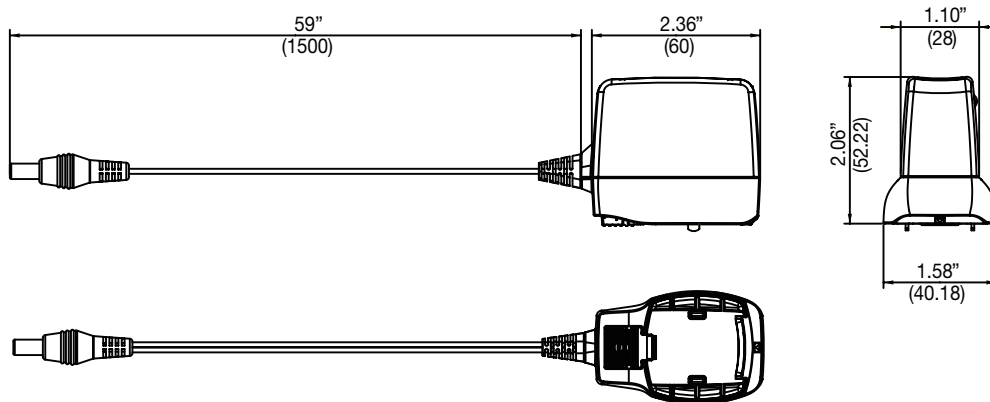

*Can be inserted straight or 90°

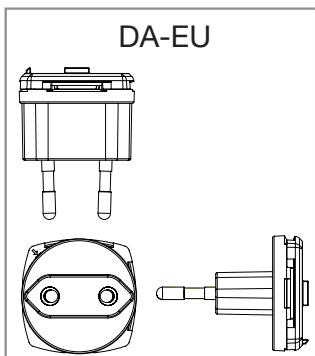
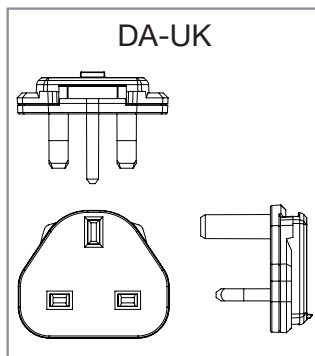

*Can be inserted straight or 90°

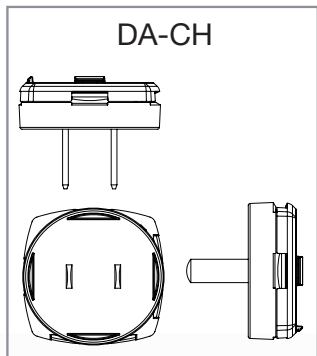
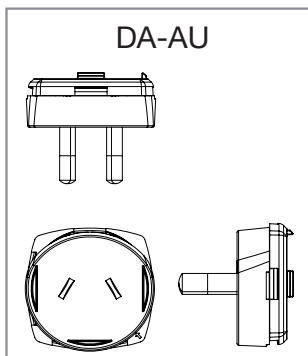

*Can be inserted straight or 90°

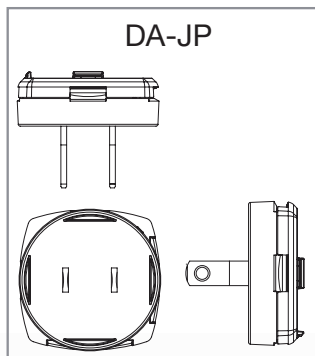

*Can be inserted straight or 90°

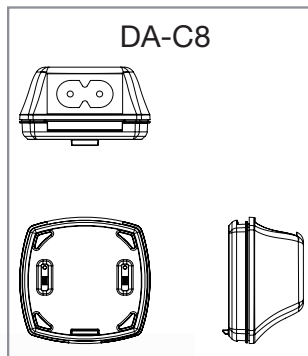
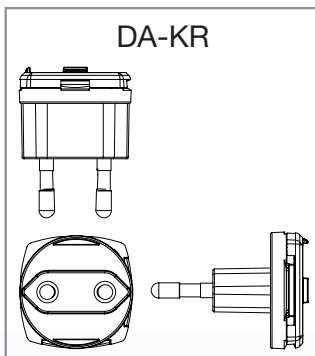

Notes:

1. Specifications subject to change without notice.
2. All dimensions in inches (mm), tolerance is $\pm .02$ ".
3. Weight: 0.25 lb/0.114 kg
4. Warranty: 2 years

Mechanical Drawings

DA10-050MP-M402

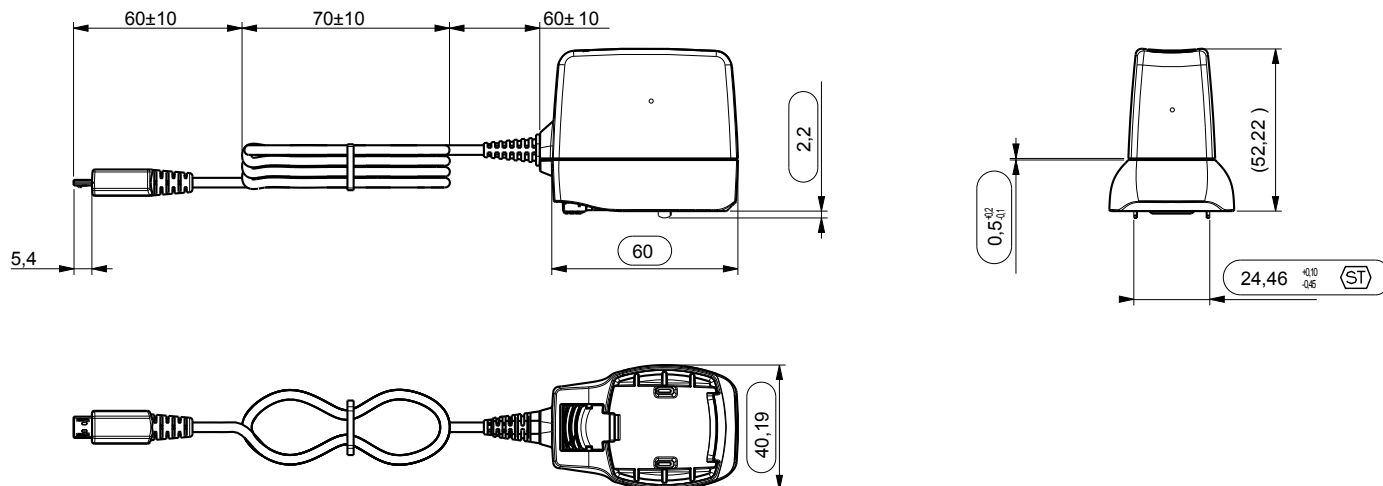

DA10-050MP-M2.1

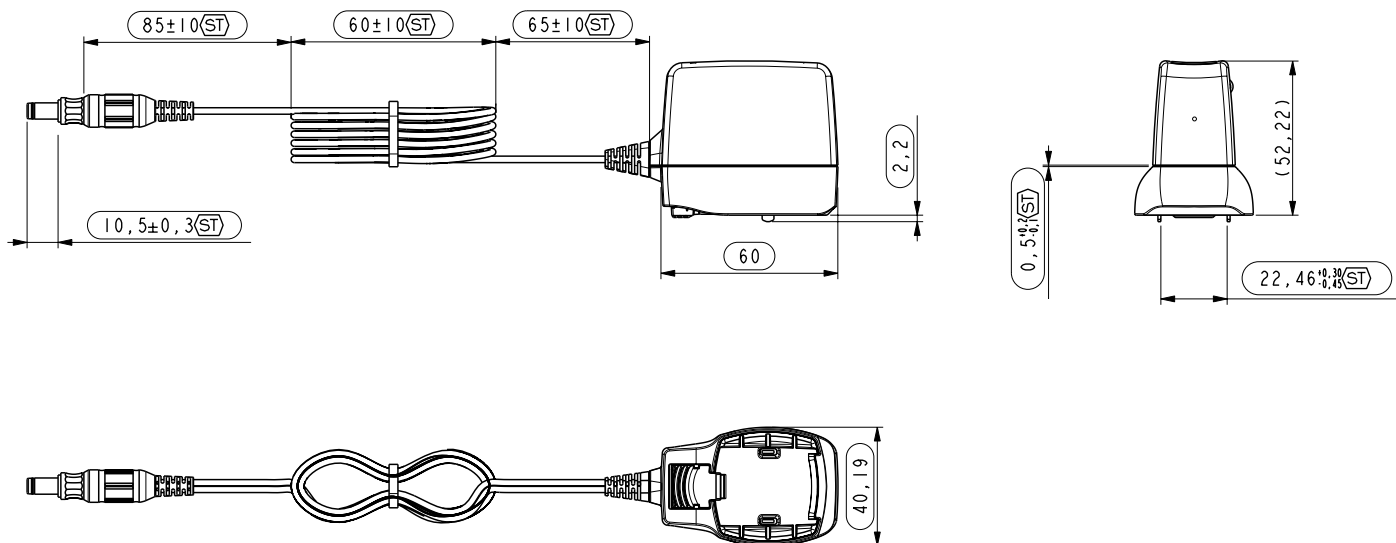

Notes:

1. Specifications subject to change without notice.
2. All dimensions in mm
3. Weight: 0.25 lb/0.114 kg
4. Warranty: 2 years

Ordering Information - DA10 Adapter

Model Number	Maximum Power	Output Voltage	Minimum Load	Maximum Load	Regulation ²	Ripple P/P (PARD) ³
DA10-050US-M	10 W	5.0 V	0 A	2.0 A	± 5%	< 100 mV
DA10-050EU-M	10 W	5.0 V	0 A	2.0 A	± 5%	< 100 mV
DA10-050UK-M	10 W	5.0 V	0 A	2.0 A	± 5%	< 100 mV
DA10-050AU-M	10 W	5.0 V	0 A	2.0 A	± 5%	< 100 mV
DA10-050MP-M*	10 W	5.0 V	0 A	2.0 A	± 5%	< 100 mV
DA10-050MP-M2.1**	10 W	5.0 V	0 A	2.0 A	± 5%	< 100 mV
DA10-050MP-M402***	10 W	5.0 V	0 A	2.0 A	± 5%	< 100 mV

* Interchangeable version - AC plugs must be purchased separately to be used with DA10-050MP-M.

** 2.1 mm x 5.5 mm barrel plug

*** Micro USB connector

Ordering Information - DA10 Interchangeable Plug

Model Number	
DA-US	DA-C8
DA-EU	DA-JP
DA-UK	DA-CH
DA-AU	DA-KR
DA-All (Includes DA-US, DA-EU, DA-UK, and DA-AU)	

1. Peak current lasting < 30 seconds with a maximum 10% duty cycle.
2. At 25 °C including initial tolerance, line voltage, load currents and output voltages adjusted to factory settings.
3. Peak-to-peak with 20 mHz bandwidth and 10 µF in parallel with a 0.1 µF capacitor at rated line voltage and load ranges.

WORLDWIDE OFFICES

Americas

2900 South Diablo Way
Suite B100
Tempe, AZ 85282, USA
+1 888 412 7832

Europe (UK)

Ground Floor Offices, Barberr House
4 Harbour Buildings, Waterfront West
Brierley Hill, West Midlands
DY5 1LN, UK
+44 (0) 1384 842 211

Asia (HK)

14/F, Lu Plaza
2 Wing Yip Street
Kwun Tong, Kowloon
Hong Kong
+852 2176 3333

ARTESYNTM
An Advanced Energy Company

www.artesyn.com

Artesyn Embedded Technologies, Artesyn Embedded Power, Artesyn, and all Artesyn related logos are trademarks and service marks of Artesyn Embedded Technologies, Inc. All other names and logos referred to are trade names, trademarks, or registered trademarks of their respective owners. Specifications are subject to change without notice. © 2019 Artesyn Embedded Technologies, Inc. All rights reserved. For full legal terms and conditions, please visit www.artesyn.com/legal.

For more information: www.artesyn.com
For support: productsupport.ep@artesyn.com

Компания «Life Electronics» занимается поставками электронных компонентов импортного и отечественного производства от производителей и со складов крупных дистрибьюторов Европы, Америки и Азии.

С конца 2013 года компания активно расширяет линейку поставок компонентов по направлению коаксиальный кабель, кварцевые генераторы и конденсаторы (керамические, пленочные, электролитические), за счёт заключения дистрибьюторских договоров

Мы предлагаем:

- Конкурентоспособные цены и скидки постоянным клиентам.
- Специальные условия для постоянных клиентов.
- Подбор аналогов.
- Поставку компонентов в любых объемах, удовлетворяющих вашим потребностям.
- Приемлемые сроки поставки, возможна ускоренная поставка.
- Доставку товара в любую точку России и стран СНГ.
- Комплексную поставку.
- Работу по проектам и поставку образцов.
- Формирование склада под заказчика.
- Сертификаты соответствия на поставляемую продукцию (по желанию клиента).
- Тестирование поставляемой продукции.
- Поставку компонентов, требующих военную и космическую приемку.
- Входной контроль качества.
- Наличие сертификата ISO.

В составе нашей компании организован Конструкторский отдел, призванный помогать разработчикам, и инженерам.

Конструкторский отдел помогает осуществить:

- Регистрацию проекта у производителя компонентов.
- Техническую поддержку проекта.
- Защиту от снятия компонента с производства.
- Оценку стоимости проекта по компонентам.
- Изготовление тестовой платы монтаж и пусконаладочные работы.

