

Description

The 8SLVD2102 is a high-performance differential dual 1:2 LVDS fanout buffer. The device is designed for the fanout of high-frequency, very low additive phase-noise clock and data signals. The 8SLVD2102 is characterized to operate from a 2.5V power supply. Guaranteed output-to-output and part-to-part skew characteristics make the 8SLVD2102 ideal for those clock distribution applications demanding well-defined performance and repeatability.

Two independent buffers with two low skew outputs each are available. The integrated bias voltage generators enables easy interfacing of single-ended signals to the device inputs. The device is optimized for low power consumption and low additive phase noise.

Features

- Two 1:2, low skew, low additive jitter LVDS fanout buffers
- Two differential clock inputs
- Differential pairs can accept the following differential input levels: LVDS and LVPECL
- Maximum input clock frequency: 2GHz
- Output bank skew: 15ps (maximum)
- Propagation delay: 300ps (maximum)
- Low additive phase jitter: 200fs, RMS (maximum); $f_{REF} = 156.25\text{MHz}$, $V_{PP} = 1\text{V}$, $V_{CMR} = 1\text{V}$, Integration Range 10kHz - 20MHz
- 2.5V supply voltage
- Maximum device current consumption (I_{DD}): 90mA
- Lead-free (RoHS 6) 16-Lead VFQFPN package
- -40°C to 85°C ambient operating temperature

Block Diagram

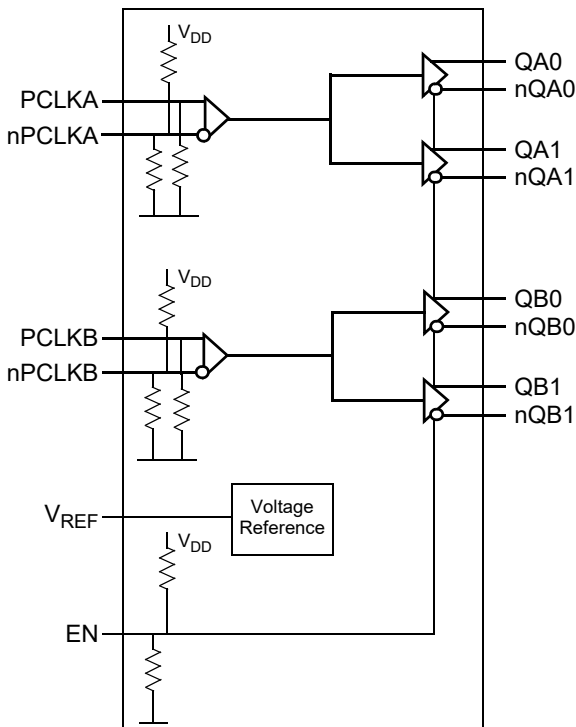

Pin Assignment

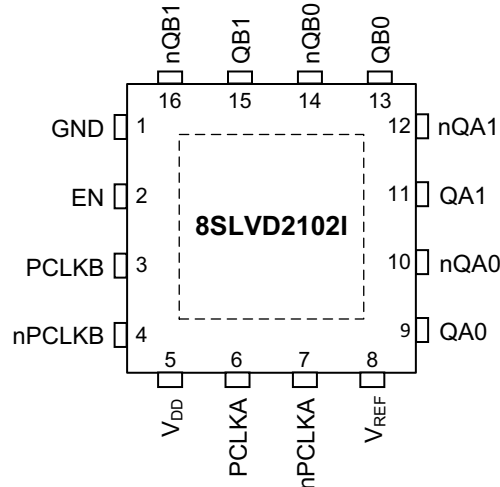

16-pin, 3.0 x 3.0 mm VFQFPN Package

Pin Description and Pin Characteristic Tables

Table 1. Pin Descriptions

| Number | Name | Type | | Description |
|--------|-----------|--------|---------------------|---|
| 1 | GND | Power | | Power supply ground. |
| 2 | EN | Input | Pullup/ Pulldown | Output enable pin. |
| 3 | PCLKB | Input | Pulldown | Non-inverting differential clock/data input. |
| 4 | nPCLKB | Input | Pullup/ Pulldown | Inverting differential clock/data input. $V_{DD}/2$ default when left floating. |
| 5 | V_{DD} | Power | | Power supply pin. |
| 6 | PCLKA | Input | Pulldown | Non-inverting differential clock/data input. |
| 7 | nPCLKA | Input | Pullup/ Pulldown | Inverting differential clock/data input. $V_{DD}/2$ default when left floating. |
| 8 | V_{REF} | Output | | Bias voltage reference for the PCLKx, nPCLKx inputs. |
| 9, 10 | QA0, nQA0 | Output | | Differential output pair. LVDS interface levels. |
| 11, 12 | QA1, nQA1 | Output | | Differential output pair. LVDS interface levels. |
| 13, 14 | QB0, nQB0 | Output | | Differential output pair. LVDS interface levels. |
| 15, 16 | QB1, nQB1 | Output | | Differential output pair. LVDS interface levels. |

NOTE: *Pulldown* and *Pullup* refer to internal input resistors. See Table 2, *Pin Characteristics*, for typical values.

Table 2. Pin Characteristics

| Symbol | Parameter | | Test Conditions | Minimum | Typical | Maximum | Units |
|----------------|-------------------------|-------------|-----------------|---------|---------|---------|-----------|
| C_{IN} | Input Capacitance | | | | 2 | | pF |
| $R_{PULLDOWN}$ | Input Pulldown Resistor | PCLK inputs | | | 51 | | $k\Omega$ |
| R_{PULLUP} | Input Pullup Resistor | PCLK inputs | | | 51 | | $k\Omega$ |
| $R_{PULLDOWN}$ | Input Pulldown Resistor | EN input | | | 51 | | $k\Omega$ |
| R_{PULLUP} | Input Pullup Resistor | EN input | | | 51 | | $k\Omega$ |

Table 3. EN Input Selection Function Table

| Input | Operation |
|----------|---|
| 0 (Low) | Outputs are disabled and outputs are static at $Qx = 0$ (low level) and $nQx = 1$ (high level). |
| 1 (High) | Bank A outputs are enabled and Bank B outputs are disabled at the following static levels: $QBx = 0$ (low level) and $nQBx = 1$ (high level). |
| Open | All outputs enabled. |

NOTE: EN is an asynchronous control.

Absolute Maximum Ratings

NOTE: Stresses beyond those listed under *Absolute Maximum Ratings* may cause permanent damage to the device. These ratings are stress specifications only. Functional operation of the product at these conditions or any conditions beyond those listed in the *DC Characteristics* or *AC Characteristics* is not implied. Exposure to absolute maximum rating conditions for extended periods may affect product reliability.

| Item | Rating |
|--|--------------------------|
| Supply Voltage, V_{DD} | 4.6V |
| Inputs, V_I | -0.5V to $V_{DD} + 0.5V$ |
| Outputs, I_O (LVDS) Continuous Current Surge Current | 10mA 15mA |
| Maximum Junction Temperature, $T_{J,MAX}$ | 125°C |
| Storage Temperature, T_{STG} | -65°C to 150°C |
| ESD - Human Body Model; NOTE 1 | 2000V |
| ESD - Charged Device Model; NOTE 1 | 1500V |

NOTE 1: According to JEDEC/JESD JS-001-2012/22-C101E.

DC Electrical Characteristics

Table 4A. Power Supply DC Characteristics, $V_{DD} = 2.5V \pm 5\%$, $T_A = -40^\circ C$ to $85^\circ C$

| Symbol | Parameter | Test Conditions | Minimum | Typical | Maximum | Units |
|----------|----------------------|--|---------|---------|---------|-------|
| V_{DD} | Power Supply Voltage | | 2.375 | 2.5 | 2.625 | V |
| I_{DD} | Power Supply Current | All outputs terminated 100Ω between nQx, Qx | | 80 | 90 | mA |

Table 4B. Output Enable (EN) Input DC Characteristics, $V_{DD} = 2.5V \pm 5\%$, $T_A = -40^\circ C$ to $85^\circ C$

| Symbol | Parameter | Test Conditions | Minimum | Typical | Maximum | Units |
|-----------|--------------------------|--------------------------------|----------------|--------------|----------------|-------|
| V_{MID} | Input Voltage - Open Pin | Open | | $V_{DD} / 2$ | | V |
| V_{IH} | Input High Voltage | | $0.8 * V_{DD}$ | | $V_{DD} + 0.3$ | V |
| V_{IL} | Input Low Voltage | | -0.3 | | $0.2 * V_{DD}$ | V |
| I_{IH} | Input High Current | $V_{DD} = V_{IN} = 2.625V$ | | | 150 | μA |
| I_{IL} | Input Low Current | $V_{DD} = 2.625V, V_{IN} = 0V$ | -150 | | | μA |

Table 4C. Differential Input Characteristics, $V_{DD} = 2.5V \pm 5\%$, $T_A = -40^\circ\text{C}$ to 85°C

| Symbol | Parameter | Test Conditions | Minimum | Typical | Maximum | Units |
|---------------|---|--|---------|---------|---------------------|---------------|
| I_{IH} | Input High Current | PCLKA, nPCLKA PCLKB, nPCLKB $V_{DD} = V_{IN} = 2.625V$ | | | 150 | μA |
| I_{IL} | Input Low Current | PCLKA, PCLKB $V_{DD} = 2.625V, V_{IN} = 0V$ | -10 | | | μA |
| | | nPCLKA, nPCLKB $V_{DD} = 2.625V, V_{IN} = 0V$ | -150 | | | μA |
| V_{REF_AC} | Reference Voltage for Input Bias | $V_{DD} = 2.5V, I_{REF} = +100\mu\text{A}$ | 1.00 | | 1.35 | V |
| V_{PP} | Peak-to-Peak Voltage; NOTE 1 | $f_{REF} < 1.5\text{ GHz}$ | 0.15 | | 1.6 | V |
| | | $f_{REF} > 1.5\text{ GHz}$ | 0.2 | | 1.6 | V |
| V_{CMR} | Common Mode Input Voltage; NOTE 1, 2 | | 1 | | $V_{DD} - V_{PP}/2$ | V |

NOTE 1: V_{IL} should not be less than $-0.3V$. V_{IH} should be less than V_{DD} .

NOTE 2: Common mode input voltage is defined at the crosspoint.

Table 4D. LVDS Output DC Characteristics, $V_{DD} = 2.5V \pm 5\%$, $T_A = -40^\circ\text{C}$ to 85°C

| Symbol | Parameter | Test Conditions | Minimum | Typical | Maximum | Units |
|-----------------|-----------------------------|---|---------|---------|---------|-------|
| V_{OD} | Differential Output Voltage | 100Ω termination between nQx, Qx | 247 | | 454 | mV |
| ΔV_{OD} | V_{OD} Magnitude Change | 100Ω termination between nQx, Qx | | | 50 | mV |
| V_{OS} | Offset Voltage | 100Ω termination between nQx, Qx | 1.0 | | 1.4 | V |
| ΔV_{OS} | V_{OS} Magnitude Change | 100Ω termination between nQx, Qx | | | 50 | mV |

Table 5. AC Electrical Characteristics, $V_{DD} = 2.5V \pm 5\%$, $T_A = -40^{\circ}C$ to $85^{\circ}C$

| Symbol | Parameter | Test Conditions | Minimum | Typical | Maximum | Units |
|---------------------|---|--|---------|---------|---------|-------|
| f_{REF} | Input Frequency | | | | 2 | GHz |
| $\Delta V/\Delta t$ | Input Edge Rate | | 0.75 | | | V/ns |
| t_{PD} | Propagation Delay; NOTE 1 | PCLKA, nPCLKA to QA[0:1], nQA[0:1], PCLKB, nPCLKB to QB[0:1], nQB[0:1] | 100 | 196 | 300 | ps |
| | Channel Isolation | | | 75 | | dB |
| $t_{sk(o)}$ | Output Skew; NOTE 2, 3 | QA[0:1], nQA[0:1], QB[0:1], nQB[0:1] | | 14 | 40 | ps |
| $t_{sk(b)}$ | Output Bank Skew; NOTE 3 | Between Outputs within Each Bank | | 7 | 15 | ps |
| $t_{sk(p)}$ | Pulse Skew | 50% Input Duty Cycle, $f_{REF} = 100MHz$ | -50 | | 50 | ps |
| $t_{sk(pp)}$ | Part-to-Part Skew; NOTE 3, 4 | | | | 200 | ps |
| t_{JIT} | Buffer Additive Phase Jitter, RMS; refer to Additive Phase Jitter Section | $f_{REF} = 1228.8MHz$, $V_{PP} = 0.2V$, $V_{CMR} = 1V$ Integration Range: 10kHz – 20MHz | | 20 | 50 | fs |
| | | $f_{REF} = 156.25MHz$, $V_{PP} = 0.5V$, $V_{CMR} = 1V$ Integration Range: 10kHz – 20MHz | | 140 | 250 | fs |
| | | $f_{REF} = 156.25MHz$, $V_{PP} = 1V$, $V_{CMR} = 1V$ Integration Range: 10kHz – 20MHz | | 80 | 200 | fs |
| $t_{JIT, SP}$ | Spurious Suppression, Coupling from QA1 to QB0 | $f_{QB0} = 500MHz$, $V_{PP(PCLKB)} = 0.15V$, $V_{CMR(PCLKB)} = 1V$ and $f_{QA1} = 62.5MHz$, $V_{PP(PCLKA)} = 1V$, $V_{CMR(PCLKA)} = 1V$ | | 68 | | dB |
| | | $f_{QB0} = 500MHz$, $V_{PP(PCLKB)} = 0.15V$, $V_{CMR(PCLKB)} = 1V$ and $f_{QA1} = 15.625MHz$, $V_{PP(PCLKA)} = 1V$, $V_{CMR(PCLKA)} = 1V$ | | 74 | | dB |
| t_R / t_F | Output Rise/ Fall Time | 20% to 80% | | 120 | 200 | ps |

NOTE: Electrical parameters are guaranteed over the specified ambient operating temperature range, which is established when the device is mounted in a test socket with maintained transverse airflow greater than 500 lfm. The device will meet specifications after thermal equilibrium has been reached under these conditions.

NOTE 1: Measured from the differential input crossing point to the differential output crossing point.

NOTE 2: Defined as skew between outputs at the same supply voltage and with equal load conditions.

Measured at the differential cross points.

NOTE 3: This parameter is defined in accordance with JEDEC Standard 65.

NOTE 4: Defined as skew between outputs on different devices operating at the same supply voltages and with equal load conditions. Using the same type of inputs on each device, the outputs are measured at the differential cross points.

Additive Phase Jitter

The spectral purity in a band at a specific offset from the fundamental compared to the power of the fundamental is called the **dBc Phase Noise**. This value is normally expressed using a Phase noise plot and is most often the specified plot in many applications. Phase noise is defined as the ratio of the noise power present in a 1Hz band at a specified offset from the fundamental frequency to the power value of the fundamental. This ratio is expressed in decibels (dBm) or a ratio

of the power in the 1Hz band to the power in the fundamental. When the required offset is specified, the phase noise is called a **dBc** value, which simply means dBm at a specified offset from the fundamental. By investigating jitter in the frequency domain, we get a better understanding of its effects on the desired application over the entire time record of the signal. It is mathematically possible to calculate an expected bit error rate given a phase noise plot.

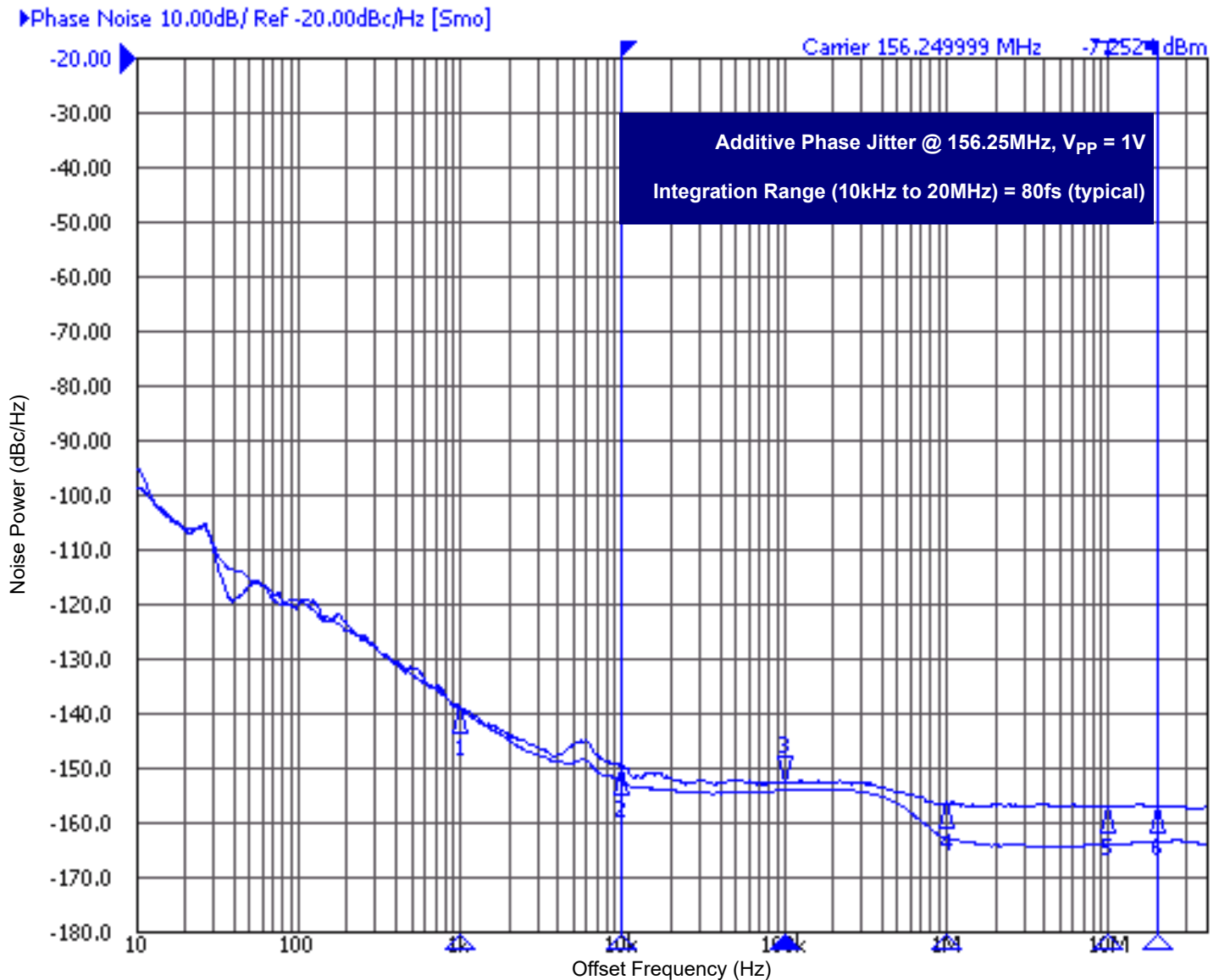

As with most timing specifications, phase noise measurements have issues relating to the limitations of the measurement equipment. The noise floor of the equipment can be higher or lower than the noise floor of the device. Additive phase noise is dependent on both the noise floor of the input source and measurement equipment.

Measured using a Rohde & Schwarz SMA100 as the input source.

Parameter Measurement Information

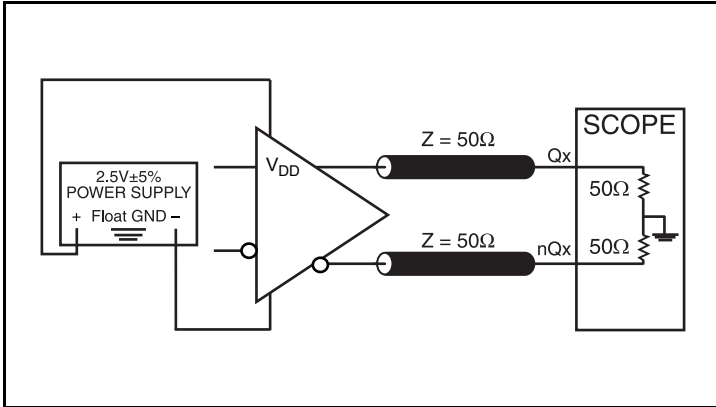

LVDS Output Load Test Circuit

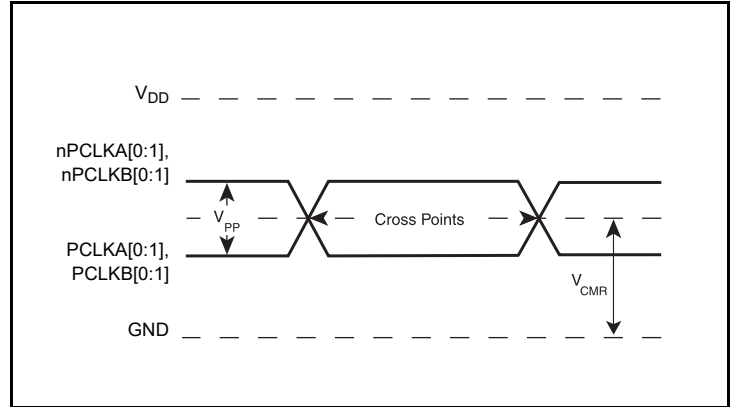

Differential Input Level

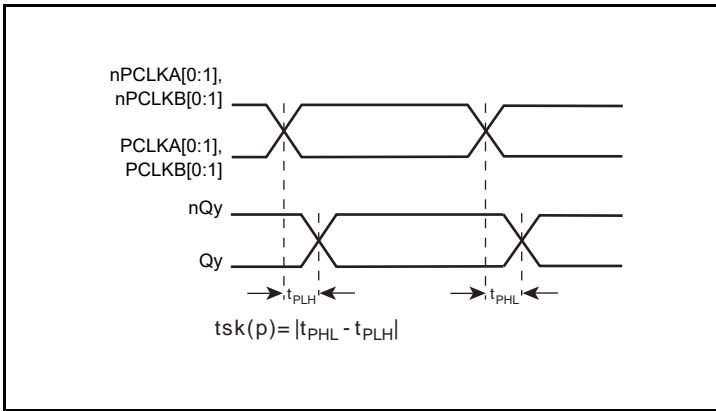

Pulse Skew

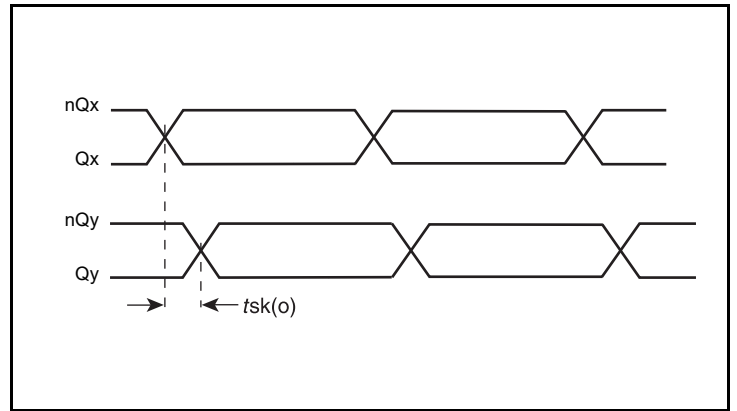

Output Skew

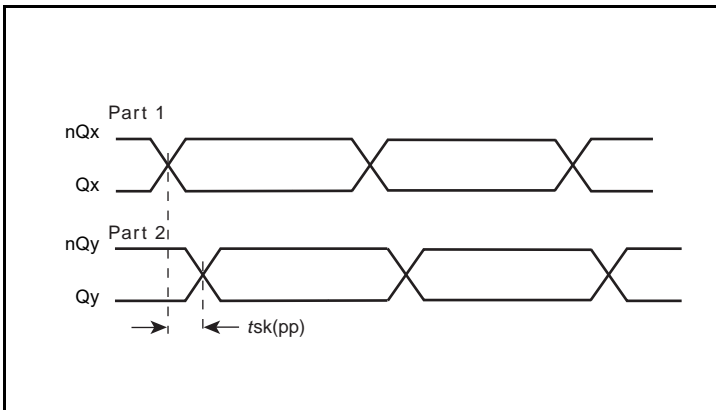

Part-to-Part Skew

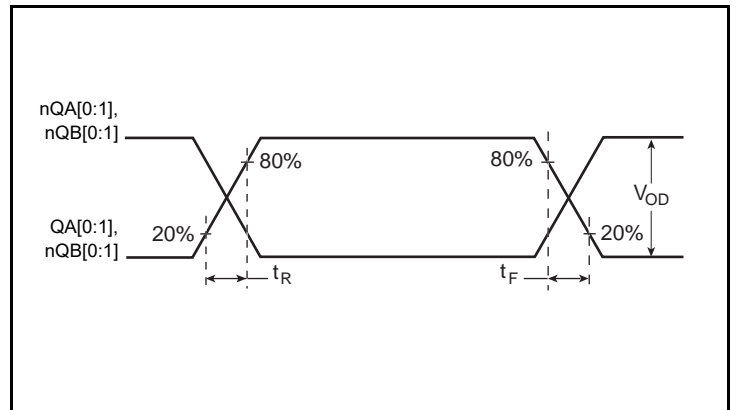

Output Rise/Fall Time

Parameter Measurement Information, continued

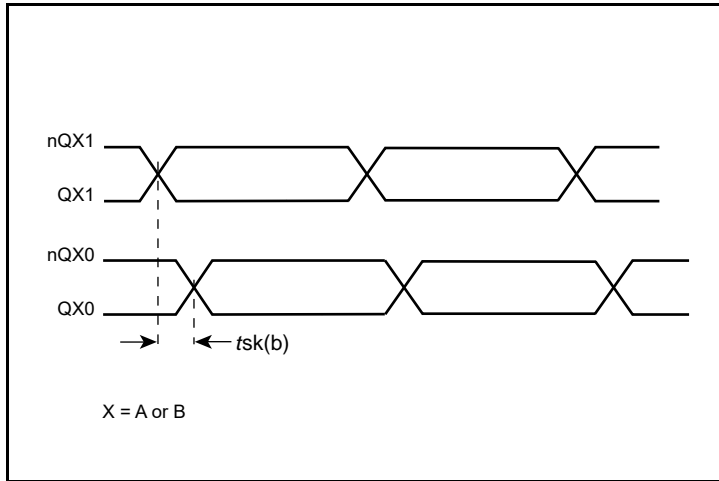

Bank Skew

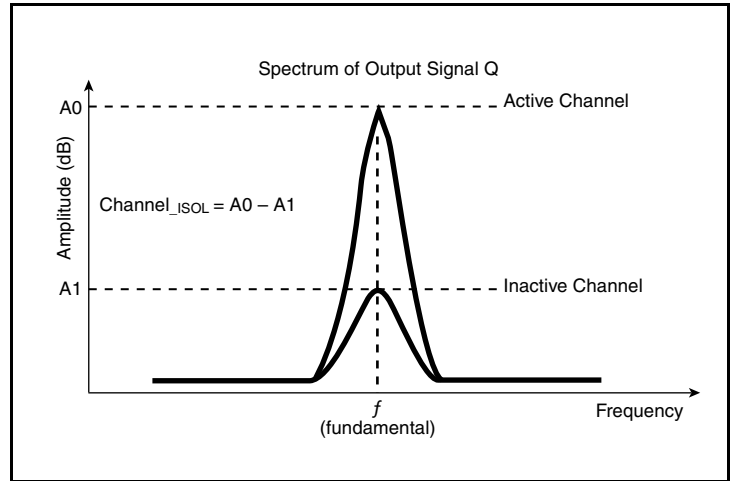

Channel Isolation

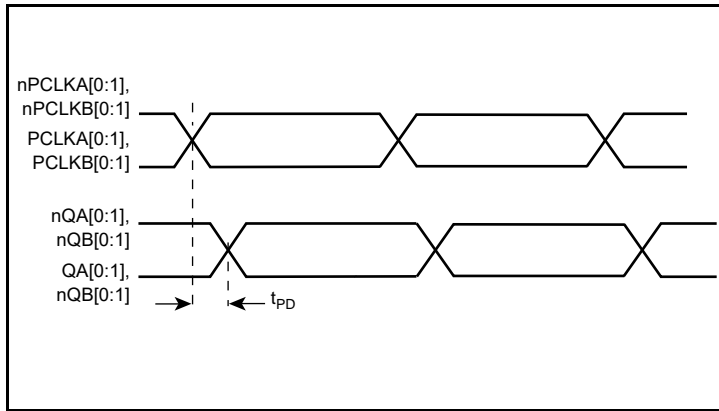

Propagation Delay

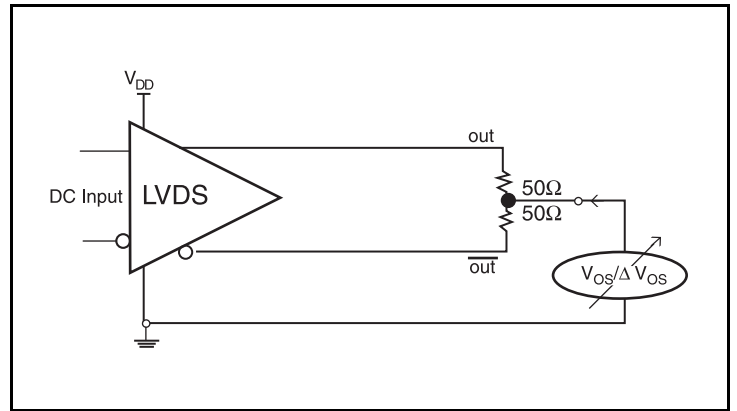

Offset Voltage Setup

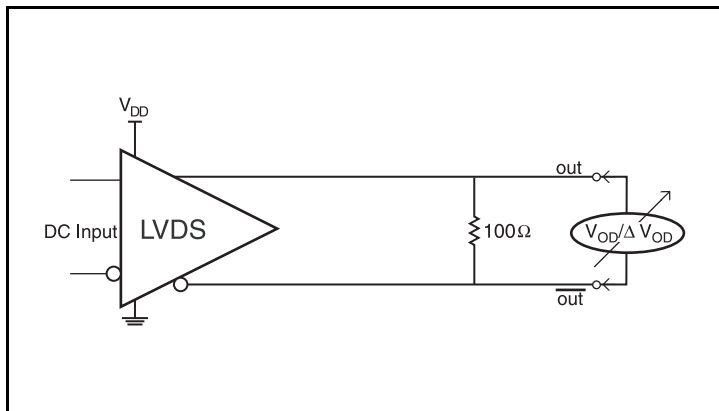

Differential Output Voltage Setup

Applications Information

Recommendations for Unused Input and Output Pins

Inputs:

PCLK/nPCLK Inputs

For applications not requiring the use of a differential input, both the PCLK and nPCLK pins can be left floating. Though not required, but for additional protection, a 1kΩ resistor can be tied from PCLK to ground.

Outputs:

LVDS Outputs

All unused LVDS output pairs can be either left floating or terminated with 100Ω across. If they are left floating, there should be no trace attached.

Wiring the Differential Input to Accept Single-Ended Levels

Figure 1 shows how a differential input can be wired to accept single ended levels. The reference voltage $V1 = V_{DD}/2$ is generated by the bias resistors R1 and R2. The bypass capacitor (C1) is used to help filter noise on the DC bias. This bias circuit should be located as close to the input pin as possible. The ratio of R1 and R2 might need to be adjusted to position the V1 in the center of the input voltage swing. For example, if the input clock swing is 2.5V and $V_{DD} = 2.5V$, R1 and R2 value should be adjusted to set V1 at 1.25V. The values below are for when both the single ended swing and V_{DD} are at the same voltage. This configuration requires that the sum of the output impedance of the driver (R_o) and the series resistance (R_s) equals the transmission line impedance. In addition, matched termination at the input will attenuate the signal in half. This can be done in one of two ways. First, R3 and R4 in parallel should equal the transmission line impedance. For most 50Ω applications, R3 and R4 can be 100Ω.

The values of the resistors can be increased to reduce the loading for slower and weaker LVCMOS driver. When using single-ended signaling, the noise rejection benefits of differential signaling are reduced. Even though the differential input can handle full rail LVCMOS signaling, it is recommended that the amplitude be reduced. The datasheet specifies a lower differential amplitude, however this only applies to differential signals. For single-ended applications, the swing can be larger, however V_{IL} cannot be less than -0.3V and V_{IH} cannot be more than $V_{DD} + 0.3V$. Suggest edge rate faster than 1V/ns. Though some of the recommended components might not be used, the pads should be placed in the layout. They can be utilized for debugging purposes. The datasheet specifications are characterized and guaranteed by using a differential signal.

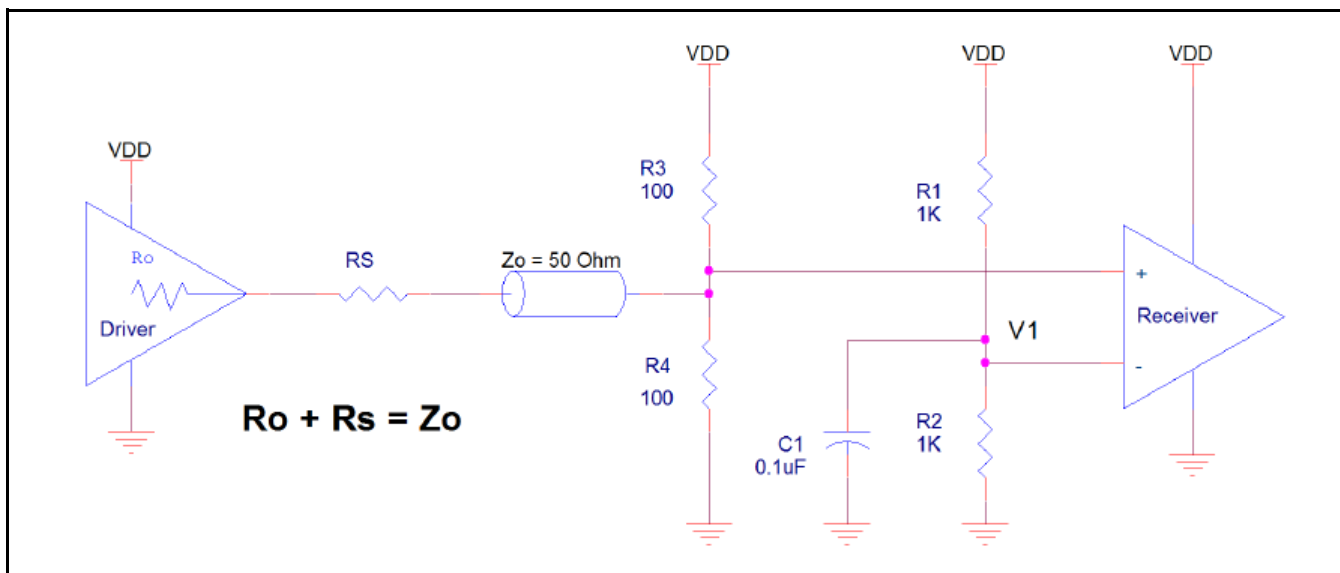

Figure 1. Recommended Schematic for Wiring a Differential Input to Accept Single-ended Levels

2.5V LVPECL Clock Input Interface

The PCLK /nPCLK accepts LVPECL, LVDS, and other differential signals. Both signals must meet the V_{PP} and V_{CMR} input requirements. *Figures 2A to 2C* show interface examples for the PCLK/ nPCLK input driven by the most common driver types. The

input interfaces suggested here are examples only. If the driver is from another vendor, use their termination recommendation. Please consult with the vendor of the driver component to confirm the driver termination requirements.

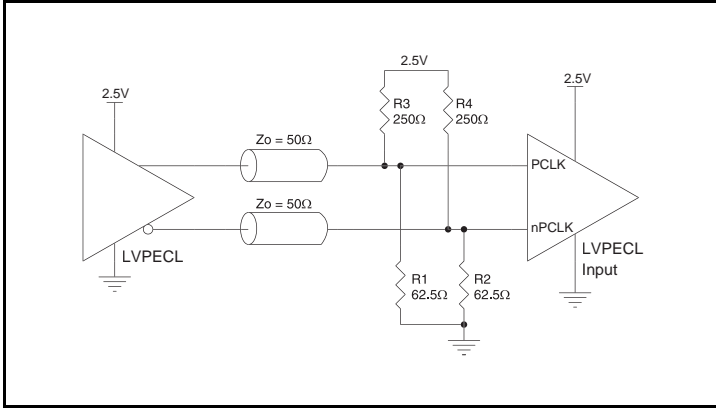

Figure 2A. PCLK/nPCLK Input Driven by a 2.5V LVPECL Driver

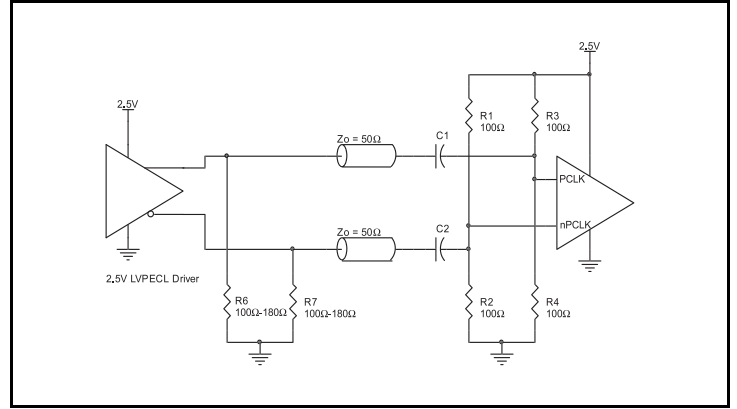

Figure 2B. PCLK/nPCLK Input Driven by a 2.5V LVPECL Driver with AC Couple

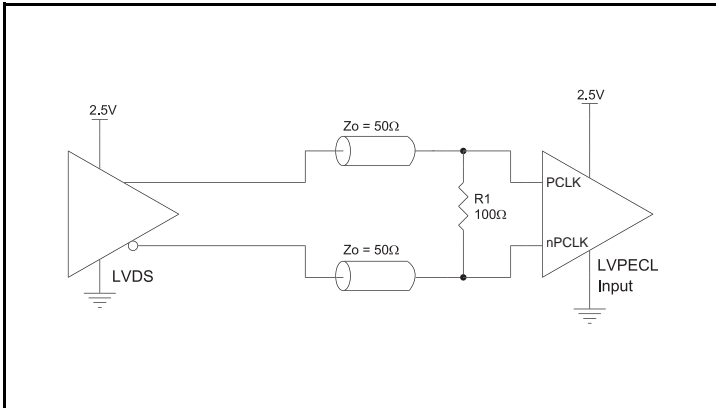
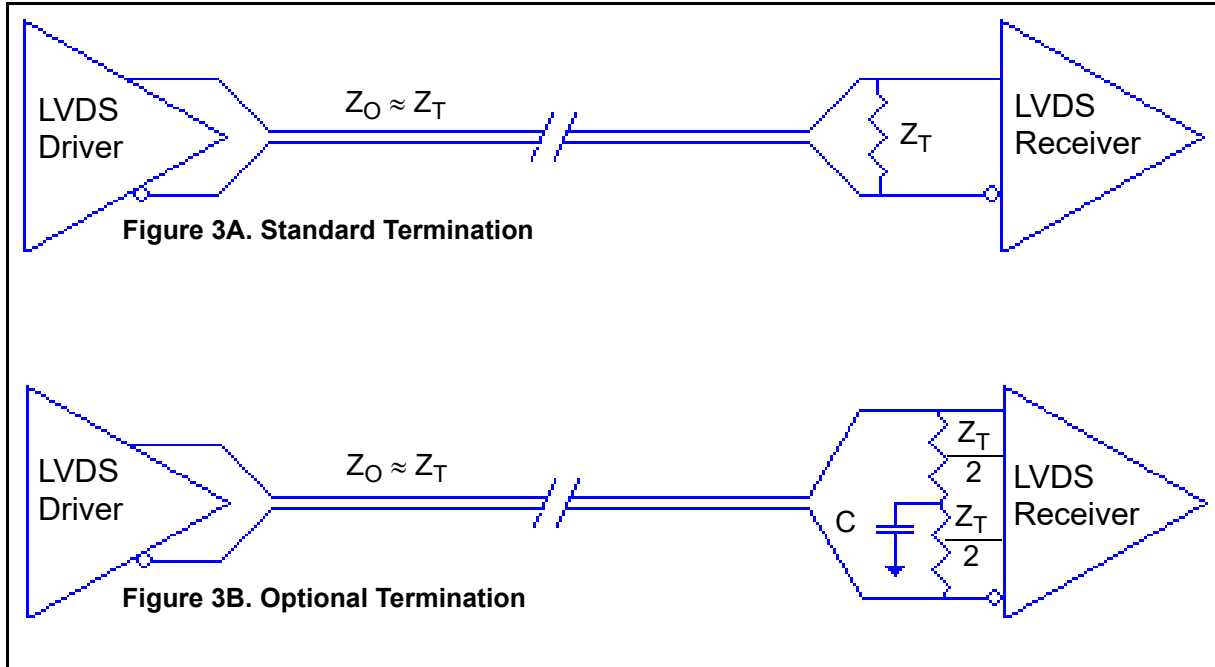

Figure 2C. PCLK/nPCLK Input Driven by a 2.5V LVDS Driver

LVDS Driver Termination

For a general LVDS interface, the recommended value for the termination impedance (Z_T) is between 90Ω and 132Ω . The actual value should be selected to match the differential impedance (Z_0) of your transmission line. A typical point-to-point LVDS design uses a 100Ω parallel resistor at the receiver and a 100Ω differential transmission-line environment. In order to avoid any transmission-line reflection issues, the components should be surface mounted and must be placed as close to the receiver as possible. IDT offers a full line of LVDS compliant devices with two types of output structures: current source and voltage source. The

standard termination schematic as shown in *Figure 3A* can be used with either type of output structure. *Figure 3B*, which can also be used with both output types, is an optional termination with center tap capacitance to help filter common mode noise. The capacitor value should be approximately 50pF . If using a non-standard termination, it is recommended to contact IDT and confirm if the output structure is current source or voltage source type. In addition, since these outputs are LVDS compatible, the input receiver's amplitude and common-mode input range should be verified for compatibility with the output.



LVDS Termination

VFQFPN EPAD Thermal Release Path

In order to maximize both the removal of heat from the package and the electrical performance, a land pattern must be incorporated on the Printed Circuit Board (PCB) within the footprint of the package corresponding to the exposed metal pad or exposed heat slug on the package, as shown in *Figure 4*. The solderable area on the PCB, as defined by the solder mask, should be at least the same size/shape as the exposed pad/slug area on the package to maximize the thermal/electrical performance. Sufficient clearance should be designed on the PCB between the outer edges of the land pattern and the inner edges of pad pattern for the leads to avoid any shorts.

While the land pattern on the PCB provides a means of heat transfer and electrical grounding from the package to the board through a solder joint, thermal vias are necessary to effectively conduct from the surface of the PCB to the ground plane(s). The land pattern must be connected to ground through these vias. The vias act as “heat pipes”. The number of vias (i.e. “heat pipes”) are application specific

and dependent upon the package power dissipation as well as electrical conductivity requirements. Thus, thermal and electrical analysis and/or testing are recommended to determine the minimum number needed. Maximum thermal and electrical performance is achieved when an array of vias is incorporated in the land pattern. It is recommended to use as many vias connected to ground as possible. It is also recommended that the via diameter should be 12 to 13mils (0.30 to 0.33mm) with 1oz copper via barrel plating. This is desirable to avoid any solder wicking inside the via during the soldering process which may result in voids in solder between the exposed pad/slug and the thermal land. Precautions should be taken to eliminate any solder voids between the exposed heat slug and the land pattern. Note: These recommendations are to be used as a guideline only. For further information, please refer to the Application Note on the Surface Mount Assembly of Amkor’s Thermally/Electrically Enhance Leadframe Base Package, Amkor Technology.

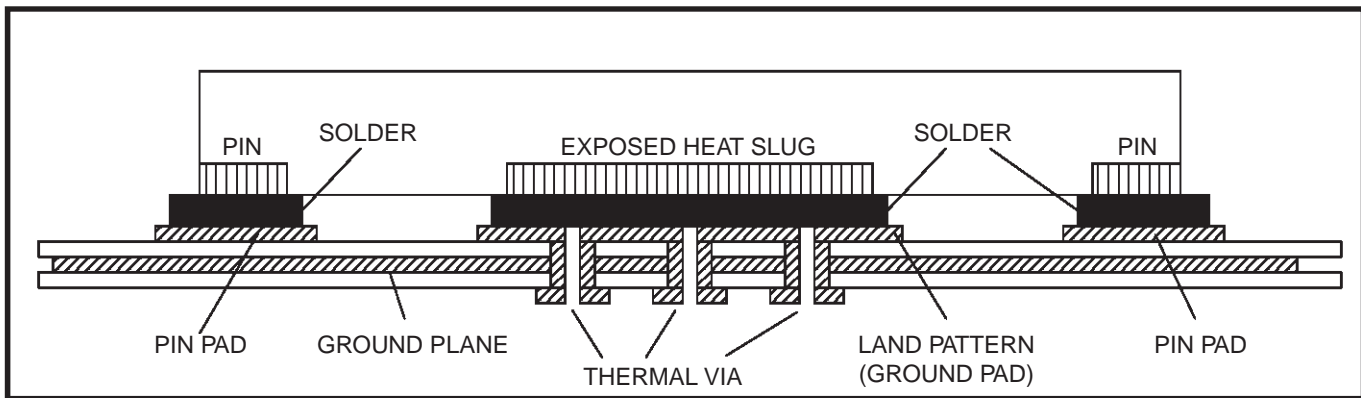

Figure 4. P.C. Assembly for Exposed Pad Thermal Release Path – Side View (drawing not to scale)

Power Considerations

This section provides information on power dissipation and junction temperature for the 8SLVD2102. Equations and example calculations are also provided.

1. Power Dissipation.

The total power dissipation for the 8SLVD2102 is the sum of the core power plus the output power dissipation due to the load. The following is the power dissipation for $V_{DD} = 2.5V + 5\% = 2.625V$, which gives worst case results.

The maximum current at 85°C is as follows: $I_{DD_MAX} = 84mA$

- $Power_{(core)MAX} = V_{DD_MAX} * I_{DD_MAX} = 2.625V * 84mA = \mathbf{220.5mW}$

Total Power_MAX = 220.5mW

2. Junction Temperature.

Junction temperature, T_j , is the temperature at the junction of the bond wire and bond pad directly affects the reliability of the device. The maximum recommended junction temperature is 125°C. Limiting the internal transistor junction temperature, T_j , to 125°C ensures that the bond wire and bond pad temperature remains below 125°C.

The equation for T_j is as follows: $T_j = \theta_{JA} * Pd_total + T_A$

T_j = Junction Temperature

θ_{JA} = Junction-to-Ambient Thermal Resistance

Pd_total = Total Device Power Dissipation (example calculation is in section 1 above)

T_A = Ambient Temperature

In order to calculate junction temperature, the appropriate junction-to-ambient thermal resistance θ_{JA} must be used. Assuming no air flow and a multi-layer board, the appropriate value is 74.7°C/W per Table 6 below.

Therefore, T_j for an ambient temperature of 85°C with all outputs switching is:

$$85^\circ C + 0.221W * 74.7^\circ C/W = 101.5^\circ C. \text{ This is below the limit of } 125^\circ C.$$

This calculation is only an example. T_j will obviously vary depending on the number of loaded outputs, supply voltage, air flow and the type of board (multi-layer).

Table 6. Thermal Resistance θ_{JA} for 16 Lead VFQFPN, Forced Convection

| θ_{JA} at 0 Air Flow | | | |
|---|----------|----------|----------|
| Meters per Second | 0 | 1 | 2.5 |
| Multi-Layer PCB, JEDEC Standard Test Boards | 74.7°C/W | 65.3°C/W | 58.5°C/W |

Reliability Information

Table 7. θ_{JA} vs. Air Flow Table for a 16 Lead VFQFPN

| θ_{JA} at 0 Air Flow | | | |
|---|----------|----------|----------|
| Meters per Second | 0 | 1 | 2.5 |
| Multi-Layer PCB, JEDEC Standard Test Boards | 74.7°C/W | 65.3°C/W | 58.5°C/W |

Transistor Count

The transistor count for the 8SLVD2102 is: 993

Package Outline Drawings

The package outline drawings are located at the end of this document. The package information is the most current data available and is subject to change without notice or revision of this document.

Ordering Information

Table 8. Ordering Information

| Part/Order Number | Marking | Package | Shipping Packaging | Temperature |
|-------------------|---------|---------------------------|---|---------------|
| 8SLVD2102NLGI | 2102I | 16 Lead VFQFPN, Lead-Free | Tube | -40°C to 85°C |
| 8SLVD2102NLGI8 | 2102I | 16 Lead VFQFPN, Lead-Free | Tape & Reel pin 1 orientation: EIA-481-C | -40°C to 85°C |
| 8SLVD2102NLGI/W | 2102I | 16 Lead VFQFPN, Lead-Free | Tape & Reel pin 1 orientation: EIA-481-D | -40°C to 85°C |

Table 9. Pin 1 Orientation in Tape and Reel Packaging

| Part Number Suffix | Pin 1 Orientation | Illustration |
|--------------------|------------------------|--------------|
| 8 | Quadrant 1 (EIA-481-C) | |
| /W | Quadrant 2 (EIA-481-D) | |

Revision History

| Revision Date | Description of Change |
|-------------------|---|
| January 21, 2018 | <ul style="list-style-type: none"> Updated the package outline drawings; however, no technical changes. Replaced the package term VFQFN with VFQFPN. |
| November 11, 2015 | <p>Section , "Pin Assignment" - updated Pin Assignment format.</p> <p>Section , "Parameter Measurement Information, continued" - changed MUX Isolation to Channel Isolation.</p> <p>Throughout the datasheet, deleted "IDT" prefix and "I" suffix from the part number.</p> |



Corporate Headquarters
 6024 Silver Creek Valley Road
 San Jose, CA 95138 USA
www.IDT.com

Sales
 1-800-345-7015 or 408-284-8200
 Fax: 408-284-2775
www.IDT.com/go/sales

Tech Support
www.idt.com/go/support

DISCLAIMER Integrated Device Technology, Inc. (IDT) and its affiliated companies (herein referred to as "IDT") reserve the right to modify the products and/or specifications described herein at any time, without notice, at IDT's sole discretion. Performance specifications and operating parameters of the described products are determined in an independent state and are not guaranteed to perform the same way when installed in customer products. The information contained herein is provided without representation or warranty of any kind, whether express or implied, including, but not limited to, the suitability of IDT's products for any particular purpose, an implied warranty of merchantability, or non-infringement of the intellectual property rights of others. This document is presented only as a guide and does not convey any license under intellectual property rights of IDT or any third parties.

IDT's products are not intended for use in applications involving extreme environmental conditions or in life support systems or similar devices where the failure or malfunction of an IDT product can be reasonably expected to significantly affect the health or safety of users. Anyone using an IDT product in such a manner does so at their own risk, absent an express, written agreement by IDT.

Integrated Device Technology, IDT and the IDT logo are trademarks or registered trademarks of IDT and its subsidiaries in the United States and other countries. Other trademarks used herein are the property of IDT or their respective third party owners. For datasheet type definitions and a glossary of common terms, visit www.idt.com/go/glossary. Integrated Device Technology, Inc All rights reserved.

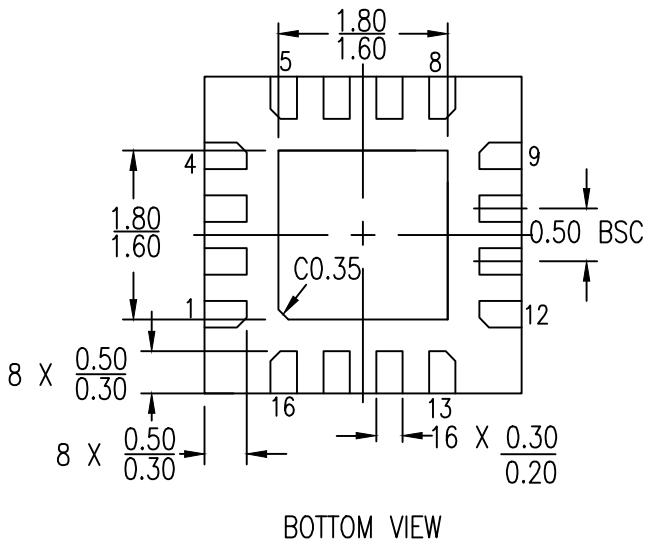
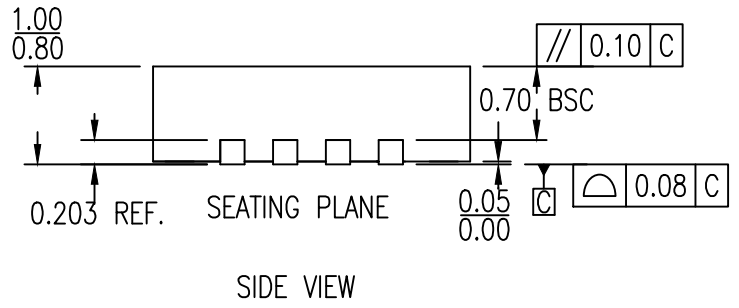
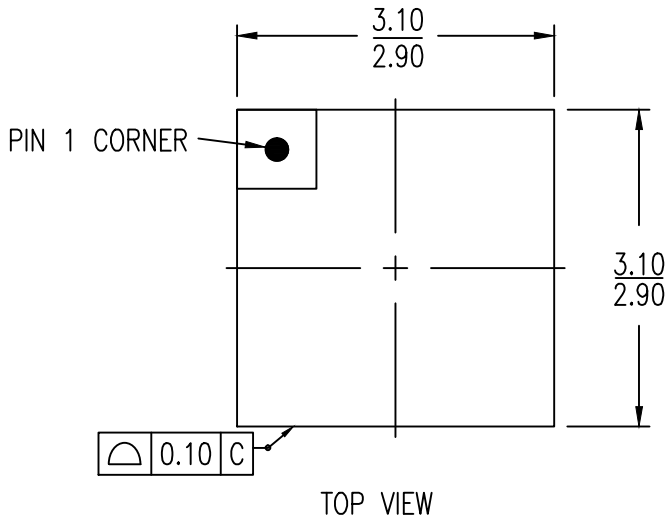

NOTES:
 1. ALL DIMENSIONS ARE IN mm. ANGLES IN DEGREES

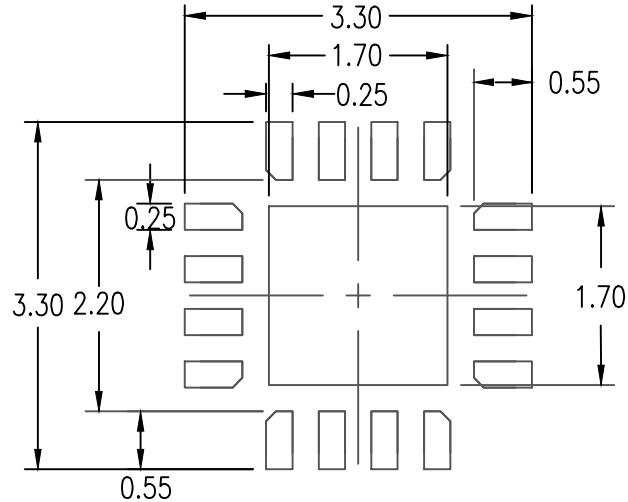

RECOMMENDED LAND PATTERN DIMENSION

NOTES:

1. ALL DIMENSIONS ARE IN mm. ANGLES IN DEGREES
2. TOP DOWN VIEW-AS VIEWED ON PCB
3. LAND PATTERN RECOMMENDATION IS PER IPC-7351B GENERIC REQUIREMENT FOR SURFACE MOUNT DESIGN AND LAND PATTERN

| Package Revision History | | |
|--------------------------|---------|---|
| Date Created | Rev No. | Description |
| Oct 25, 2017 | Rev 04 | Remove Bookmak at Pdf Format & Update Thickness Tolerance |
| Jan 18, 2018 | Rev 05 | Change QFN to VFQFPN |

Компания «Life Electronics» занимается поставками электронных компонентов импортного и отечественного производства от производителей и со складов крупных дистрибьюторов Европы, Америки и Азии.

С конца 2013 года компания активно расширяет линейку поставок компонентов по направлению коаксиальный кабель, кварцевые генераторы и конденсаторы (керамические, пленочные, электролитические), за счёт заключения дистрибьюторских договоров

Мы предлагаем:

- Конкурентоспособные цены и скидки постоянным клиентам.
- Специальные условия для постоянных клиентов.
- Подбор аналогов.
- Поставку компонентов в любых объемах, удовлетворяющих вашим потребностям.
- Приемлемые сроки поставки, возможна ускоренная поставка.
- Доставку товара в любую точку России и стран СНГ.
- Комплексную поставку.
- Работу по проектам и поставку образцов.
- Формирование склада под заказчика.
- Сертификаты соответствия на поставляемую продукцию (по желанию клиента).
- Тестирование поставляемой продукции.
- Поставку компонентов, требующих военную и космическую приемку.
- Входной контроль качества.
- Наличие сертификата ISO.

В составе нашей компании организован Конструкторский отдел, призванный помогать разработчикам, и инженерам.

Конструкторский отдел помогает осуществить:

- Регистрацию проекта у производителя компонентов.
- Техническую поддержку проекта.
- Защиту от снятия компонента с производства.
- Оценку стоимости проекта по компонентам.
- Изготовление тестовой платы монтаж и пусконаладочные работы.



Тел: +7 (812) 336 43 04 (многоканальный)

Email: org@lifeelectronics.ru