

AEDx-8xxx-xxx

2- or 3-Channel Incremental Encoder Kit with Codewheel



Data Sheet



Description

The AEDx-8xxx comes in an option of two-channel or three-channel optical incremental encoder kit with code-wheel integrated in a protective housing. The encoder is lead free and compliant to the RoHS directive. Each encoder kit consists of a collimated LED source and a detector IC enclosed within a small plastic package.

The AEDx-8xxx optical encoder has two-channel quadrature outputs (A,B) plus a third channel index output (I). There are three index options available. i.e. ungated, gated-90° and gated-180° electrical degree index pulse.

The AEDx-8xxx series optical encoder is designed for use with motors with shaft diameters of 2mm and up to 5mm. The quadrature, index and power supplied to the encoder are accessed through an 8-pin male connector of 1.25 mm pitch.

The AEDx-8xxx solution enables the servo system to be more compact. With the aid of alignment jig, the assembly process will also require less alignment time, thus making the assembly process much easier for servo motor integration.

Applications

The AEDx-8xxx provides motion detection for DC servo motor and closed loop stepper motor feedback system in the following applications:

- Pick and Place machines
- Semiconductor equipment
- Factory automation equipment

Features

- 3-channel differential output (A,B) with ungated, gated-90° and gated-180° index pulse (I)
- 2-channel differential output available
- Up to 500 Cycles Per Revolution (CPR)
- Up to 30000 rpm motor speed
- -40 °C to 100 °C operating temperature
- Single 5 V supply
- Integrated RS-422 line driver
- Quick and easy assembly

Assembly View

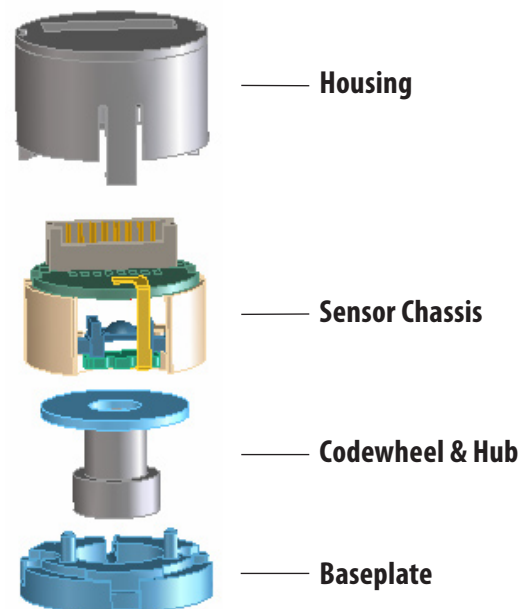

Note: Avago Technologies encoders are not recommended for use in safety critical applications, e.g., ABS braking systems, power steering, life support systems and critical care medical equipment. Avago's products and software are not specifically designed, manufactured or authorized for sale as parts, components or assemblies for the planning, construction, maintenance or direct operation of a nuclear facility or for use in medical devices or applications. Customers are solely responsible, and waive all rights to make claims against Avago or its suppliers, for all losses, damage, expense or liability in connection with such use. Please contact your local sales representative if more clarification is needed.

Theory of Operation

The AEDx-8xxx optical encoder is a housed solution with integrated encoder and codewheel. The encoder translates the rotary motion of a shaft into incremental digital outputs.

The encoder contains a single Light Emitting Diode (LED) as the light source. The light is collimated into a parallel beam by means of polycarbonate lens located directly over the LED. Opposite the emitter is a detector IC. This IC consists of multiple sets of photo detectors and signal processing circuitry necessary to produce the digital waveform output. The codewheel rotates between the emitter and detector, causing the light beam to be interrupted by pattern of spaces and bars on the codewheel. The Photodiodes that detect these interruptions are arranged in a pattern that corresponds to the radius and design of the codewheel. These detectors are also spaced in such way that light period on one pair of detectors corresponds to dark period on adjacent pair of detectors. The photodiode outputs are then fed through the signal processing circuitry that produce the final outputs for channel A and B. Due to this integrated phasing technique, the digital output of channel A is in quadrature with that of channel B (90 electrical degrees out of phase). As a standard, the outputs are fed through a standard RS422 line driver to deliver the differentials signals at the final encoder output.

Definitions

Cycles (N): The number of electrical cycles per revolution (CPR).

Note: CPR refers to the raw signal from encoder, that is the cycles before 4x decode.

One Cycle: 360 electrical degrees ($^{\circ}e$).

One Shaft Rotation: 360 mechanical degrees.

Cycle Error (ΔC): An indication of cycle uniformity. The difference between an observed shaft angle which gives rise to one electrical cycle, and the nominal angular increment of $1/N$ of a revolution.

Pulse Width (P): The number of electrical degrees that an output is high during 1 cycle. This value is nominally $180^{\circ}e$ or $1/2$ cycle.

Pulse Width Error (ΔP): The deviation, in electrical degrees, of the pulse width from its ideal value of $180^{\circ}e$.

State Width (S): The numbers of electrical degrees between transitions in the output of channel A and the neighboring transition in the output of channel B. There are 4 states per cycle, each nominally $90^{\circ}e$.

State Width Error (ΔS): The deviation, in electrical degrees, of each state width from its ideal value of $90^{\circ}e$.

Phase (Φ): The numbers of electrical degrees between the center of the high state of channel A and the center of the high state of channel B. This value is nominally $90^{\circ}e$ for quadrature output.

Phase Error ($\Delta\Phi$): The deviation of the phase from its ideal value of $90^{\circ}e$.

Index Pulse Width (P_o): The number of electrical degrees that an index is high with reference to channel A or channel B during one full shaft rotation.

Absolute Maximum Ratings ^[1,2]

Parameter	Symbol	Min.	Max.	Units
1. Storage Temperature AEDS Series	T_S	-20	85	$^{\circ}C$
Storage Temperature AEDT Series	T_S	-40	100	$^{\circ}C$
2. Supply Voltage	V_{CC}	-0.5	7	V
3. Output Voltage	V_{out}	-0.5	V_{CC}	V
4. Output Current per Channel	I_{out}	-	± 150	mA
5. Shaft Axial Play		-	± 0.100	mm
6. Shaft Radial Play Plus Eccentricity		-	± 0.080	mm

Note:

1. Absolute Maximum Ratings are those values beyond which the safety of the device cannot be guaranteed. They are not meant to imply that the device should be operated at these limits.
2. Stresses greater than those listed under Absolute Maximum Ratings may cause permanent damage to the device. Exposure to absolute maximum rating conditions for extended periods may affect reliability.

Recommended Operating Conditions

Parameter	Symbol	Min.	Typ.	Max.	Units	Notes
1. Operating Temperature AEDS Series	T_A	-20	-	85	°C	
Operating Temperature AEDT Series	T_A	-40	-	100	°C	
2. Supply Voltage	V_{CC}	4.5	5.0	5.5	V	
3. Output frequency (200 CPR)	f	-	-	100	kHz	Velocity(rpm) x N/60
4. Output frequency (400 & 500 CPR)		-	-	200		

Encoding Characteristics ($V_{CC} = 4.5$ to $5.5V$, $T_{amb} = -40$ to $+100^{\circ}C$)

AEDx-8xxx-Exx (200 CPR only)

Parameter	Symbol	Min.	Typ.(3)	Max	Units	Notes
1. Pulse Width Error	ΔP	-	5	35	°e	
2. State Width Error	ΔS	-	3	35	°e	
3. Phase Error	$\Delta \phi$	-	2	20	°e	
4. Cycle Error	ΔC	-	5	15	°e	
5. Index Pulse Width Un-gated	P_o	220	360	500	°e	
Index Pulse Width Gated 90°e	P_o	60	90	120	°e	
Index Pulse Width Gated 180°e	P_o	140	180	220	°e	
6. Position Error	$\Delta \theta$	-	15	50	min. of arc	

Note 3: Typical values specified at $V_{CC} = 5.0V$ and $25^{\circ}C$

Encoding Characteristics ($V_{CC} = 4.5$ to $5.5V$, $T_{amb} = -40$ to $+100^{\circ}C$)

AEDx-8xxx-xxx (400 & 500CPR)

Parameter	Symbol	Min.	Typ.(3)	Max	Units	Notes
1. Pulse Width Error	ΔP	-	7	60	°e	
2. State Width Error	ΔS	-	5	60	°e	
3. Phase Error	$\Delta \phi$	-	2	35	°e	
4. Cycle Error	ΔC	-	7	30	°e	
5. Index Pulse Width Un-gated	P_o	220	360	500	°e	
Index Pulse Width Gated 90°e	P_o	50	90	130	°e	
Index Pulse Width Gated 180°e	P_o	135	180	225	°e	
6. Position Error	$\Delta \theta$	-	20	60	min. of arc	

Note 3: Typical values specified at $V_{CC} = 5.0V$ and $25^{\circ}C$

Electrical Characteristics ($V_{CC} = 4.5$ to $5.5V$, $T_{amb} = -40$ to $+100^{\circ}C$)

Parameter	Symbol	Min.	Typ.[1]	Max	Units	Notes
1. Supply Current	I_{CC}	-	42	50	mA	
2. Output High Level	V_{OH}	2.5	3.4	-	V	$I_o = -20mA$
3. Output Low Level	V_{OL}	-	0.3	0.5	V	$I_o = 20mA$
4. Output Current	I_o	-	25	40	mA	
5. Rise time	t_r	-	30	100	ns	
6. Fall time	t_f	-	30	100	ns	

Note:

1. Typical values specified at $V_{CC} = 5.0V$ and $25^{\circ}C$.

Pin Assignments

Pin	Signal	Description
Pin 1	GND	Ground
Pin 2	A+	Digital Output
Pin 3	A-	Digital Output
Pin 4	B+	Digital Output
Pin 5	B-	Digital Output
Pin 6	I+	Digital Output
Pin 7	I-	Digital Output
Pin 8	Vcc	Voltage Input



Output Waveforms

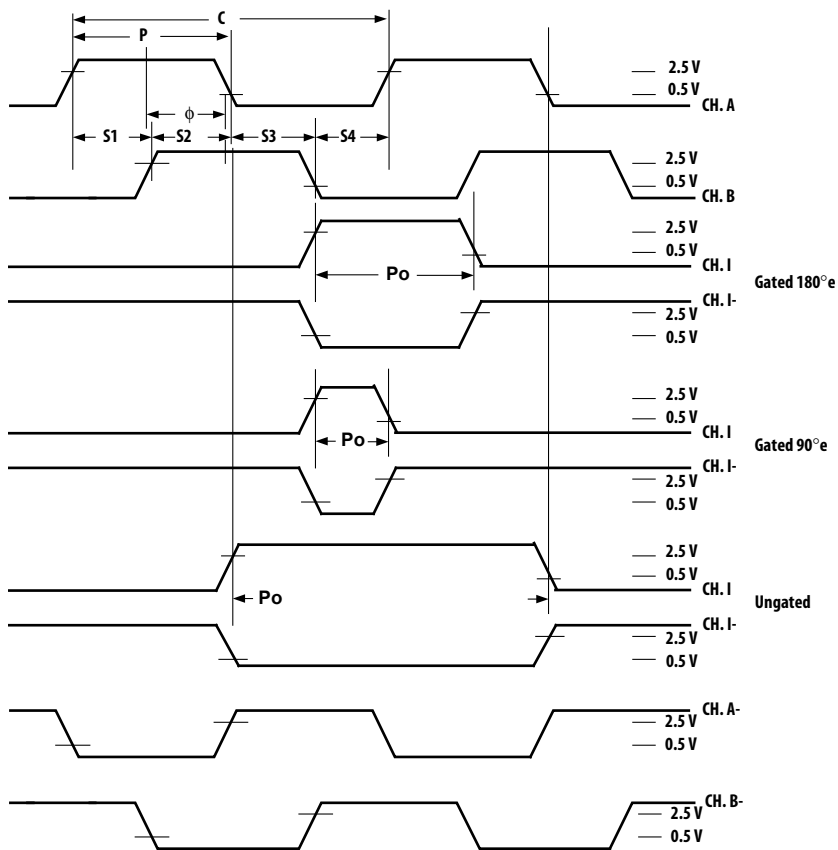
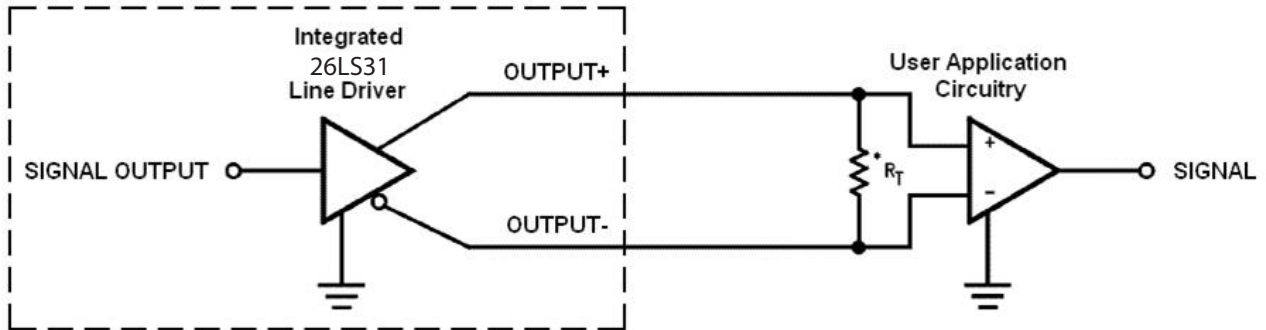

Figure 1. Output waveforms for counter-clockwise rotation, viewed from the top of the encoder.

Direction of Motor Rotation

Direction of Rotation: When the codewheel rotates in the counter-clockwise direction viewing from the top of the encoder kit, channel A will lead channel B. If the codewheel rotates in the opposite direction, channel B will lead channel A.

Electrical Interface



Note:

OUTPUT+ represents A+, B+, or I+ digital output from the encoder.

OUTPUT- represents A-, B-, or I- digital output from the encoder.

Load resistance *RT is optional although highly recommended to reduce reflection.

Package Dimensions

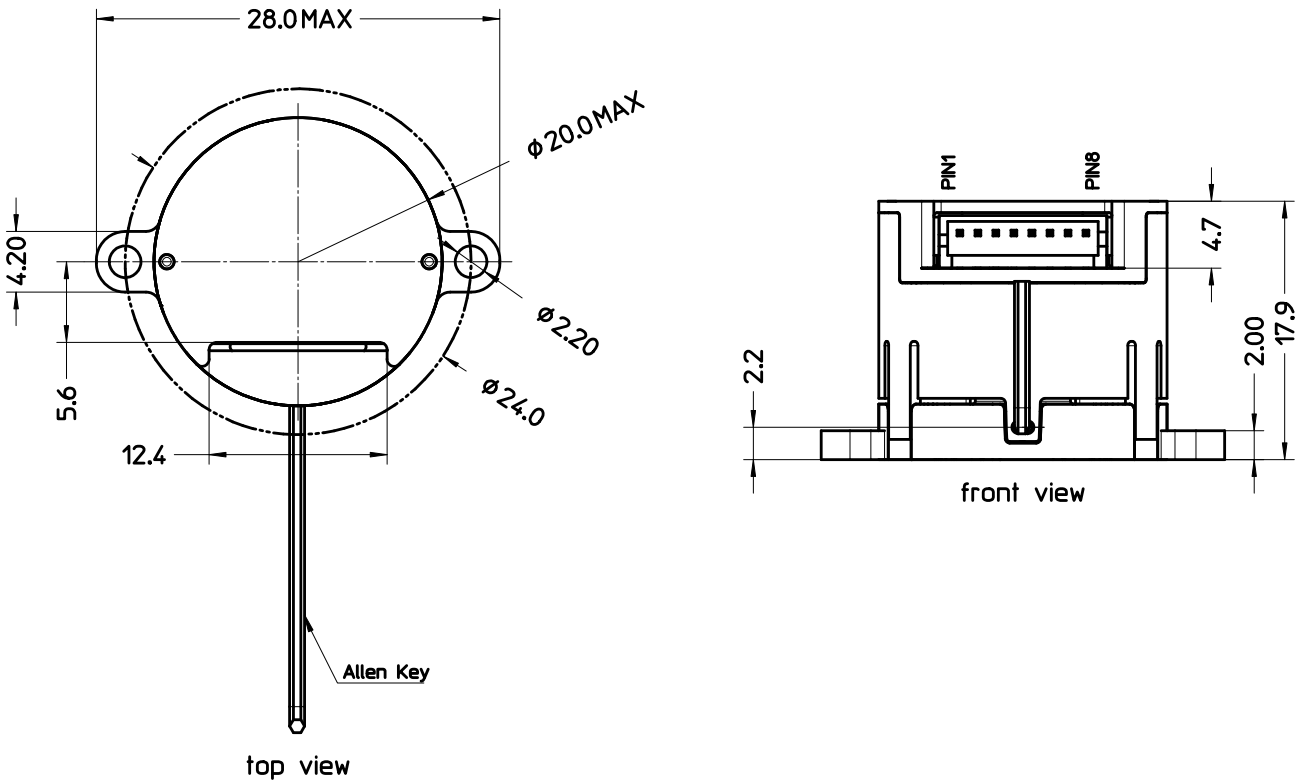

Dimensions in mm unless otherwise stated.

Tolerance: +/- 0.1mm

Figure 2. Mechanical Dimensions for Mounting Option 1 (AEDx-8x0x)

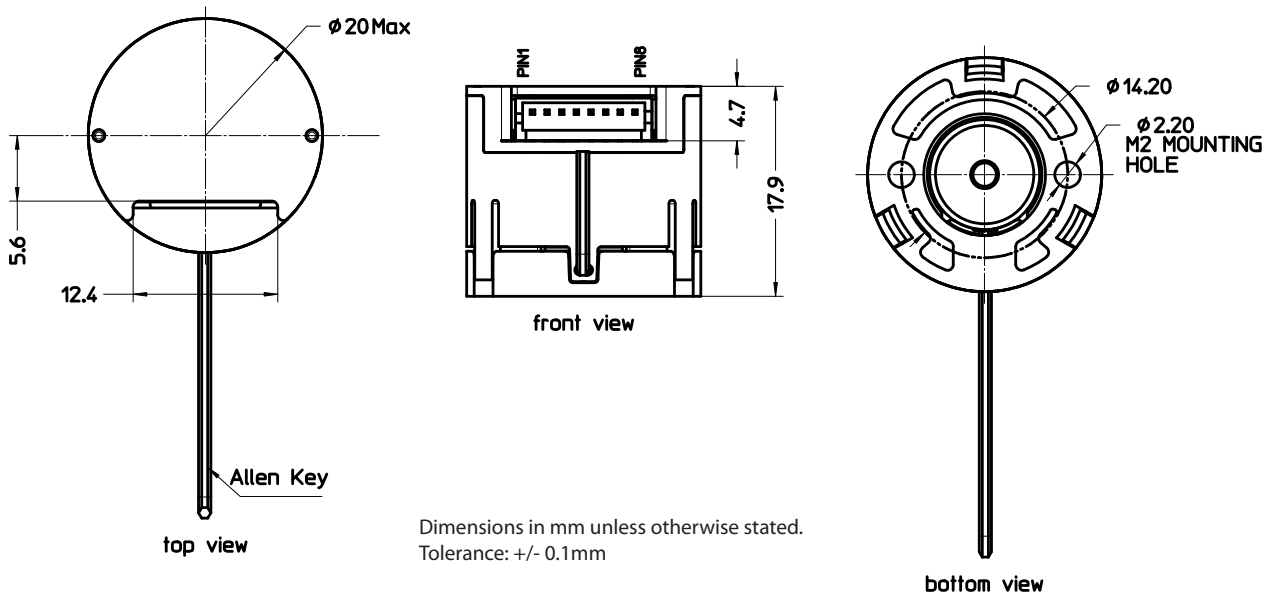
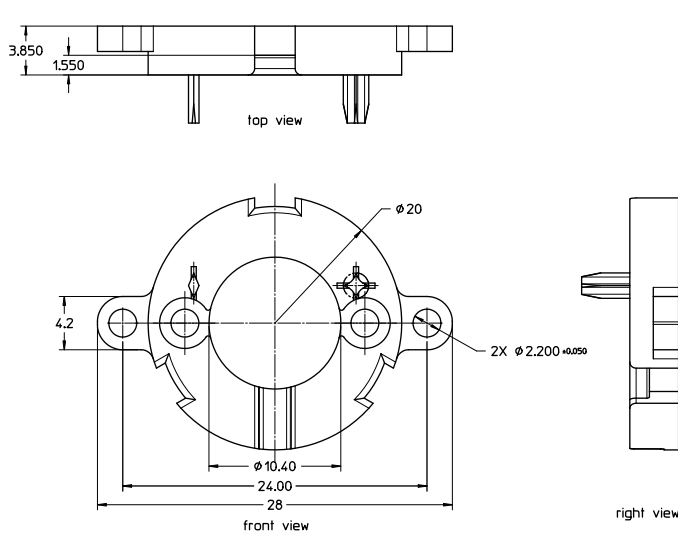

Figure 3. Mechanical Dimensions for Mounting Option 2 (AEDx-8x1x)

Mounting Considerations

Option 1 (AEDx-8x0x) with Protruded External Mounting Ear Hole



Option 2 (AEDx-8x1x) with Internal Mounting Hole

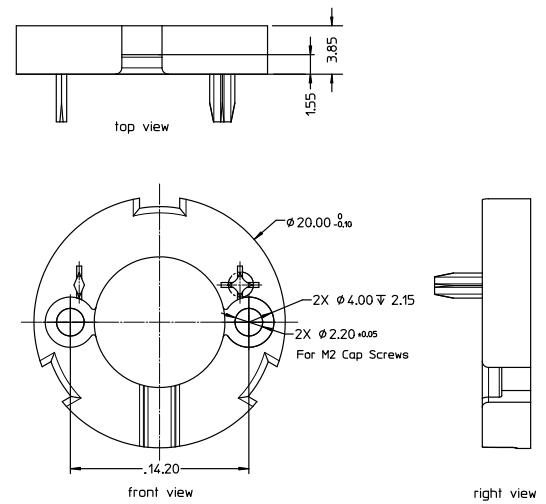

CAUTION: For optimal performance, base plate and plastic housing assembly are designed for a ONE time assembly process only. Removal and re-assembly process should be avoided due to the potential weakness of the latch after re-assembly.

Mounting Alignment Tool

Alignment Tool for AEDX-8XXX,4mm (HEDS-8938-011)

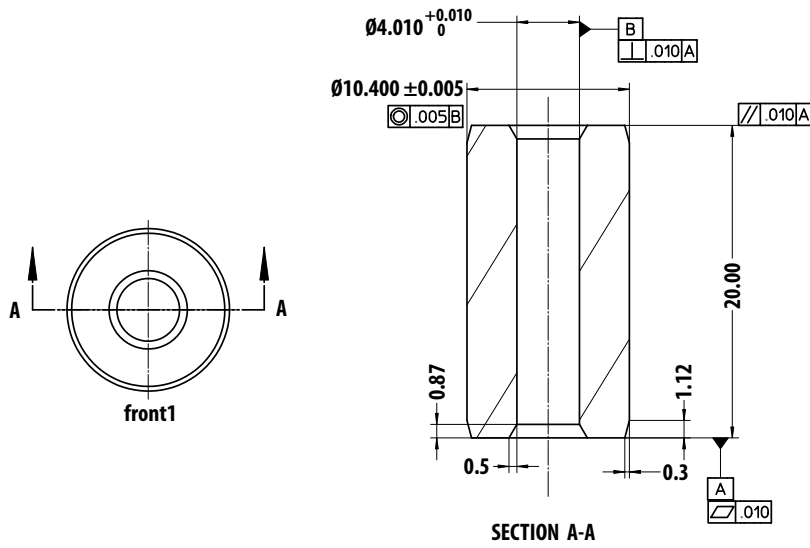

Alignment Tool for AEDX-8XXX,5mm(HEDS-8938-014)

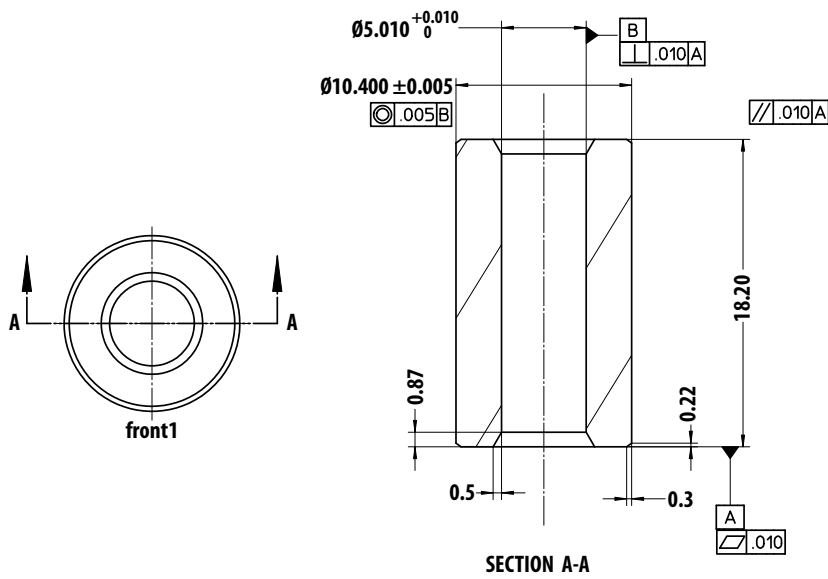

Mechanical Characteristics

Parameter	Dimension	Tolerance	Units	Notes
1. Shaft Diameter Tolerance	2, 3, 4, 5	0 -0.008	mm	
2. Recommended Shaft Length	5 to 10	N/A	mm	
3. Mounting Screw Size	2 X M2	N/A	mm	
4. Recommended Screw Torque	0.6	N/A	lb. inch	
5. Encoder Base Plate Thickness	3.85	±0.1	mm	

Recommended Mating Connectors

Temperature Option	Manufacturer	Part Number	Description
AEDS Series	Molex	53261-0871	Connector Box Type, 8-pin, 1.25mm pitch
AEDT Series	Hirose	DF13A-8P-1.25H	Connector Box Type, 8-pin, 1.25mm pitch

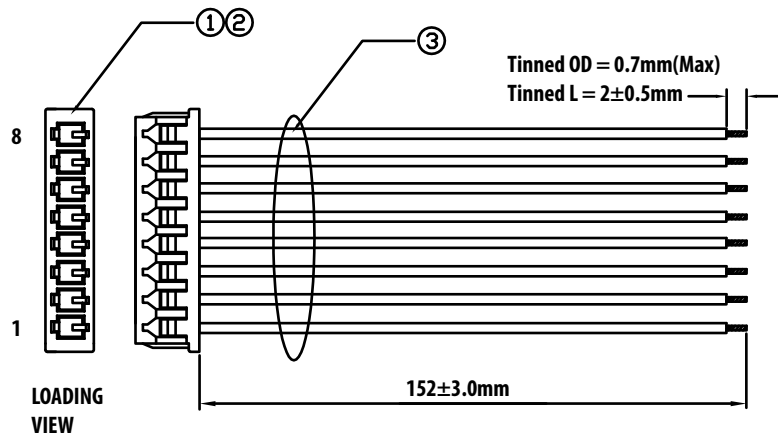

AEDS-Series (HEDS-8911-152)

Specification:

1. Housing, 8P, pitch: 1.25mm
2. Terminal, #26~28AWG
3. Wire, UL1007 #28AWG-STR
4. Blue color

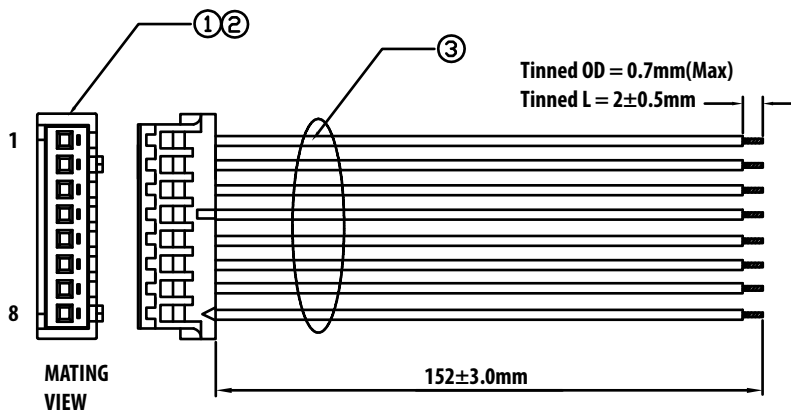

AEDT-Series (HEDT-8912-152)

Specification:

1. Housing, 8P, pitch: 1.25mm
2. Terminal, #26~30AWG
3. Wire, UL1007 #28AWG-STR
4. Grey color

Ordering Information

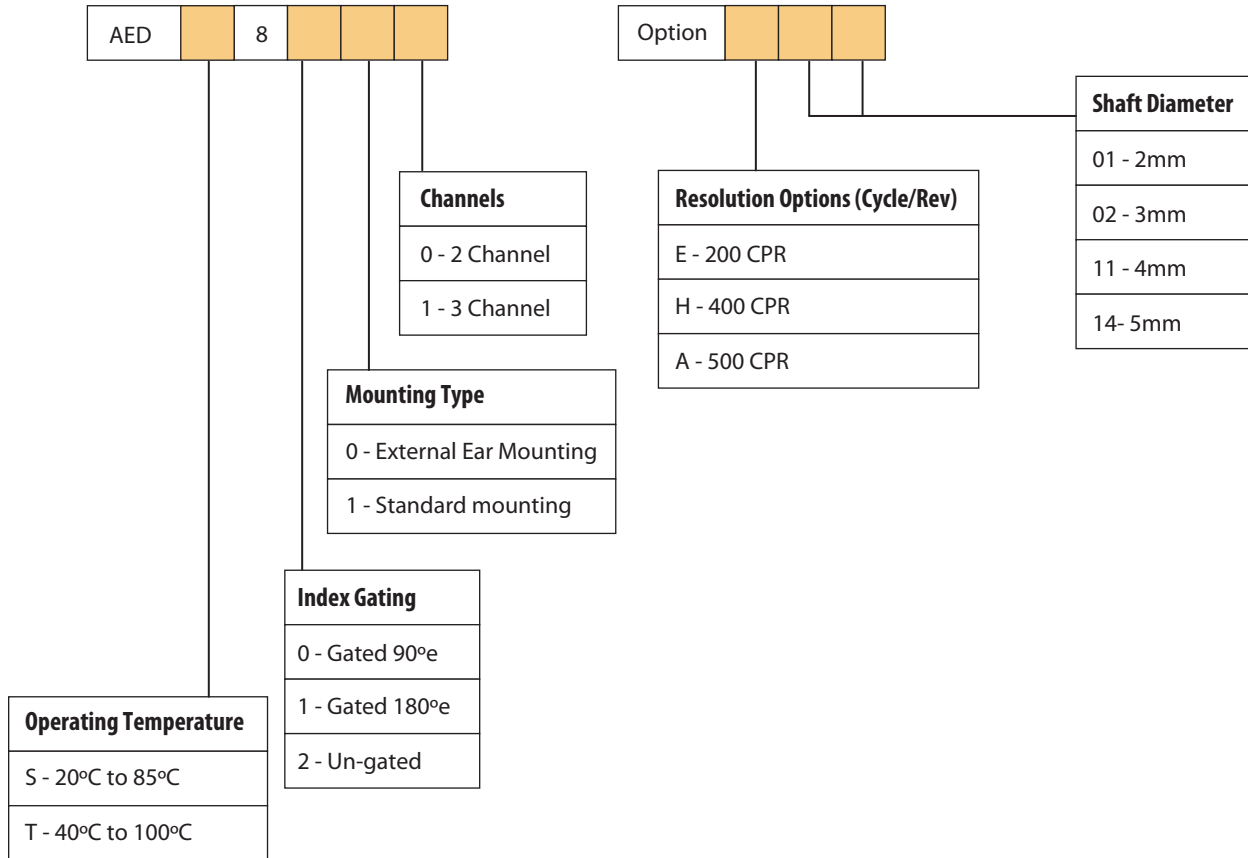

Connectors ordering information:

1. HEDS-8911-152 - Connectors for AEDS-8xxx series
2. HEDT-8912-152 - Connectors for AEDT-8xxx series

Alignment tool ordering information:

1. HEDS-8938-001 - Alignment tool for AEDx-8xxx-x01 series (2mm shaft diameter option)
2. HEDS-8938-002 - Alignment tool for AEDx-8xxx-x02 series (3mm shaft diameter option)
3. HEDS-8938-011 - Alignment tool for AEDx-8xxx-x11 series (4mm shaft diameter option)
4. HEDS-8938-014 - Alignment tool for AEDx-8xxx-x14 series (5mm shaft diameter option)

For product information and a complete list of distributors, please go to our web site: www.avagotech.com

Компания «Life Electronics» занимается поставками электронных компонентов импортного и отечественного производства от производителей и со складов крупных дистрибьюторов Европы, Америки и Азии.

С конца 2013 года компания активно расширяет линейку поставок компонентов по направлению коаксиальный кабель, кварцевые генераторы и конденсаторы (керамические, пленочные, электролитические), за счёт заключения дистрибьюторских договоров

Мы предлагаем:

- Конкуренеспособные цены и скидки постоянным клиентам.
- Специальные условия для постоянных клиентов.
- Подбор аналогов.
- Поставку компонентов в любых объемах, удовлетворяющих вашим потребностям.
- Приемлемые сроки поставки, возможна ускоренная поставка.
- Доставку товара в любую точку России и стран СНГ.
- Комплексную поставку.
- Работу по проектам и поставку образцов.
- Формирование склада под заказчика.
- Сертификаты соответствия на поставляемую продукцию (по желанию клиента).
- Тестирование поставляемой продукции.
- Поставку компонентов, требующих военную и космическую приемку.
- Входной контроль качества.
- Наличие сертификата ISO.

В составе нашей компании организован Конструкторский отдел, призванный помогать разработчикам, и инженерам.

Конструкторский отдел помогает осуществить:

- Регистрацию проекта у производителя компонентов.
- Техническую поддержку проекта.
- Защиту от снятия компонента с производства.
- Оценку стоимости проекта по компонентам.
- Изготовление тестовой платы монтаж и пусконаладочные работы.



Тел: +7 (812) 336 43 04 (многоканальный)
Email: org@lifeelectronics.ru