

BGS15AN16

SP5T Antenna Switch

Data Sheet

Revision 2.1, 2013-01-21

Edition 2013-01-21

**Published by
Infineon Technologies AG
81726 Munich, Germany**

**© 2013 Infineon Technologies AG
All Rights Reserved.**

Legal Disclaimer

The information given in this document shall in no event be regarded as a guarantee of conditions or characteristics. With respect to any examples or hints given herein, any typical values stated herein and/or any information regarding the application of the device, Infineon Technologies hereby disclaims any and all warranties and liabilities of any kind, including without limitation, warranties of non-infringement of intellectual property rights of any third party.

Information

For further information on technology, delivery terms and conditions and prices, please contact the nearest Infineon Technologies Office (www.infineon.com).

Warnings

Due to technical requirements, components may contain dangerous substances. For information on the types in question, please contact the nearest Infineon Technologies Office.

Infineon Technologies components may be used in life-support devices or systems only with the express written approval of Infineon Technologies, if a failure of such components can reasonably be expected to cause the failure of that life-support device or system or to affect the safety or effectiveness of that device or system. Life support devices or systems are intended to be implanted in the human body or to support and/or maintain and sustain and/or protect human life. If they fail, it is reasonable to assume that the health of the user or other persons may be endangered.

BGS15AN16 SP5T Antenna Switch

Revision History: 2013-01-21, Revision 2.1

Previous Revision: 2011-05-08, Revision 2.0

Page	Subjects (major changes since last revision)
8,9,10	Updated drawings

Trademarks of Infineon Technologies AG

BlueMoon™, COMNEON™, C166™, CROSSAVE™, CanPAK™, CIPOS™, CoolMOS™, CoolSET™, CORECONTROL™, DAVE™, EasyPIM™, EconoBRIDGE™, EconoDUAL™, EconoPACK™, EconoPIM™, EiceDRIVER™, EUPEC™, FCOS™, HITFET™, HybridPACK™, ISOFACE™, I²RF™, IsoPACK™, MIPAQ™, ModSTACK™, my-d™, NovalithIC™, OmniTune™, OptiMOS™, ORIGA™, PROFET™, PRO-SIL™, PRIMARION™, PrimePACK™, RASIC™, ReverSave™, SatRIC™, SensoNor™, SIEGET™, SINDRION™, SMARTi™, SmartLEWIS™, TEMPFET™, thinQ!™, TriCore™, TRENCHSTOP™, X-GOLD™, XMM™, X-PMU™, XPOSYS™.

Other Trademarks

Advance Design System™ (ADS) of Agilent Technologies, AMBA™, ARM™, MULTI-ICE™, PRIMECELL™, REALVIEW™, THUMB™ of ARM Limited, UK. AUTOSAR™ is licensed by AUTOSAR development partnership. Bluetooth™ of Bluetooth SIG Inc. CAT-iq™ of DECT Forum. COLOSSUS™, FirstGPS™ of Trimble Navigation Ltd. EMV™ of EMVCo, LLC (Visa Holdings Inc.). EPCOS™ of Epcos AG. FLEXGO™ of Microsoft Corporation. FlexRay™ is licensed by FlexRay Consortium. HYPERTERMINAL™ of Hilgraeve Incorporated. IEC™ of Commission Electrotechnique Internationale. IrDA™ of Infrared Data Association Corporation. ISO™ of INTERNATIONAL ORGANIZATION FOR STANDARDIZATION. MATLAB™ of MathWorks, Inc. MAXIM™ of Maxim Integrated Products, Inc. MICROTEC™, NUCLEUS™ of Mentor Graphics Corporation. Mifare™ of NXP. MIPI™ of MIPI Alliance, Inc. MIPS™ of MIPS Technologies, Inc., USA. muRata™ of MURATA MANUFACTURING CO., MICROWAVE OFFICE™ (MWO) of Applied Wave Research Inc., OmniVision™ of OmniVision Technologies, Inc. Openwave™ Openwave Systems Inc. RED HAT™ Red Hat, Inc. RFMD™ RF Micro Devices, Inc. SIRIUS™ of Sirius Sattelite Radio Inc. SOLARIS™ of Sun Microsystems, Inc. SPANSION™ of Spansion LLC Ltd. Symbian™ of Symbian Software Limited. TAIYO YUDEN™ of Taiyo Yuden Co. TEAKLITE™ of CEVA, Inc. TEKTRONIX™ of Tektronix Inc. TOKO™ of TOKO KABUSHIKI KAISHA TA. UNIX™ of X/Open Company Limited. VERILOG™, PALLADIUM™ of Cadence Design Systems, Inc. VLYNQ™ of Texas Instruments Incorporated. VXWORKS™, WIND RIVER™ of WIND RIVER SYSTEMS, INC. ZETEX™ of Diodes Zetex Limited.

Last Trademarks Update 2010-03-22

Table of Contents

	Table of Contents	1
	List of Figures	1
	List of Tables	1
1	Features	1
2	Signals Description	3
3	Electrical Characteristics	5
3.1	Electrical Specification	6
4	Package Outline	8

List of Figures

Figure 1	Functional Diagram.	2
Figure 2	Pin Configuration (top view)	3
Figure 3	Package Outline	8
Figure 4	Pin Marking.	8
Figure 5	Land Pattern and Stencil Mask.	9
Figure 6	Tape Drawing for PG-TSNP-16-6.	9

List of Tables

Table 1	Pin Description (top view).....	3
Table 2	Truth Table.....	4
Table 3	Absolute Maximum Ratings.....	5
Table 4	Operating Ranges.....	5
Table 5	ESD Ratings.....	5
Table 6	Electrical Characteristics.....	6
Table 7	Electrical Characteristics (cont'd).....	7

1 Features

Main Features

- 5 high-linearity Rx ports with power handling capability of up to 30 dBm
- All ports fully symmetrical
- No external decoupling components required
- High ESD robustness
- Low harmonic generation
- Low insertion loss
- High port-to-port-isolation
- 0.1 to 3.0 GHz coverage
- Direct connection to battery
- Power down mode
- On-chip control logic supporting logic levels from 1.5 V to Vdd
- Lead and halogen free package (RoHS and WEEE compliant)
- Small leadless package TSNP16 with the size of 2.3 x 2.3 mm² and a maximum height of 0.73 mm.



Applications

- WCDMA diversity
- CDMA diversity
- Analog and Digital Tuner
- Band Switching
- LTE

Description

The BGS15AN16 RF MOS switch is specifically designed for WCDMA diversity applications. Any of the 5 ports can be used as termination of the diversity antenna handling up to 30 dBm.

This SP5T offers low insertion loss and high robustness against interferer signals at the antenna port and low harmonic generation in termination mode.

An integrated LDO allows to connect V_{dd} directly to battery, hence no regulated supply voltage is required. A power down mode is implemented to avoid current drain when the device is not in use.

The on-chip controller integrates CMOS logic and level shifters, driven by control inputs from 1.5 V to Vdd. Unlike GaAs technology, external DC blocking capacitors at the RF Ports are only required if DC voltage is applied externally.

The BGS15AN16 RF Switch is manufactured in Infineon's patented MOS technology, offering the performance of GaAs with the economy and integration of conventional CMOS including the inherent higher ESD robustness.

The device has a very small size of only 2.3 x 2.3 mm² and a maximum height of 0.73 mm

Product Name	Product Type	Package
SP5T RF Switch	BGS15AN16	PG-TSNP-16-6

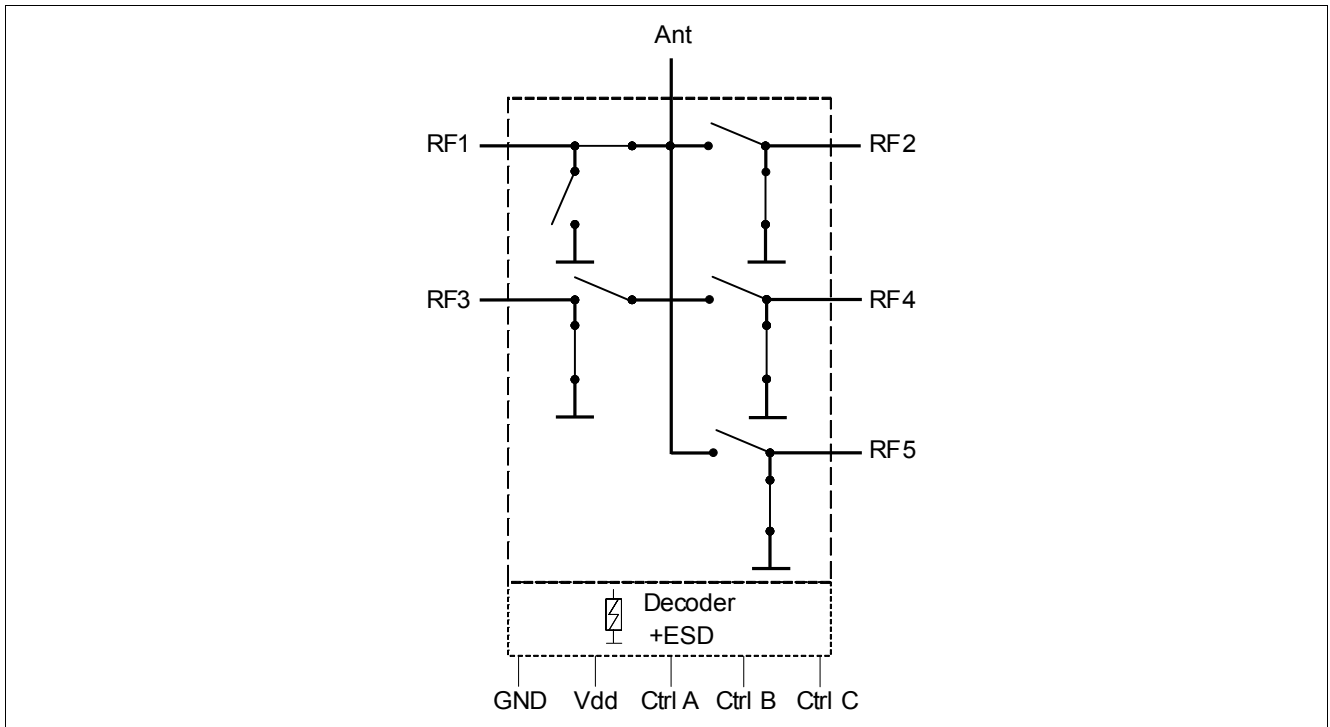

Figure 1 Functional Diagram

2 Signals Description

Table 1 Pin Description (top view)

Pin No.	Name	Pin Type	Buffer Type	Function
1	RX5	RX5		Rx RF port 5
2	RX4	I/O		Rx RF port 4
3	GND	GND		Ground
4	RX3	I/O		Rx RF port 3
5	GND	GND		Ground
6	RX2	I/O		Rx RF port 2
7	GND	GND		Ground
8	RX1	I/O		Rx RF port 1
9	GND	GND		Ground
10	ANT	I/O		Antenna port
11	DGND	GND		Ground
12	VDD	PWR		Vdd supply
13	V3	I		Control pin 3
14	V2	I		Control pin 2
15	V1	I		Control pin 1
16	GND	GND		Ground

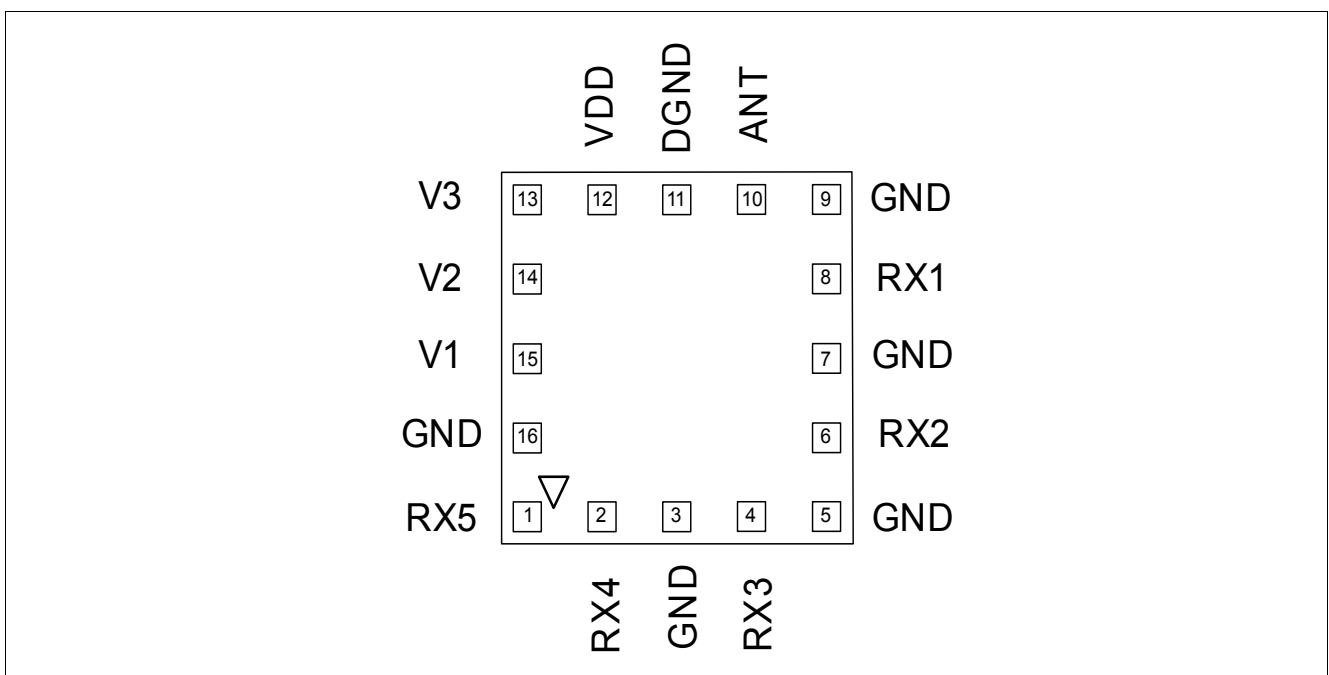

Figure 2 Pin Configuration (top view)

Table 2 Truth Table

Function	V1	V2	V3
Ant → RF1	1	0	0
Ant → RF2	0	1	0
Ant → RF3	0	0	1
Ant → RF4	1	0	1
Ant → RF5	1	1	1
Power down mode	0	0	0
All off	1	1	0
All off	0	1	1

3 Electrical Characteristics

Table 3 Absolute Maximum Ratings

Parameter	Symbol	Values			Unit	Note / Test Condition
		Min.	Typ.	Max.		
Storage Temperature Range	T_{stg}	-55	–	150	°C	–
DC Voltage at V_{dd} pin to GND	V_{DC}	–	–	5.5	V	–
DC Voltage at all other pins to GND	V_{DC}	–	–	3.6	V	–
Max RF power at antenna port, any RF port on	$P_{Ant IN max}$	–	–	32	dBm	50 Ω
Max. Input (Reverse) Power at antenna pin	P_{in}	–	–	30	dBm	50% duty cycle 50 Ω

Attention: Stresses above the max. values listed here may cause permanent damage to the device. Exposure to absolute maximum rating conditions for extended periods may affect device reliability. Maximum ratings are absolute ratings; exceeding only one of these values may cause irreversible damage to the integrated circuit.

Table 4 Operating Ranges

Parameter	Symbol	Values			Unit	Note / Test Condition
		Min.	Typ.	Max.		
Ambient Temperature	T_A	-30	–	85	°C	–
RF Frequency	f	0.1	–	3	GHz	–
Control Voltage low	V_{CtrlL}	-0.3	–	0.3	V	–
Control Voltage high	V_{CtrlH}	1.5	–	V_{dd}	V	$V_{dd} < 3.3V$
Supply Voltage	V_{dd}	2.85	–	4.7	V	–

Table 5 ESD Ratings

Parameter	Symbol	Values			Unit	Note / Test Condition
		Min.	Typ.	Max.		
ESD HBM, all ports	V_{max}	1	–	–	kV	all GND ports connected
ESD CDM, all ports	V_{max}	2	–	–	kV	–
ESD MM, all ports	V_{max}	100	–	–	V	–
ESD robustness IEC-61000-4-2, antenna port	V_{max}	8	–	–	kV	with external 27nH inductor

3.1 Electrical Specification

Test Conditions:

- Termination port impedance: $Z_0 = 50 \Omega$
- Temperature range: $T_A = -30 \text{ }^\circ\text{C} \dots +85 \text{ }^\circ\text{C}$
- Supply Voltage: $V_{dd} = 2.85 \text{ V} \dots 4.7 \text{ V}$
- $P_{in} = 0 \text{ dBm}$
- Across operating range of control voltages: $V_{ctrl} = 1.5 \dots 3.5 \text{ V}$
- Measured using external circuitry according application note AN259.

Table 6 Electrical Characteristics

Parameter	Symbol	Values			Unit	Note / Test Condition
		Min.	Typ.	Max.		
Insertion Loss						
824<f<960 MHz		–	0.34 ¹⁾	0.49	dB	–
1710<f<1980 MHz		–	0.55 ¹⁾	0.75	dB	RX1, RX5
1710<f<1980 MHz		–	0.5 ¹⁾	0.7	dB	RX 2-4
1980<f<2170 MHz		–	0.59 ¹⁾	0.79	dB	RX1, RX5
1980<f<2170 MHz		–	0.55 ¹⁾	0.75	dB	RX2-4
2170<f<2690 MHz		–	0.69 ¹⁾	0.89	dB	RX1, RX5
2170<f<2690 MHz		–	0.65 ¹⁾	0.85	dB	RX2-4
Inband ripple Rx ports (high bands)		–	0.05	0.1	dB	–
Inband ripple Rx ports (low bands)		–	0.03	0.1	dB	–
Return Loss¹⁾						
All ports @ 824 - 915 MHz		25	30	–	dB	–
All ports @ 1.71 - 2.69 GHz		14	20	–	dB	–
Isolation Ant – RF1,2,3,4,5						
824 - 915 MHz		35	40	–	dB	–
1.71 - 1.98 GHz		26	30	–	dB	–
1.98 - 2.17 GHz		24	30	–	dB	–
2.17 - 2.69 GHz		24	27	–	dB	–
Isolation RF1,2,3 – RF1,2,3,4,5						
824 - 915 MHz		32	35	–	dB	–
1.71 - 1.98 GHz		26	28	–	dB	–
1.98 - 2.17 GHz		25	28	–	dB	–
2.17 - 2.69 GHz		21	25	–	dB	–
Isolation RF Ports – V_{dd}, V_{ctrl}						
0.9 GHz		40	30	–	dB	–
2 GHz		20	20	–	dB	–

1) $T_A = 25 \text{ }^\circ\text{C}$ and $V_{dd} = 3.5 \text{ V}$

Table 7 Electrical Characteristics (cont'd)

Parameter	Symbol	Values			Unit	Note / Test Condition
		Min.	Typ.	Max.		
Input Intercept Point Requirements - IMD2¹⁾						
Tx=15 dBm@ ant port, Int=-15 dBm @ant port (TX Freq = 824 - 915 MHz)		–	-110	-104	dBm	–
Tx=10 dBm@ ant port, Int=-15 dBm @ant port (TX Freq=1710 - 1980 MHz)		–	-110	-104	dBm	–
Input Intercept Point Requirements – IMD3¹⁾						
Tx=15 dBm@ ant port, Int= -15 dBm @ant port(TX Freq = 824 - 915 MHz)		–	-110	-104	dBm	–
Tx=10 dBm@ ant port, Int=-15 dBm @ant port (TX Freq=1710 - 1980 MHz)		–	-110	-104	dBm	–
Harmonic Generation RF ports up to 12.75 GHz¹⁾						
Pin (UMTS) = 23 dBm, Duty Cycle = 100%, unused RF pins = any load, VSWR = 4:1		–	–	–	–	–
824 to 960 MHz		–	–	-46	dBm	–
1920 to 1980 MHz		–	–	-46	dBm	–
Harmonic Generation RF port up to 12.75 GHz¹⁾						
Pin = 30 dBm at low band, 22 dBm at high band, Duty Cycle = 25%		–	–	–	–	–
824 to 960 MHz, Third Harmonic		–	-50	-42	dBm	–
824 to 960 MHz, all other Harmonics up to 12.75 GHz		–	-50	-44	dBm	–
1920 to 1980 MHz		–	-50	-44	dBm	–
Switching Time and Current Consumption						
On/Off Switching Time (10-90%) RF		0.3	1	3	µs	–
Boost Converter Settling Time		–	10	25	µs	after power down mode
Current Consumption at Vdd Pin		50	75	100	µA	–
Current Consumption at Vctrl Pins		0.1	1	30	µA	–
Current Consumption at power down mode		–	–	1	µA	–

1) $T_A = 25\text{ }^\circ\text{C}$ and $V_{dd} = 3.5\text{ V}$

4 Package Outline

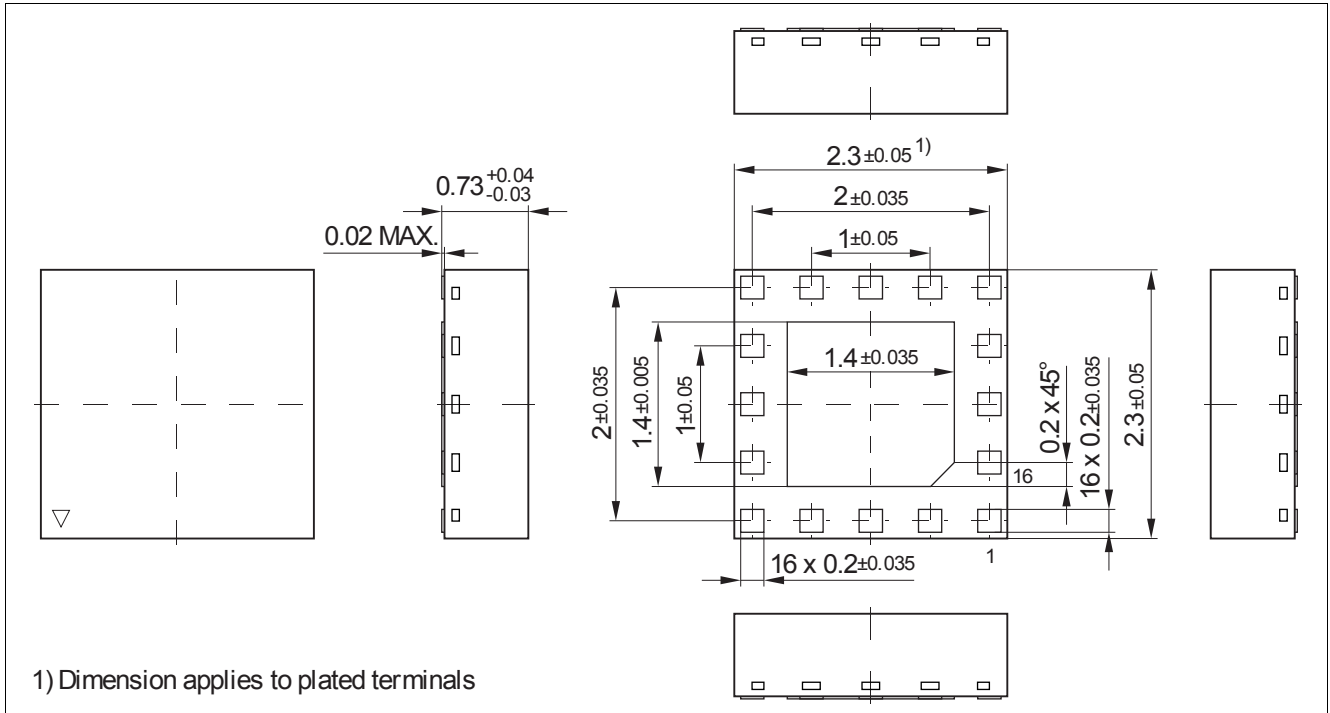

Figure 3 Package Outline

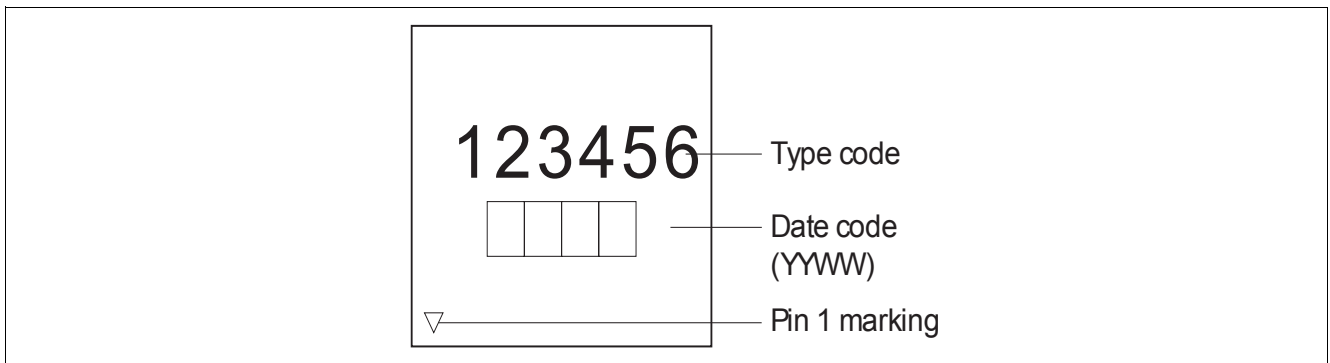

Figure 4 Pin Marking

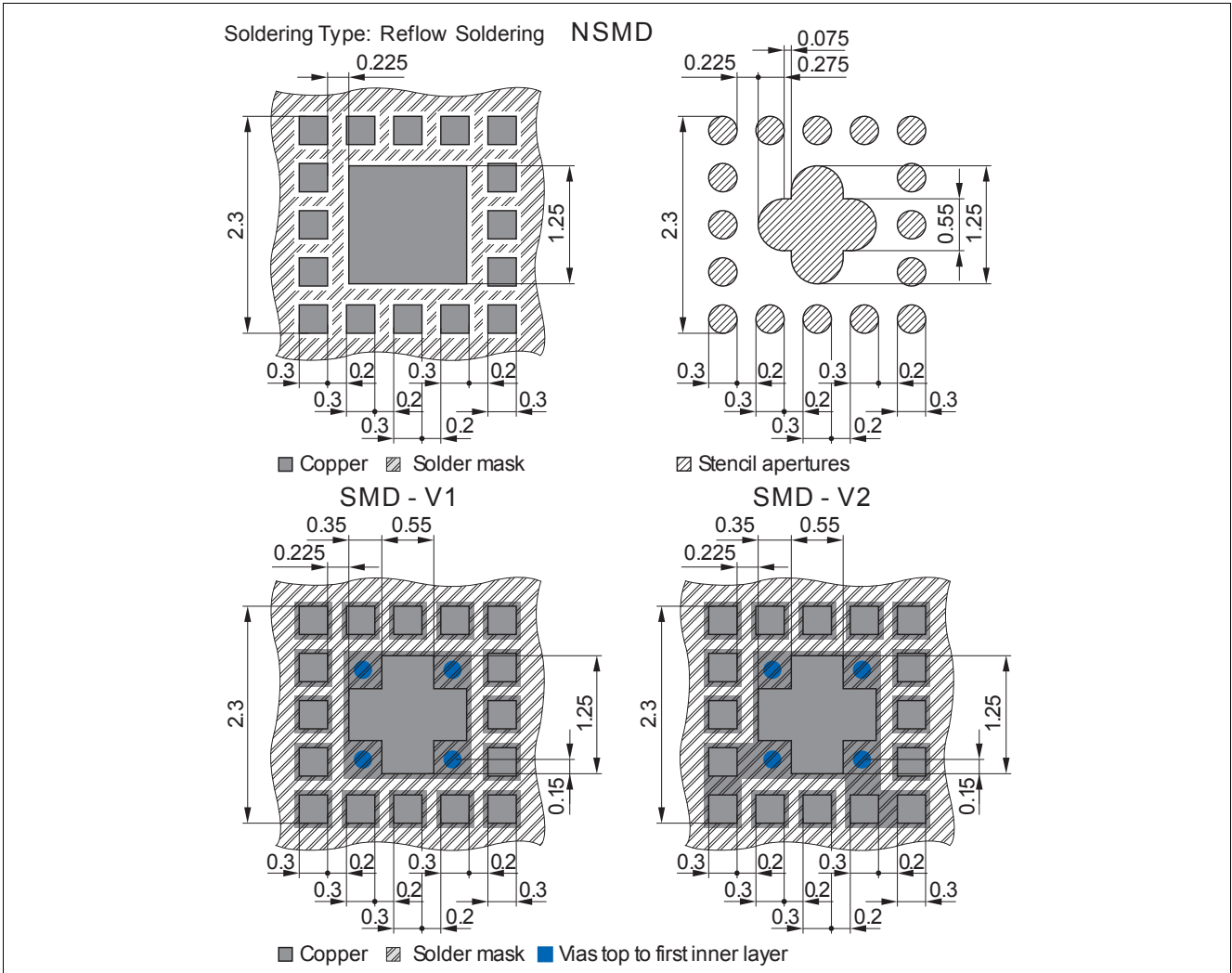

Figure 5 Land Pattern and Stencil Mask

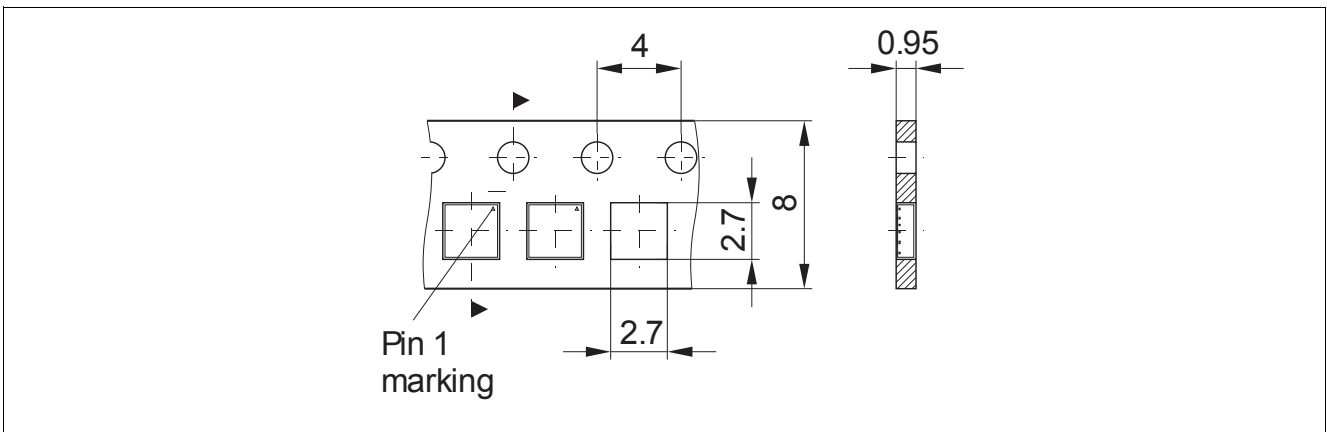

Figure 6 Tape Drawing for PG-TSNP-16-6

www.infineon.com

Published by Infineon Technologies AG

Компания «Life Electronics» занимается поставками электронных компонентов импортного и отечественного производства от производителей и со складов крупных дистрибьюторов Европы, Америки и Азии.

С конца 2013 года компания активно расширяет линейку поставок компонентов по направлению коаксиальный кабель, кварцевые генераторы и конденсаторы (керамические, пленочные, электролитические), за счёт заключения дистрибьюторских договоров

Мы предлагаем:

- Конкуренспособные цены и скидки постоянным клиентам.
- Специальные условия для постоянных клиентов.
- Подбор аналогов.
- Поставку компонентов в любых объемах, удовлетворяющих вашим потребностям.
- Приемлемые сроки поставки, возможна ускоренная поставка.
- Доставку товара в любую точку России и стран СНГ.
- Комплексную поставку.
- Работу по проектам и поставку образцов.
- Формирование склада под заказчика.
- Сертификаты соответствия на поставляемую продукцию (по желанию клиента).
- Тестирование поставляемой продукции.
- Поставку компонентов, требующих военную и космическую приемку.
- Входной контроль качества.
- Наличие сертификата ISO.

В составе нашей компании организован Конструкторский отдел, призванный помогать разработчикам, и инженерам.

Конструкторский отдел помогает осуществить:

- Регистрацию проекта у производителя компонентов.
- Техническую поддержку проекта.
- Защиту от снятия компонента с производства.
- Оценку стоимости проекта по компонентам.
- Изготовление тестовой платы монтаж и пусконаладочные работы.



Тел: +7 (812) 336 43 04 (многоканальный)
Email: org@lifeelectronics.ru