

# MC68QH302

## *Advance Information*

# MC68QH302 Quad HDLC Integrated Multiprotocol Processor Technical Summary

The MC68QH302, quad HDLC integrated multiprotocol processor, is based on the three-SCC MC68302 family of chips with the addition of the QH protocol and two extra serial DMA channels. The QH302 supports a total of four independent communications channels, handling two HDLC or transparent channels on SCC1; see Figure 1 for a block diagram.

In non-QH mode, the QH302 can be used in standard 302 applications as well.

To locate any published errata or updates for this document, refer to the website at <http://www.mot.com/netcomm>.



This document contains information on a new product under development. Freescale Semiconductor, Inc. reserves the right to change or discontinue this product without notice.

© 1997. All rights reserved.

**For More Information On This Product,  
Go to: [www.freescale.com](http://www.freescale.com)**

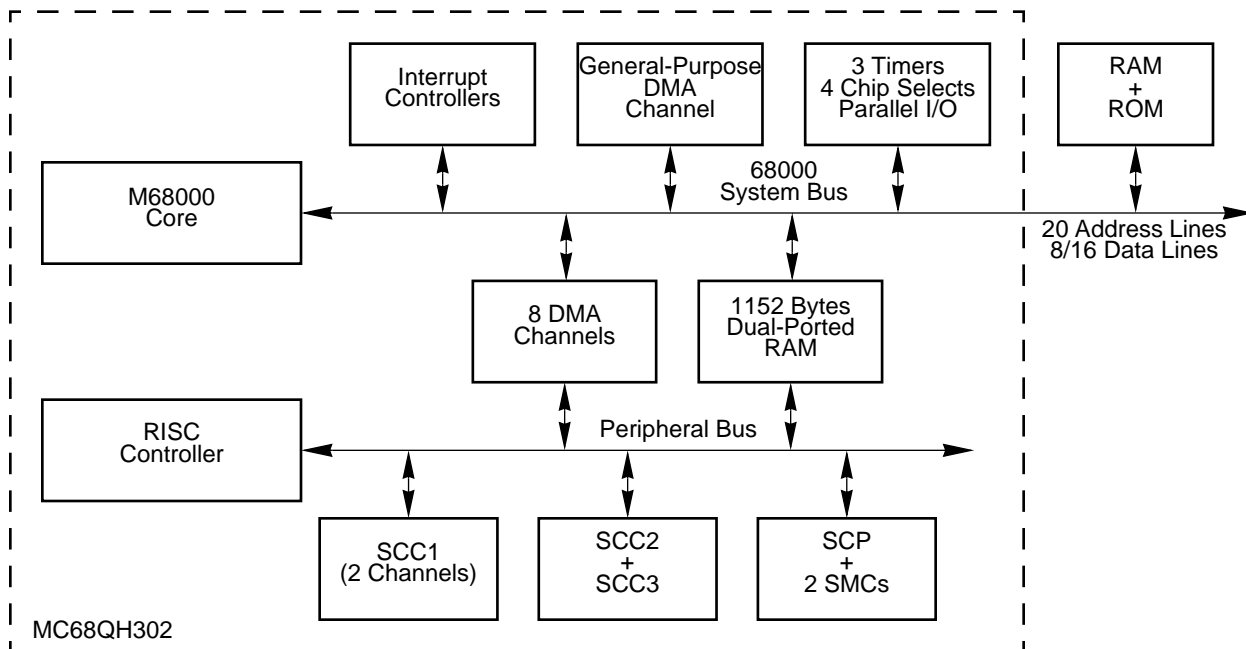

**Figure 1. MC68QH302 Block Diagram**

The MC68QH302 supports a full ISDN basic rate interface with one serial channel left over to communicate with the DTE as shown in Figure 2. The dual-channel SCC1 is used to support the two B channels.

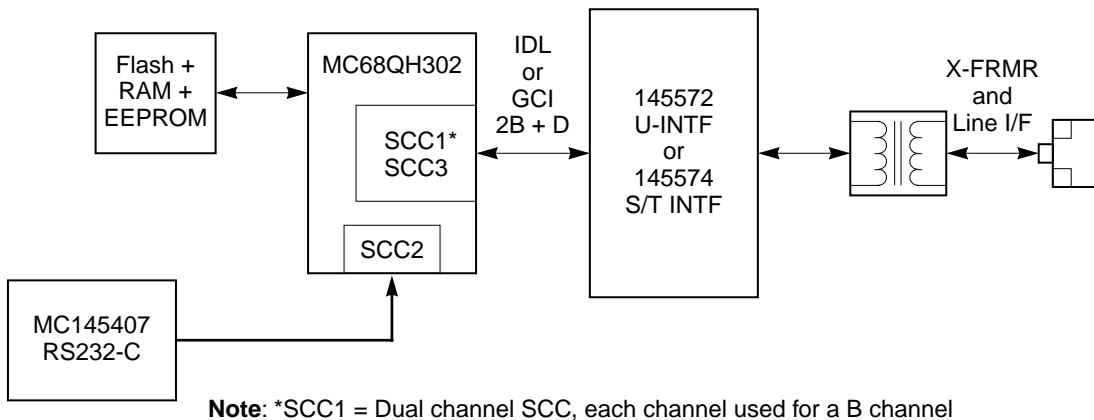

**Figure 2. MC68QH302 Supporting a Full ISDN Basic Rate Interface**

## 1.1 FEATURES

The main features of the MC68QH302 are as follows (**new features indicated in bold**):

- MC68000/MC68008 microprocessor core (may be disabled to use the IMP as a peripheral)
- Serial interface block including:
  - Independent direct memory access (IDMA) controller
  - Interrupt controller with two modes of operation
  - Parallel I/O ports, some with interrupt capability
  - On-chip 1152 bytes of dual-ported RAM
  - Three timers, including a software watchdog timer
  - Four programmable chip-select lines with wait-state logic
  - Programmable address mapping of dual-ported RAM and IMP registers
  - On-chip clock generator with an output clock signal
  - System control
    - System control register
    - Bus arbitration logic with low-interrupt latency support
    - Hardware watchdog for monitoring bus activity
    - Low power (standby) modes
    - Disable CPU logic (M68000)
    - Freeze control for debugging selected on-chip peripherals
    - DRAM refresh controller
- CP including:
  - Main controller (RISC processor)
  - Three physical full-duplex serial communication controllers (SCCs) with the following protocols:
    - HDLC/SDLC
    - UART
    - Totally transparent
    - V.110
  - **SCC1 can support two logical HDLC or transparent channels running QH protocol**
  - **Eight serial DMA channels dedicated to the four serial channels**
  - Capability to send /receive up to eight buffers/frames without M68000 core intervention
  - Flexible physical interface accessible by SCCs for interchip digital link (IDL), general circuit interface (GCI, also called IOM2), pulse code modulation (PCM), and nonmultiplexed serial interface (NMSI) operation
  - Serial communication port (SCP) for synchronous communication
  - Serial management controllers (SMCs) for IDL and GCI channels
- Application development system available with M68302FADS.

## 1.2 MC68QH302 Ordering Information

Table 1 identifies operating frequencies available for the MC68QH302.

**Table 1. MC68QH302 Package/Frequency Availability**

Package Type	Operating Voltage	Frequency (MHz)	Temperature	Order Number
144-pin thin quad flat pack (PV suffix)	5 V	16.67	0° C to 70° C	MC68QH302PV16
		20		MC68QH302PV20
		25		MC68QH302PV25

The documents listed in Table 2 contain detailed information on the MC68QH302. These documents can be obtained from the Literature Distribution Centers at the addresses listed on the back page. Visit the website at <http://www.mot.com/netcomm/> for more information.

**Table 2. Documentation**

Document Title	Order Number	Contents
MC68302 User's Manual	MC68302UM/AD	Detailed information for design
M68000 Family Programmer's Reference Manual	M68000PM/AD	M68000 family instruction set
The 68K Source	BR729/D	Independent vendor listing supporting software and development tools
The MC68QH302 Supplement to MC68302 User's Manual	MC68QH302SUPL/AD	Highlights implementation-specific features of the MC68QH302, and discusses how they differ from the MC68302.



**Home Page:**

[www.freescale.com](http://www.freescale.com)

**email:**

[support@freescale.com](mailto:support@freescale.com)

**USA/Europe or Locations Not Listed:**

Freescale Semiconductor  
 Technical Information Center, CH370  
 1300 N. Alma School Road  
 Chandler, Arizona 85224  
 (800) 521-6274  
 480-768-2130

[support@freescale.com](mailto:support@freescale.com)

**Europe, Middle East, and Africa:**

Freescale Halbleiter Deutschland GmbH  
 Technical Information Center  
 Schatzbogen 7  
 81829 Muenchen, Germany  
 +44 1296 380 456 (English)  
 +46 8 52200080 (English)  
 +49 89 92103 559 (German)  
 +33 1 69 35 48 48 (French)

[support@freescale.com](mailto:support@freescale.com)

**Japan:**

Freescale Semiconductor Japan Ltd.  
 Headquarters  
 ARCO Tower 15F  
 1-8-1, Shimo-Meguro, Meguro-ku  
 Tokyo 153-0064, Japan  
 0120 191014  
 +81 2666 8080

[support.japan@freescale.com](mailto:support.japan@freescale.com)

**Asia/Pacific:**

Freescale Semiconductor Hong Kong Ltd.  
 Technical Information Center  
 2 Dai King Street  
 Tai Po Industrial Estate,  
 Tai Po, N.T., Hong Kong  
 +800 2666 8080

[support.asia@freescale.com](mailto:support.asia@freescale.com)

**For Literature Requests Only:**

Freescale Semiconductor  
 Literature Distribution Center  
 P.O. Box 5405  
 Denver, Colorado 80217  
 (800) 441-2447  
 303-675-2140  
 Fax: 303-675-2150  
[LDCForFreescaleSemiconductor@hibbertgroup.com](mailto:LDCForFreescaleSemiconductor@hibbertgroup.com)

RoHS-compliant and/or Pb-free versions of Freescale products have the functionality and electrical characteristics of their non-RoHS-compliant and/or non-Pb-free counterparts. For further information, see <http://www.freescale.com> or contact your Freescale sales representative.

For information on Freescale's Environmental Products program, go to <http://www.freescale.com/epp>.

Information in this document is provided solely to enable system and software implementers to use Freescale Semiconductor products. There are no express or implied copyright licenses granted hereunder to design or fabricate any integrated circuits or integrated circuits based on the information in this document. Freescale Semiconductor reserves the right to make changes without further notice to any products herein. Freescale Semiconductor makes no warranty, representation or guarantee regarding the suitability of its products for any particular purpose, nor does Freescale Semiconductor assume any liability arising out of the application or use of any product or circuit, and specifically disclaims any and all liability, including without limitation consequential or incidental damages. "Typical" parameters which may be provided in Freescale Semiconductor data sheets and/or specifications can and do vary in different applications and actual performance may vary over time. All operating parameters, including "Typicals" must be validated for each customer application by customer's technical experts. Freescale Semiconductor does not convey any license under its patent rights nor the rights of others. Freescale Semiconductor products are not designed, intended, or authorized for use as components in systems intended for surgical implant into the body, or other applications intended to support or sustain life, or for any other application in which the failure of the Freescale Semiconductor product could create a situation where personal injury or death may occur. Should Buyer purchase or use Freescale Semiconductor products for any such unintended or unauthorized application, Buyer shall indemnify and hold Freescale Semiconductor and its officers, employees, subsidiaries, affiliates, and distributors harmless against all claims, costs, damages, and expenses, and reasonable attorney fees arising out of, directly or indirectly, any claim of personal injury or death associated with such unintended or unauthorized use, even if such claim alleges that Freescale Semiconductor was negligent regarding the design or manufacture of the part.



Компания «Life Electronics» занимается поставками электронных компонентов импортного и отечественного производства от производителей и со складов крупных дистрибьюторов Европы, Америки и Азии.

С конца 2013 года компания активно расширяет линейку поставок компонентов по направлению коаксиальный кабель, кварцевые генераторы и конденсаторы (керамические, пленочные, электролитические), за счёт заключения дистрибьюторских договоров

Мы предлагаем:

- Конкурентоспособные цены и скидки постоянным клиентам.
- Специальные условия для постоянных клиентов.
- Подбор аналогов.
- Поставку компонентов в любых объемах, удовлетворяющих вашим потребностям.
- Приемлемые сроки поставки, возможна ускоренная поставка.
- Доставку товара в любую точку России и стран СНГ.
- Комплексную поставку.
- Работу по проектам и поставку образцов.
- Формирование склада под заказчика.
- Сертификаты соответствия на поставляемую продукцию (по желанию клиента).
- Тестирование поставляемой продукции.
- Поставку компонентов, требующих военную и космическую приемку.
- Входной контроль качества.
- Наличие сертификата ISO.

В составе нашей компании организован Конструкторский отдел, призванный помогать разработчикам, и инженерам.

Конструкторский отдел помогает осуществить:

- Регистрацию проекта у производителя компонентов.
- Техническую поддержку проекта.
- Защиту от снятия компонента с производства.
- Оценку стоимости проекта по компонентам.
- Изготовление тестовой платы монтаж и пусконаладочные работы.



Тел: +7 (812) 336 43 04 (многоканальный)  
Email: [org@lifeelectronics.ru](mailto:org@lifeelectronics.ru)