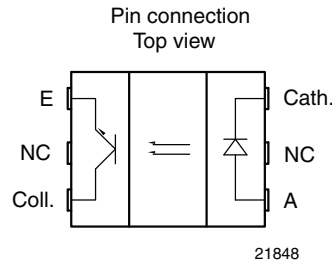




Subminiature Transmissive Optical Sensor with Transistor Output



FEATURES

- Package type: surface mount
- Detector type: phototransistor
- Dimensions (L x W x H in mm): 5.5 x 4 x 4
- AEC-Q101 qualified
- Gap (in mm): 3
- Aperture (in mm): 0.3
- Typical output current under test: $I_C = 1.6 \text{ mA}$
- Emitter wavelength: 950 nm
- Released for high operating temperatures up to 125 °C
- Moisture sensitivity level (MSL): 1
- Material categorization: For definitions of compliance please see www.vishay.com/doc?99912

AUTOMOTIVE GRADE



RoHS COMPLIANT GREEN (5-2008)

DESCRIPTION

The TCPT1350X01 is a compact transmissive sensor that includes an infrared emitter and a phototransistor detector, located face-to-face in a surface mount package. TCPT1350X01 is especially designed to meet high operating temperature requirements and is released for operating temperature ranges from - 40 °C to + 125 °C.

APPLICATIONS

- Automotive optical sensors
- Accurate position sensor for encoder
- Detection of motion speed

| PRODUCT SUMMARY | | | | |
|-----------------|----------------|---------------------|---|-------------------------------------|
| PART NUMBER | GAP WIDTH (mm) | APERTURE WIDTH (mm) | TYPICAL OUTPUT CURRENT UNDER TEST ⁽¹⁾ (mA) | DAYLIGHT BLOCKING FILTER INTEGRATED |
| TCPT1350X01 | 3 | 0.3 | 1.6 | No |

Note

- Conditions like in table basic characteristics/coupler

| ORDERING INFORMATION | | | |
|----------------------|---------------|------------------------------|----------------|
| ORDERING CODE | PACKAGING | VOLUME ⁽¹⁾ | REMARKS |
| TCPT1350X01 | Tape and reel | MOQ: 2000 pcs, 2000 pcs/reel | Drypack, MSL 1 |

Note

- MOQ: minimum order quantity



| ABSOLUTE MAXIMUM RATINGS (T _{amb} = 25 °C, unless otherwise specified) | | | | |
|---|---|------------------|---------------|------|
| PARAMETER | TEST CONDITION | SYMBOL | VALUE | UNIT |
| COUPLER | | | | |
| Total power dissipation | T _{amb} ≤ 125 °C | P _{tot} | 37.5 | mW |
| Junction temperature | | T _j | 140 | °C |
| Ambient temperature range | | T _{amb} | - 40 to + 125 | °C |
| Storage temperature range | | T _{stg} | - 40 to + 125 | °C |
| Soldering temperature | In accordance with fig. 16 | T _{sd} | 260 | °C |
| INPUT (EMITTER) | | | | |
| Reverse voltage | | V _R | 5 | V |
| Forward current | T _{amb} ≤ 125 °C | I _F | 25 | mA |
| Forward surge current | t _p ≤ 10 μs | I _{FSM} | 200 | mA |
| Power dissipation | T _{amb} ≤ 125 °C | P _V | 37.5 | mW |
| OUTPUT (DETECTOR) | | | | |
| Collector emitter voltage | | V _{CEO} | 20 | V |
| Emitter collector voltage | | V _{ECO} | 7 | V |
| Collector current | | I _C | 20 | mA |
| Collector dark current | T _{amb} = 85 °C, V _{CE} = 5 V | I _{CEO} | 3.3 | μA |

ABSOLUTE MAXIMUM RATINGS

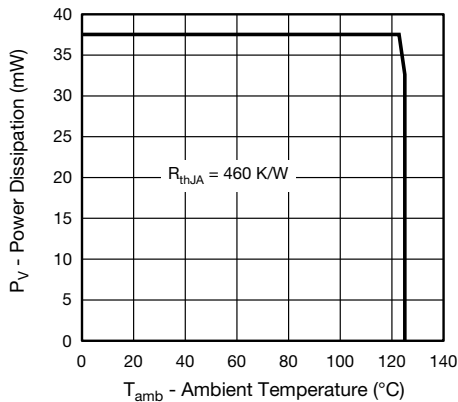


Fig. 1 - Power Dissipation Limit vs. Ambient Temperature

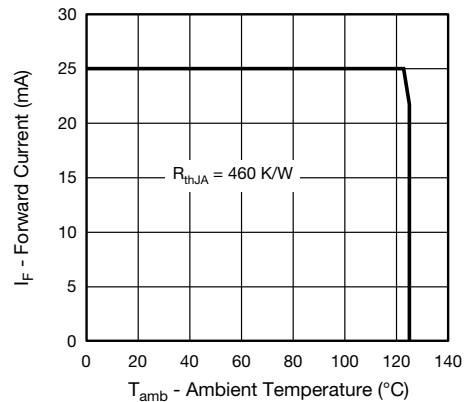


Fig. 2 - Forward Current Limit vs. Ambient Temperature

| BASIC CHARACTERISTICS ($T_{amb} = 25\text{ }^{\circ}\text{C}$, unless otherwise specified) | | | | | | |
|---|---|-------------|------|------|------|---------------|
| PARAMETER | TEST CONDITION | SYMBOL | MIN. | TYP. | MAX. | UNIT |
| COUPLER | | | | | | |
| Collector current | $V_{CE} = 5\text{ V}$, $I_F = 15\text{ mA}$ | I_C | 0.7 | 1.6 | | mA |
| Collector emitter saturation voltage | $I_F = 15\text{ mA}$, $I_C = 0.2\text{ mA}$ | V_{CEsat} | | | 0.4 | V |
| INPUT (EMITTER) | | | | | | |
| Forward voltage | $I_F = 15\text{ mA}$ | V_F | 1 | 1.2 | 1.4 | V |
| Reverse current | $V_R = 5\text{ V}$ | I_R | | | 10 | μA |
| Junction capacitance | $V_R = 0\text{ V}$, $f = 1\text{ MHz}$ | C_j | | 25 | | pF |
| OUTPUT (DETECTOR) | | | | | | |
| Collector emitter voltage I_C | $I_C = 1\text{ mA}$ | V_{CEO} | 20 | | | V |
| Emitter collector voltage | $I_E = 100\text{ }\mu\text{A}$ | V_{ECO} | 7 | | | V |
| Collector dark current | $V_{CE} = 25\text{ V}$, $I_F = 0\text{ A}$, $E = 0\text{ lx}$ | I_{CEO} | | 1 | 100 | nA |
| SWITCHING CHARACTERISTICS | | | | | | |
| Rise time | $I_C = 0.7\text{ mA}$, $V_{CE} = 5\text{ V}$, $R_L = 100\text{ }\Omega$ (see figure 3) | t_r | | 9 | 150 | μs |
| Fall time | $I_C = 0.7\text{ mA}$, $V_{CE} = 5\text{ V}$, $R_L = 100\text{ }\Omega$ (see figure 3) | t_f | | 16 | 150 | μs |

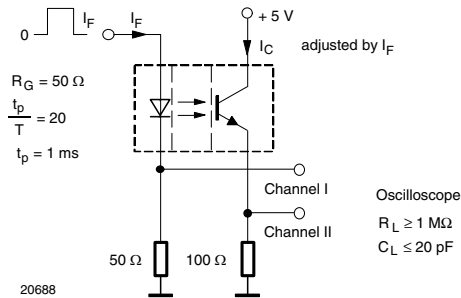
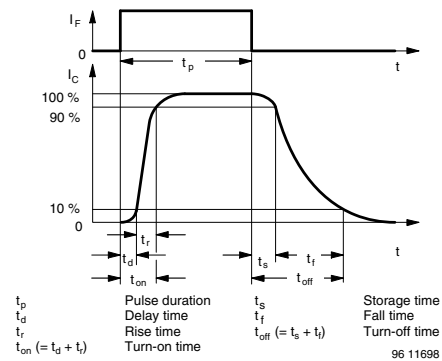

 Fig. 3 - Test Circuit for t_r and t_f


Fig. 4 - Switching Times

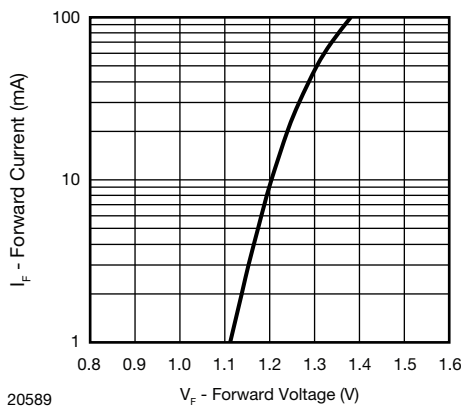
BASIC CHARACTERISTICS ($T_{amb} = 25\text{ }^{\circ}\text{C}$, unless otherwise specified)


Fig. 5 - Forward Current vs. Forward Voltage

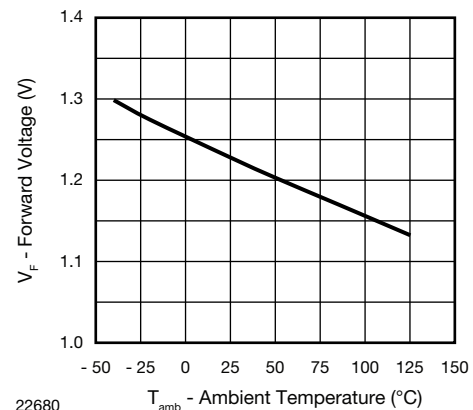


Fig. 6 - Forward Voltage vs. Ambient Temperature

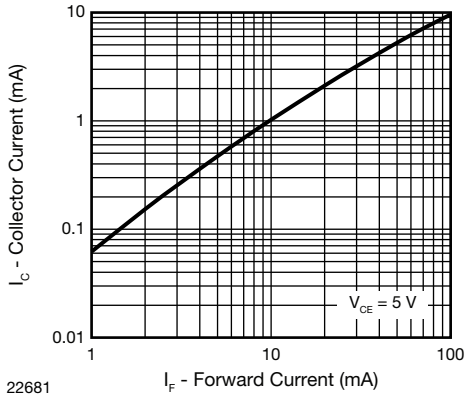


Fig. 7 - Collector Current vs. Forward Current

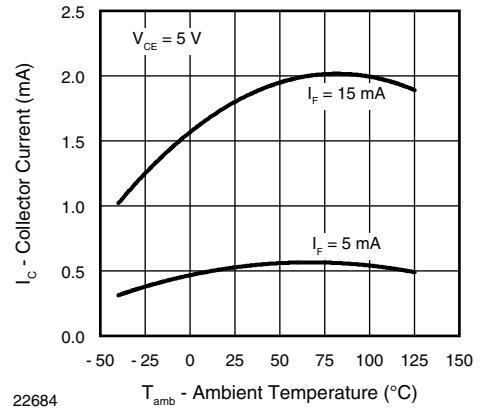


Fig. 10 - Collector Current vs. Ambient Temperature

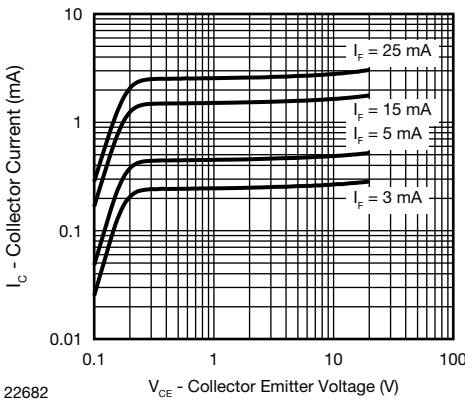


Fig. 8 - Collector Current vs. Collector Emitter Voltage

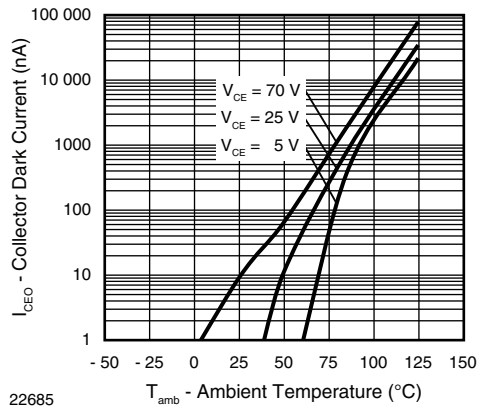


Fig. 11 - Collector Dark Current vs. Ambient Temperature

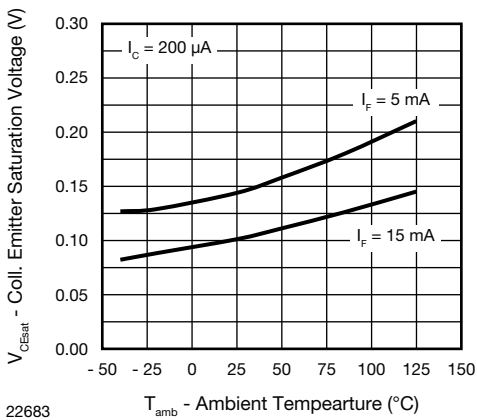


Fig. 9 - Collector Emitter Saturation Voltage vs. Ambient Temperature

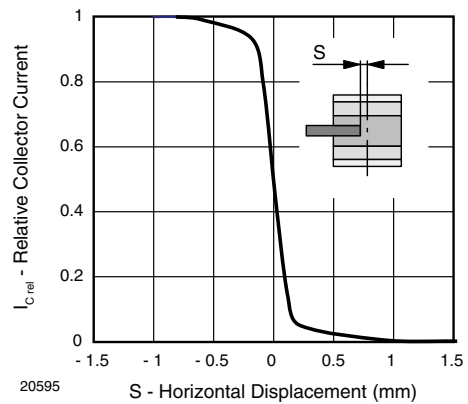


Fig. 12 - Relative Collector Current vs. Horizontal Displacement

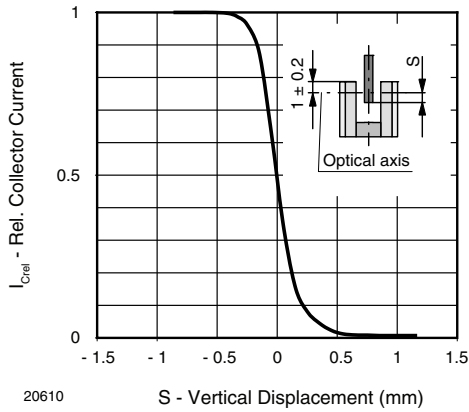


Fig. 13 - Relative Collector Current vs. Vertical Displacement

REFLOW SOLDER PROFILE

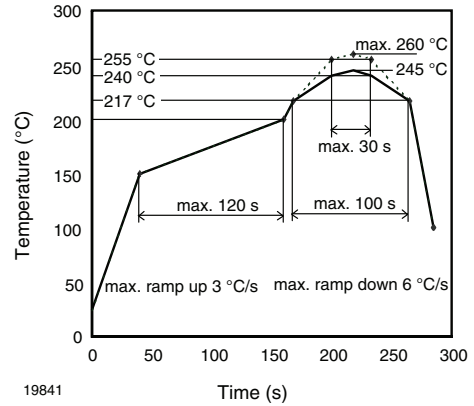


Fig. 16 - Lead (Pb)-free Reflow Solder Profile acc. J-STD-020

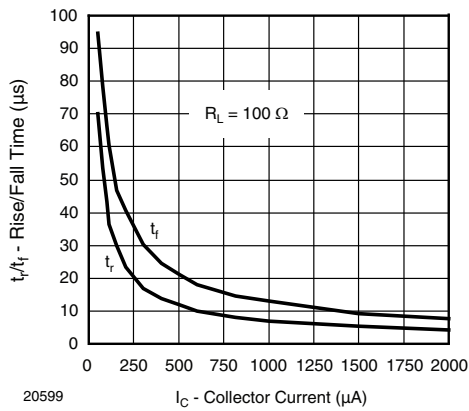


Fig. 14 - Rise/Fall Time vs. Collector Current

FLOOR LIFE

No time limit.
Moisture sensitivity level (MSL) 1, acc. JEDEC, J-STD-020.

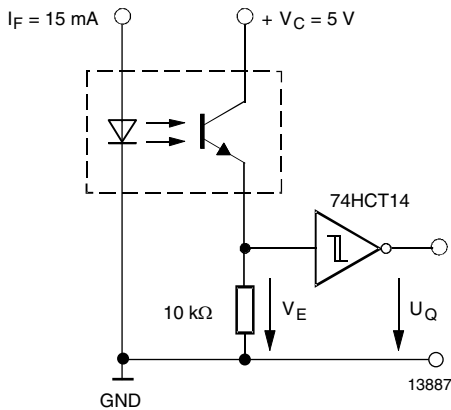
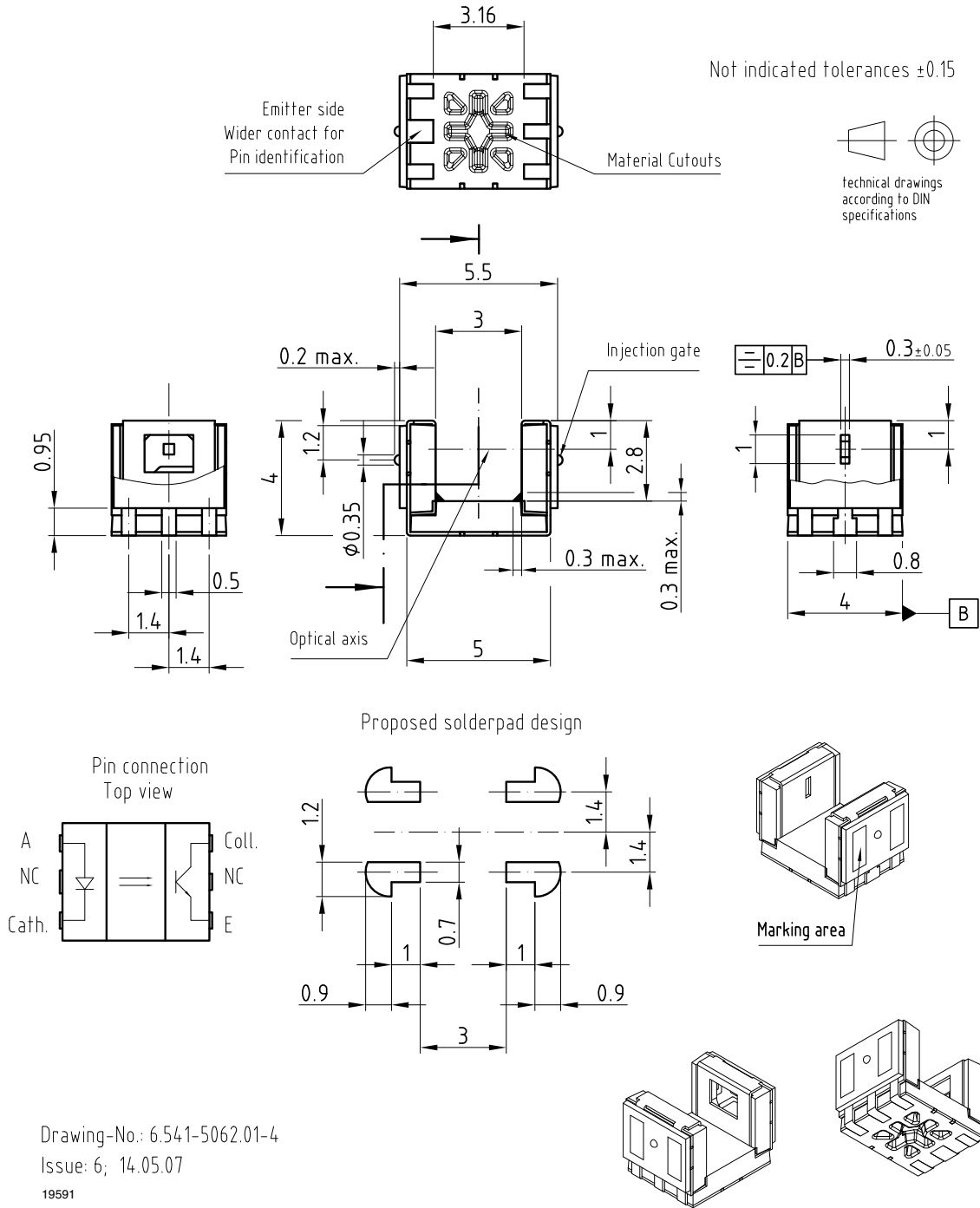


Fig. 15 - Application example

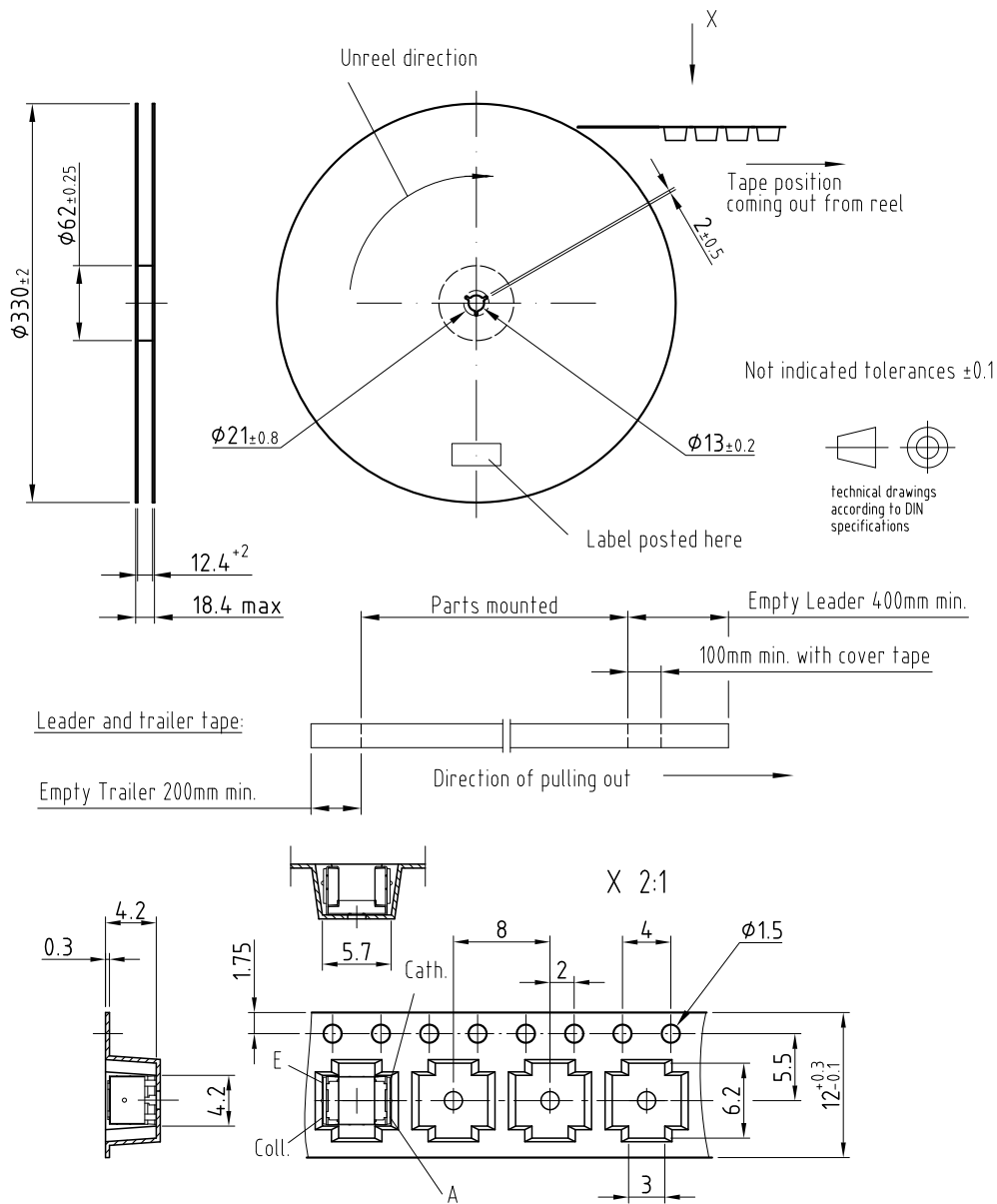


PACKAGE DIMENSIONS in millimeters



PACKAGE DIMENSIONS in millimeters

Volume/reel = 2000 pcs



Drawing-No.: 9.800-5092.02-4

Issue: 1; 14.05.07

20601

Packaging and Ordering Information

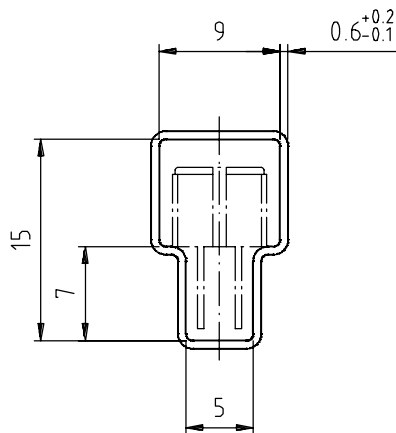
| PART NUMBER | MOQ ⁽¹⁾ | PCS PER TUBE | TUBE SPEC. (FIGURE) | CONSTITUENTS (FORMS) |
|---------------|--------------------|--------------|---------------------|----------------------|
| CNY70 | 4000 | 80 | 1 | 28 |
| TCPT1300X01 | 2000 | Reel | (2) | 29 |
| TCRT1000 | 1000 | Bulk | - | 26 |
| TCRT1010 | 1000 | Bulk | - | 26 |
| TCRT5000 | 4500 | 50 | 2 | 27 |
| TCRT5000L | 2400 | 48 | 3 | 27 |
| TCST1030 | 5200 | 65 | 5 | 24 |
| TCST1030L | 2600 | 65 | 6 | 24 |
| TCST1103 | 1020 | 85 | 4 | 24 |
| TCST1202 | 1020 | 85 | 4 | 24 |
| TCST1230 | 4800 | 60 | 7 | 24 |
| TCST1300 | 1020 | 85 | 4 | 24 |
| TCST2103 | 1020 | 85 | 4 | 24 |
| TCST2202 | 1020 | 85 | 4 | 24 |
| TCST2300 | 1020 | 85 | 4 | 24 |
| TCST5250 | 4860 | 30 | 8 | 24 |
| TCUT1300X01 | 2000 | Reel | (2) | 29 |
| TCZT8020-PAER | 2500 | Bulk | - | 22 |

Notes

(1) MOQ: minimum order quantity

(2) Please refer to datasheets

TUBE SPECIFICATION FIGURES



With rubber stopper

Tolerance: ±0.5mm

Length: 575±1mm

Drawing-No.: 9.700-5097.01-4

Issue: 1; 25.02.00

15198

Fig. 1

Packaging and Ordering Information

Vishay Semiconductors Packaging and Ordering Information



Drawing-No.: 9.700-5139.01-4
Issue: 1; 10.05.00

Drawing refers to following types: TCRT 5000

15210

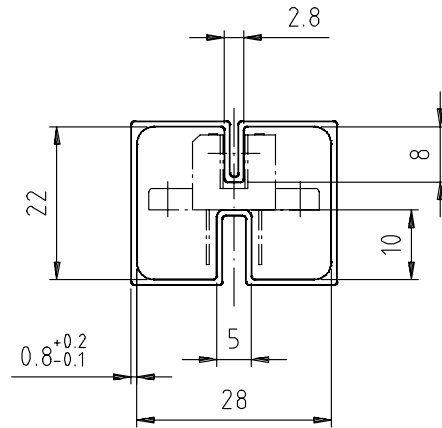
Fig. 2



Drawing-No.: 9.700-5178.01-4
Issue: 1; 25.02.00

15201

Fig. 3

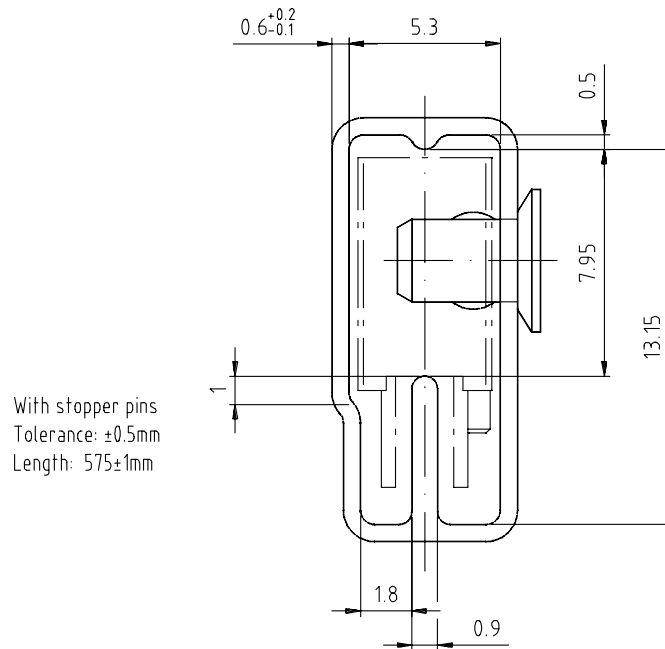


With rubber stopper
Tolerance: ±0.5mm
Length: 575±1mm

Drawing-No.: 9.700-5100.01-4
Issue: 1; 25.02.00

15199

Fig. 4



With stopper pins
Tolerance: ±0.5mm
Length: 575±1mm

Drawing-No.: 9.700-5140.01-4
Issue: 1; 25.02.00

15202

Fig. 5



Drawing-No.: 9.700-5205.01-4
Issue: 1; 25.02.00

15196

Fig. 6



Drawing-No.: 9.700-5245.01-4
Issue: 1; 25.02.00

15195

Fig. 7



Drawing-No.: 9.700-5222.01-4
 Issue: 2; 19.11.04
 20257

With stopper pins
 Tolerance: $\pm 0.5\text{mm}$
 Length: $450 \pm 1\text{mm}$
 All dimensions in mm

Fig. 8



Disclaimer

ALL PRODUCT, PRODUCT SPECIFICATIONS AND DATA ARE SUBJECT TO CHANGE WITHOUT NOTICE TO IMPROVE RELIABILITY, FUNCTION OR DESIGN OR OTHERWISE.

Vishay Intertechnology, Inc., its affiliates, agents, and employees, and all persons acting on its or their behalf (collectively, "Vishay"), disclaim any and all liability for any errors, inaccuracies or incompleteness contained in any datasheet or in any other disclosure relating to any product.

Vishay makes no warranty, representation or guarantee regarding the suitability of the products for any particular purpose or the continuing production of any product. To the maximum extent permitted by applicable law, Vishay disclaims (i) any and all liability arising out of the application or use of any product, (ii) any and all liability, including without limitation special, consequential or incidental damages, and (iii) any and all implied warranties, including warranties of fitness for particular purpose, non-infringement and merchantability.

Statements regarding the suitability of products for certain types of applications are based on Vishay's knowledge of typical requirements that are often placed on Vishay products in generic applications. Such statements are not binding statements about the suitability of products for a particular application. It is the customer's responsibility to validate that a particular product with the properties described in the product specification is suitable for use in a particular application. Parameters provided in datasheets and/or specifications may vary in different applications and performance may vary over time. All operating parameters, including typical parameters, must be validated for each customer application by the customer's technical experts. Product specifications do not expand or otherwise modify Vishay's terms and conditions of purchase, including but not limited to the warranty expressed therein.

Except as expressly indicated in writing, Vishay products are not designed for use in medical, life-saving, or life-sustaining applications or for any other application in which the failure of the Vishay product could result in personal injury or death. Customers using or selling Vishay products not expressly indicated for use in such applications do so at their own risk. Please contact authorized Vishay personnel to obtain written terms and conditions regarding products designed for such applications.

No license, express or implied, by estoppel or otherwise, to any intellectual property rights is granted by this document or by any conduct of Vishay. Product names and markings noted herein may be trademarks of their respective owners.

Material Category Policy

Vishay Intertechnology, Inc. hereby certifies that all its products that are identified as RoHS-Compliant fulfill the definitions and restrictions defined under Directive 2011/65/EU of The European Parliament and of the Council of June 8, 2011 on the restriction of the use of certain hazardous substances in electrical and electronic equipment (EEE) - recast, unless otherwise specified as non-compliant.

Please note that some Vishay documentation may still make reference to RoHS Directive 2002/95/EC. We confirm that all the products identified as being compliant to Directive 2002/95/EC conform to Directive 2011/65/EU.

Vishay Intertechnology, Inc. hereby certifies that all its products that are identified as Halogen-Free follow Halogen-Free requirements as per JEDEC JS709A standards. Please note that some Vishay documentation may still make reference to the IEC 61249-2-21 definition. We confirm that all the products identified as being compliant to IEC 61249-2-21 conform to JEDEC JS709A standards.

Компания «Life Electronics» занимается поставками электронных компонентов импортного и отечественного производства от производителей и со складов крупных дистрибьюторов Европы, Америки и Азии.

С конца 2013 года компания активно расширяет линейку поставок компонентов по направлению коаксиальный кабель, кварцевые генераторы и конденсаторы (керамические, пленочные, электролитические), за счёт заключения дистрибьюторских договоров

Мы предлагаем:

- Конкурентоспособные цены и скидки постоянным клиентам.
- Специальные условия для постоянных клиентов.
- Подбор аналогов.
- Поставку компонентов в любых объемах, удовлетворяющих вашим потребностям.
- Приемлемые сроки поставки, возможна ускоренная поставка.
- Доставку товара в любую точку России и стран СНГ.
- Комплексную поставку.
- Работу по проектам и поставку образцов.
- Формирование склада под заказчика.
- Сертификаты соответствия на поставляемую продукцию (по желанию клиента).
- Тестирование поставляемой продукции.
- Поставку компонентов, требующих военную и космическую приемку.
- Входной контроль качества.
- Наличие сертификата ISO.

В составе нашей компании организован Конструкторский отдел, призванный помогать разработчикам, и инженерам.

Конструкторский отдел помогает осуществить:

- Регистрацию проекта у производителя компонентов.
- Техническую поддержку проекта.
- Защиту от снятия компонента с производства.
- Оценку стоимости проекта по компонентам.
- Изготовление тестовой платы монтаж и пусконаладочные работы.



Тел: +7 (812) 336 43 04 (многоканальный)
Email: org@lifeelectronics.ru