

# VSC7512

## 10-Port Layer-2 Gigabit Ethernet Switch

Microsemi's industrial Ethernet switch device delivers the industry's lowest power Gigabit Ethernet (GbE) switching solution.

The VSC7512 is a fully-integrated 10-port GbE switch with four copper PHYs in a single package.

The VSC7512 leverages Microsemi's SimpliPHY™ technology, resulting in the one of the most cost-effective and lowest power consumption devices in the industry. The single-chip solution utilizes the most advanced Energy Efficient Ethernet features for bringing low-power, high-performance solutions to market.

The VSC7512 provides a rich set of unmanaged Ethernet switching features such as Layer-2 forwarding with basic VLAN and QoS processing, enabling the delivery of differentiated services. The VSC7512 contains an 8051 CPU for configuration of the switch.

A comprehensive application software package is provided for LED control, loop indication, device overheat protection, and other enhanced functions.

### Highlights

- Low-power and single-chip industrial switch
- Four integrated copper PHY ports
- 2.5G SGMII NPI port or PCIe

### Applications

- Industrial Ethernet switches
- SME and SMB switches
- Customer-premise Equipment (CPE) and Network Termination Equipment (NTE)

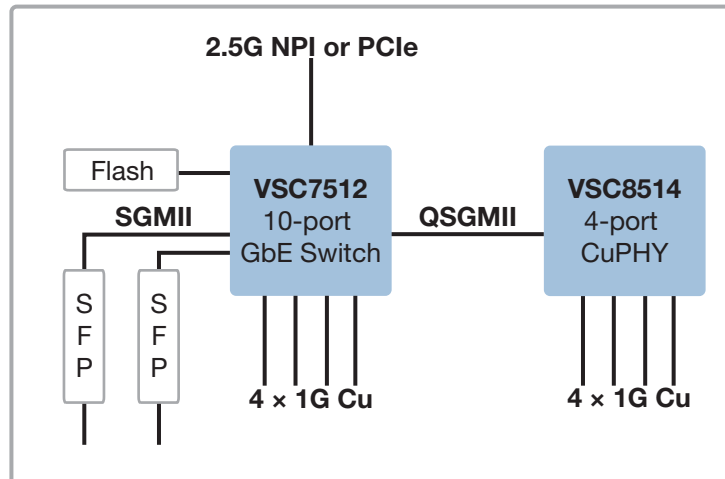

# VSC7512

## 10-Port Layer-2 Gigabit Ethernet Switch

### Best-In-Class Power Consumption

- Single IC reduces overall power requirements
- Optimal power consumption for all link speeds

### Features

- 4 integrated copper PHY ports
- 2 x 1G SGMII ports
- 2 x 2.5G SGMII ports (one port configurable as QSGMII)
- Integrated 250 MHz 8051 CPU with 64 KB internal storage
- PCIe and NPI for external CPU register access
- Device overheat protection
- Hardware loop detection
- Integrated fan controller
- 4K MAC addresses and 4K VLAN support

### Layer 2 Switching

- 10-port GbE switch with nonblocking wire-speed performance
- Link aggregation (IEEE 802.3ad) with programmable traffic distribution based on Layer 2 through Layer 4 information
- Wire-speed hardware-based learning and CPU-based learning configurable per port
- Independent and shared VLAN learning
- Jumbo frame support up to 12.2 KB with per-port programmable MTU
- Q-in-Q tagging support
- 1.75 Mb of integrated shared packet memory

### QoS

- Eight QoS queues per port with strict or deficit-weighted round robin scheduling
- QoS classification based on IEEE 802.1p and IPv4/IPv6 DSCP
- Data rate shaper and policer per-queue, per-port for both ingress and egress directions
- Full-duplex flow control (IEEE 802.3x) and half-duplex back-pressure, symmetric and asymmetric
- Multicast and broadcast storm control with flooding control

### Key Specifications

- 13 mm × 13 mm DRQFN package
- -40 °C to 125 °C temperature range

### Related Products

Visit [www.microsemi.com](http://www.microsemi.com) for information about these related products:

- Ethernet switches
- 1G copper PHYs

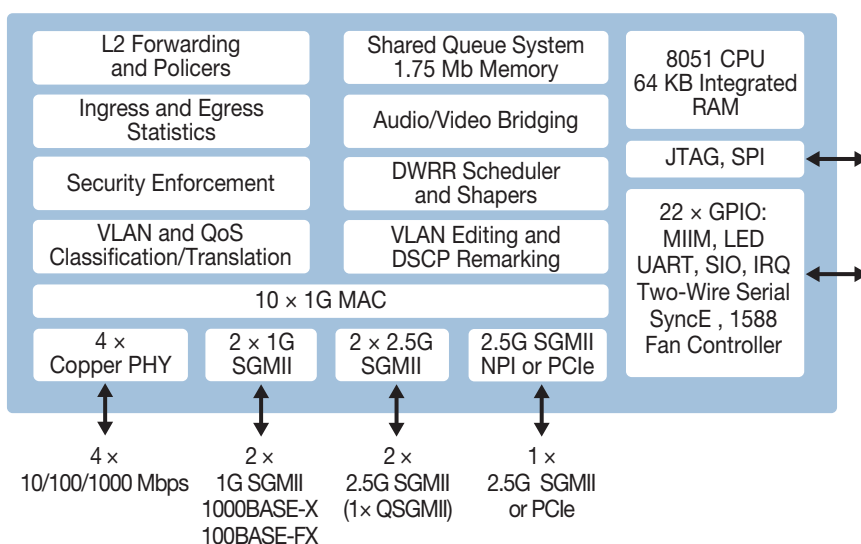

**Microsemi Corporate Headquarters**  
 One Enterprise, Aliso Viejo, CA 92656 USA  
 Within the USA: +1 (800) 713-4113  
 Outside the USA: +1 (949) 380-6100  
 Sales: +1 (949) 380-6136  
 Fax: +1 (949) 215-4996  
 email: [sales.support@microsemi.com](mailto:sales.support@microsemi.com)  
[www.microsemi.com](http://www.microsemi.com)

Microsemi Corporation (Nasdaq: MSCC) offers a comprehensive portfolio of semiconductor and system solutions for communications, defense & security, aerospace and industrial markets. Products include high-performance and radiation-hardened analog mixed-signal integrated circuits, FPGAs, SoCs and ASICs; power management products; timing and synchronization devices and precise time solutions, setting the world's standard for time; voice processing devices; RF solutions; discrete components; enterprise storage and communication solutions, security technologies and scalable anti-tamper products; Ethernet solutions; Power-over-Ethernet ICs and midspans; as well as custom design capabilities and services. Microsemi is headquartered in Aliso Viejo, Calif., and has approximately 4,800 employees globally. Learn more at [www.microsemi.com](http://www.microsemi.com).

Компания «Life Electronics» занимается поставками электронных компонентов импортного и отечественного производства от производителей и со складов крупных дистрибьюторов Европы, Америки и Азии.

С конца 2013 года компания активно расширяет линейку поставок компонентов по направлению коаксиальный кабель, кварцевые генераторы и конденсаторы (керамические, пленочные, электролитические), за счёт заключения дистрибьюторских договоров

Мы предлагаем:

- Конкурентоспособные цены и скидки постоянным клиентам.
- Специальные условия для постоянных клиентов.
- Подбор аналогов.
- Поставку компонентов в любых объемах, удовлетворяющих вашим потребностям.
- Приемлемые сроки поставки, возможна ускоренная поставка.
- Доставку товара в любую точку России и стран СНГ.
- Комплексную поставку.
- Работу по проектам и поставку образцов.
- Формирование склада под заказчика.
- Сертификаты соответствия на поставляемую продукцию (по желанию клиента).
- Тестирование поставляемой продукции.
- Поставку компонентов, требующих военную и космическую приемку.
- Входной контроль качества.
- Наличие сертификата ISO.

В составе нашей компании организован Конструкторский отдел, призванный помогать разработчикам, и инженерам.

Конструкторский отдел помогает осуществить:

- Регистрацию проекта у производителя компонентов.
- Техническую поддержку проекта.
- Защиту от снятия компонента с производства.
- Оценку стоимости проекта по компонентам.
- Изготовление тестовой платы монтаж и пусконаладочные работы.



Тел: +7 (812) 336 43 04 (многоканальный)

Email: [org@lifeelectronics.ru](mailto:org@lifeelectronics.ru)