

# VSC7414

## 11-Port Layer-2 SGMII Gigabit Ethernet Enterprise Switch with VeriTime™

Microsemi's newest member of the SparX-III switch family delivers a low-power solution for Enterprise routing, industrial switching solutions, and Audio Video Bridging (AVB).

VSC7414 contains nine 10/100/1000 Mbps SGMII/SerDes ports and two 1G/2.5G SGMII/SerDes ports. All ports support both 100BASE-FX and 1000BASE-X SerDes. VSC7414 provides a rich set of Ethernet switching features such as Layer-2 forwarding with advanced TCAM-based VLAN and QoS processing enabling delivery of differentiated services.

For critical network timing applications, VSC7414 uses VeriTime™, Microsemi's patent-pending distributed timing technology that delivers the industry's most accurate IEEE 1588v2 timing implementation.

Security is assured through frame processing using a TCAM-based Versatile Content Aware Processor (VCAP).

VSC7414 includes an embedded 416 MHz MIPS processor 32-bit CPU with DDR2/DDR3 external memory.

A comprehensive application programming interface (API) and software package are provided. The software package integrates easily with third-party software, preserving existing software investments while adding new, enhanced functionality.

### Highlights

- Best-in-class power and small footprint 11-port SGMII switch
- All ports provide direct connectivity to 1 Gbps and 100 Mbps optical modules supporting industrial temperature range
- Audio Video Bridging (AVB) with support for time-synchronized, low-latency audio video streaming services
- Priority-based, full-duplex flow control (IEEE 802.1Qbb)
- Integrated timing: VeriTime™, SyncE

### Applications

- Enterprise routing
- Industrial switching
- Audio Video Bridging (AVB)

**10-Port 1 GbE Switch Application**

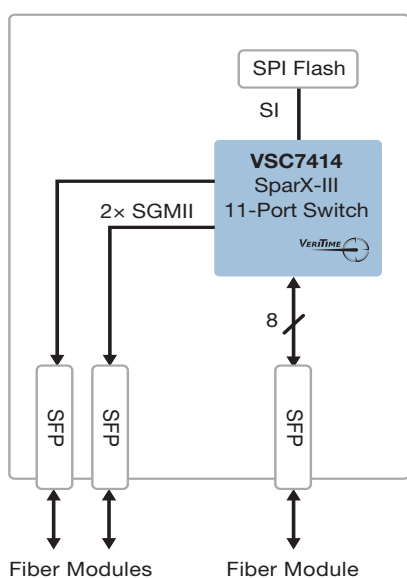

**9-Port 1 GbE UTM/Router Application**

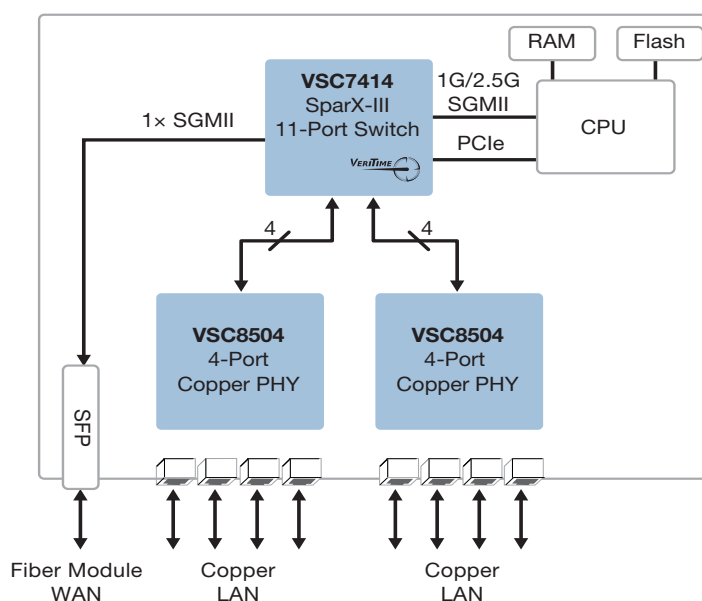

# VSC7414

## 11-Port Layer-2 SGMII Gigabit Ethernet Enterprise Switch with VeriTime™

### Layer 2 Switching

- IEEE 802.1Q VLAN switch with 8K MACs and 4K VLANs
- Exceptional low power consumption
- Fully nonblocking wire-speed switching performance for all frame sizes
- Push/pop up to two VLAN tags
- IPv4/IPv6 multicast
- RSTP and MSTP support
- Link aggregation (IEEE 802.3ad)
- Independent and shared VLAN learning (IVL, SVL)
- Jumbo frame support
- Wire-speed hardware-based learning and CPU-based learning configurable per port

### QoS Features

- Policing with storm control and MC/BC protection
- Advanced security and prioritization available through a multi-stage TCAM engine
- More than 8 QoS queues per port with strict or deficit-weighted round robin scheduling
- QoS classification based on IEEE 802.1p and IPv4/IPv6 DSCP
- Data rate shaper and policer per-queue, per-port for both ingress and egress directions
- Full-duplex flow control (IEEE 802.3x) and half-duplex back-pressure, symmetric and asymmetric

- Priority-based full-duplex flow control (IEEE 802.1Qbb)
- Dual leaky bucket policers with remarking
- L1 Synchronous Ethernet

### VeriTime™ Features

- L2 IEEE 1588v2
- Boundary clock and transparent clock

### Key Specifications

- 24 mm × 24 mm thermally enhanced TQFP package
- 1.6 W typical power dissipation
- Operating temperature –40 °C to 125 °C

### Related Products

Visit [www.microsemi.com](http://www.microsemi.com) for information about these related products:

- VSC7420-01 and VSC7424-01 10-Port Gigabit Ethernet Switches with Integrated Copper PHYs
- VSC7428-01 11-Port Layer 2 Gigabit Ethernet Switch with 8 Integrated Copper PHYs, Embedded CPU, and VeriTime™
- VSC8604 Quad-Port 10/100/1000BASE-T PHY with Synchronous Ethernet and QSGMII/SGMII MAC
- VSC8664 Quad Port 10/100/1000BASE-T PHY and 100BASE-FX/1000BASE-X SerDes with I2C Mux and Recovered Clock Outputs

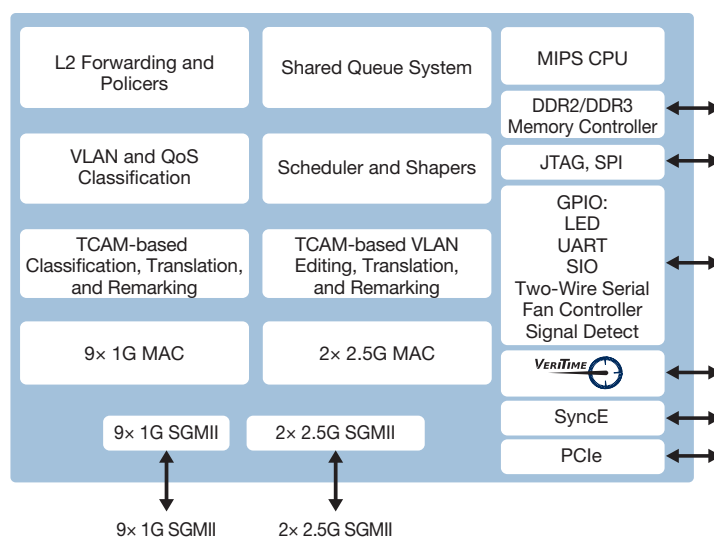

**Microsemi**

**Microsemi Corporate Headquarters**  
 One Enterprise, Aliso Viejo, CA 92656 USA  
 Within the USA: +1 (800) 713-4113  
 Outside the USA: +1 (949) 380-6100  
 Sales: +1 (949) 380-6136  
 Fax: +1 (949) 215-4996  
 email: [sales.support@microsemi.com](mailto:sales.support@microsemi.com)  
[www.microsemi.com](http://www.microsemi.com)

Microsemi Corporation (Nasdaq: MSCC) offers a comprehensive portfolio of semiconductor and system solutions for communications, defense and security, aerospace, and industrial markets. Products include high-performance and radiation-hardened analog mixed-signal integrated circuits, FPGAs, SoCs, and ASICs; power management products; timing and synchronization devices and precise time solutions; voice processing devices; RF solutions; discrete components; enterprise storage and communications solutions, security technologies, and scalable anti-tamper products; Ethernet solutions; Power-over-Ethernet ICs and midspans; custom design capabilities and services. Microsemi is headquartered in Aliso Viejo, California, and has approximately 4,800 employees worldwide. Learn more at [www.microsemi.com](http://www.microsemi.com).

Компания «Life Electronics» занимается поставками электронных компонентов импортного и отечественного производства от производителей и со складов крупных дистрибьюторов Европы, Америки и Азии.

С конца 2013 года компания активно расширяет линейку поставок компонентов по направлению коаксиальный кабель, кварцевые генераторы и конденсаторы (керамические, пленочные, электролитические), за счёт заключения дистрибьюторских договоров

Мы предлагаем:

- Конкурентоспособные цены и скидки постоянным клиентам.
- Специальные условия для постоянных клиентов.
- Подбор аналогов.
- Поставку компонентов в любых объемах, удовлетворяющих вашим потребностям.
- Приемлемые сроки поставки, возможна ускоренная поставка.
- Доставку товара в любую точку России и стран СНГ.
- Комплексную поставку.
- Работу по проектам и поставку образцов.
- Формирование склада под заказчика.
- Сертификаты соответствия на поставляемую продукцию (по желанию клиента).
- Тестирование поставляемой продукции.
- Поставку компонентов, требующих военную и космическую приемку.
- Входной контроль качества.
- Наличие сертификата ISO.

В составе нашей компании организован Конструкторский отдел, призванный помогать разработчикам, и инженерам.

Конструкторский отдел помогает осуществить:

- Регистрацию проекта у производителя компонентов.
- Техническую поддержку проекта.
- Защиту от снятия компонента с производства.
- Оценку стоимости проекта по компонентам.
- Изготовление тестовой платы монтаж и пусконаладочные работы.



Тел: +7 (812) 336 43 04 (многоканальный)

Email: [org@lifeelectronics.ru](mailto:org@lifeelectronics.ru)