

Accessories



Finger guards	242
Filter fan guards	250
Inlet rings	252
Connection cables / Accessories	255
Connection diagrams	258

ebm-papst offers a comprehensive selection of accessories for optimum fan operation, from temperature sensors for speed-controlled fans, to finger guards for all variants, to cables, filters, and screens, to spacers and installation parts. Even in the case of very special parts, you can be sure: We will assist you every way possible. The sales experts at ebm-papst will be happy to assist you with your question concerning fan installation and use.

From selection to accessories:

Insist on the efficient and reliable service provided by ebm-papst.

Finger guards

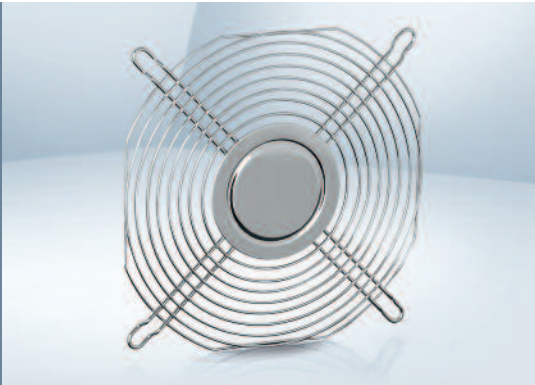

- **Material:** Galvanized or nickel-plated steel wire
 - **Note:** Finger guard according to DIN EN ISO 13857 (previously EN 294). Additional finger guards that do not satisfy DIN EN ISO 13857 available on request.
- Our finger guards are designed specifically to be used with ebm-papst fans. They combine the highest degree of safety with minimum effect on the operating noise. Please note that the safety-related clearances cannot be guaranteed when finger guards made by other manufacturers are used.

Fan series	Part no.
400	LZ29-1
420 J	LZ29-1
500	LZ31
600	LZ28-1
3000	LZ23-1
8000	LZ32-4 / LZ22-2
9000	LZ30-4 / LZ 30 / LZ 30-3
4000	LZ30-4 / LZ 30 / LZ 30-3

Fan series	Part no.
5100	LZ25
5600	LZ25
5200	LZ35
5300	LZ53
5900	LZ35
7000	LZ36
6300	LZ37
6400	LZ38

Fan series	Part no.	Side
2200 F	LZ22	
DV 4100	LZ30-4	Intake/outlet
DV 5200	LZ35	Intake/outlet
DV 6300 TD	LZ37	Intake side
DV 6300 TD	LZ52	Outlet side
DV 6400	LZ38	Intake side
DV 6400	LZ39	Outlet side

Subject to change

LZ29-1

Fan size 40 x 40

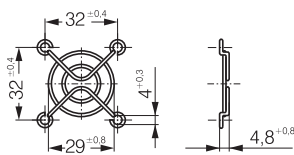

LZ31

Fan size 50 x 50

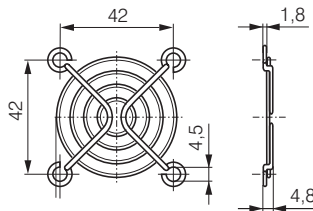

LZ28-1

Fan size 60 x 60

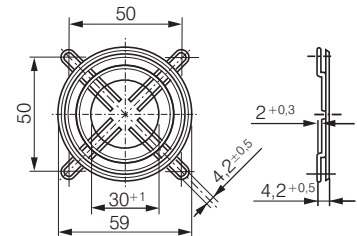

LZ22-2

Fan size 80 x 80

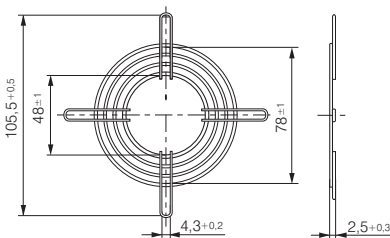

LZ32-4

Fan size 80 x 80

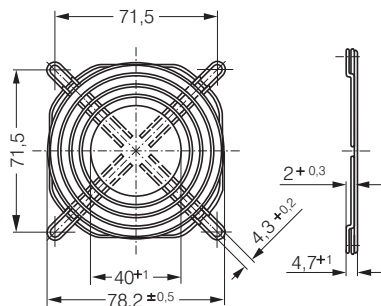

LZ23-1

Fan size 92 x 92

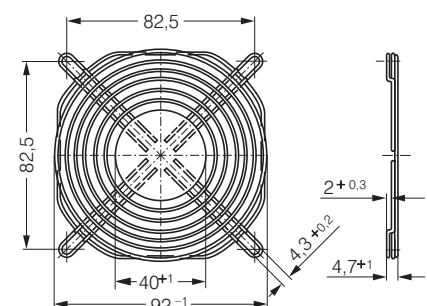

LZ30 Fan size 119 x 119

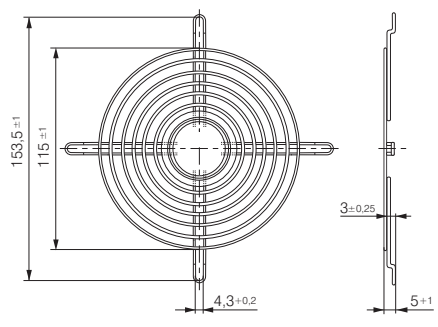

LZ30-3 Fan size 119 x 119

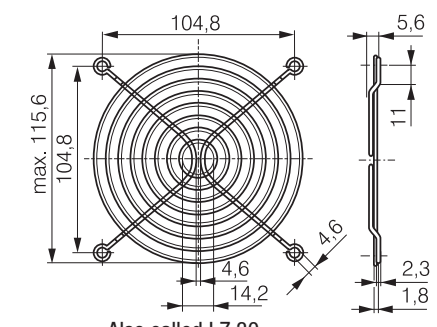

Also called LZ 30 for North America only.

LZ30-4 Fan size 119 x 119

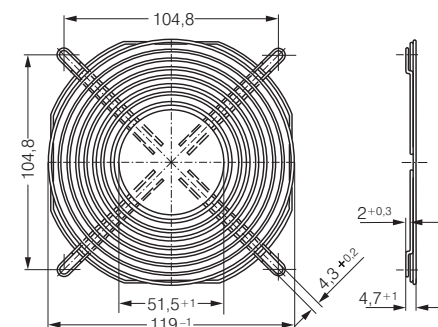

LZ35 Fan size 127 x 127

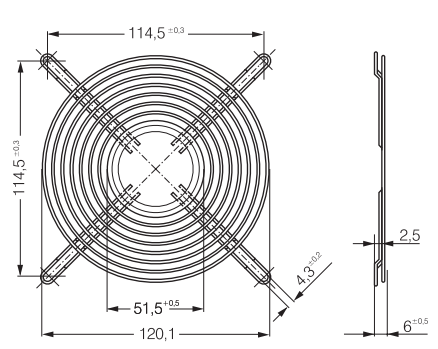

LZ25 Fan size 135 x 135

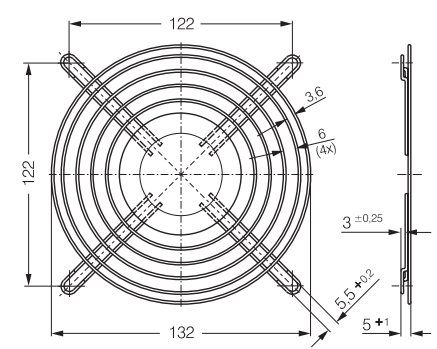

LZ53 Fan size 140 x 140

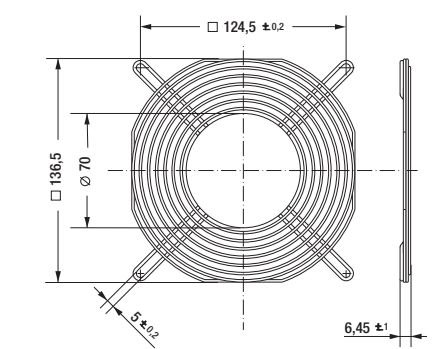

LZ36 Fan size 150 x 172

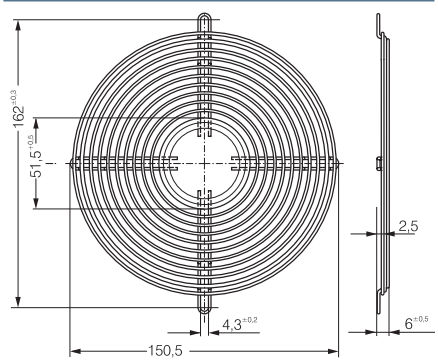

LZ37 Fan size 172 x 51

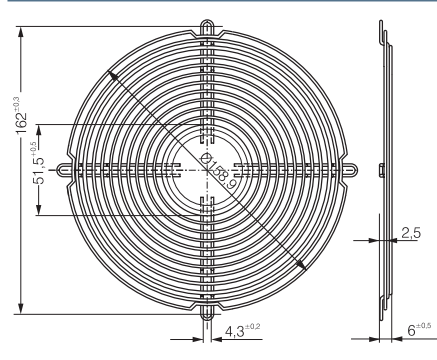

LZ38 Fan size 172 x 51

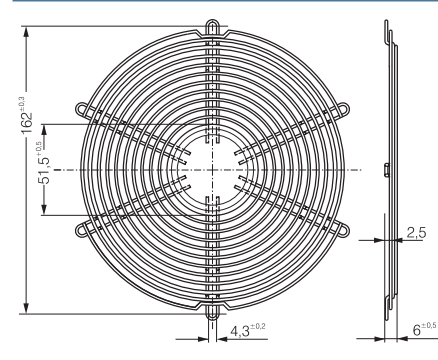

LZ39 Fan size 172 x 51

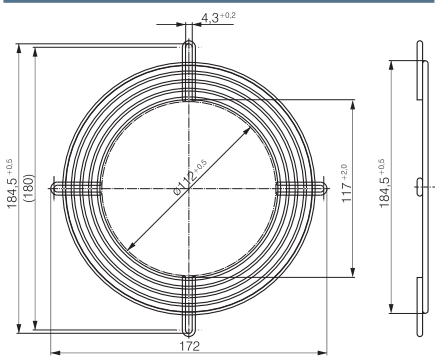

LZ52 Fan size 172 x 51

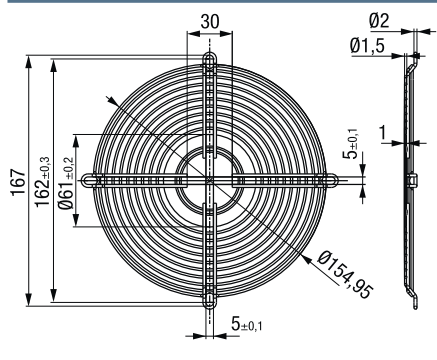

LZ22 Fan size 200 x 51

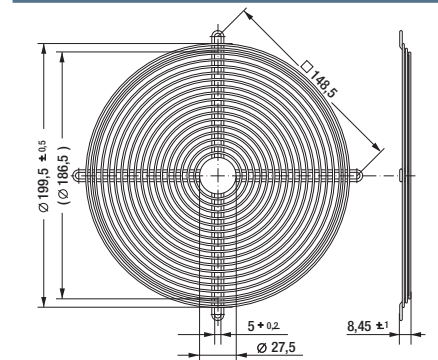

Finger guards

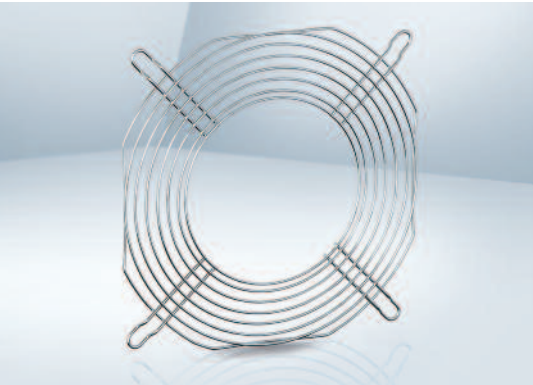

- **Material:** Galvanized or nickel-plated steel wire
- **Note:** Finger guard according to DIN EN ISO 13857 (previously EN 294).
The finger guard detailed on this page are intended specifically for the ACmaxx / GreenTech EC tubeaxial fan ranges and are mounted on the outlet side.

Fan series	Part no.	Side
AC 8300 H	LZ32-4	Intake
AC 8300 H	LZ32-7	Outlet
AC 3200 J	LZ23-1	Intake
AC 3200 J	LZ23-6	Outlet
AC 4400 FN	LZ30-4	Intake
AC 4400 FN	LZ30-9	Outlet
AC 4300	LZ30-4	Intake
AC 4300	LZ30-9	Outlet

Fan series	Part no.	Side
ACi 4400	LZ30	Intake
ACi 4400	LZ30	Outlet
AC 6200 N	LZ37	Intake
AC 6200 N	LZ37-2	Outlet

* Outlet-side guards on request

LZ30-9

Fan size 119 X 119

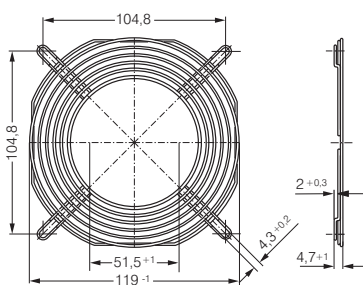

LZ37-2

Fan size Ø 172 X 51

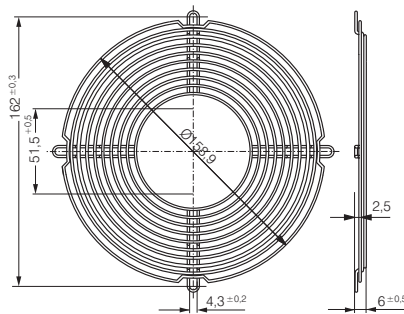

LZ23-6

Fan size 92 x 92

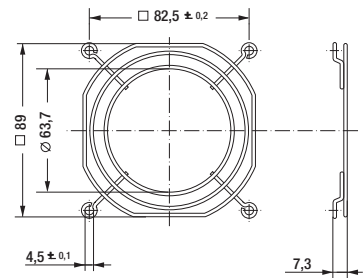

LZ32-7

Fan size 80 x 80

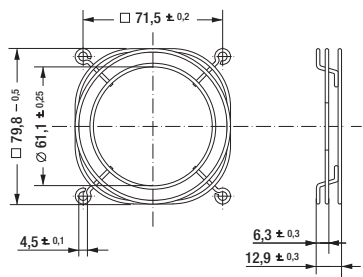

Finger guards

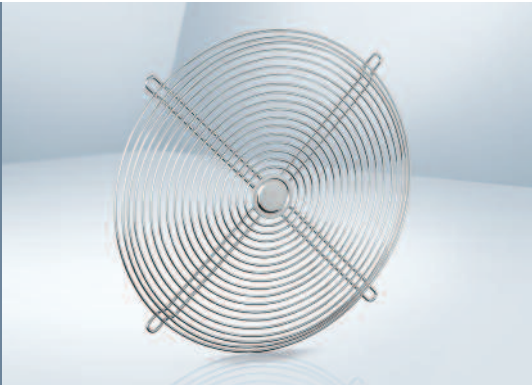

- **Material:** Steel wire, plastic-coated, with silver-metallic gloss

Fan series	Part no.
W3G 200	78128-2-4039

Fan series	Part no.
W1G 250	09418-2-4039
W3G 250	09418-2-4039

78128-2-4039

Fan size 200

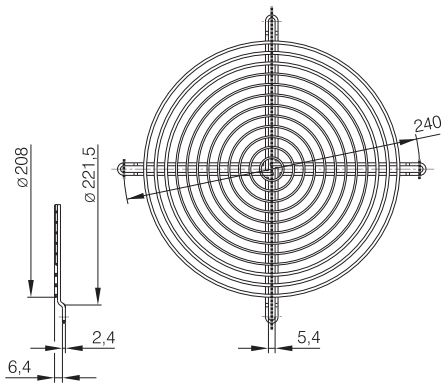

09418-2-4039

Fan size 250

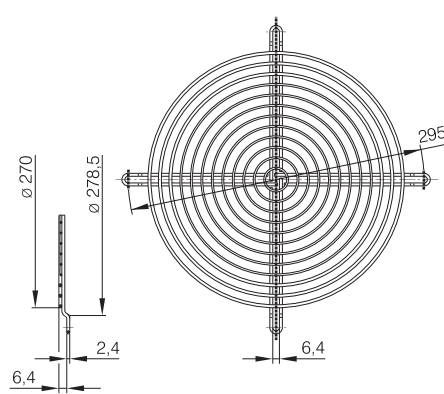

Finger guards

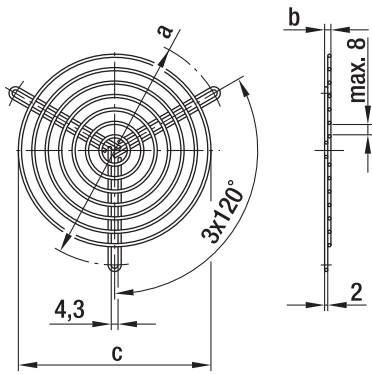

– **Material:** Steel wire

Finger guards for centrifugal blowers with dual inlet

Part no.	Fan size	a	b	c	Coating
83319-2-4039	097 ⁽¹⁾	96.0	3.5	71.0	Phosphated, plastic-coated in RAL no. 9005
09485-2-4039	097 ⁽²⁾	114.0	3.5	88.0	Phosphated, plastic-coated in RAL no. 9005
09500-2-4039	133 / 146	145.0	4.0	122.0	Phosphated, plastic-coated in RAL no. 9005

Subject to change

(1) for D2E097-CH

(2) for D2E097-B*

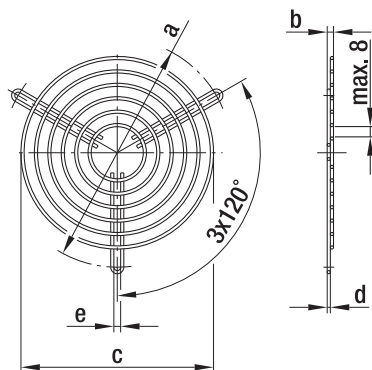

– **Material:** Phosphated steel wire, plastic-coated, silver-metallic gloss

Finger guards for centrifugal blowers with dual inlet (versions with EW motor)

Part no.	Fan size	a	b	c	d	e
35000-2-4039	160	182.0	12.0	144.0	2.4	4.5

Subject to change

Finger guards

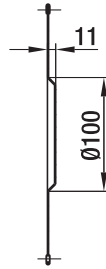
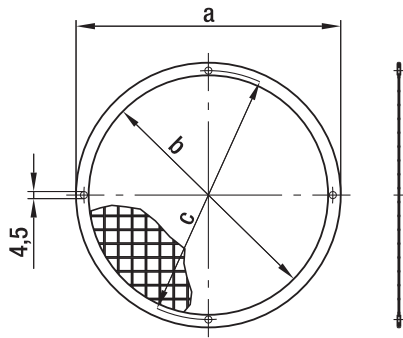

- **Material:** Welded screens made of hot-dip galvanized steel, border made of tin (0.4 mm thick)

⁽⁴⁾ Fan size 160

Finger guards for centrifugal blowers with single inlet

Part no.	Fan size	a	b	c
09489-2-4039	085 ⁽³⁾	90.0	74.0	84.0
09490-2-4039	108	126.0	110.0	118.0
09494-2-4039	120	140.0	124.0	132.0
09492-2-4039	140 / 146	168.0	152.0	158.0
09503-2-4039	160 ⁽⁴⁾	183.0	170.0	175.0

Subject to change

⁽³⁾ 3 drilled holes staggered by 120°

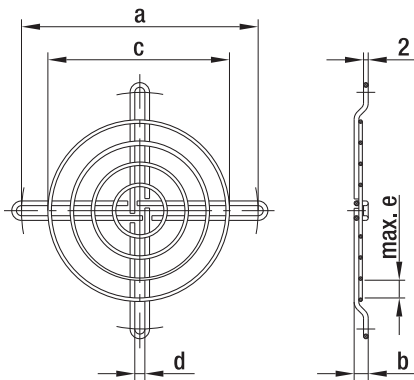

- **Material:** Steel wire

Finger guards for centrifugal blowers with single inlet

Part no.	Fan size	a	b	c	d	e	Coating
09603-2-4039	076 / 085	101.0	6.0	79.0	4.3	8.0	Plastic coated, silver-metallic gloss
98214-2-4039	108	120.0	3.5	88.0	4.3	8.0	Plastic coated, silver-metallic gloss
25028-2-4039	140 / 146	162.0	8.5	139.0	4.3	8.0	Galvanized, chromated in blue
17729-2-4039	160	175.0	3.5	139.0	4.6	7.0	Galvanized, chromated in blue

Subject to change

Finger guards



- **Material:** Fiberglass-reinforced plastic
- **Note:** Finger guard according to DIN EN ISO 13857 (previously EN 294). Plastic guards may not be used for the following models:
8200 JH3 / JH4
3200 JH3 / JH4
4100 NH5 - NH8

Part no.	Mounting	B	C	D	E	Part no.	Mounting	B	C	D	E
LZ28-3	A3	60 ^{-0.5}	50.0 ^{+0.2}	3.0	24	LZ30-5	A2	119 ^{-0.5}	105 ^{+0.2}	6.5	50
LZ32-2	A1	80 ^{-0.5}	71.5 ^{+0.2}	7.0	34	LZ30-6	A4	119 ^{-0.5}	105 ^{+0.2}	6.5	50
LZ32-3	A3	80 ^{-0.5}	71.5 ^{+0.2}	7.0	34	LZ33-1	A2	127 ^{-0.5}	113.5 ^{+0.2}	6.5	50
LZ23-2	A1	92.5 ^{-0.5}	82.5 ^{+0.2}	6.5	46	LZ33-2	A4	127 ^{-0.5}	113.5 ^{+0.2}	6.5	50
LZ23-3	A3	92.5 ^{-0.5}	82.5 ^{+0.2}	6.5	46	Subject to change					

LZ28-3	Fan size 60 x 60
LZ32-2 / LZ32-3	Fan size 80 x 80
LZ23-2 / LZ23-3	Fan size 92 x 92
LZ30-5 / LZ30-6	Fan size 119 x 119
LZ33-1 / LZ33-2	Fan size 127 x 127

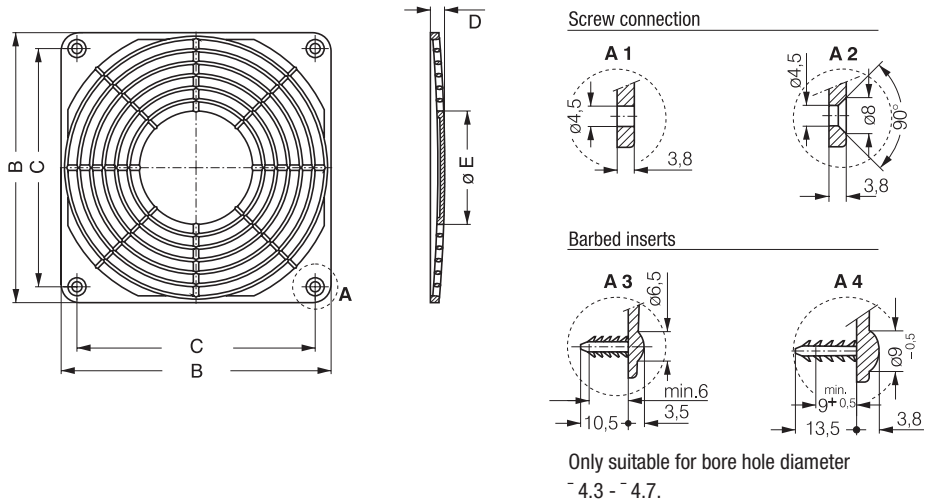

LZ28-3 Fan size 60 x 60

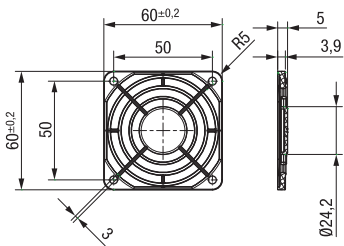

LZ32P Fan size 80 x 80

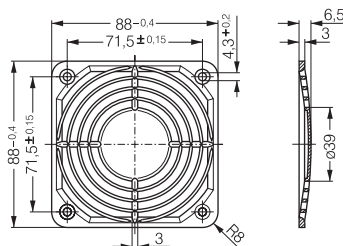

LZ30P Fan size 119 x 119

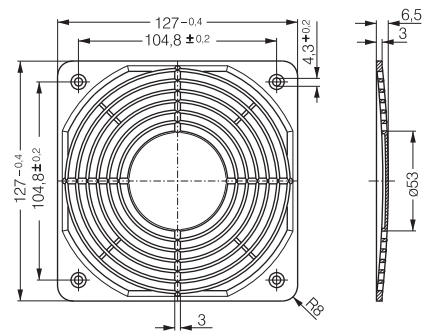

Finger guards

For compact centrifugal modules



- **Material:** PA plastic, fiberglass-reinforced
- **Highlights:** Flame protection class in line with UL 94V-0

Fan series	Part no.	a	b
RG 190	LZ46-1	133	9.0
RG 220	LZ47-1	166	8.7
RG 225	LZ48-1	158	8.7

Subject to change

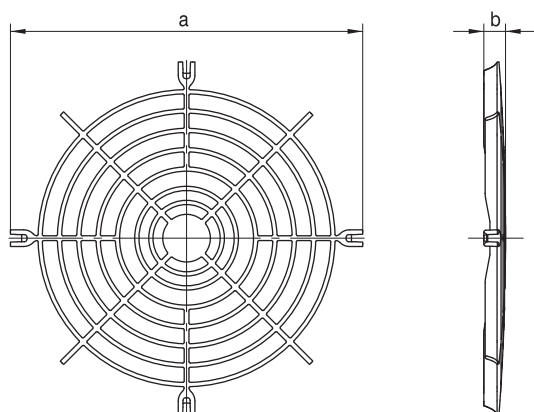

Filter fan guards

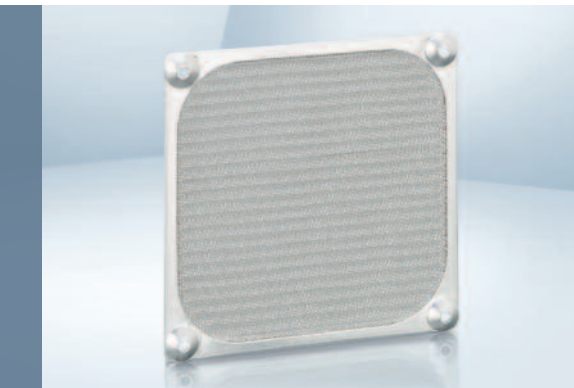

- **Material:** Filter guard LZ40 N: black, fiberglass-reinforced plastic with inserted wire mesh LZ60.
Coarse filter LZ60: stainless steel wire mesh
Mounting lug LZ40-1 for mounting

DC fan series	AC fan series
4400 F	AC 4300
4400 FN	9900
4300	4000 N
4400	4000 Z
4100 N	Subject to change

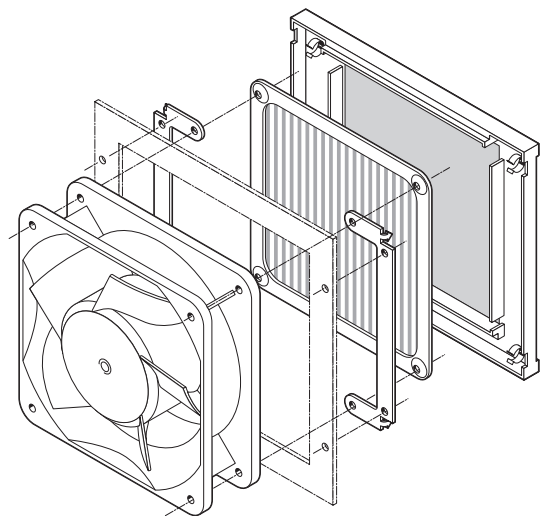

LZ40N

Filter guard

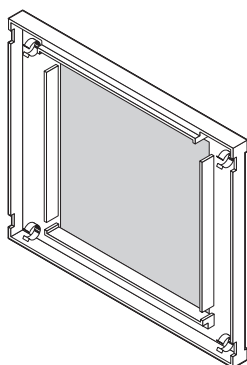

LZ40-1

Mounting lug

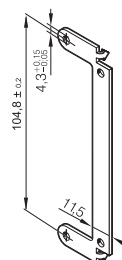
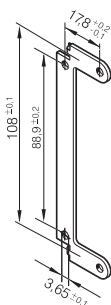

LZ60

Coarse filter

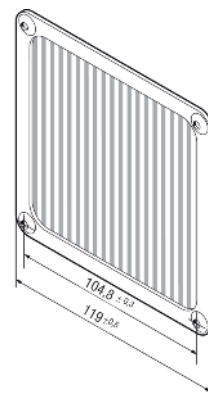

Filter fan guards



- **Material:** Guard cover: Injection-molded polycarbonate (PC) with mat surface.
Mounting plate: wire mesh with black powder coating
Filter pad: white, synthetically bonded fibers
- **Note:**
Filter fan guards suitable for fitting on axial fan series in sizes: 60 mm, 80 mm, 92 mm, 119 mm, \varnothing 172 mm. All filter units fit directly on the existing mounting holes of the fans.
Filter fan guards consisting of 3 parts: external guard cover, internal mounting plate, and replaceable filter pad.
The filter pad can be replaced quickly and easily via a quick release on the guard cover.
The filter pads can be replaced even while the fan is running, as protection is provided by the welded wire mesh.

Part no.	Fan size	A	B	C	D	Part no. Replacement filter*
FF60	60 x 60 mm	65	65	13.5	50.0	RF 60
FF80	80 x 80 mm	85	85	14.0	71.5	RF 80
FF92	92 x 92 mm	125	105	17.5	82.5	RF 92
FF119	119 x 119 mm	162	136	18.5	104.5	RF 119
FF172	\varnothing 172 mm	226	190	19.5	162.0	RF 172

Subject to change

* Replacement filter available only in packages of 5.

FF60 / FF80

Fan size: 60 x 60 mm
80 x 80 mm

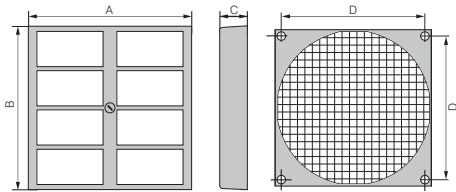

FF92 / FF 119

Fan size: 92 x 92 mm
119 x 119 mm

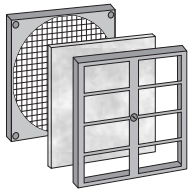
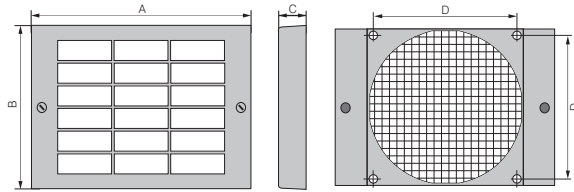

FF 172

Fan size: \varnothing 172 mm

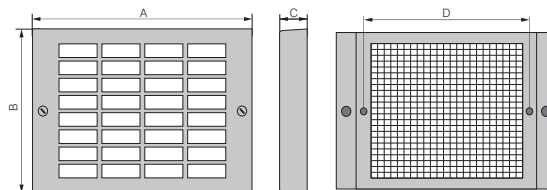

Filter performance

The filter fan guard filters 75% of dust particles with a size of 5-10 microns and can withstand temperatures of up to 100 °C. Filter class G3 according to DIN EN 779. Flame-retardant according to DIN 53438, class F1. When a clean filter is installed, a reduction of air flow of 20-30% is possible.

Inlet rings

For centrifugal fans

– **Material:** Galvanized sheet steel

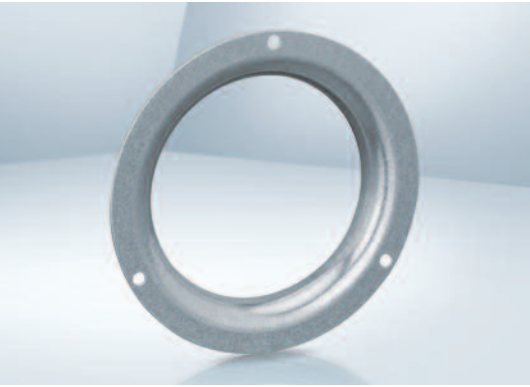

Fan	Part no.	k	m	o	q	r ₁	s	t	u	Vers.
RET 97	(S) LZ 1000-097	116,0	80,0	10,0	0,80	10,0	108,0	3x4,5	–	1
RER 120	(K) LZ 1000-120	146,0	94,4	18,0	0,80	16,0	134,0	4x4,5	126,0	1
RER 133	(K) LZ 1000-133	129,0	87,0	13,0	1,00	8,0	118,0	4x4,5	103,0	1
RER 160	(S) LZ 1000-160	142,0	100,0	9,0	1,00	8,0	132,0	4x4,5	–	1
RER 175 / 190	(K) LZ 1000-175	170,0	125,5	14,0	1,25	10,0	158,0	4x4,5	146,0	1
RER 220	(K) LZ 1000-220	252,0	155,0	21,0	0,80	22,0	–	–	199,0	2
RER 225	(K) LZ 1000-225	223,0	146,0	28,0	1,50	25,0	210,0	4x4,5	196,0	1

(P) = plastic, (S) = galvanized sheet steel

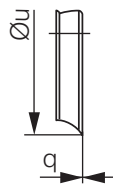
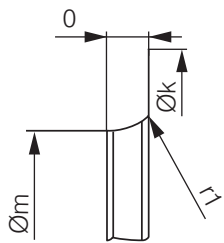

Vers. 1

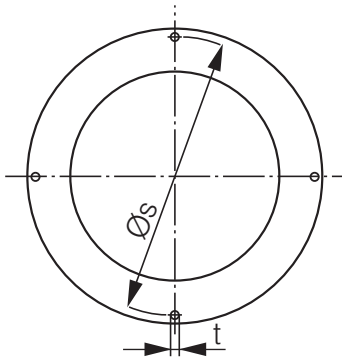

Vers. 2

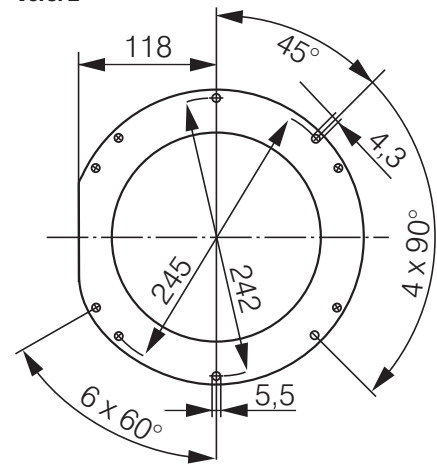

Inlet rings

For centrifugal fans

– **Material:** Galvanized sheet steel

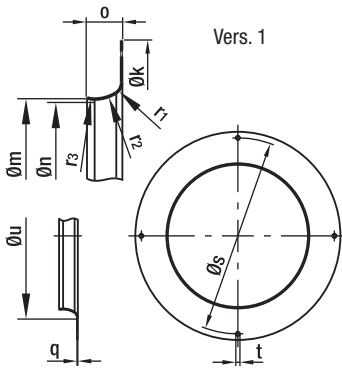

Inlet rings for backward curved centrifugal fans

Part no.	Fan size ⁽¹⁾	Vers.	k	m	n	o	q	r ₁	r ₂	r ₃	s	t	u
96120-2-4013	120 (P)	1	146.0	94.4	—	18.0	0.80	16.0	—	—	134.0	4x4.5	126.0

Subject to change (1) Fan size with key for impeller material: (P) = plastic, (S) = sheet steel, (A) = aluminum

Vers. 1

– **Material:** Galvanized sheet steel

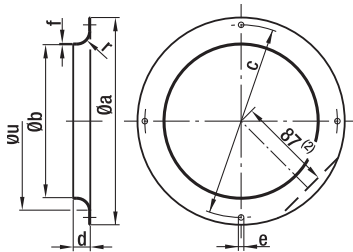

Inlet rings for forward curved centrifugal fans

Part no.	Fan size	Vers.	a	b	c	d	e	f	r	u
09560-2-4013	085 ⁽¹⁾	1	92.0	63.4	84.0	6.0	3x4.2	0.80	6.8	—
09563-2-4013	097 ⁽¹⁾	1	116.0	80.0	108.0	10.0	3x4.5	0.80	10.0	—
09566-2-4013	108	1	129.0	87.0	118.0	13.0	4x4.5	1.00	8.0	—
09569-2-4013	120	1	142.0	100.0	132.0	9.0	4x4.5	1.00	8.0	—
09572-2-4013	133	1	150.0	112.0	142.0	12.0	4x4.5	1.00	10.0	—
09576-2-4013	140 / 146	1	170.0	125.5	158.0	14.0	4x4.5	1.25	10.0	—
09588-2-4013	160	1 ⁽²⁾	185.0	130.0	175.0	17.0	4x4.5	0.75	12.0	—

Subject to change (1) 3 drilled holes staggered by 120° (2) only for 09588-2-4013

Inlet rings / air filter

For centrifugal fans

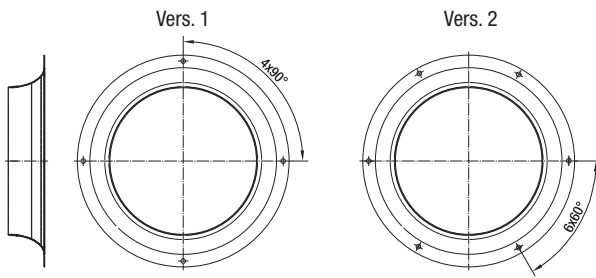

Material: Galvanized sheet steel

Inlet rings without measuring device for backward curved centrifugal fans

Part no.	Fan size	Vers.	Dimensions
09576-2-4013	190	1	See corresponding product page
09609-2-4013	220	2	See corresponding product page
96358-2-4013	225	1	See corresponding product page
96359-2-4013	250	1	See corresponding product page
28000-2-4013	280	1	See corresponding product page
31000-2-4013	310	1	See corresponding product page

Subject to change

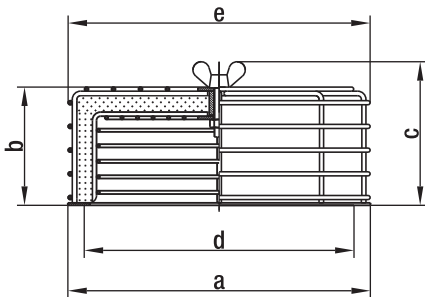

- **Material:** Steel wire or sheet steel, plastic coated in RAL no. 9005, black
- **Filter:** Viledon filter type R: PSB / 29 OS (according to DIN 24185)
Separation capacity: < 86%
Efficiency: < 20%
Dust binding capacity: 650 g/m²

Air filters for centrifugal blowers (with die-cast aluminum housing)

Part no.	Fan size	a	b	c	d	e	Replacement filter
95777-1-5171	108 / 120	142.0	66.0	83.0	118-132	145.0	95779-1-5171
95778-1-5171	140 / 146 / 160	185.0	74.0	91.0	158-175	185.0	95780-1-5171

Subject to change

Cables

- Cable with molded plug connection in varying lengths.
- Wire end with wire end ferrules, crimped ferrules, or tin-plated.
- Straight or angled plug.
- For all fan types with flat plug 2.8 / 3.0 x 0.5.



Part no.	L1 (mm)	Wires	Plug	Wire end	Flat push-on receptacle	Application
LZ120	610	0.5 mm ²	G	C	2.8 x 0.5	AC
LZ120-4	2 000	0.5 mm ²	G	A	2.8 x 0.5	AC
LZ120-5	380	0.5 mm ²	W	B	2.8 x 0.5	DC
LZ120-6	610	0.5 mm ²	W	B	2.8 x 0.5	DC
LZ120-11	2 000	0.5 mm ²	G	A	2.8 x 0.5	DC
LZ120-16	800	0.5 mm ²	G	B	2.8 x 0.5	AC
LZ120-18	4 000	0.5 mm ²	G	A	2.8 x 0.5	AC
LZ126	1 000	0.5 mm ²	G	C	2.8 x 0.5	AC
LZ127	1 600	0.5 mm ²	G	B	2.8 x 0.5	AC
LZ130-1	610	0.82 mm ²	G	C	2.8 x 0.5	AC *
LZ140	610	0.73 mm ²	G	B	2.8 x 0.8	AC

* UL-approved

Cable Straight plug (G)

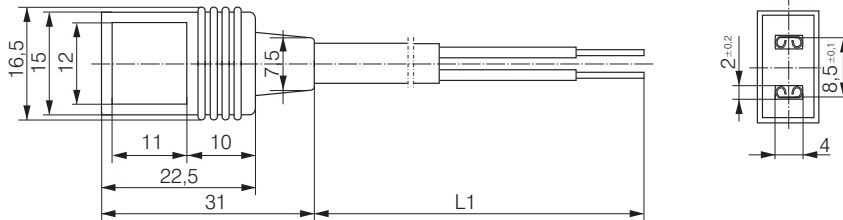

Cable Angled plug (W)

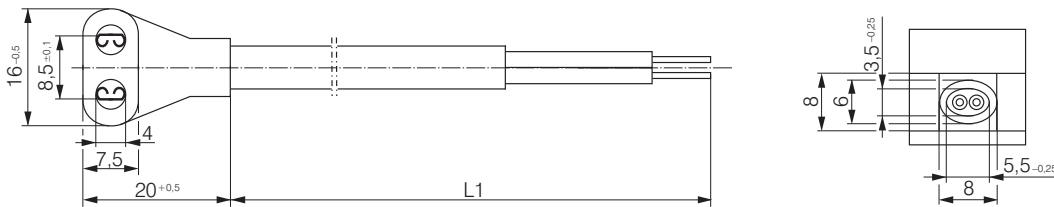

Wire end ferrules

Wire end A

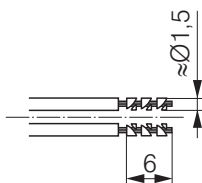

Tin-plated

Wire end B

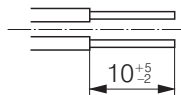

Wire end ferrules

Wire end C

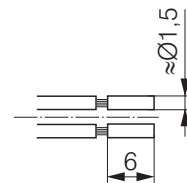

Cable (ESM) / Handheld Programmer

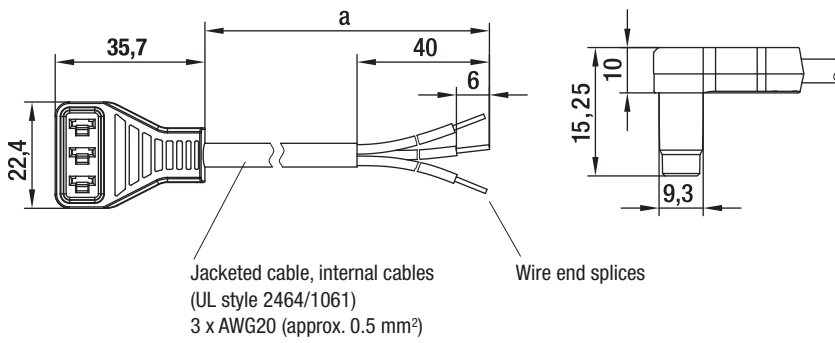

- **Design:** Cable conforms to UL standards sealed plug. Customized cables on request.

Cables for energy-saving motors 115/230 VAC

Part no.	a
13060-4-1040	450
13061-4-1040	1500

Subject to change



- Easy speed programming
- Battery operated
- User-friendly navigation menu
- Protective cover with folding stand

For Energy Saving Motor (ESM) based products

Part no.

CBC 000-AF08-01

Subject to change

Makes quick work of programming the two ESM adjustable operating speeds. Eliminates the need for a PC, software adapter and second cable. Especially for use in production or by sales representatives. Automatic shut-off function for extended battery life. Mini USB plug for downloading software updates. Batteries, programming cable, and operating instructions included in scope of delivery.

Accessories

In addition to the accessories and installation parts listed here, ebm-papst also supplies a number of additional, sometimes very special parts for fans. Our company sales team is happy to offer you their expert assistance with all your questions regarding the installation and use of our fans.

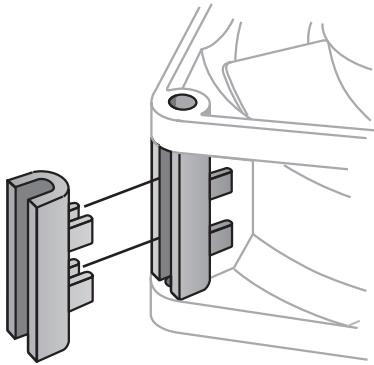

Fan series	Part no.
8300	LZ212 / LZ260
8400 N	LZ261
3400 N	LZ261
9000	LZ210
4000	LZ210
4300	LZ212 / LZ260

Fan series	Part no.
5100	LZ210
5600	LZ210
5200	LZ210
5900	LZ210
7000	LZ210
VARIOFAN	LZ370

LZ212

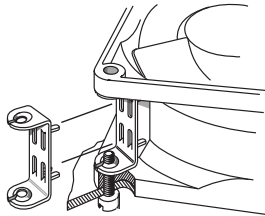

Screw clip of rustproof spring steel. For mounting fans with threaded pin 3.5 DIN EN ISO 1478 (7970).

LZ260/LZ261

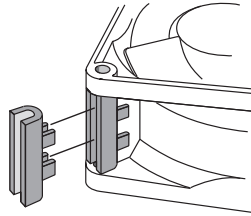

Spacer of fiberglass-reinforced plastic. For mounting with screws through both fan mounting flanges.

LZ210



Screw clip of hardened steel. For mounting fans with threaded pin 6-32 UNC or 3.5 DIN 7970.

LZ370

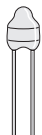

Required performance data:

R_{25}	= 100 K Ω \pm 5% @25°C
B-value	= 4190 \pm 2%
P_{max}	= 0,25 W

Temperature sensor for speed-controlled fan operation. Temperature range 30...50 °C.

LZ550

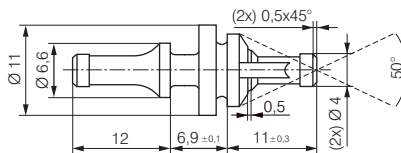

Rubber anti-vibration mounts for fans with a hole ϕ of 4.3 ± 0.2 mm and flange thickness of 3 to 5.5 mm. For a carrier plate with a hole ϕ of 6.5 ± 0.15 mm and plate thickness of 1 to 2 mm.

Connection diagrams EC E)

Technical features (nominal voltage 24 / 48 VDC):

- Control input 0-10 VDC / PWM
- Tach output
- Reverse polarity and locked-rotor protection
- Motor current limitation
- Voltage-dependent derating
- Thermal overload protection electronics
- Soft startup

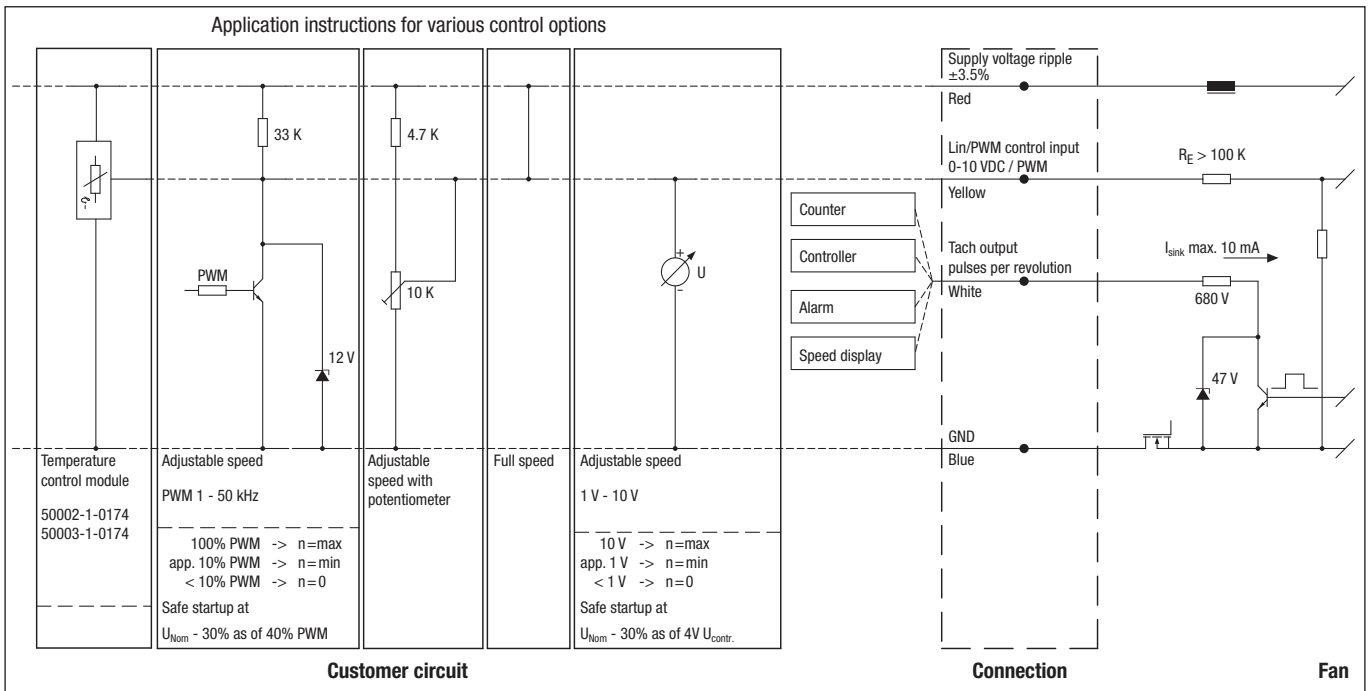

Wire 1

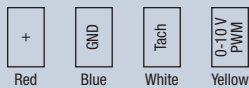

Connection diagrams EC

G)

Technical features (nominal voltage 24 / 48 VDC):

- Control input 0-10 VDC / PWM
- Tach output
- Reverse polarity and locked-rotor protection

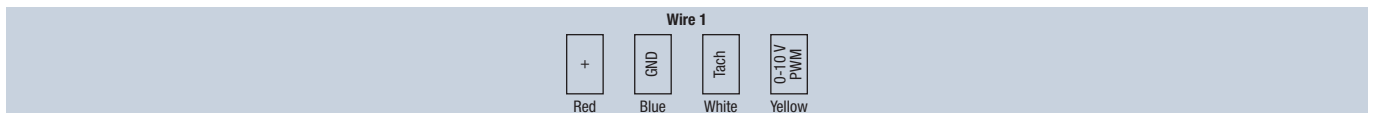
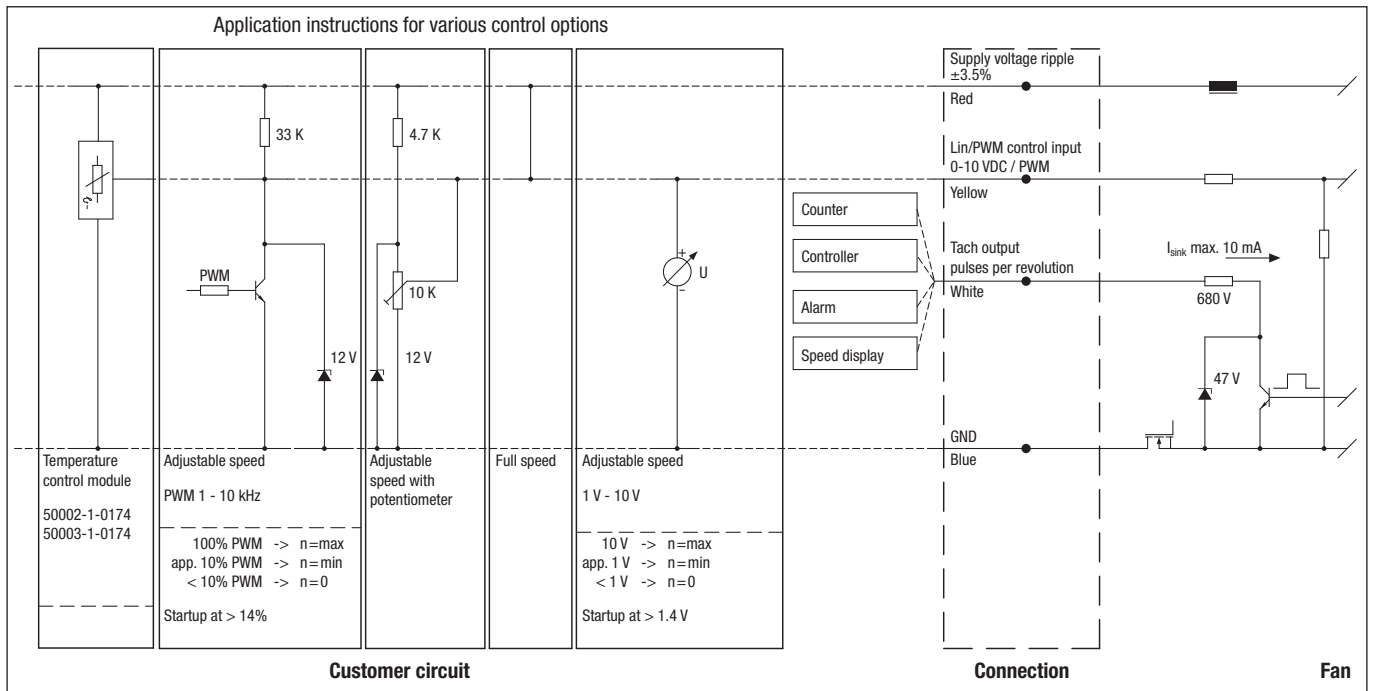

Wire	Connection	Color	Assignment/function
1	+	Red	Supply voltage ripple $\pm 3.5\%$
	GND	Blue	GND

Wire	Connection	Color	Assignment/function
1	Tach	White	Tach output: 2 pulses/revolution (M1G045/M1G055) 3 pulses/revolution (M1G074/M1G084)
	0-10 V / PWM	Yellow	Control input (impedance 100 kV)

Connection diagrams EC H3)

Technical features (M3G 055 with 2 speed stages):

- Speed setting input (230V)
- Thermal overload protection electronics / motor
- Motor current limitation
- Locked-rotor protection
- Soft startup

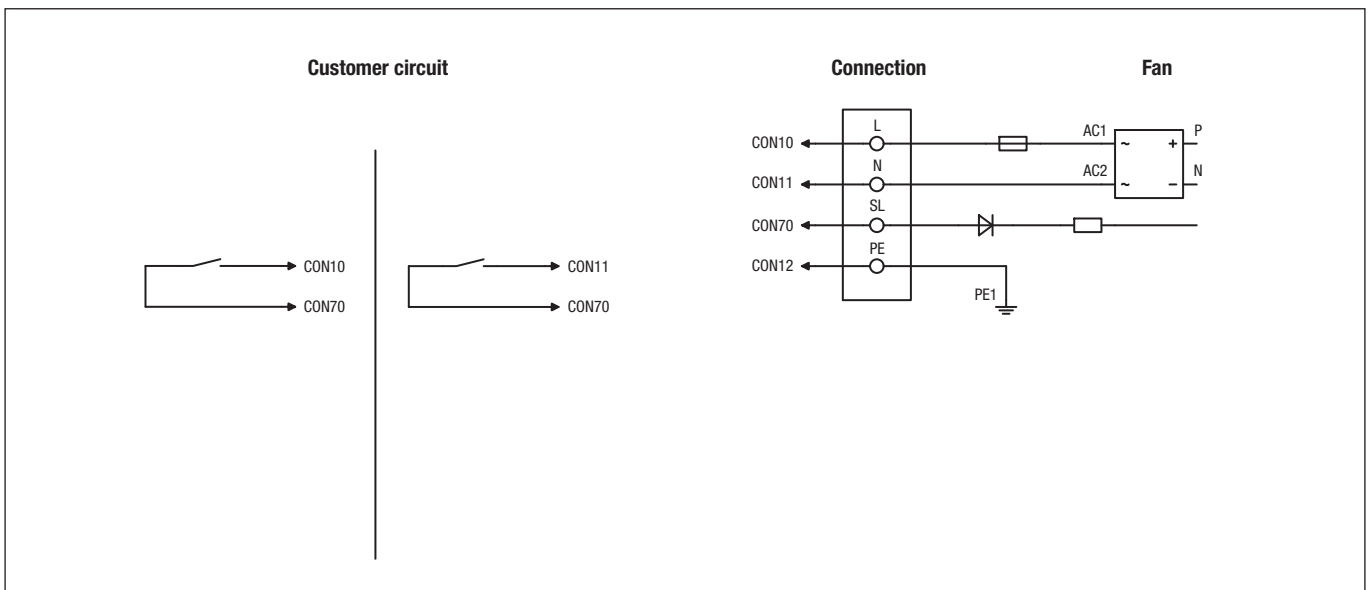

Wire	Connection	Color	Function / assignment
CON10	L	Black	Power supply 230 VAC, 50 - 60 Hz, see type plate for voltage range
CON11	N	Blue	Neutral conductor
CON12	PE	Green/yellow	Ground conductor
CON70	SL	brown	Speed selection: switch open = speed 1; switch closed = speed 2

Connection diagrams EC H4)

Technical features (M3G 055 speed-controlled):

- Output 10 VDC Max. 1.1 mA
- Tach output
- Thermal overload protection electronics / motor
- Motor current limitation
- Soft startup
- Locked-rotor protection
- Control input 0-10 VDC / PWM
- Control interface with SELV potential safely disconnected from the mains

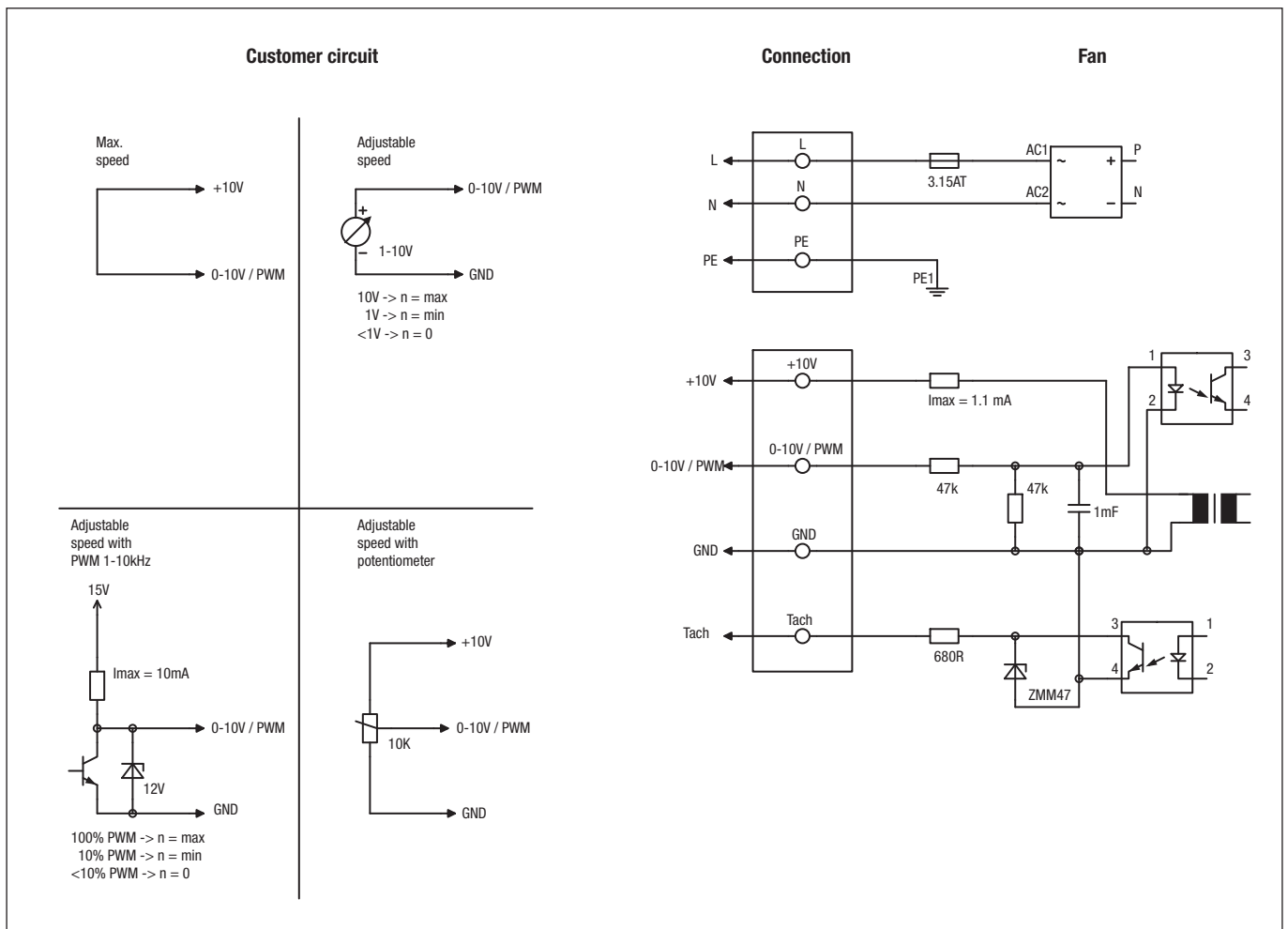

Connection	Color	Function / assignment
L	Black	Power supply 115/230 VAC, 50 - 60 Hz, see type plate for voltage range
N	Blue	Neutral conductor
PE	Green/yellow	Ground conductor
+10V/max.1.1mA	Red	Voltage output +10 V / 1.1 mA, electrically isolated, not short-circuit-proof
Tach	White	Tach output: Open collector, 1 pulse per revolution, electrically isolated
0-10V / PWM	Yellow	Control input 0-10 V or PWM, electrically isolated
GND	Blue	GND - Connection for control interface

Connection diagrams EC J5)

Technical features (nominal voltage 24 / 48 VDC):

- Control input 0-10 VDC / PWM
- Tach output
- Reverse polarity and locked-rotor protection
- Motor current limitation
- Line undervoltage detection
- Soft startup

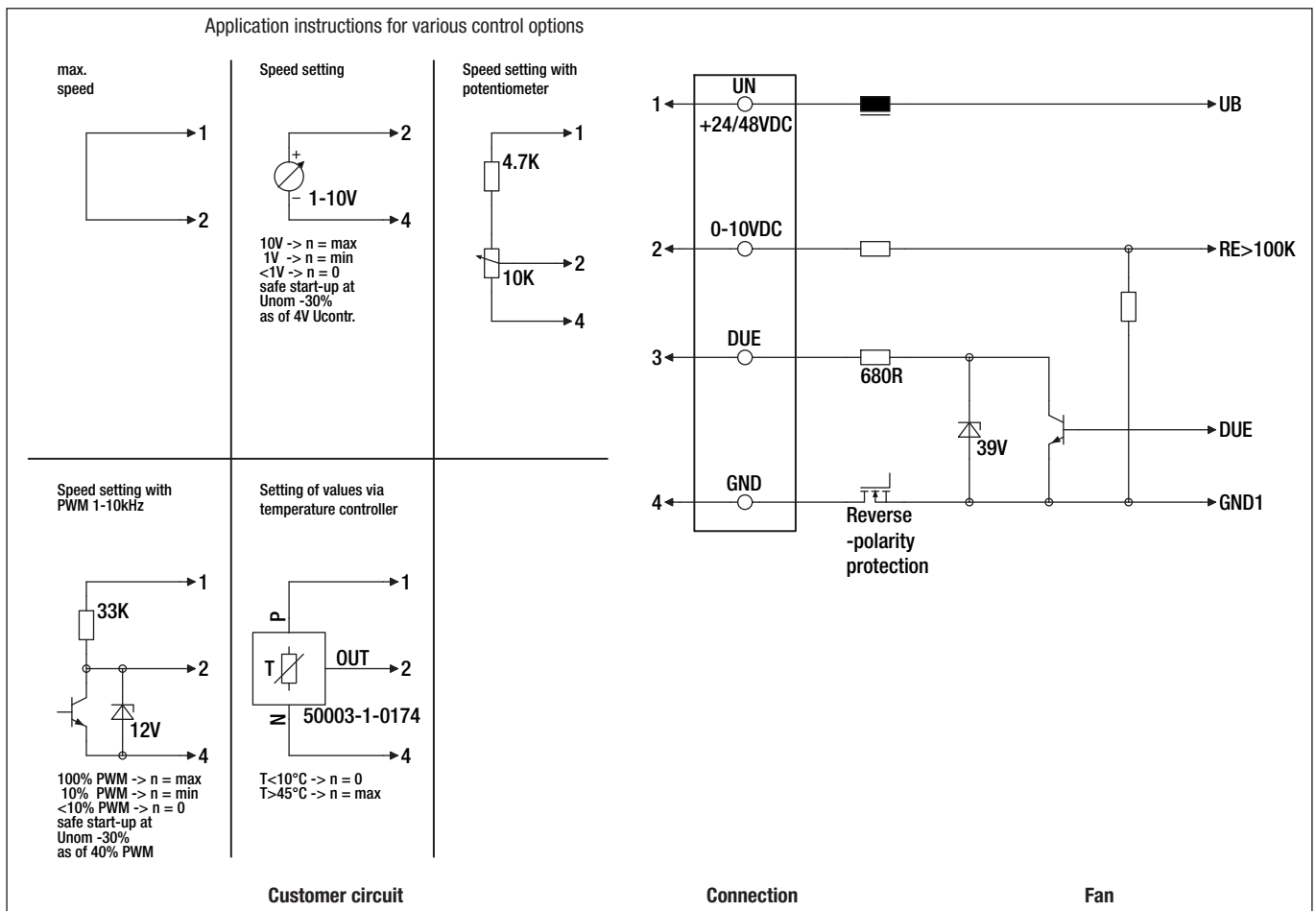

Wire	Connection	Color	Assignment/function
1	UN +24/48 VDC	Red	Power supply 24/48 VDC, supply voltage ripple $\pm 3.5\%$
2	0-10 VDC	Yellow	Control input Re >100 K
3	Tach	White	Tach output, 3 pulses per revolution, Isink max. = 10 mA
4	GND	Blue	Reference ground

Connection diagrams AC A1) / A3) / C2)

A1) Single-phase capacitor motor (1~ 115/230 VAC power line) with thermal overload protector wired internally

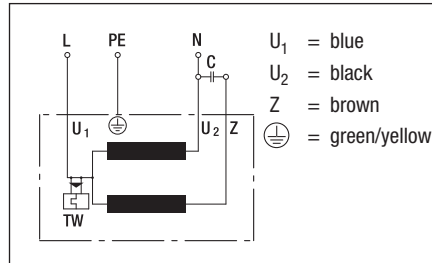

A3) Single-phase capacitor motor (1~ 115/230 VAC power line) with thermal overload protector wired internally

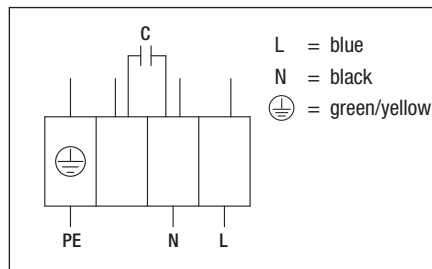

C2) Star connection (3~ 400 VAC power line) without thermal overload protector

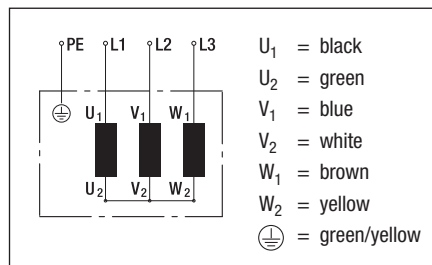

Connection diagrams AC J7)

J7) Energy-saving motor (ESM) (1~ 115/230 VAC power line)

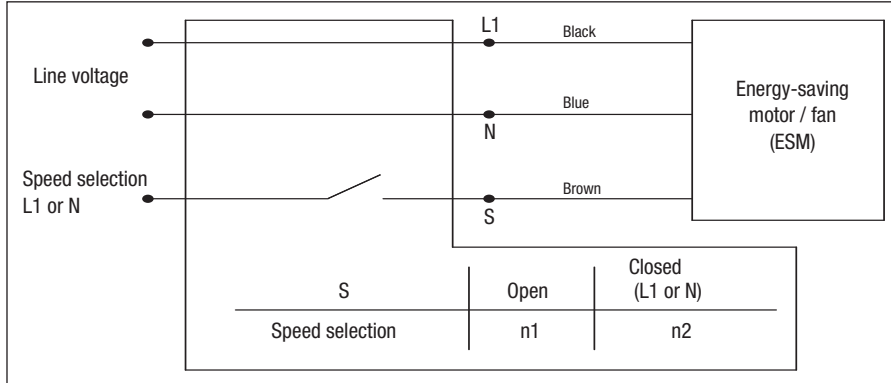

Компания «Life Electronics» занимается поставками электронных компонентов импортного и отечественного производства от производителей и со складов крупных дистрибьюторов Европы, Америки и Азии.

С конца 2013 года компания активно расширяет линейку поставок компонентов по направлению коаксиальный кабель, кварцевые генераторы и конденсаторы (керамические, пленочные, электролитические), за счёт заключения дистрибьюторских договоров

Мы предлагаем:

- Конкурентоспособные цены и скидки постоянным клиентам.
- Специальные условия для постоянных клиентов.
- Подбор аналогов.
- Поставку компонентов в любых объемах, удовлетворяющих вашим потребностям.
- Приемлемые сроки поставки, возможна ускоренная поставка.
- Доставку товара в любую точку России и стран СНГ.
- Комплексную поставку.
- Работу по проектам и поставку образцов.
- Формирование склада под заказчика.
- Сертификаты соответствия на поставляемую продукцию (по желанию клиента).
- Тестирование поставляемой продукции.
- Поставку компонентов, требующих военную и космическую приемку.
- Входной контроль качества.
- Наличие сертификата ISO.

В составе нашей компании организован Конструкторский отдел, призванный помогать разработчикам, и инженерам.

Конструкторский отдел помогает осуществить:

- Регистрацию проекта у производителя компонентов.
- Техническую поддержку проекта.
- Защиту от снятия компонента с производства.
- Оценку стоимости проекта по компонентам.
- Изготовление тестовой платы монтаж и пусконаладочные работы.



Тел: +7 (812) 336 43 04 (многоканальный)

Email: org@lifeelectronics.ru