



Optical Industrial Cable Assemblies and Adapters

106059 LC Duplex

106059 SC Simplex

106059 MPO Multi-fiber

Easy optical connections are now possible in harsh industrial environments with Molex's optical industrial cable assemblies

Designed with rugged and compact housings, Molex's optical industrial assemblies incorporate the high-performance of a fiber optic connection with the versatility of a rugged industrial connector. The assemblies guarantee an environmentally sealed optical connection in one step, with the combined push-pull insertion and bayonet-style mechanical latch. The bulkhead adapter mounts directly in a panel cut-out, serving as a sealed feed-through. The removable connector provides sealing between both the adapter mating-surface, as well as the cable exiting the connector.

Molex's optical industrial assemblies are compatible with many fiber types and cable constructions and are ideal for both indoor and outdoor applications. This assembly is particularly well-suited for long distances or remote connections using either single mode or multimode fiber.

Available in a simplex SC, Duplex LC, and multi-fiber MPO version, these assemblies offer a sealed fiber optic connection to fit many applications from bi-directional single fiber up to 12 fiber ribbon connections. Assemblies are available in pigtailed (single-ended), jumpers (dual-ended) and breakout assemblies, to any Molex standard fiber optic connector. The assemblies can be manufactured in lengths from 1.0 meter to well over 1.0 kilometer.

The industrial duplex LC assembly has been ratified as a 'Standard Interface' in the ODVA (Open DeviceNet Vendors Association) as a next generation industrial interconnect.



(Left to right) Industrial MPO, Industrial SC, Industrial LC Cable Assemblies

Features and Benefits

- Provides moisture and dust protection for use in harsh industrial environments
- Sealed panel feed-through design for easy installation into enclosures
- 100% optically tested to ensure quality performance assemblies
- Available in single mode and multimode styles to work with any common fiber type
- Housing is NEMA 6P and IP67 rated which ensures dust and moisture protection
- Push-pull insertion with bayonet-style mechanical latch provides easy installation and removal
- Broad temperature range (-40 to +85°C) is ideal for indoor or outdoor applications

APPLICATIONS

Markets and Applications

- Industrial
 - System controls
 - Monitoring
 - High Electro Magnetic Interference (EMI) and Radio Frequency Interference (RFI) areas
- Medical equipment
- Telecommunication/CATV
 - FTTx
 - Outdoor system connections
- Other markets
 - Rugged test equipment
 - Mobile broadcasting or audio visual equipment
 - Food processing



Ball Park – outdoor system connections

SPECIFICATIONS



Optical Industrial Cable Assemblies and Adapters

106059 LC Duplex
106059 SC Simplex
106059 MPO Multi-fiber

Reference Information

Packaging: Cable Assemblies: Individual bag or spool
 Adapters: Individual bag
 Mates With: Standard LC, SC, or MPO assemblies (respectively)
 Designed In: Inches

Physical

Housing: Polymer
 Ferrule: Zirconia Ceramic
 Operating Temperature: -40 to +85° C
 Cable Type: Indoor or outdoor
 Fiber Type: Single mode or multimode

Optical

Insertion Loss:
 Single mode <0.35dB max. (0.13dB typical)
 Multimode <0.50dB max. (0.10dB typical)
 Return Loss:
 Single mode 45 to 55dB
 Wavelength:
 Single mode 1310 or 1550nm
 Multimode 850 or 1300nm



Indoor and Outdoor Industrial LC Assemblies with Industrial LC Adapters

ORDERING INFORMATION

Cable Assemblies

Order No.	Connector Type	Cable	Fiber Count	Fiber Type	
106059-0100	Industrial LC	Indoor	2	Multimode	
106059-0110				Single mode	
106059-1100		Outdoor		Multimode	
106059-1110				Single mode	
106059-2020	Industrial SC		1	Multimode	
106059-2025				Single mode	
106059-6100	Industrial MPO	Outdoor	4	Multimode	
106059-6105					8
106059-6110					12
106059-6115		Single Mode	4		
106059-6120			8		
106059-6125			12		

Note: 1. Optical industrial assemblies are supplied in a cable assembly form only
 2. Above part numbers are for reference drawings only, all assemblies will be assigned custom part numbers

Cable Assembly Accessory

Order Number	Description
106059-0020	Dust Cap/Pulling cap

Adapters

Order No.	Alignment Sleeve	Type	Mode
106059-0200	Phosphor Bronze	Industrial LC to Duplex LC	Multimode
106059-0210	Zirconia		Single mode
106059-3110	Phosphor Bronze	Industrial LC to Industrial LC (in-line)	Multimode
106059-3100	Zirconia		Single mode
106059-2030	Phosphor Bronze	Industrial SC to Simplex SC	Multimode
106059-2031	Zirconia		Single mode
106059-4100	Phosphor Bronze	Industrial SC to Industrial SC (in-line)	Multimode
106059-4110	Zirconia		Single mode
106059-6200	None	Industrial MPO to MPO/MTP	Single mode/Multimode



Indoor industrial LC Assemblies with In-line Industrial LC Adapter



Outdoor Industrial SC Assembly with Industrial SC Adapter and SC Cable Assembly



Outdoor Industrial MPO Assembly with Industrial MPO Adapter and MPO Cable Assembly



Optical Industrial Cable Assemblies and Adapters

106059 LC Duplex

106059 SC Simplex

106059 MPO Multi-fiber

Industrial LC with Outside Plant Cable

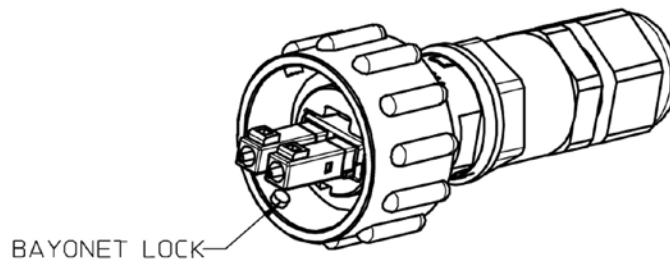
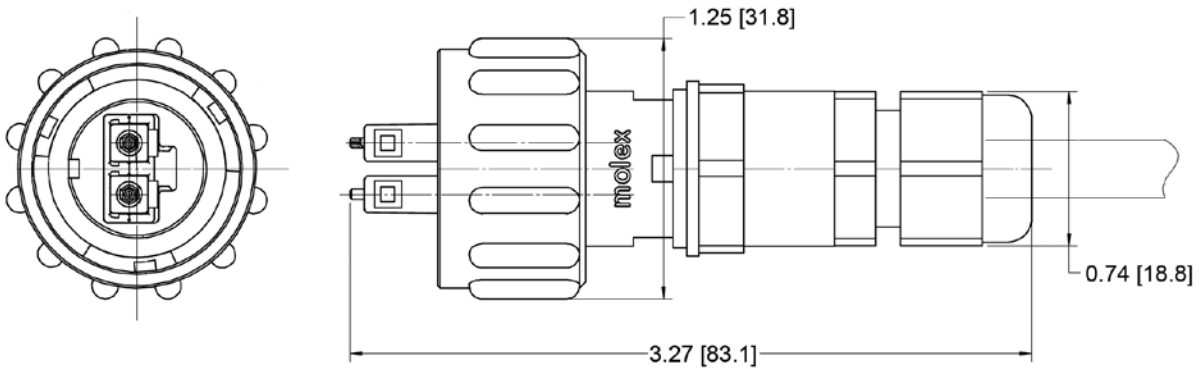

Industrial LC with Indoor Cable

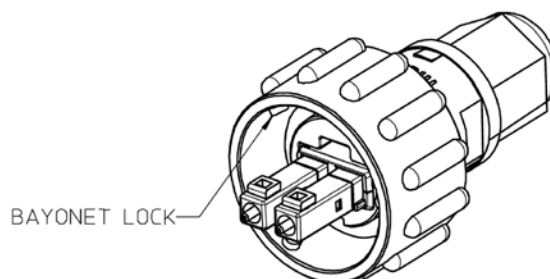
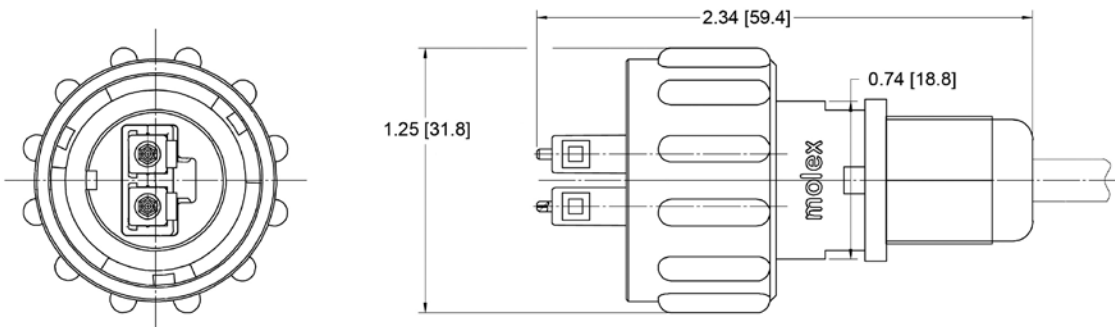

All dimensions are in **INCHES**
(MILLIMETERS)



Optical Industrial Cable Assemblies and Adapters

106059 LC Duplex

106059 SC Simplex

106059 MPO Multi-fiber

Industrial SC with Outdoor Plant Cable

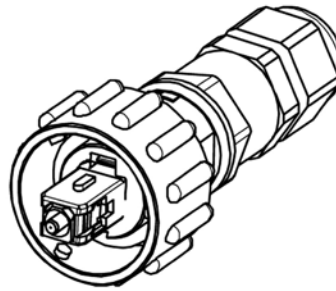
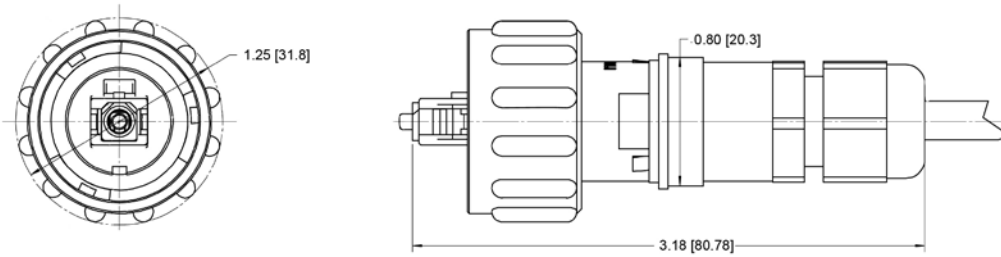

Industrial MPO with Outdoor Cable

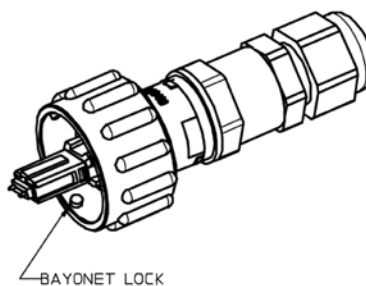
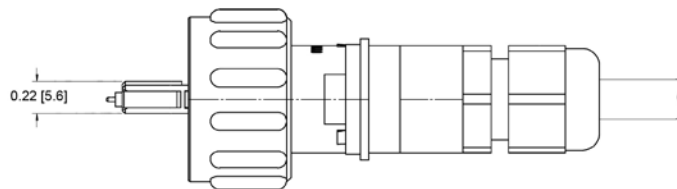
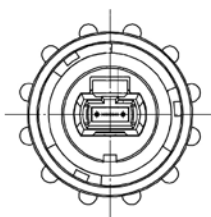
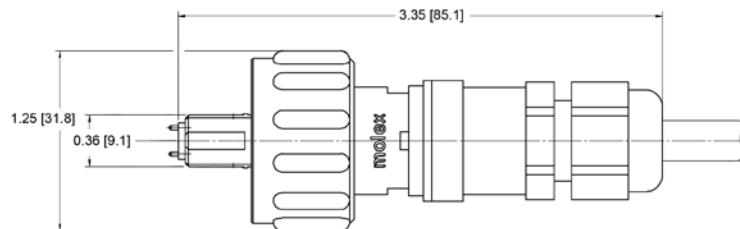

All dimensions are in INCHES
(MILLIMETERS)

ORDERING INFORMATION



**Optical Industrial
Cable Assemblies
and Adapters**

106059 LC Duplex

106059 SC Simplex

106059 MPO Multi-fiber

**Industrial Adapter
with Dust Cap**

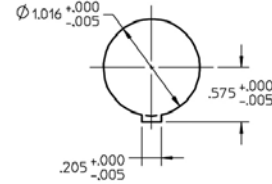
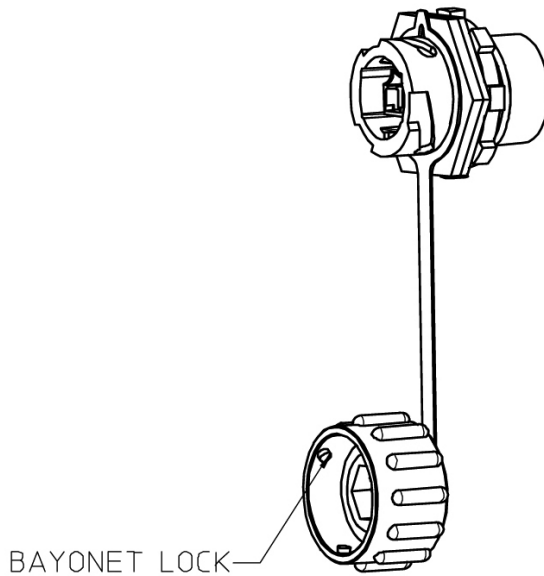

RECOMMENDED MOUNTING CUTOUT

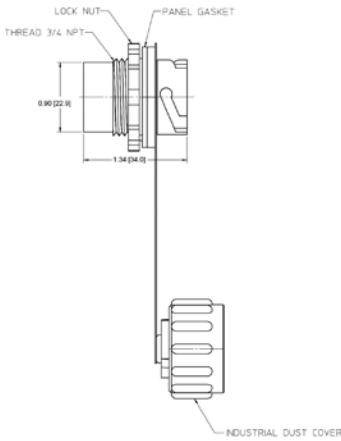

All Styles

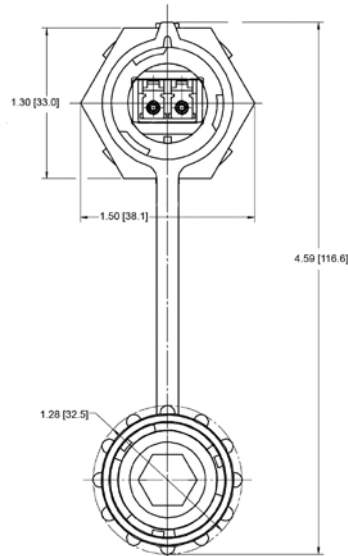

LC
(Duplex)

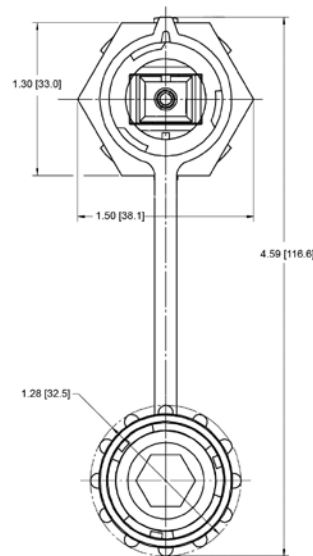

SC
(Simplex)

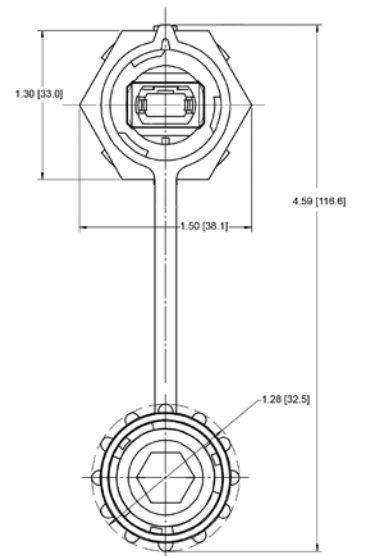

MPO
(8 or 12 fiber)

All dimensions are in **INCHES**
(MILLIMETERS)

ORDERING INFORMATION



**Optical Industrial
Cable Assemblies
and Adapters**

106059 LC Duplex

106059 SC Simplex

106059 MPO Multi-fiber

**Industrial In-Line
Adapter
with Dust Cap**

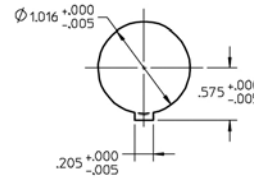
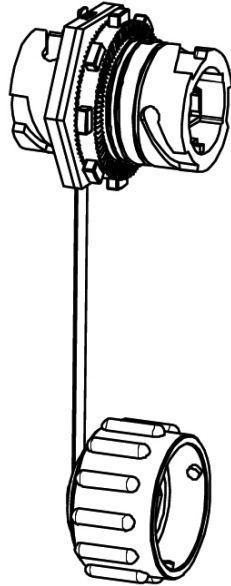

RECOMMENDED MOUNTING CUTOUT

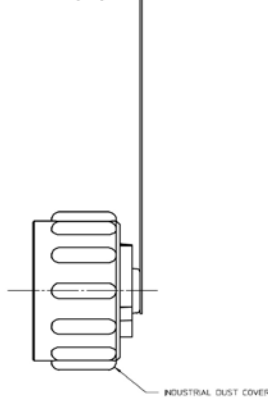
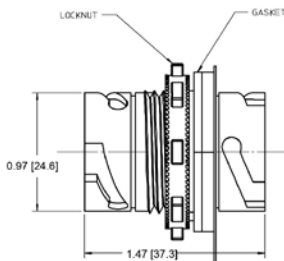

All Styles

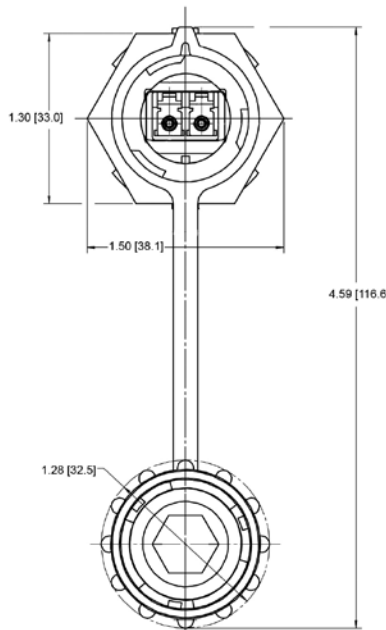

LC
(Duplex)

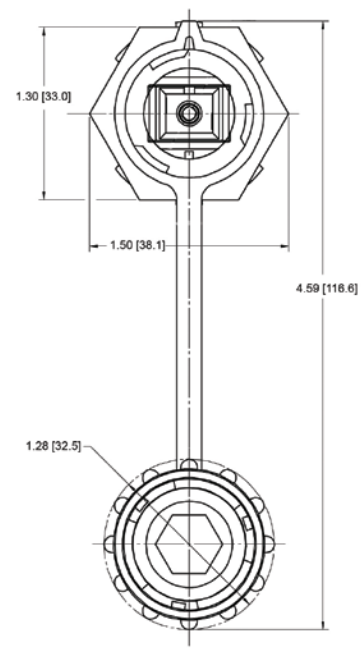

SC
(Simplex)

All dimensions are in INCHES (MILLIMETERS)

Americas Headquarters
Lisle, Illinois 60532 U.S.A.
1-800-78MOLEX
amerinfo@molex.com

Asia Pacific North Headquarters
Yamato, Kanagawa, Japan
81-462-65-2324
feninfo@molex.com

Asia Pacific South Headquarters
Jurong, Singapore
65-6-268-6868
fesinfo@molex.com

European Headquarters
Munich, Germany
49-89-413092-0
eurinfo@molex.com

Corporate Headquarters
2222 Wellington Ct.
Lisle, IL 60532 U.S.A.
630-969-4550
Fax: 630-969-1352

Visit our website at www.molex.com/product/fiber/industrialcables.html

Компания «Life Electronics» занимается поставками электронных компонентов импортного и отечественного производства от производителей и со складов крупных дистрибьюторов Европы, Америки и Азии.

С конца 2013 года компания активно расширяет линейку поставок компонентов по направлению коаксиальный кабель, кварцевые генераторы и конденсаторы (керамические, пленочные, электролитические), за счёт заключения дистрибьюторских договоров

Мы предлагаем:

- Конкурентоспособные цены и скидки постоянным клиентам.
- Специальные условия для постоянных клиентов.
- Подбор аналогов.
- Поставку компонентов в любых объемах, удовлетворяющих вашим потребностям.
- Приемлемые сроки поставки, возможна ускоренная поставка.
- Доставку товара в любую точку России и стран СНГ.
- Комплексную поставку.
- Работу по проектам и поставку образцов.
- Формирование склада под заказчика.
- Сертификаты соответствия на поставляемую продукцию (по желанию клиента).
- Тестирование поставляемой продукции.
- Поставку компонентов, требующих военную и космическую приемку.
- Входной контроль качества.
- Наличие сертификата ISO.

В составе нашей компании организован Конструкторский отдел, призванный помогать разработчикам, и инженерам.

Конструкторский отдел помогает осуществить:

- Регистрацию проекта у производителя компонентов.
- Техническую поддержку проекта.
- Защиту от снятия компонента с производства.
- Оценку стоимости проекта по компонентам.
- Изготовление тестовой платы монтаж и пусконаладочные работы.



Тел: +7 (812) 336 43 04 (многоканальный)

Email: org@lifeelectronics.ru